

User Manual 002444

3.5” K-Punch Tool

Revision 3

September 11, 2020

Revision	Date	Comment	Author	Checked	Approved
1	14 th Feb 2020	First Draft	G Smith	S Christie	P Church
2	19 th March 2020	Revisions showing new Check Valve assembly	G Smith	S Christie	S Christie
3	11th September 2020	Manual revised to reflect existing K-Punch range. Software update revisions added. Assembly drawing 2656 added. All assembly drawings updated.	G Smith	S Christie	S Christie

Table of Contents

1	INTRODUCTION AND SPECIFICATION	4
1.1	OVERVIEW	4
1.2	FEATURES	4
1.3	PHYSICAL PROPERTIES	5
2	OPERATIONAL SAFETY AND WARNINGS	9
3	K-PUNCH DESIGN OVERVIEW AND PRINCIPLE OF OPERATION	11
3.1	2.590" OD K-PUNCH HYDRAULIC ACTUATOR ASSEMBLY	12
3.2	PUNCH HEAD(S)	13
3.3	EXTENSION SUB ASSEMBLY	14
3.4	MAIN PISTON	14
3.5	TUBING NIPPLE	15
3.6	OUTLET SUB	16
3.7	PUNCH HOUSING	17
3.8	PUNCH PISTON SUB-ASSEMBLY	17
3.9	END SUB	18
3.10	RELIEF PISTON SHEAR DISC	19
3.11	A.F.O PLUG	20
3.12	CHECK VALVES	21
4	THEORY OF OPERATION	22
5	K-PUNCH GENERAL ASSEMBLY	25
5.1	HYDRAULIC ACTUATOR GENERAL ASSEMBLY PROCEDURE	25
5.2	PUNCH HEAD GENERAL ASSEMBLY PROCEDURE	38
6	K-PUNCH PRE-DEPLOYMENT CONFIGURATION	41
6.1	FITTING OF PUNCH HEADS AND PHASING	41
6.2	OIL FILL OF K-PUNCH	44
6.2.1	Interfacing the K-Punch to the K-Set	50
6.3	FITTING THE PUNCH BUTTONS	53
6.4	FITMENT OF THE PCM	56
7	PROGRAMMING AND INITIATION OF K-PUNCH COMMANDS	57
7.1	OPERATING THE K-PUNCH IN E-LINE MODE	57

7.1.1	Checking the PCM prior to use	59
7.1.2	Perform Punch Real Time Data Screen.....	60
7.1.3	Performing a Surface Test using the Surface Interface	64
7.1.4	Performing a Reset using the Surface Interface.....	64
7.1.5	Streaming Real Time data to K-Log.....	64
7.2	OPERATING THE K-PUNCH IN SLICKLINE MODE.....	66
7.2.1	Programming in Slickline Mode using the Surface Interface	66
7.2.2	Programming in Slickline Mode using K-Log.....	70
7.2.3	Programming a 'Surface Test' command in K-Log	74
7.2.4	Programming a 'Reset' command in K-Log.....	74
7.3	RETRIEVING DATA FROM THE PCM.....	74
8	DEPLOYMENT OF K-PUNCH	77
9	PERIODIC AND ROUTINE SERVICE INSTRUCTIONS OF K-PUNCH	79
9.1	POST RUN MAINTENANCE OF THE K-PUNCH	79
9.2	SHEAR DISC REMOVAL POST RUN	80
9.3	SPRING PIN FRAGMENT REMOVAL POST RUN	82
10	FIELD USER GOLDEN RULES	85
11	REFERENCE DRAWINGS.....	86
11.1	ASSEMBLY DRAWING 002325	86
11.2	ASSEMBLY DRAWING 002326	87
11.3	ASSEMBLY DRAWING 002656	88
11.4	ASSEMBLY DRAWING 002868	89
12	APPENDIX A - DEFINITIONS, ACRONYMS, ABBREVIATIONS AND REFERENCES.....	90

1 Introduction and Specification

1.1 Overview

The **kaseum K-Punch** range is a retrofittable hydraulic assembly that is used to quickly and safely punch communication holes through tubing and casing

The **kaseum 3.5" tubing K-Punch** assembly utilises a hydro-mechanical system to safely punch up to a maximum of six 0.375" diameter communication holes. The 3.5" tubing **K-Punch** is retrofitted to the bottom of the 2.125" or 2.75" **K-Set** setting tool, and uses its linear stroke to energise the hydraulic system. The 3.5" tubing **K-Punch** does not require jarring or explosives to operate, and will effectively penetrate through the tubing with a simple electronic command. The 3.5" tubing **K-Punch** consists of a 2.590" OD Hydraulic Actuator section that can be configured with one, or multiple Punch Heads depending on the number of communication holes required, up to a maximum of 6.

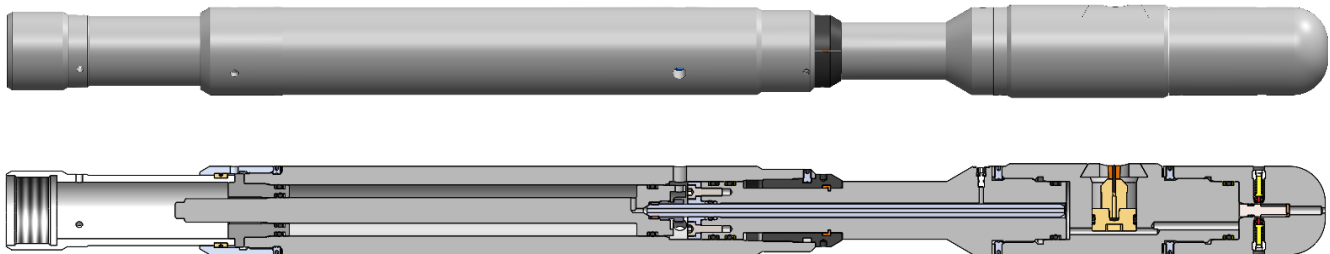



Figure 1 - View of K-Punch



1.2 Features

- **Electronic control:** The **K-Punch** is initiated and controlled electronically for increased accuracy.
- **Modular design:** Allowing multiple Punch Heads for various string configurations.
- **Punch Phasing ability:** Multiple Punch Heads can be rotationally phased to suit operational requirements.
- **Non-explosive:** A hydraulic system eliminates the need for explosives, reducing the safety hazard and logistical challenges involved in the deployment of explosives.
- **Built in safety systems:** The **K-Punch** is designed with multiple safety mechanisms to protect the tool and user from the dangers associated with pressurised systems.
- **Emergency disconnect:** In the unlikely event of a tool failure mid-operation and the tool string is stuck downhole, then the hydraulic chamber can be mechanically vented by jarring to allow the tool string to be recovered.

1.3 Physical Properties

Table 1 - Physical properties of the 3.5” tubing K-Punch and single Punch Head

Maximum OD	<p>When using Punch Head PN 2326 - 2.740” (69.6mm)</p> <p>When using Punch Head PN 2656 - 2.590” (65.8mm)</p>
Overall Length	39.2” (996.4mm)
Make Up length	39.2” (996.4mm)
Tool Weight	<p>When using Punch Head PN 2326 – 46.25lb (20.98kg)</p> <p>When using Punch Head PN 2656 – 45.37lb (20.58kg)</p>
Maximum Operating Pressure (Hydrostatic)	15,000psi (1034 bar)
Maximum Internal Hydraulic Pressure Rating (hydraulic system rating when constrained in the correct grade of tubing)	30,000psi (2068 bar)
Maximum Internal Hydraulic Pressure Rating (hydraulic system rating when un-constrained)	<p>15,000psi (1034 bar)</p>  <p>The Punch Pistons are designed to operate in specific size and weight of API Tubing. If the K-Punch is operated in an un-constrained condition (e.g. it is not run in the correct size of tubing), then the tool is de-rated to 15,000psi. If operated in an un-constrained condition above this rating the K-Punch has enough force to damage the retaining plate on the punch head.</p>
Nominal Relief Shear Disc Rupture Value	22,000psi (1516 bar)
Compatible Tubing Sizes	3.5” (89mm) OD
Compatible Tubing Weights	<p>When using Punch Head PN 2326 - 7.7lb.ft to 10.2 lb. ft</p> <p>When using Punch Head PN 2656 – 12.7lb.ft</p>
Compatible Tubing Materials	J55, L80, P110
Compatible Punch Buttons	<p>3/8” Punch Button (kaseum part number 001387)</p>  <p>Fitting Punch Buttons that are not compatible will cause operational failures.</p>

Minimum Operating Temperature	14°F (-10°C)  The PCM in the K-Set will not perform at full capacity (~50%) when at this temperature. It is advised to keep the PCM at room temperature for as long as possible prior to operation.
Maximum Operating Temperature	275°F (135°C) for 6 hours 250°F (121°C) for 8 hours  Exposure to temperatures greater or longer than stated WILL cause battery leakage, and may damage internal components
Maximum Tensile Rating	E-Line: 25,000lb (11.34 Tonne) at GO Box thread on K-Set PCM Housing Slickline: 30,000lb (13.61 Tonne) at Sucker Rod thread on K-Set PCM Housing
Emergency Shear Ring Disconnect Value	20,000lbs
Minimum Hydrostatic pressure to be deployed within (to push the Punch Pistons in during retract phase)	200psi
Maximum Number of Punch Heads per operation	6* See warnings below



Due to the available hydraulic volume the maximum number of Punch Heads that can be deployed in a single trip is **6**. Fitting of greater than **6 Punch Heads will result in operation failure**.



kaseum recommends the Punch Heads be aligned (0° phased) or equispaced (360 divided by number of Punch Heads for recommended phasing). For example, two punches should be aligned or at 180-degree phasing (2 punches at 90 degrees can lead to instability in the punch operation and is not recommended) see

Table 2 - Recommended phasing angle of this manual for guidance

Table 2 - Recommended phasing angle

Number of Heads	Recommended phasing angle
1	N/A
2	0° or 180°
3	0° or 120°
4	0° or 90°
5	0° or 72°
6	0° or 60°

**Table 3 - Physical properties of 2.74” OD Punch Head f/ 7.7 lb.ft and 10.2 lb.ft tubing.
(kaseum part number 2326)**

Maximum OD	2.74” (69.6mm)
Overall Length	7.3” (186mm)
Make Up length	5.0” (128mm)
Tool Weight	7.78lb (3.53kg)

**Table 4 - Physical properties of the 2.59” OD Punch Head f/ 12.7lb.ft tubing.
(kaseum part number 2656)**

Maximum OD	2.59” (65.8mm)
Overall Length	7.3” (186mm)
Make Up length	5.0” (128mm)
Tool Weight	7.01lb (3.18kg)

2 Operational Safety and Warnings



Pressure failure. The **K-Punch** is designed to be run within a specific size and grade of tubing as outlined in the specification of section 1.3 *Physical Properties* of this manual. If the **K-Punch** is used in tubing out-with this specification, or mechanically unconstrained (i.e. functioning the **K-Punch** without it contacting a solid surface) then the Punch Head Retainer Plate **will yield**, venting the tool hydraulics and cause a catastrophic failure of the Punch Head.

The K-Punch should only be functioned within the correct size of tubing.

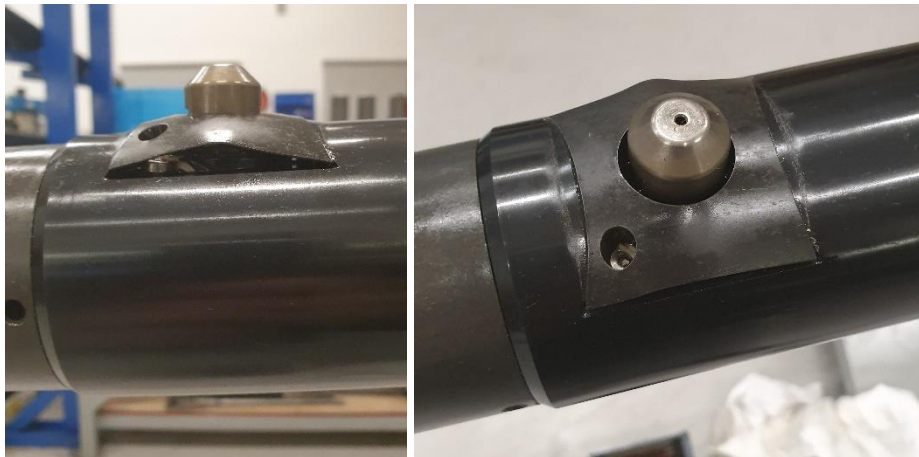

Figure 2 - Pictures showing damaged caused during unconstrained punching operation



Pressurised chamber. The **K-Punch** has an internal hydraulic chamber capable of generating very high pressures. Precautions should be made to ensure that this pressure is managed, and that safety precautions are taken when breaking out any connection that may contain trapped pressure.

Projectile hazard. If the **K-Punch** is to be used or tested on surface then a projectile hazard will be present. When punching, the Punch Button along with the yielded section of tubing will be ejected with a high velocity and force. Also, when the Relief Shear Disc yields during the punching cycle a small volume of very high-pressure oil will be ejected from the End Sub. Ensure adequate barriers are in place to protect all personnel from these associated hazards.



Only Punch when stationary. Once the Punch command has been initiated the running string must remain stationary. Any movement on the running string during the punching cycle may cause the Punch Buttons to be dislodged, resulting in an operational failure.



Thermal expansion of oil. When operated in a hot environment the oil within the **K-Punch** will experience thermal expansion. If a thermal expansion gap is not allowed for then it may cause the Punch Buttons to extend outward prematurely and become dislodged. It is critical that the oil fill procedure is followed. Follow the instruction in section 6.2 *Oil Fill of K-Punch* of this manual for guidance.



Manual Handling. **K-Punch** presents a manual handling risk for a single user due to its size and weight. Use mechanical aids whenever possible or seek assistance from additional personnel in the movement and manoeuvring of the **K-Punch**.



Handling Risks. The **K-Punch** is round and will roll on a flat surface, ensure that the **K-Punch** is stable and secure when placed on flat surfaces.



Handling Risks. When the **K-Punch** is retrieved after deployment it may have handling dangers present (i.e. it can be hot and may present marking/abrasive surfaces due to the nature of the environment it is used in.) Always wear gloves when handling the **K-Punch** as a minimum, and adhere to any local or company handling policies.



Pinch Points. Due to the nature of operation pinch points may exist at the lower end of the tool. The user must take all precautions necessary to ensure that pinch points are identified and that the tool is always functioned in a safe environment where there is no risk of the pinch point causing a safety hazard.



Maximum Running Speed. The maximum recommended running speed for the **K-Punch** is 150ft/min or 50m/min. Running the tool faster than this may cause unnecessary damage or shock to the tool.



Tensile Rating. The maximum tensile rating of the **K-Set** is 25,000lb at the GO Box Thread if using PCM Housing E-Line, or 30 000lbs at Sucker Rod Pin Thread if using the PCM Housing Slickline.



If in doubt about the operation, function or use of the 3.5" tubing K-Punch then STOP and seek assistance.



This manual will describe the function of 3.5" tubing K-Punch ONLY. The user should be familiar with the function of the 2.125" K-Set (kaseum User Manual part number 001878) and these two manuals should be used in conjunction with each other to safety deploy the 3.5" tubing K-Punch.

3 K-Punch Design Overview and Principle of Operation

The 3.5" tubing **K-Punch** assembly is connected to a 2.125" (or 2.75") **K-Set** setting tool prior to deployment to make up the running string. The Slick Rod of the **K-Set** is directly connected to the Main Piston of the **K-Punch**, meaning that any movement generated by the **K-Set** will be transmitted directly to the Main Piston of the **K-Punch**.

The **K-Punch** is a simple hydraulic system that is directly energised or relieved by manipulating the Main Piston upwards or downwards. Once the running string is stationed at the required punching depth the operation can begin. An electronic 'Punch' command is initiated and the **K-Set** will begin stroking upwards, pulling the Main Piston of the **K-Punch**, and pressurising the hydraulic chamber within. As the pressure increases the Punch Piston(s) are forced outwards and the connected Punch Button(s) will contact the wall of the tubing. The hydraulic chamber pressure will continue to rise until a sufficient pressure, and therefore force, has been generated to penetrate the Punch Button through the tubing wall, where the Punch Button will be ejected, leaving behind a communication port to the annular space. Once all Punch Buttons have penetrated, the **K-Punch** will vent the hydraulic chamber by means of a Shear Disc rupture event. The **K-Set** is then commanded to 'Retract' and the Punch Piston(s) are retracted into the tool with the aid of external hydrostatic pressure, allowing the running string to be recovered to surface.

This manual will cover the function and operation of the 3.5" tubing **K-Punch** only.

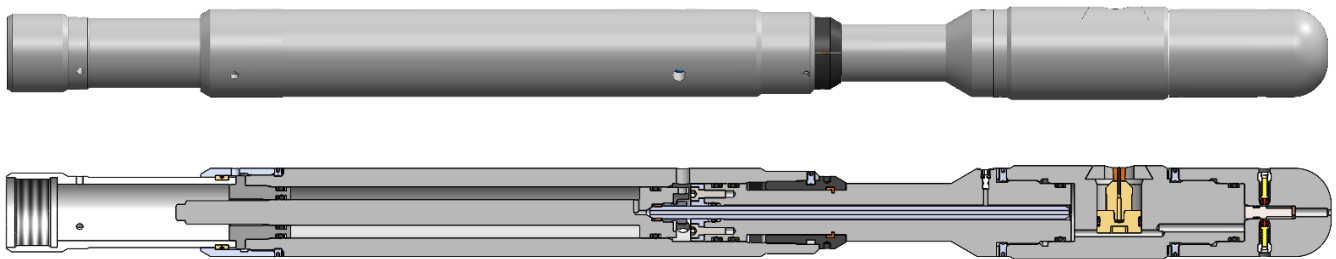

Figure 3 – Cross section view of 3.5" tubing K-Punch with single Punch Head

The 3.5" tubing **K-Punch** consists of 2 separate assemblies. They are:

- 2.590" OD Hydraulic Actuator assembly. (**kaseum** part number 002325)
- Punch Head. either: -
 - 2.740" OD Punch Head(s) (**kaseum** part number 002326) **OR**
 - 2.590" OD Punch Head(s) (**kaseum** part number 002656)

The following is a detailed breakdown of these assemblies:

3.1 2.590" OD K-Punch Hydraulic Actuator assembly

The Hydraulic Actuator assembly is a simple piston operated hydraulic chamber. When the Hydraulic Actuator assembly is interfaced with the **K-Set** the movement generated by the **K-Set** is applied directly to the Main Piston of the **K-Punch**, which will increase or decrease the hydraulic chamber pressure accordingly. A 'Punch' command will cause this hydraulic chamber to reduce in volume, therefore increasing the pressure, which is used to deploy the Punch Pistons. When a 'Retract' command is issued the hydraulic chamber volume is increased causing the pressure to reduce, allowing the Punch Pistons to retract with help from external hydrostatic pressure.

The Hydraulic Actuator also has the mechanical interface, the Extension Sub assembly, to allow the **K-Punch** to be assembled to the **K-Set**. Once hard mounted, the Main Piston of the **K-Punch** screws directly to the **K-Set** Slick Rod, transmitting the linear stroke of the **K-Set** directly to the hydraulic chamber of the **K-Punch**.

The Hydraulic Actuator assembly also has several features that are integral to the correct and safe deployment of the **K-Punch**. They include:

- A Relief Shear Disc; to vent the hydraulic chamber into the external atmosphere after all the Punch Buttons have been deployed, whilst also protecting the hydraulic system from over-pressurisation.
- Check Valves, to allow the hydraulics to be vented at the end of the punching cycle but prevent the ingress of well fluid.
- An Axial Force Only Plug; (hereby referred to as an A.F.O. Plug) to allow the hydraulic chamber to be vented manually, and in a controlled manner, if a risk of internal trapped pressure on return to surface is thought to be present.
- An Emergency Release Shear Ring; to allow the hydraulics to be vented in an emergency situation downhole. In the unlikely event that a complete tool failure occurs during the punching cycle then the running string can be jarred up to release a shear ring that will vent the hydraulic chamber.

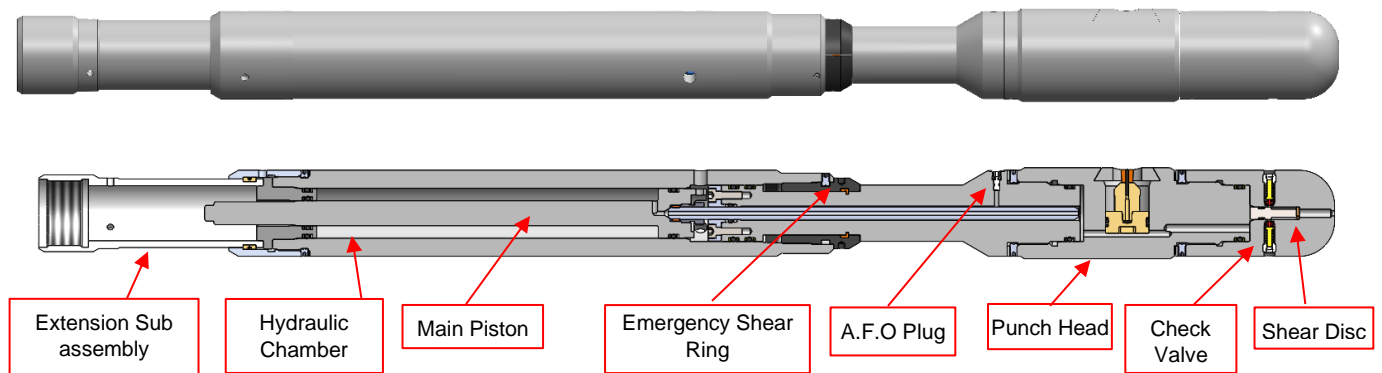

Figure 4 – Hydraulic Actuator assembly images

3.2 Punch Head(s)

The Punch Head contains the Punch Piston sub-assembly used to penetrate the tubing wall. The Punch Head, or Heads, can be fitted onto the Hydraulic Actuator assembly and orientated to the required phasing with the addition of Shim Washers. Each Punch Head has an internal hydraulic chamber that connects into the Hydraulic Actuator assembly hydraulics. Within the Punch Head Housing a Punch Piston sub-assembly that comprise a Punch Piston, Button Holder, Spring Pin and Punch Button is fitted. When the hydraulic chamber is pressurised, this punching arrangement moves out radially to contact the tubing wall. Once sufficient internal pressure, and therefore force, has been reached the Punch Button will penetrate through the tubing and be ejected into the annular space, providing hydraulic communication between the tubing and annulus.

There are 2 variants of Punch Head(s) that can be used depending on the tubing weight. They are: -

- 2.740" OD Punch Head(s) (**kaseum** part number 002326) for use in 7.7lb.ft and 10.2lb.ft
- 2.590" OD Punch Head(s) (**kaseum** part number 002656) for use in 12.7lb.ft



Ensure that the correct Punch Head is used for the correct size and weight of tubing. Using a Punch Head in the wrong size and weight of tubing will lead to operational failures and potential tool damage.

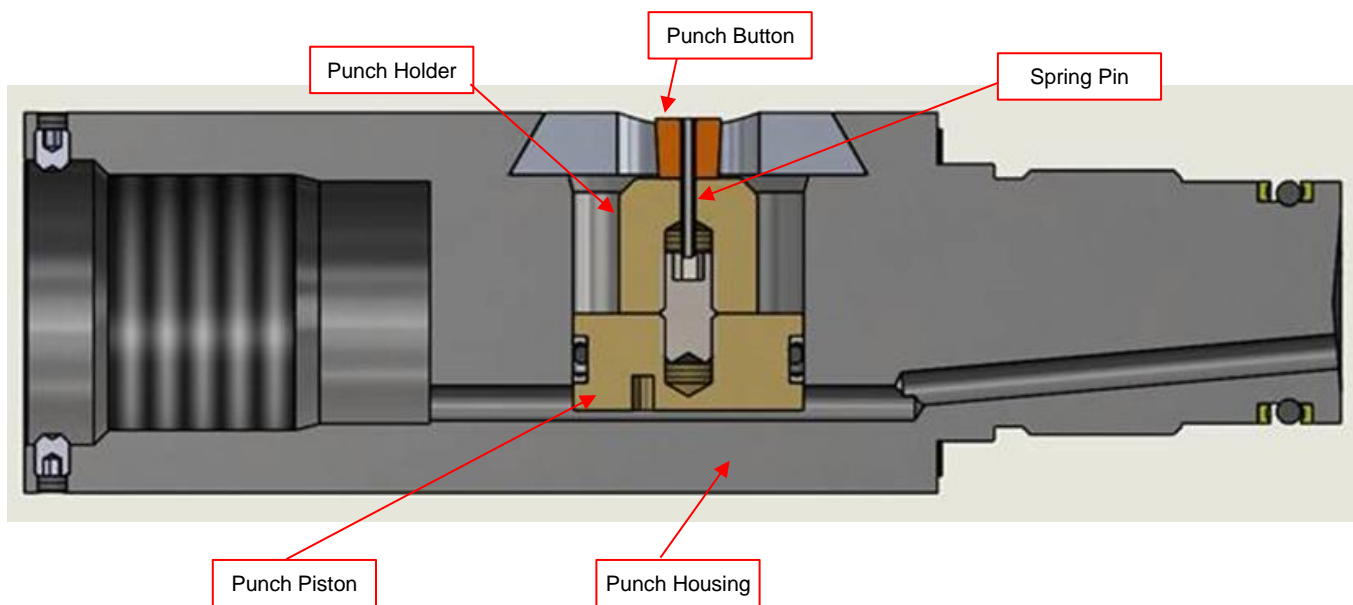

Figure 5 – Punch Head and End Sub image Part Identification and Familiarization

In order to successfully function the **K-Punch**, the user should first familiarize themselves with the tool, specifically the following parts and their function

3.3 Extension Sub assembly

The Extension Sub assembly is used to mechanically connect the **K-Punch** to the **K-Set**. The Extension Sub assembly has a captive free spinning Retainer Cap that facilitates easy make up of this connection.



Figure 6 - Extension Sub image

3.4 Main Piston

The Main Piston is solely responsible for altering the pressure within the hydraulic chamber. The Main Piston is connected directly to the **K-Set** Slick Rod, and upwards movement will cause the hydraulic chamber volume to decrease, therefore increasing the chamber pressure and vice versa.

As with all hydraulic systems sealing integrity is paramount to the correct function of the tool. Therefore, both sealing arrangements on the Main Piston (i.e. the elastomeric O-ring on the Piston and the metal sealing face on the Tubing Nipple) need to be maintained throughout the life cycle of the **K-Punch**.

The Main Piston rod is a dynamic sealing surface; therefore, it is imperative to the correct function of the **K-Punch** that this surface is kept in good condition and is not marked or damaged in any way.



If any damage is present on the dynamic sealing surface then it **must not** be used



Figure 7 - Main Piston image

As mentioned, the Main Piston is connected directly to the **K-Set** Slick Rod. Make-up and break-out of this connection is aided with the addition of a small make up hole on the shoulder of the Main Piston that can be accessed externally through the Piston Housing. Once the make-up hole is aligned with one of the holes in the Piston Housing then a Pin Punch can be inserted to allow the threaded connection to be made up correctly.

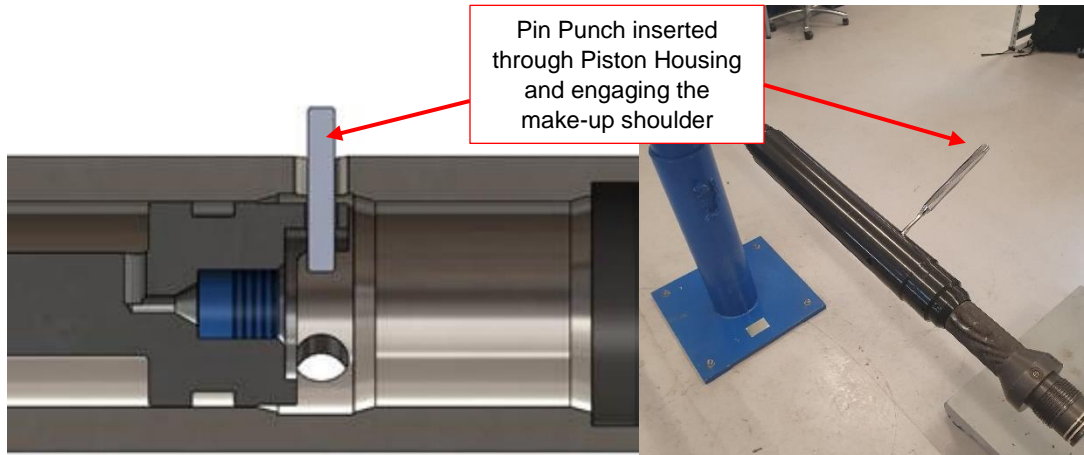

Figure 8 - Image showing make-up of Main Piston to K-Set

3.5 Tubing Nipple

A Tubing Nipple is fitted to the Main Piston to extend the hydraulic chamber into the lower section of the tool. The Tubing Nipple is fitted with a Collar and Nut to mechanically lock the Tubing Nipple to the Main Piston. The Tubing Nipple utilises a metal seal, therefore this Tubing Nut must be made up securely to the Main Piston to ensure hydraulic integrity of the system. It is recommended to check this seal is still intact prior to every operation (**i.e. ensure the Tubing Nut is tight prior to every deployment.**)

Like the Main Piston rod, the Tubing Nipple is also a dynamic sealing surface which must be kept in a good condition and not damaged or marked in anyway.



Figure 9 - Tubing Nipple image



If any damage is present on the dynamic sealing surface of the Tubing Nipple then it **must not** be used

3.6 Outlet Sub

The Outlet Sub is a continuation of the hydraulic chamber that allows Punch Head(s) to be plumbed into the hydraulic system. There are 3 critical parts of the Outlet Sub which are all critical to the successful operation of the tool. they are:

- At the top of the Outlet Sub the elastomeric seal arrangement for the Tubing Nipple is situated internally and requires periodic redress.
- The Emergency Shear Ring mechanism is also mounted on the Outlet Sub. This will allow the hydraulic chamber to be vented in the unlikely event of a stuck tool situation downhole. If the tool is stuck with trapped pressure internally then the tool string can be jarred upwards, shearing the Emergency Shear Ring and allowing the Piston on the Outlet Sub to unseat, venting the hydraulic chamber into the external atmosphere.
- An A.F.O plug is also accessible on the external profile of the Outlet Sub. This allows direct communication into the hydraulic chamber, allowing the hydraulics to be safely vented if trapped pressure is thought to be present at surface.



Figure 10 - Outlet Sub image

3.7 Punch Housing

The Punch Head assembly is made up of a Punch Housing and Punch Piston sub-assembly. The Punch Housing is part of the hydraulic chamber; therefore, all seals should be maintained regularly to ensure hydraulic integrity. The Punch Piston sub-assembly is fitted into the Punch Housing and retained by means of a sliding Retainer Plate. The Punch Head(s) can be oriented to the required phasing by adding Shim Washers as required. The 3.5” tubing K-Punch can be fitted with up to a **maximum of 6 Punch Heads per deployment**.



Figure 11 - Punch Heads

3.8 Punch Piston sub-assembly

The Punch Piston sub-assembly consists of the Punch Piston, Punch Holder, Spring Pin and Punch Button. The Punch Button and Spring Pin are consumable parts and new parts **must be fitted to the Punch Holder prior to each deployment**. The Punch Button has a trapezoidal shape and its orientation during fitting is critical. The Punch Button is to be fitted with the largest face contacting the tubing wall, and the smaller face against the Punch Holder. The Spring Pin should have a slight interference fit with the Punch Holder and Punch Button to ensure it will not fall out during handling or run in hole. After deployment a portion of the Spring Pin may be left in the Punch Holder and this should be removed after each operation.

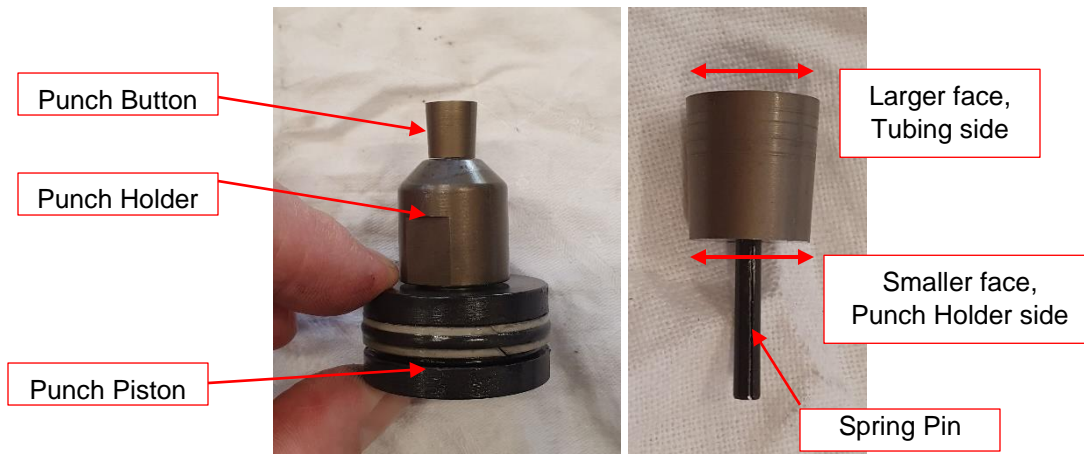

Figure 12 - Punch Piston sub-assembly images



The Punch Button **must be fitted** in the correct orientation. Failure to ensure the correct orientation will result in operational failures.

3.9 End Sub

The End Sub is the lowermost part of the **K-Punch** and houses the Relief Shear Disc and Piston as well as two Check Valve arrangements which should be tested periodically. The End Sub should be removed during the oil fill procedure to allow air to be evacuated easily. It is recommended to fill the End Sub with oil prior to fitting to ensure that no air pockets are introduced during the oil fill process. (this is explained in greater detail in section 6.2 *Oil Fill of K-Punch* of this manual)

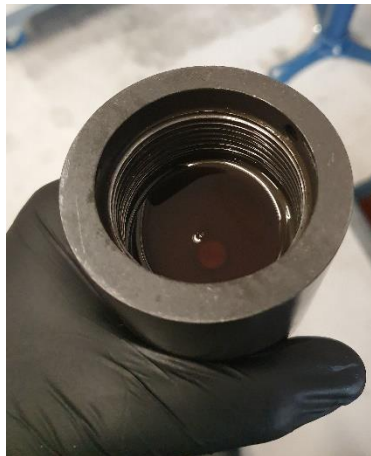

Figure 13 - End Sub filled prior to fitting

3.10 Relief Piston Shear Disc

A Relief Piston and a consumable Relief Shear Disc are used to allow the hydraulic chamber to vent once all the connected Punch Buttons have been deployed. The Relief Shear Disc also ensures that the **K-Punch** hydraulic pressure never exceeds a safe nominal value. The Relief Shear Disc provides mechanical support for the Relief Piston, sealing off the Check Valves. Once the internal hydraulic chamber pressure exceeds the rating of the Relief Shear Disc it will yield and the mechanical support will be lost. The Relief Piston will travel downwards, opening the Check Valves to the hydraulic chamber and allowing the pressure to be vented to the external atmosphere.

After operation there are several remnants of the Relief Shear Disc retained within the End Sub that must be removed.



Failure to remove the old remnants of Relief Shear Disc **will cause** assembly issues for future deployments



Figure 14 - Relief Disc image fitted into End Sub and remnants of the sheared Disc after deployment

3.11 A.F.O Plug

An A.F.O plug is situated on the Outlet Sub and allows direct communication into the hydraulic chamber to allow the user to safely vent the hydraulics if required. The A.F.O Plug has a dual sealing system which consists of a primary metal seal that is seated into the Outlet Sub. The hydraulic integrity of the system is dependent on the A.F.O. Plug being in a good, serviceable condition and ensuring that it is fitted securely prior to each operation.

There is also a secondary elastomeric O-ring seal that allows the A.F.O. Plug primary metal seal to be unseated slightly and allow the internal pressure to vent through an external vent port, without any of the pressure coming out past the A.F.O Plug body.

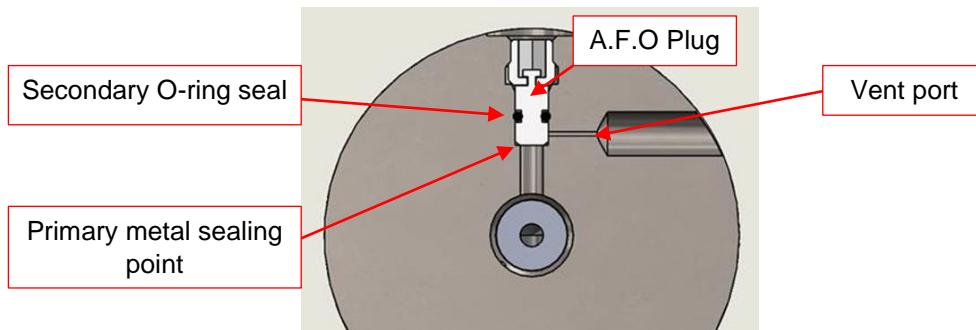

Figure 15 - A.F.O Plug cross section image

The **K-Punch** system is designed to vent all internal pressure if the operation sequence is followed correctly. In the event of a tool failure, or the operational procedure is not followed, there is the possibility that trapped hydraulic pressure may be present inside the tool. A prime indicator of trapped pressure will be that the Punch Pistons are not fully retracted when recovered back to surface, and cannot manually be pushed back below the tool OD. If there is any evidence or concern that the tool has internal hydraulic pressure then the A.F.O Plug should be unseated to vent the hydraulic chamber prior to disassembly of the tool.

The A.F.O Plug, like any other sealing device should be serviced and replaced periodically to ensure the hydraulic integrity of the system.

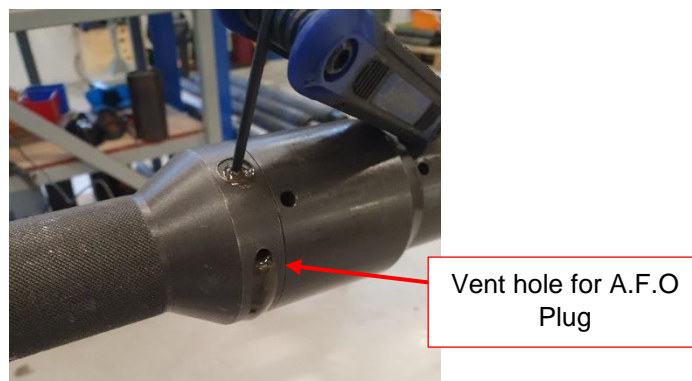

Figure-16 - A.F.O Plug vent image

3.12 Check Valves

Two basic Check Valves are fitted in the End Sub which comprise a Valve held on an elastomeric Seal by a Spring. These allow the hydraulic chamber to be vented to the external atmosphere, whilst stopping any external well fluid from entering the chamber.

During normal operation the Check Valves are not subjected to the pressure exerted by the hydraulic chamber, due to the Relief Piston. Once the Relief Piston is forced downwards after the Relief Shear Disc rupture, these Check Valves are now incorporated in the hydraulic chamber. The Check Valves will unseat, allowing oil to vent into the external atmosphere while the **K-Set** completes its setting cycle, displacing all oil from the hydraulic chamber.

During this resetting phase the Check Valves will seat and prevent well fluid from entering the Punch Hydraulic Chamber. This will reduce the internal hydraulic chamber pressure and with the assistance of the external hydrostatic pressure, allow the Punch Pistons to retract.

The Check Valves must be checked prior to each deployment to ensure they are in serviceable condition.



Failure to maintain the Check Valves will cause the Punch Pistons not to retract after operation, resulting in operational failures.

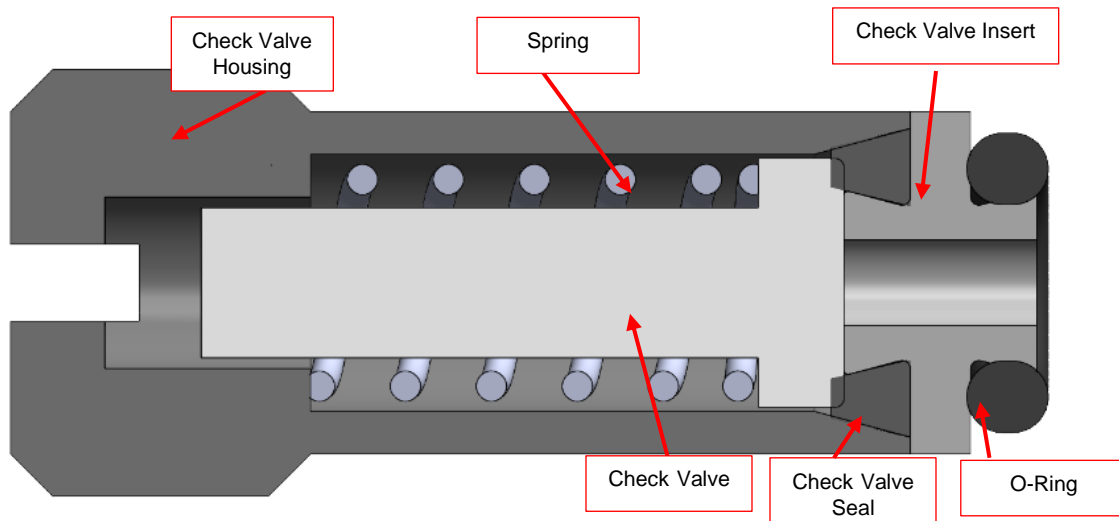

Figure 17 – Check Valve arrangement image

4 Theory of Operation

The **K-Punch** is assembled with the desired amount of Punch Heads and phased in accordance with *Table 2 - Recommended phasing angle* of this manual. Once correctly filled with oil and the Punch Buttons are fitted the **K-Punch** can be interfaced with the **K-Set** to make up the running string.

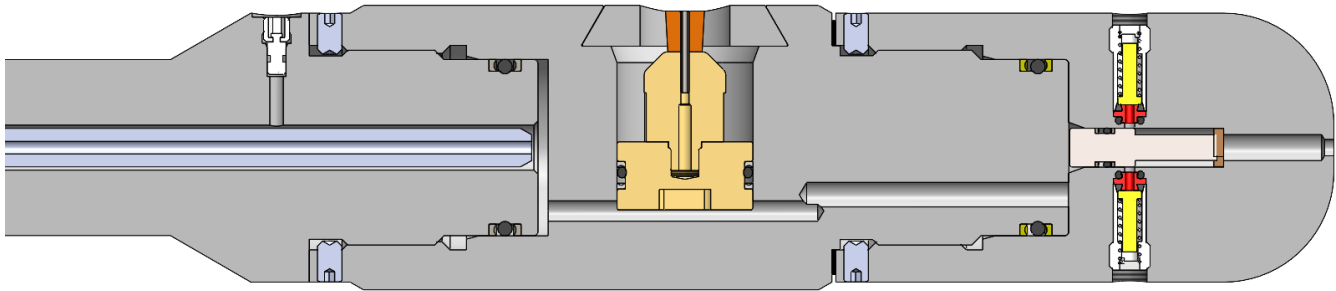

Figure 18 – Single Punch K-Punch in the ‘Ready to Run’ position

The running string is deployed in hole and positioned at the required punching depth. Once a ‘Punch’ command is initiated the punch process begins. The **K-Set** pulls the Main Piston of the **K-Punch** upwards, compressing the hydraulic chamber and increasing the hydraulic pressure. As the pressure rises the Punch Pistons are forced outward until the Punch Buttons contact the tubing wall.

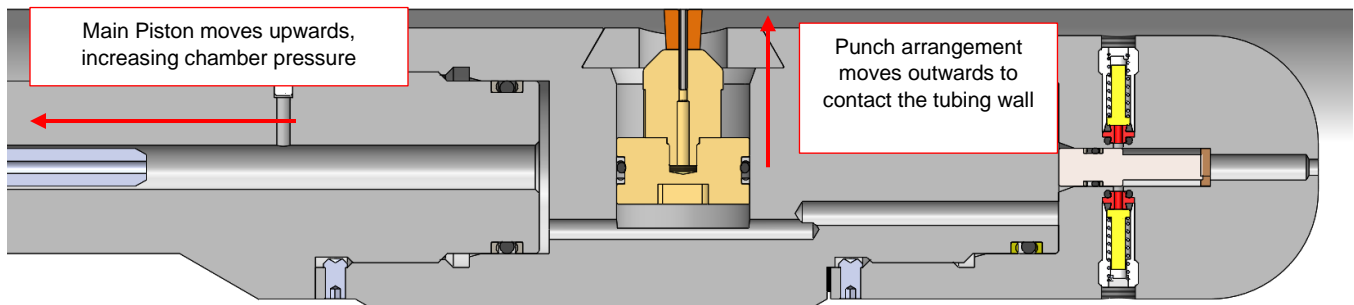

Figure 19 - Punch Button contacting tubing wall

Pressure continues to increase until the tubing yields and the Punch Button is ejected through the tubing wall into the annular space.

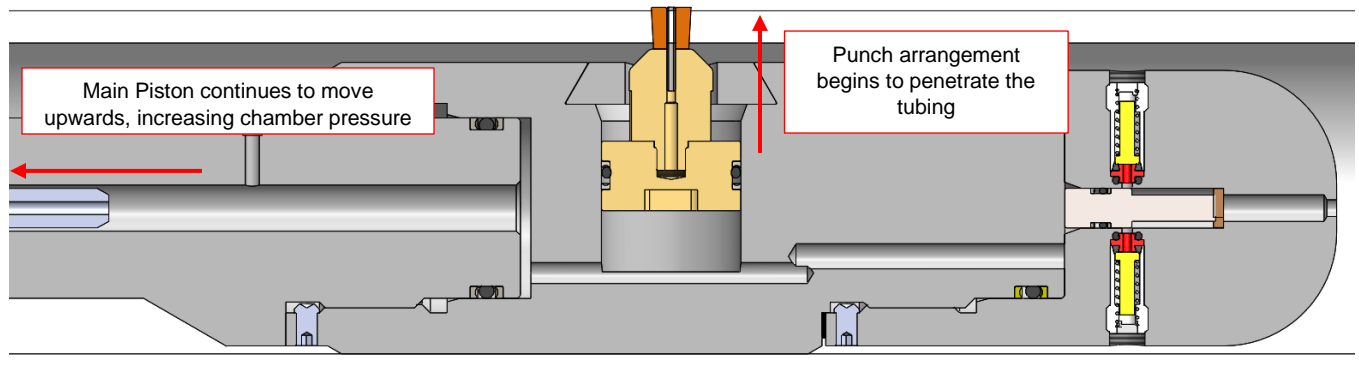

Figure 20 - Punch Button pushing through tubing wall

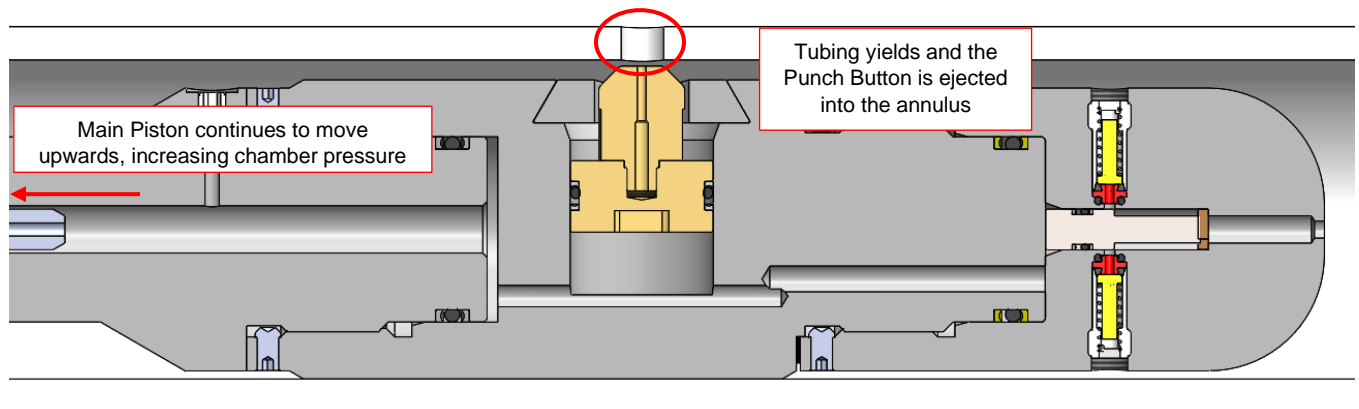

Figure 21 - Tubing yield image

Once all Punch Buttons have been deployed the hydraulic chamber pressure will continue to rise until the Relief Shear Disc yields, forcing the Relief Piston downwards and allowing communication from the hydraulic chamber to the external atmosphere through the Check Valves.

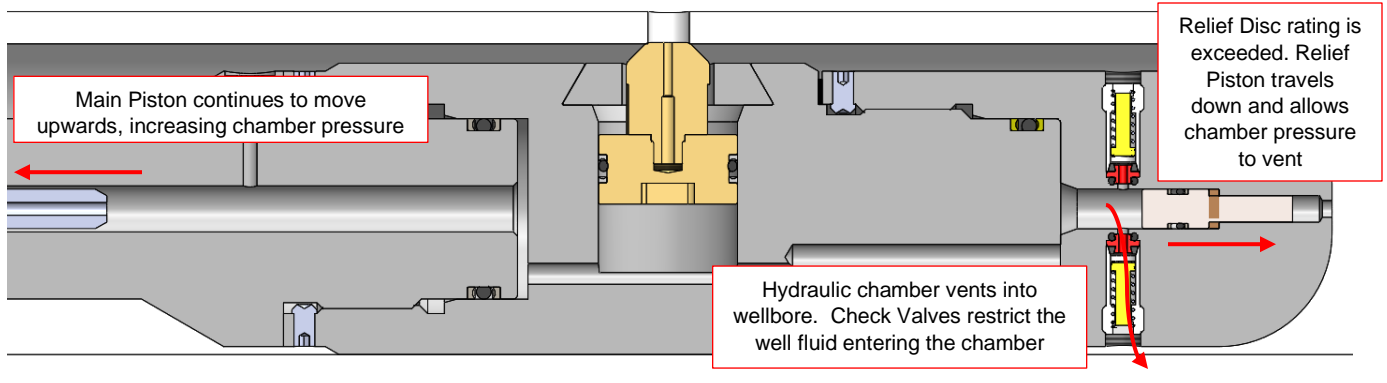

Figure 22 - Relief Shear Disc yield image

The 'Punch' command will continue until the **K-Set** reaches the end of its available stroke where it will power down automatically.

Once the 'Punch' command is completed a 'Retract' command is initiated which will push the Main Piston downwards, increasing the hydraulic chamber volume and therefore lowering the hydraulic chamber pressure. Once at the end of its stroke the tool will power down automatically and the hydraulic chamber pressure will be vented.

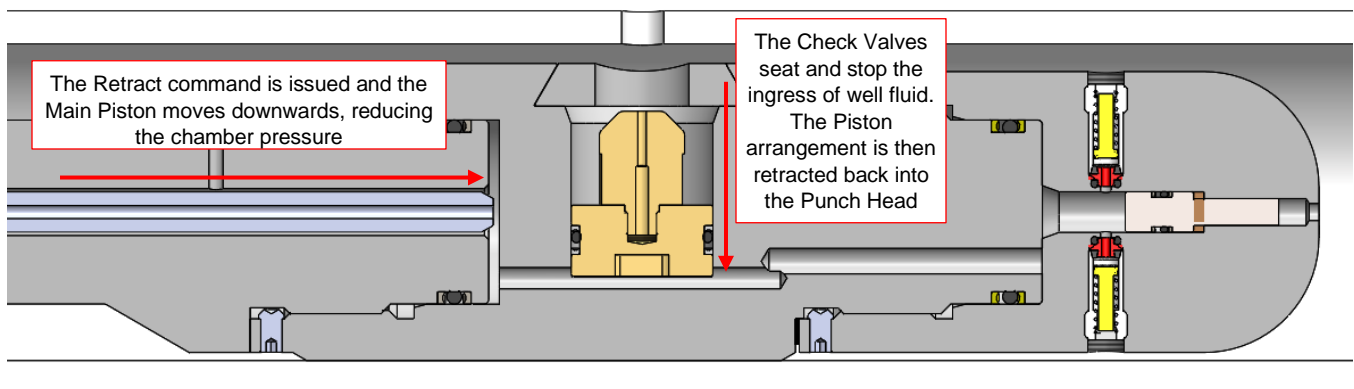

Figure 23 - Retract image

The operation is now complete and the running string can be recovered to surface

5 K-Punch General Assembly

The following section describes the general assembly of the **K-Punch**.

Please refer to the assembly drawings in the reference section of this manual for guidance and part identification.



Prior to general assembly ensure all parts are in good visible condition and all elastomeric seals are new. All sealing surfaces, especially the dynamic sealing surfaces (i.e. The Main Piston rod and Tubing Nipple) must be in good condition and free from any marking or damage. Ensure all elastomers and threads are lubricated with suitable grease prior to assembly.



Prior to deployment the **K-Punch** must be fitted with the desired quantity of phased Punch Heads, filled with hydraulic oil and fitted with Punch Buttons. These operations are described in more detail in section 6 *K-Punch Pre-Deployment Configuration* of this manual.



The **K-Punch** uses directional Back-Up rings. Always ensure the Back-Up ring is orientated and fitted correctly (i.e. concave side of the Back-Up ring should always be facing the O-Ring)



Refer to the latest assembly drawings for guidance and part identification.

5.1 Hydraulic Actuator general assembly procedure

- Fit the A.F.O. Plug securely into the port of the Outlet Sub using an 1/8" Hex Key. The installation torque for the AFO Plug is 55 in.lbs.



Figure 24 - A.F.O Plug image and assembly



The A.F.O Plug is connected directly into the hydraulic chamber. Failure to fit the A.F.O Plug, or tighten it down securely, **will cause operational failure**.

- Fit the O-Rings and Back-up rings, into the upper and lower sealing grooves of the Outlet Sub.



Figure 25 - Outlet Sub image

- In the upper end of the Outlet Sub is the internal dynamic sealing bore for the Tubing Nipple. Before fitment of the O-ring Seal and Back-Up rings, ensure that all previous O-ring seals and Back-Up rings have been removed. Fit the O-ring and Back-up rings.



Figure 26 – Tubing Nipple sealing arrangement location and fitment images

- The End Plate has a small spigot that is used to compress the Tubing Nipple seal arrangement. Orient the End Plate with the spigot facing onto the Tubing Nipple seal arrangement and secure in place with the 4 off Cap Screws using a Hex Key.



Figure 27 – End Plate orientation and installation image

- Fit the Emergency Shear Ring assembly. If the **K-Punch** becomes stuck downhole then the Emergency Shear Ring can be released to allow the **K-Punch** to vent any internal pressure by jarring upwards on the running string.

The Emergency Shear Ring has an L-shaped geometry and must be fitted into the groove of the Outlet Sub in the correct orientation. Fit the Emergency Shear Ring to the groove on the Outlet Sub and retain by fitting the Split Retainer, ensuring all 4 Dowels and Washers are fitted.

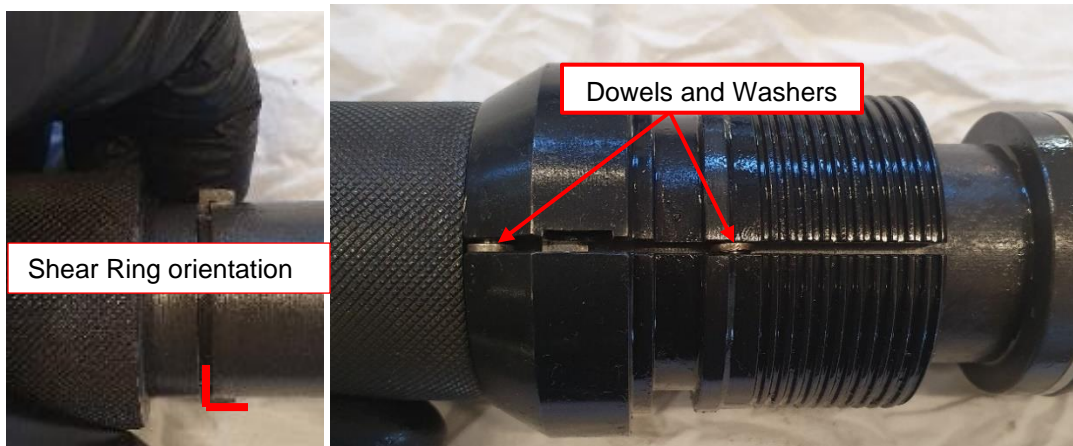

Figure 28 - Emergency Shear Ring orientation image



The Emergency Shear Ring can only be fitted in one orientation. If the Emergency Shear Ring is fitted incorrectly the Split Retainer will not fit on the Outlet Sub.

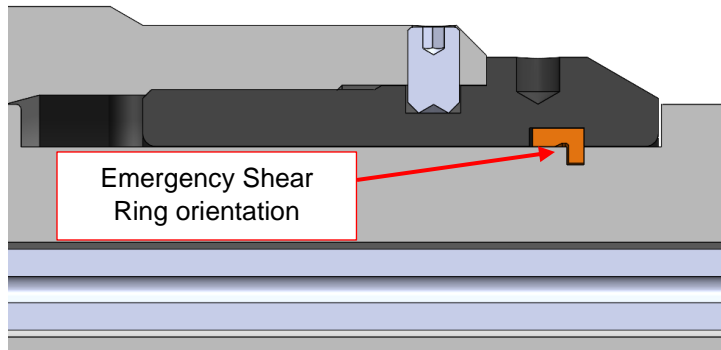

Figure 29 - Image showing Emergency Shear Ring orientation



The Emergency Shear Ring is stamped with the shear value required to release (20 000lbs as standard). Ensure this value is noted for future reference.



In an emergency situation (i.e. the tool string is stuck downhole due to the Punch Pistons being in the outward position and trapped pressure remains in the hydraulic system) the hydraulic chamber can be vented by shearing out the Emergency Shear Ring.



The Emergency Shear Ring can only be released by jarring upwards

- Fit the O-Ring and Back-Ups to the Main Piston.

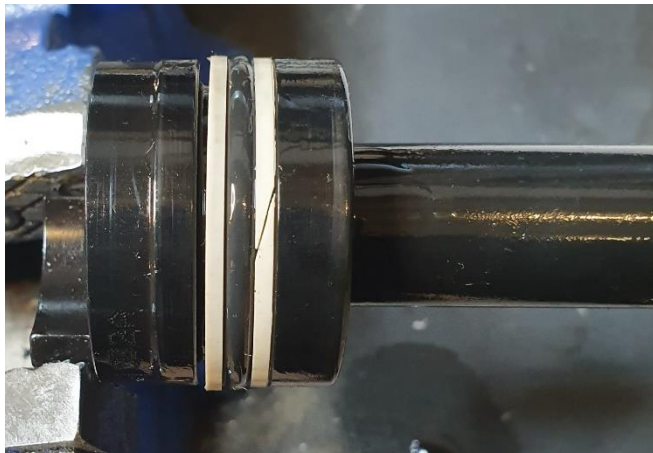

Figure 30 - Main Piston seal arrangement image

- Fit the Tubing Collar and Nut to the Tubing Nipple. Space out the Tubing Collar so the sealing angle is exposed and will mate securely into the opposing sealing face.

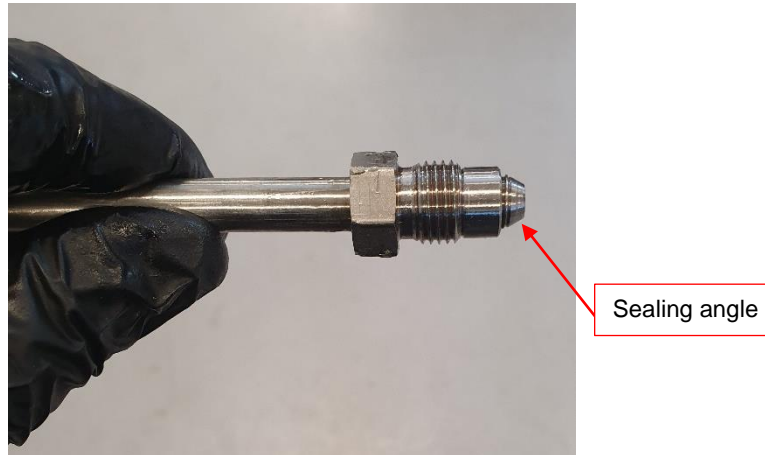

Figure 31 - Tubing Nipple assembly image

- Fit the Tubing Nipple to the Main Piston by securing the Tubing Nut. Once the Tubing Nut is tightened the Tubing Nipple should be rigid. If the Tubing Nipple can rotate then the spacing of the Tubing Collar in relation to the sealing angle is insufficient and not providing a seal. Repeat the above process until the Tubing Nipple is secure and will not rotate.



Caution. The Main Piston and Tubing Nipple have dynamic sealing surfaces and **must not** be damaged. When making up the Tubing Nipple to the Main Piston it is recommended to grip the Main Piston make-up shoulder in a vise and tighten the Tubing Nipple with a 16mm Spanner.



Figure 32 - Make-up of Tubing Nipple to Main Piston

- Slide the Main Piston assembly into the upper end of the Piston Housing.

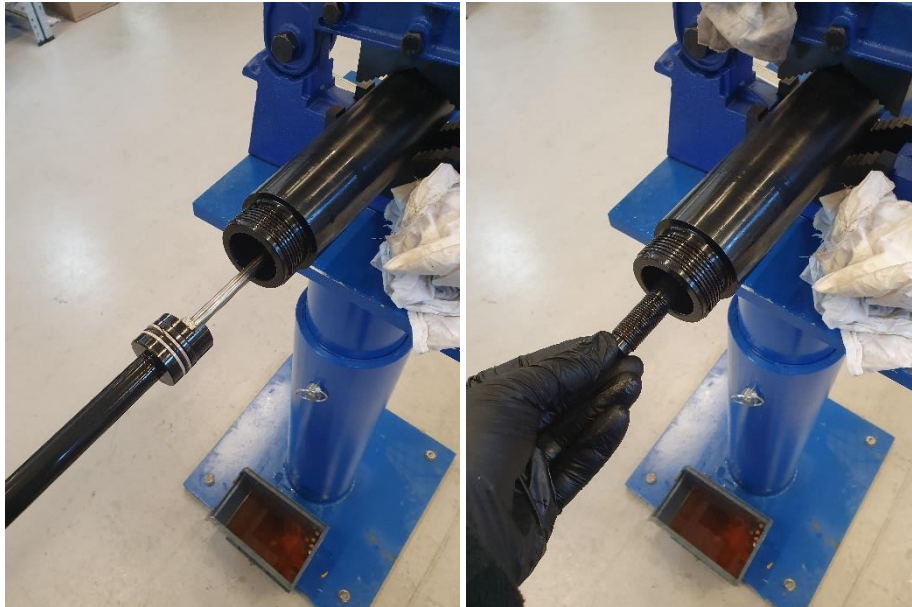

Figure 33 - Main Piston assembly fitment image

- Using a Pin Spanner or similar, slide the Outlet Sub over the Tubing Nipple and tighten the Split Retainer to the Piston Housing.



Figure 34 - Outlet Sub installation

- Fit the O-Rings and Back-Ups rings to the internal and external sealing grooves on the Piston Ring.



Figure 35 - Piston Ring image

- Slide the Piston Ring over the Main Piston rod and fit into the Piston Housing.

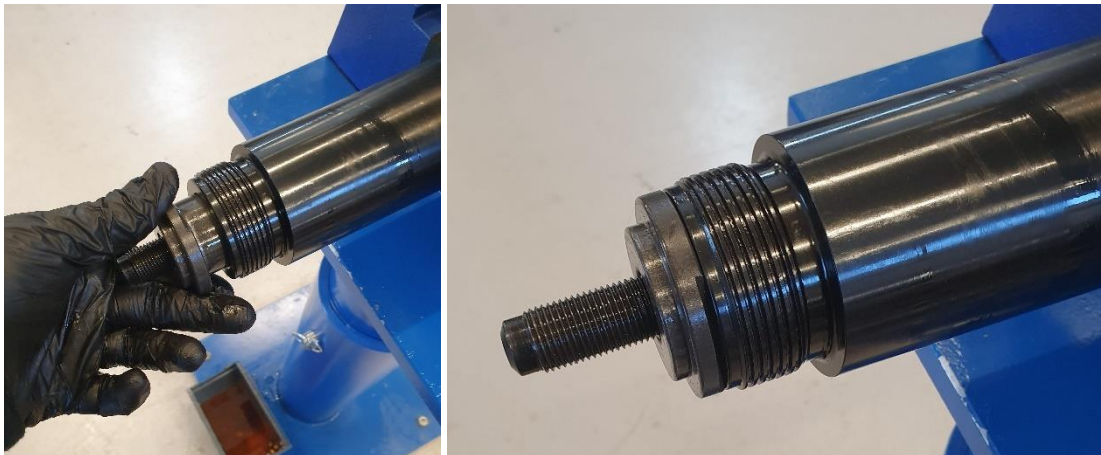

Figure 36 - Piston Ring fitment images

- Slide the Retainer Cap over the Extension Sub ensuring the threaded side of the Retainer Cap is at the lower side. Fit the Split Ring and O-Ring onto the groove of the Extension Sub to retain the Retainer Cap.

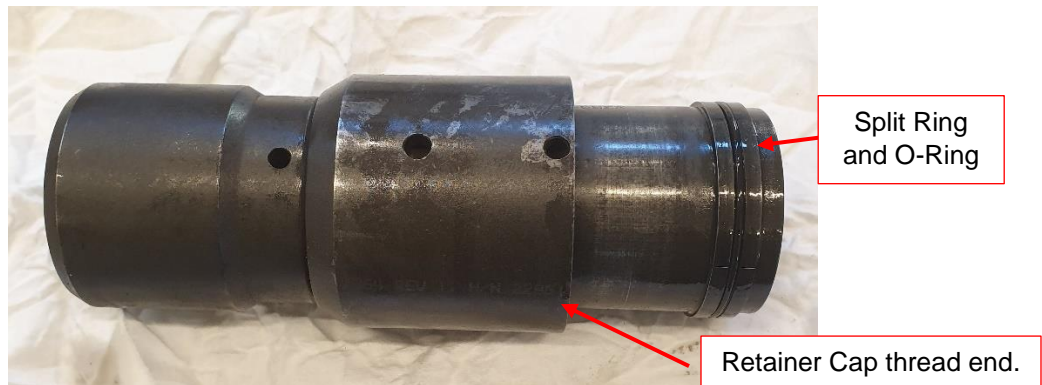

Figure 37 - Extension Sub assembly image

- Fit the Extension Sub assembly onto the Piston Housing.



Figure 38 - Extension Sub assembly fitted to the Piston Housing

- Now the End Sub can be assembled. Fit the Check Valve Seal and O-Ring to the Check Valve Insert.



Figure 39 - Check Valve Seal and O-Ring fitted to Insert

- Carefully place the Insert into the End Sub ensuring the Check Valve Seal is uppermost.



Figure 40 - Check Valve Insert Orientation image

- Place the Check Valve onto the Check Valve Insert ensuring it is seated centrally. Fit the Spring over the Check Valve and screw in the Check Valve Housing to retain.



Figure 41 - Images Showing Check Valve, Spring and Check Valve Housing Fitment

- Repeat the above steps and fit the second Check Valve assembly to the End Sub.



Figure 42 - Image showing Check Valve assembly fitted

- Fit the O-Ring and Back Up Rings onto the Relief Piston.



Figure 43 - Relief Piston seal arrangement image

- Fit the Relief Piston into the Port of the End Sub ensuring the seal arrangement is uppermost. Using a Pin Punch or similar insert the Relief Piston until it shoulders out on the bottom of the inner port.

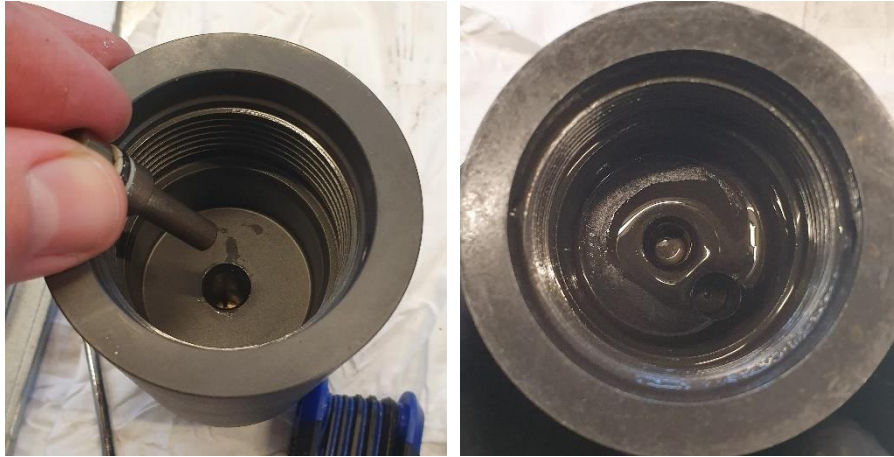

Figure 44 - Relief Valve fitted into End Sub

- Fill the End Sub with a small volume of fluid and perform a leak test on the Check Valves. This can be done by applying air pressure into the top of the Check Valve Housing, ensuring that the air does not enter the End Sub internal port (i.e. no bubbles should be visible in the fluid).



Figure 45 - Check Valve leak test images

- If both Check Valves pass the leak test drain the fluid and remove the Relief Piston. Use a Pin Punch or similar through the access hole in the End Sub to aid in removal. Ensure the O-ring on the Relief Piston is still in good condition after removal.



Figure 46 - Access hole to remove Relief Piston image

- Fit the Relief Shear Disc into the internal port of the End Sub, ensuring it is fully seated.



Failure to correctly fit the Relief Shear Disc **will** result in operational failure



Figure 47 - Relief Shear Disc image

- Fit the Relief Piston into the Port of the End Sub ensuring the seal arrangement is uppermost. Once fitted ensure the end face of the Relief Piston sits below flush with the inner face of the End Sub.



Figure 48 - Relief Piston fitment images

- Fit the End Sub to the Outlet Sub. Fit the Bull Nose to the End Sub.



Figure 49 - End Sub and Bull Nose fitment image

5.2 Punch Head general assembly procedure

- Fit the O-Ring and Back-Up Rings to the Punch Housing.



Figure 50 - Seal arrangement fitted to Punch Housing image

- Fit the O-Ring and Back-Up Rings to the Punch Piston. Apply Loctite 272 (or similar medium/high strength thread lock) to the Set Screw and fit to the Punch Piston using a Hex Key. Once these items are thread locked together, they do not need to be split apart during subsequent run redress.



Figure 51 - Set Screw fitted to Punch Piston

- Fit the Punch Holder to the Punch Piston and tighten securely using a large Screwdriver in the lower slot of the Punch Piston and an open-ended Spanner on the flats of the Punch Holder.



Figure 52 - Fitting of Punch Holder to Punch Piston image

- Fit the Punch Piston assembly into the port of the Punch Housing until it bottoms out.



Figure 53 - Punch Piston installation image

- Slide the Retainer Plate in position and secure in place with the Cap Screw using a Hex Key



Figure 54 - Retainer Plate installation image

6 K-Punch Pre-Deployment Configuration

Prior to deployment of the **K-Punch** the user must ensure the following processes are carried out:

1. General assembly of the Hydraulic Actuator assembly and Punch Head(s), ensuring correct phasing if using more than one Punch Head.
2. Filling the **K-Punch** with hydraulic oil, ensuring any air in the hydraulic chamber has been evacuated and a 2" (51mm) thermal expansion gap has been allowed for.
3. Interfacing the **K-Punch** to the **K-Set**.
4. Fitment of the Punch Buttons
5. Fitting of the correct PCM.

6.1 Fitting of Punch Heads and phasing

The Punch Heads can be positioned to the required phasing by adding Shim Washers in-between each Punch Head.

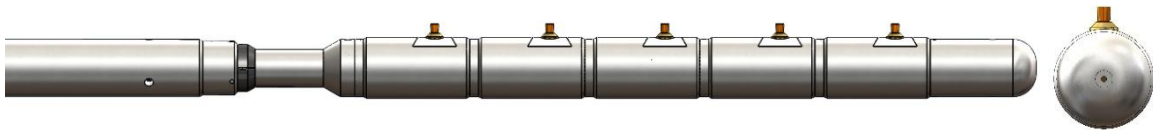

Figure 55 - Image showing 5 Punch Heads phased at 0°

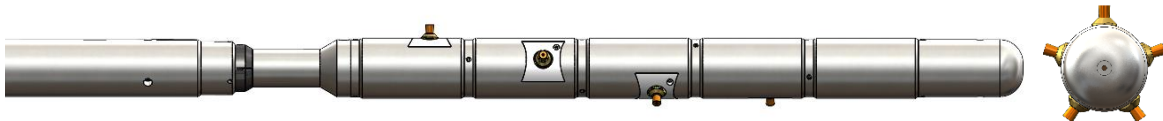

Figure 56 - Image showing 5 Punch Heads phased at 72°



Due to the available hydraulic volume only **6 Punch Heads** can be used in a single trip. Fitting of greater than **6 Punch Heads will result in operation failure**.



kaseum recommends the Punch Heads be aligned (0° phased) or equispaced (refer to *Table 2 - Recommended phasing angle* of this manual for guidance).

1. Build the Hydraulic Actuator assembly as per the procedure mentioned in section 5.1 *Hydraulic Actuator general assembly procedure* of this manual.
2. Build the Punch Head(s) as per the procedure mentioned in section 5.2 *Punch Head general assembly procedure* of this manual.
3. Remove the End Sub and fit the first Punch Head securely to the Hydraulic Actuator assembly.



Figure 57 - Punch Head fitted to Hydraulic Actuator

4. If using more than one Punch Head then fit the next Punch Head. Once fitted the phasing of the Punch Heads will be evident.

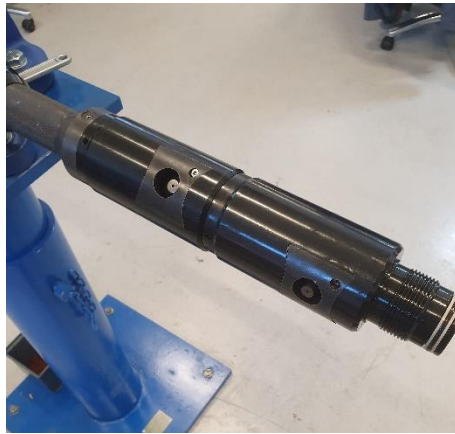

Figure 58 - Second Punch Head fitted

- Depending on the required phasing, the Punch Head may need to be shimmed. There are 2 available Shim Washer thicknesses, 0.5mm (which will change the phasing by 71°) and 0.1mm (that will change the phasing by 14°). Remove the Punch Head and fit as many Shim Washers required to get the desired phasing, up to a maximum of 2.5mm. Once the correct phasing has been achieved fit the Punch Head securely.



kaseum recommends the Punch Heads be aligned (0° phased) or equispaced (refer to *Table 2 - Recommended phasing angle* of this manual for guidance)



Figure 59 - Punch Head phasing images. The above example has been shimmed for 0° phasing

- If any additional Punch Heads are to be fitted then repeat the above steps until all Punch Heads are fitted and phased as required.

7. Fit the End Sub to the lowest Punch Head securely.



Figure 60 - End Sub fitment image

6.2 Oil Fill of K-Punch

Once fully assembled the **K-Punch** must be filled with suitable hydraulic oil, evacuating as much air from the hydraulic chamber as possible. Allowance must also be made for thermal expansion of the oil when used in hot environments.



Failure to oil fill the **K-Punch** correctly will result in an operation failure. The **K-Punch** must be filled with oil, ensuring as much air as possible has been evacuated and a 2" (51mm) thermal expansion gap has been included.



It is recommended to fill the **K-Punch** with a SAE 10W40 or ISO 32 grade oil.



The amount of oil required will be dependent on the amount of Punch Heads used. It is recommended to have at least 500ml of oil to fill the **K-Punch** for each operation

1. With the **K-Punch** assembled and in the vertical orientation, clamp the Outlet Sub in a vise if possible.



Figure 61 - Outlet Sub clamping image

2. Remove the Extension Sub assembly from the top of the Piston Housing.



Figure 62 - Extension Sub assembly image

3. Remove the End Sub and place a drip tray underneath the tool to catch excess oil as it exits the lowermost Punch Head.



Figure 63 - End Sub removal image

4. Using a large flat blade Screwdriver, remove the Piston Ring from the Piston Housing by levering the Piston Ring upwards using the machined slots for access.

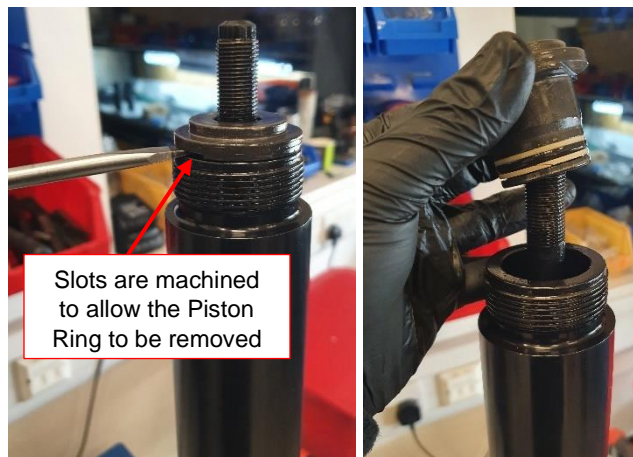

Figure 64 - Piston Ring removal image

- 5. In order to allow for thermal expansion during operation the **distance from the top of the Main Piston rod to the end face of the Piston Housing should measure 4" (100mm).**



Figure 65 - Images showing the fully seated position on the left (2"), and the position once the thermal expansion gap has been inserted (4")

- 6. Pour hydraulic oil into the Piston Housing until it is just below the top of the Piston Housing. Oil will begin exiting the lowermost Punch Head after a period of time, indicating that the hydraulic chamber is filled with oil.

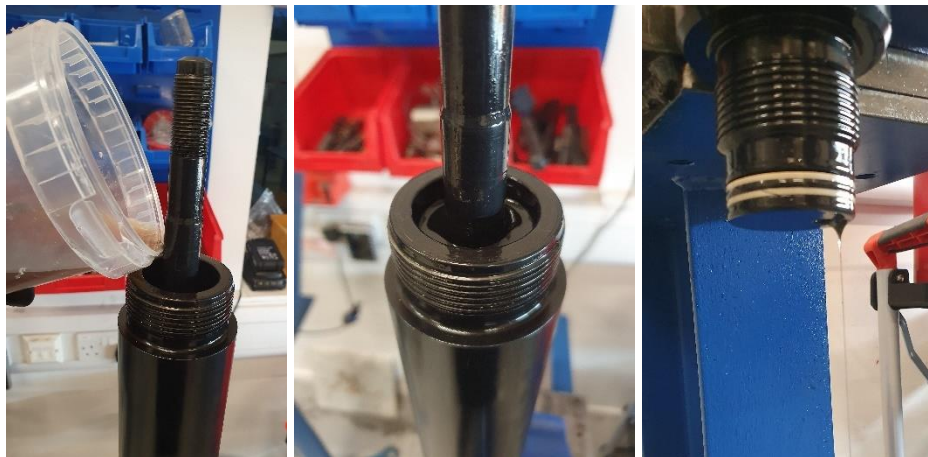

Figure 66 - Images showing oil fill

- 7. Ensuring that the Relief Shear Disc and Relief Piston are fitted into the End Sub, fill the End Sub with a small volume of oil and re-fit to the lowest Punch Head.

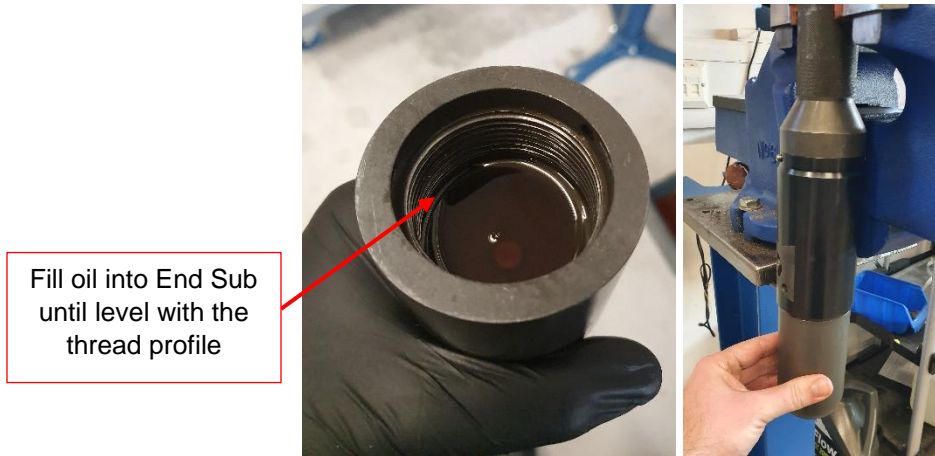

Figure 67 - End Sub oil fill and fitment

- 8. Top up the oil into the Piston Housing until the cavity is almost fill (leave approximately 0.5" (13mm) gap at the top).

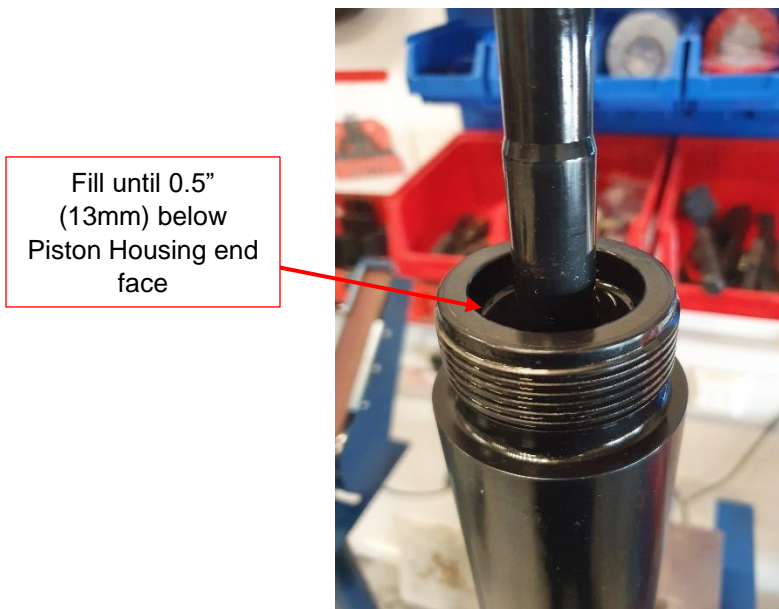

Figure 68 – End Sub oil fill image

9. Fit the Piston Ring into the Piston Housing ensuring that the 4" (100m) distance from the top of the Main Piston rod and Piston Housing end face is maintained. Now the Piston Ring is fitted the hydraulic chamber is sealed.

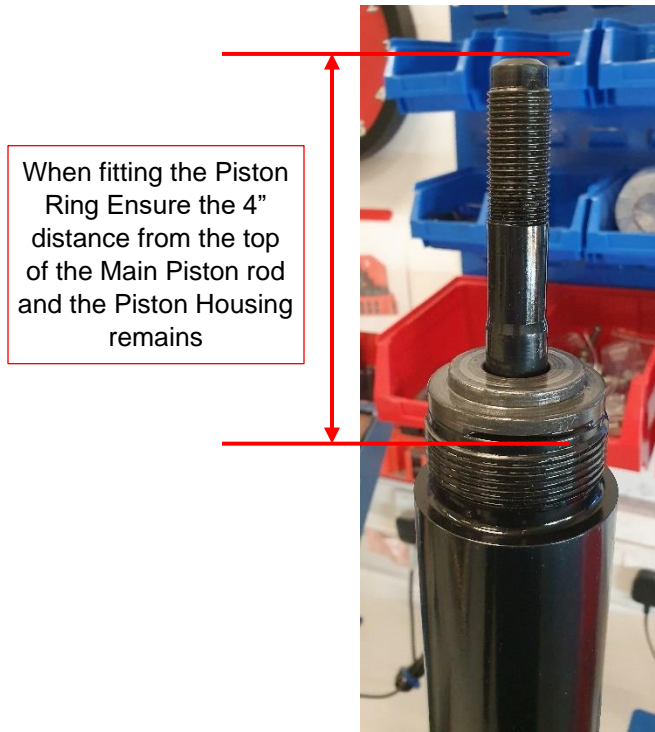

Figure 69 - Piston Ring fitment image

10. Push the Main Piston rod firmly down until it bottoms out. (Note, the Main Piston rod may travel back upwards as the chamber will be under a slight vacuum condition.) Re-fit the Extension Sub assembly.



Figure 70 - Extension Sub assembly image

This completes the oil fill procedure.

6.2.1 Interfacing the K-Punch to the K-Set

Prior to connecting the **K-Punch** to the **K-Set** it is recommended to perform a 'Surface Test' to ensure it is functioning correctly. Guidance on the 'Surface Test' procedure is explained in more detail in the 2.125" **K-Set** User Manual (**kaseum** part number 001878).

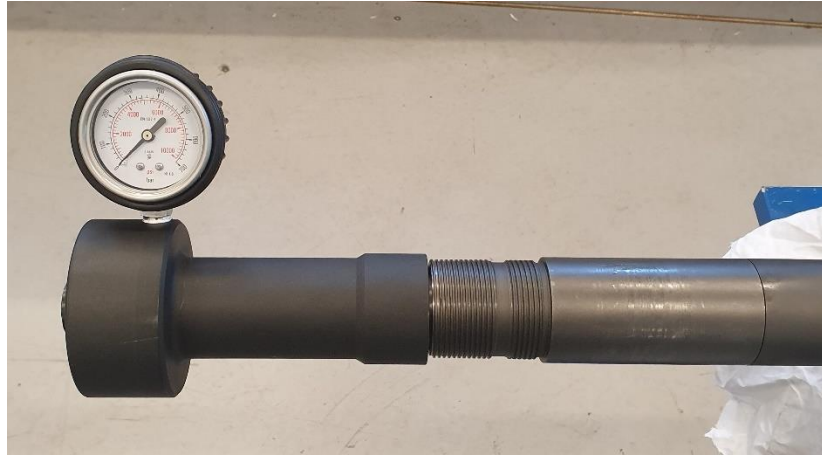

Figure 71 - Surface Test image

Also, prior to connecting the **K-Punch** to the **K-Set** the Lock Ring, if fitted, must be removed from the **K-Set**.



Failure to remove the Lock Ring will result in assembly issues as the make-up shoulder on the Main Piston will not align with the access hole in the Piston Housing.

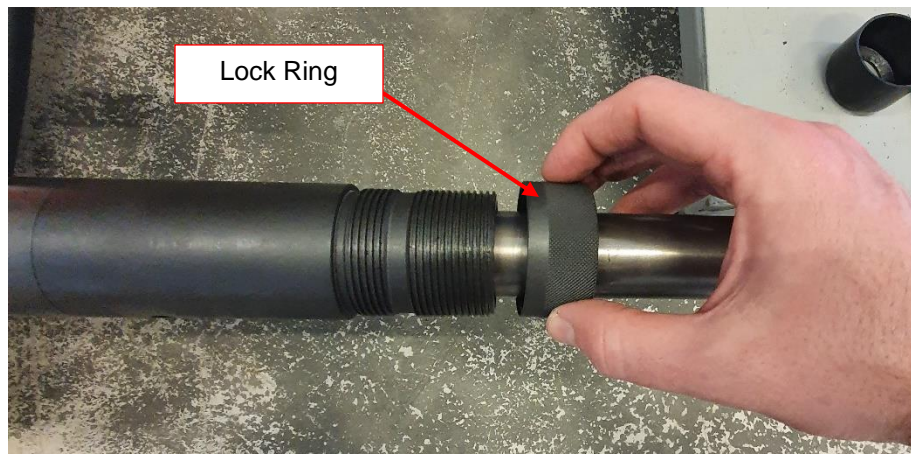

Figure 72 - Lock Ring image

The interfacing of the **K-Punch** to the **K-Set** procedure is as follows:

1. Once a successful 'Surface Test' has been conducted remove the Extension Sub assembly from the **K-Punch** and fit to the Lower Outer Adaptor of the **K-Set** securely.



Figure 73 - Extension Sub assembly image

2. Screw the Main Piston of the **K-Punch** to the **K-Set** Slick Rod. Insert a Pin Punch or similar through one of the holes on the Piston Housing to engage the make-up hole on the Main Piston shoulder. In order to engage the make-up hole, it is recommended to apply a small compressive force against the **K-Punch** (i.e. push the **K-Punch** towards the **K-Set**) this will ensure that the Main Piston is in the lowermost position and the make-up hole can be accessed.

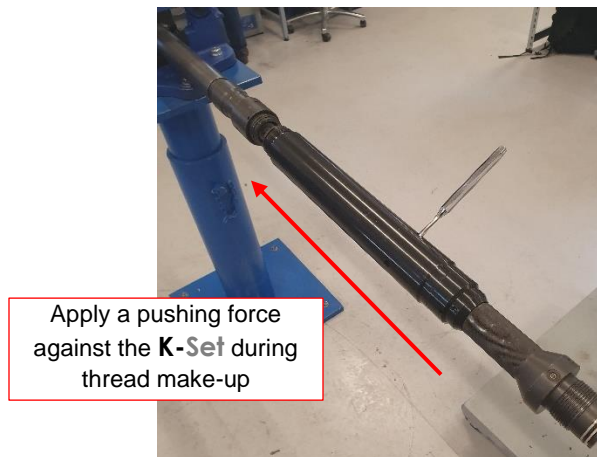

Figure 74 - Image showing Pin Punch inserted through Piston Housing to engage make-up shoulder

3. Secure the Extension Sub Retainer Cap onto the Piston Housing securely.



Figure 75 - Retainer Cap make-up image

4. Using a suitable Hex Key fit the all retaining Set Screws to the:
 - a. 2 off in Retainer Cap (Note these Set Screws are M10 x 6mm i.e. shorter in length than all the other retaining Set Screws)
 - b. 3 off in the Piston Housing
 - c. 2 off in each connected Punch Heads
 - d. 2 off in the End Sub

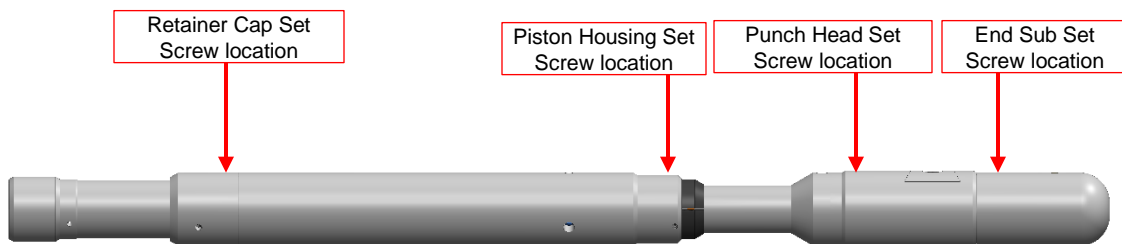

Figure 76 - Retaining Set Screw location image

6.3 Fitting the Punch Buttons

The Punch Button is held in place to the Punch Holder by means of a Spring Pin. The fitment of the Punch Button into the Punch Holder is dependent on an interference fit between the Spring Pin and the Punch Holder. If there is no interference between these two parts then there is a risk of the Punch Button coming loose prior to punching, therefore it is imperative to the success of the operation that there is interference between these two parts.

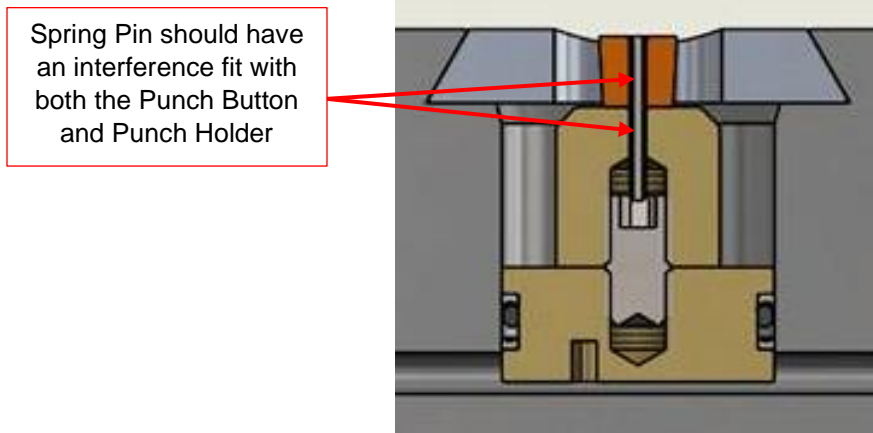

Figure 77 - Image showing Spring Pin interference points



When fitting the Punch Button into the Punch Holder by hand there should be a slight, but noticeable, resistance and when the Punch Head is held upside down with the Punch Button should remain secure.



Figure 78 - When help upside done the Punch Button should remain secure



The Punch Button and Spring Pin are consumable items and must be fitted prior to each operation.

To fit the Punch Buttons: -

1. The Punch Button should be supplied with the Spring Pin fitted. Note that the Punch Button has a trapezoidal shape and that the smaller diameter face should have the Spring Pin protruding.

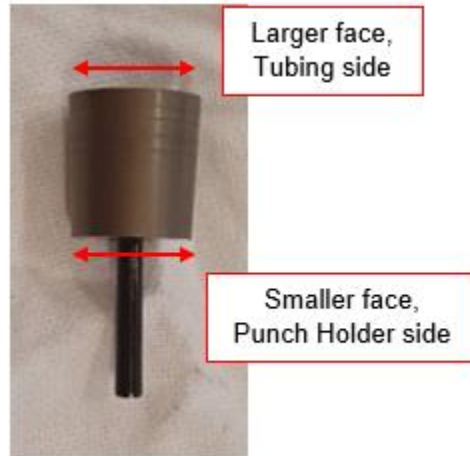

Figure 79 - Punch Button image

If the Spring Pin is not fitted, or damaged and needs to be replaced then a new Spring Pin should be fitted in to the larger face of the Punch Button and tapped through the centre hole. This will resize the Spring Pin ensuring it is the correct size for fitment in to the Punch Holder.



Figure 80 - Spring Pin installation images



The Punch Button **must be fitted** in the correct orientation; therefore, the correct fitment of the Spring Pin is operation critical

2. Align the Spring Pin with the Hole in the Punch Holder and push the Punch Button in by hand. Slight, but notable resistance should be felt during fitment. Ensure the Punch Button is fully seated on the Punch Holder.

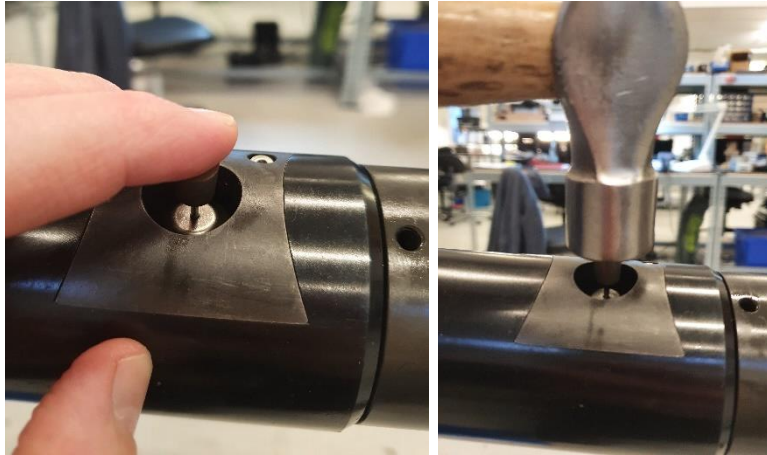

Figure 81 - Punch Button installation image



If there is no interference between the Spring Pin and Punch Holder then there is a risk of the Punch Button coming loose prior to punching. **DO NOT run the K-Punch with Spring Pins that have little or no interference** as it will cause operation failures

3. Once fitted securely ensure that the Punch Button is below the OD of the Punch Head Housing.

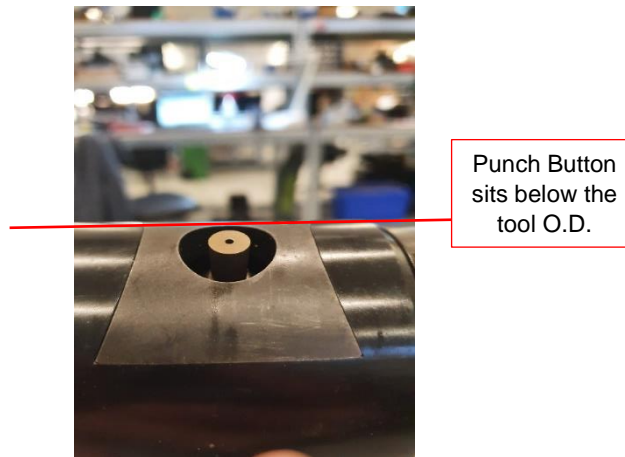

Figure 82 - Punch Button should not protrude past tool OD

4. Repeat this process until all Punch Buttons are fitted.
5. To limit the ingress of well debris around the Punch Pistons it is recommend to fill the void around the Punch Piston and Retainer Plate with a suitable high temperature grease (Shell Darina D2 or similar).

6.4 Fitment of the PCM

The final part of the **K-Punch** pre-deployment configuration is to fit the PCM to the **K-Set**. The **K-Punch** can be run in either E-Line Mode and commanded to Punch using the Surface Interface Box, or Slickline mode with a user set Countdown Timer delay. Programming and commanding of the PCM is explained in the following section of this manual.

The correct PCM and PCM Housing must be fitted to the top of the **K-Set**, along with any additional running string tooling, to complete the assembly of the running string ready for deployment.



Figure 83 - PCM fitted to K-Set

7 Programming and Initiation of K-Punch Commands

The **K-Punch** can be run in either E-Line Mode or Memory Mode. In E-Line mode the tool is commanded to function by the Surface Interface in real time. In Memory Mode the PCM is pre-programmed with a Countdown Time Delay which, once expired, will command the **K-Punch** to initiate. The programming and initiating of commands, along with installation and setup guidelines of the Surface Interface and **K-Log** software are explained in greater detail in the 2.125" **K-Set** User Manual (**kaseum** part number 001878). The following sections will only outline the differences from the 2.125" **K-Set** operation and the **K-Punch** operation.

7.1 Operating the K-Punch in E-Line Mode

The **K-Punch** is commanded using the Surface Interface Box (**kaseum** part number 000952).

1. With the E-Line mode PCM connected to the Surface Interface, select the 'Connect' icon on the Surface Interface home screen.

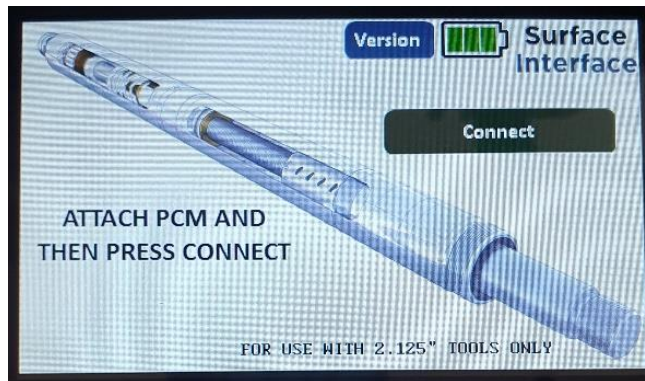

Figure 84 - Surface Interface Home screen image

2. After the Setting Tool size warning has been acknowledged the 'Operation Mode' screen will be populated.

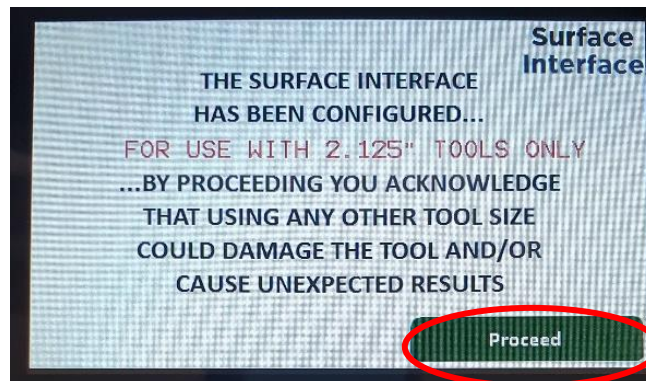

Figure 85 - Setting Tool size warning screen image

- 3. This screen will vary depending on the available configuration modes programmed within the Surface Interface box. For **K-Punch** the user must select the 'Punch' Select icon.

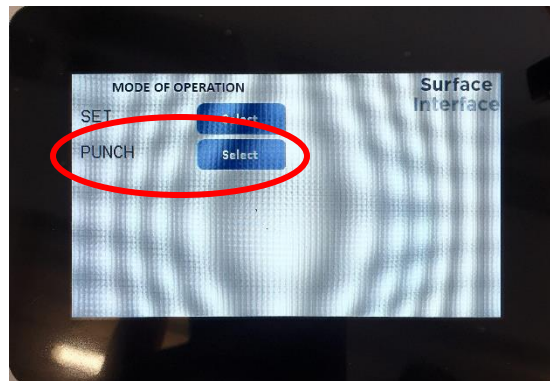

Figure 86 – E-Line Mode screen

- 4. Once the 'Punch' operation mode Select icon has been selected the E-Line mode screen will be populated.

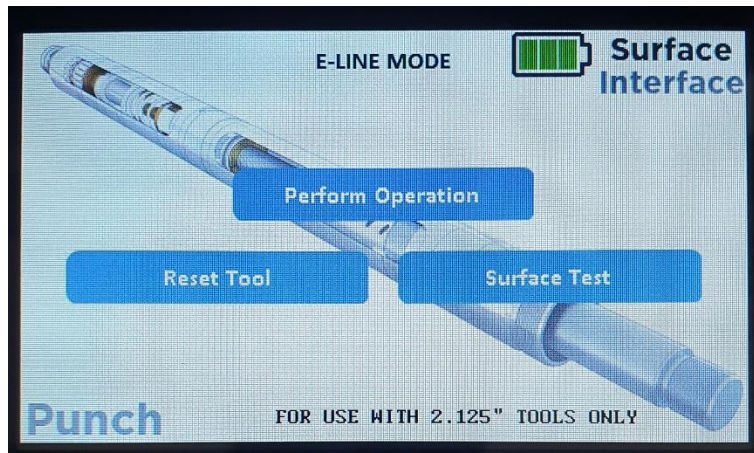

Figure 87 - Punch operation mode screen

7.1.1 Checking the PCM prior to use.

It is advisable to check the PCM is fit for use prior to performing any of the **K-Punch** functionality. To check the PCM is suitable:

1. Select the 'Perform Operation' command icon.

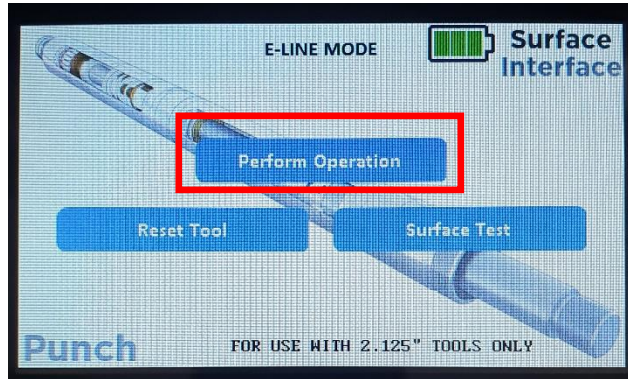

Figure 88 - Perform Punch command icon



The Real Time Data screen will be populated. Check that the populated Battery Voltage is greater than **32 Volts. If this value is less than 32 Volts then the PCM should be not be used**

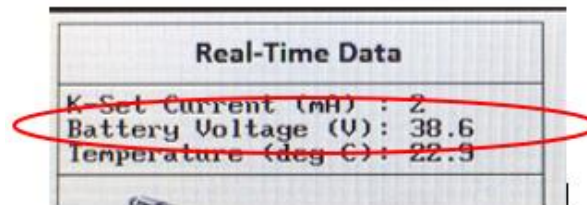

Figure 89 - Real Time Data screen

2. If the Battery Voltage is greater than 32 Volts select the 'Back' command icon to return to the E-Line Mode Home screen.

7.1.2 Perform Punch Real Time Data Screen

The main functionality of the **K-Punch** is accessed through the ‘Perform Operation’ icon. When this ‘Perform Operation’ icon is selected, the real-time data, along with the ‘Punch’ and ‘Retract’ commands are accessed:

1. Select the ‘Perform Punch’ icon on the E-Line Mode Screen.
2. The Real Time Data screen will be displayed. Real time channel data from the tool will be populated on the left-hand side of the screen, which is updated every second. There is also a graphic image of the **K-Punch** along with the current running status. When the **K-Punch** is initiating a Punch command the status message will read ‘**K-Punch** Punch’. When the **K-Punch** is initiating a Retract command the status message will read ‘**K-Punch** Retract’. When the **K-Set** motor is idle the message ‘**K-Punch** OFF’ will be populated. On the right-hand side of the screen there is a run timer which will begin counting up from 0 once a ‘Punch’ or ‘Retract’ command has been initiated. The default Punch and Retract durations, along with the default Punch and Retract current limits will also be displayed on the lower right-hand side of the screen. For the 3.5” tubing **K-Punch** these are:
 - Punch duration = 40 minutes.
 - Retract duration = 40 minutes
 - Punch Current Limit = 2500mA
 - Retract Current Limit = 2500mA



The tool current is a useful channel to monitor as it is directly related to the amount of pressure the **K-Punch** is generating. The higher the pressure the higher the tool current. A Punch Button penetrating through the tubing and shear events can be observed as sharp and instant tool current drops.

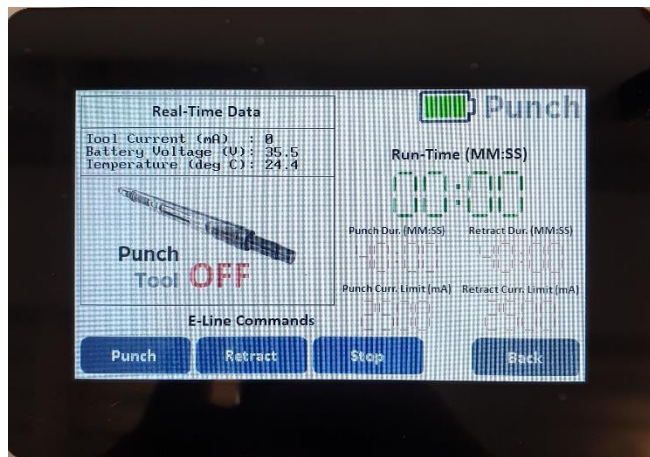

Figure 90 – Real Time Data screen format

3. Along the bottom of the screen there are 4 icons that can be selected by the user. They are:
 - **Punch.** The 'Punch' icon issues the Pull (set) command to the **K-Set**. Once the icon has been selected an additional confirmation screen will be displayed, ensuring confirmation that this command is indeed to be sent.

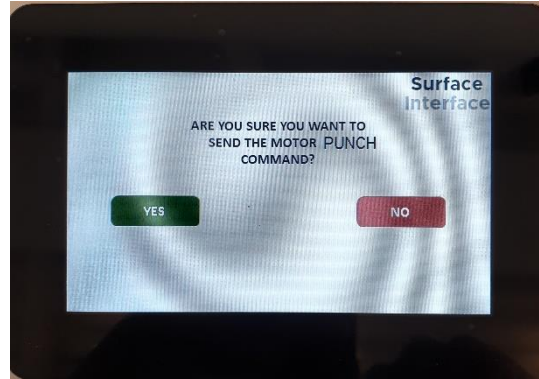

Figure 91 - Punch Command warning

- If the command is to be sent then the 'Yes' icon is to be selected. The Perform Punch screen will then be refreshed and the 'Punch Tool PUNCH' image will appear and the countdown timer will begin counting up.

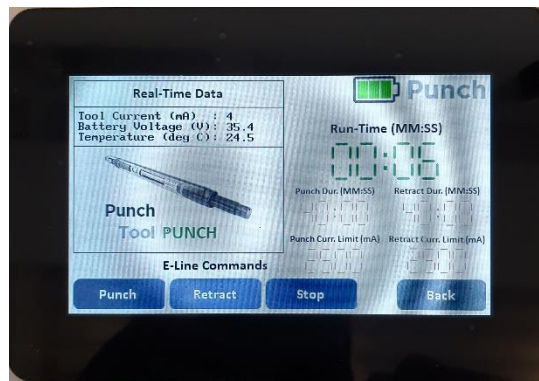

Figure 92 - Image showing K-Punch Punch message.

- If the command is not to be sent then 'No' should be selected and the screen will return to the E-Line Mode screen.



No power is sent from the Surface Interface to the **K-Punch**, only communication signals. Once the 'Punch' command has been issued the **K-Punch** will continue to perform the command until either the maximum motor run time (i.e. 40 minutes) or the maximum default current limit (i.e. 2500mA) has been reached, regardless if communication to the Surface Interface is maintained or lost.

- **Retract.** The 'Retract' icon issues the Push (Reset) command to the **K-Set**. Once the icon has been selected an additional confirmation screen will be displayed, ensuring confirmation that this command is indeed to be sent.

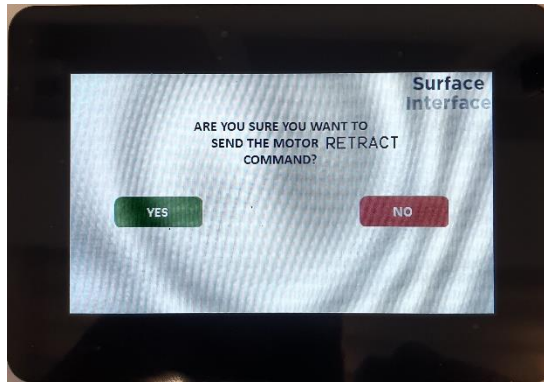

Figure 93 - Retract Command warning

- If the command is to be sent then the 'Yes' icon is to be selected. The Perform Retract screen will then be refreshed and the 'Punch Tool RETRACT' image will appear and the countdown timer will begin counting up.

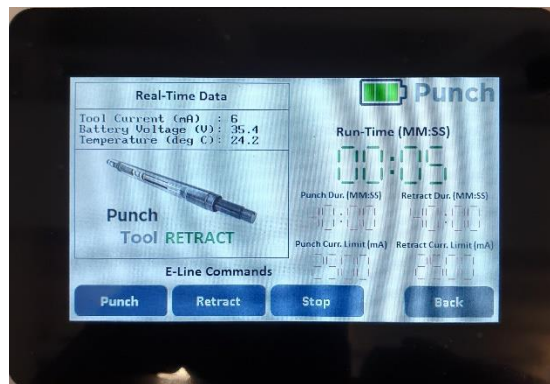

Figure 94 - Image showing K-Punch Retract message.

- If the command is not to be sent then 'No' should be selected and the screen will return to the E-Line Mode screen.



The 'Retract' command must always be issued after a Punch Command to aid in the Piston retraction. Failure to issue the Retract command may result in operational failures.



No power is sent from the Surface Interface to the **K-Punch**, only communication signals. Once the 'Retract' command has been issued it will continue to perform until either the maximum motor run time (i.e. 40 minutes) or the maximum default current limit (i.e. 2500mA) has been reached, regardless if communication to the Surface Interface is maintained or lost.

- **Stop.** The 'Stop' icon will stop any command (i.e. turn off the **K-Punch**). Once selected the command will stop immediately.

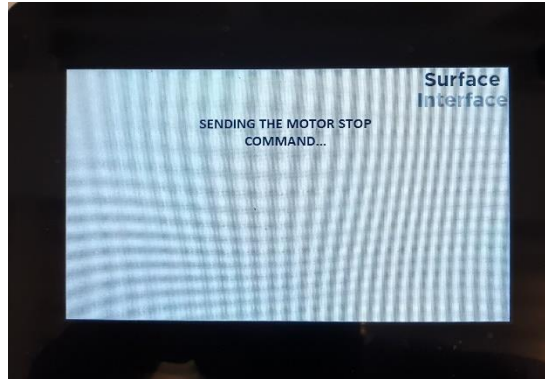

Figure 95 - Stop command warning message

- **Back.** The 'Back' icon will return the user back to the E-Line Mode screen.

7.1.3 Performing a Surface Test using the Surface Interface

In order to check the operational performance of the **K-Set** prior to interfacing the **K-Punch**, a 'Surface Test' can be performed, whereby the **K-Set** will pull against a test fixture (**kaseum** part number 001203), generating a load and an indication of the amount of load that has been generated. A 'Surface Test' command can be commanded from the Surface Interface by selecting the 'Surface Test' icon. For more information about the 'Surface Test' please refer to the 2.125" **K-Set** User Manual (**kaseum** part number 001878)

7.1.4 Performing a Reset using the Surface Interface

The **K-Set**, and if connected the **K-Punch**, is automatically 'Reset' by sending a 'Reset' command which will automatically drive the Slick Rod out to the lower stop limit. For more information about the Reset command please refer to the 2.125" **K-Set** User Manual (**kaseum** part number 001878)

7.1.5 Streaming Real Time data to K-Log

When using the **K-Punch** in E-Line mode the user can stream the real time data to the **K-Log** software application (**kaseum** part number 001229) to graphically view the tool data. This is done by connecting the Surface Interface to a computer with **K-Log** installed using a USB to USB-B cable (**kaseum** part number 001485). Once the cable has been connected:



Real Time data streaming can only be performed when the Surface Interface is in the 'Perform Operation' real time data screen.

1. Launch **K-Log** and create a new job, or load an existing job.



Figure 96 – K-Log Home Screen and Connect Screen

2. Select the 'Connect' icon.



Figure 97 – Connect icon

3. Once connected the data will be populated on a scrolling chart. The user can configure this chart to view different channels as required.

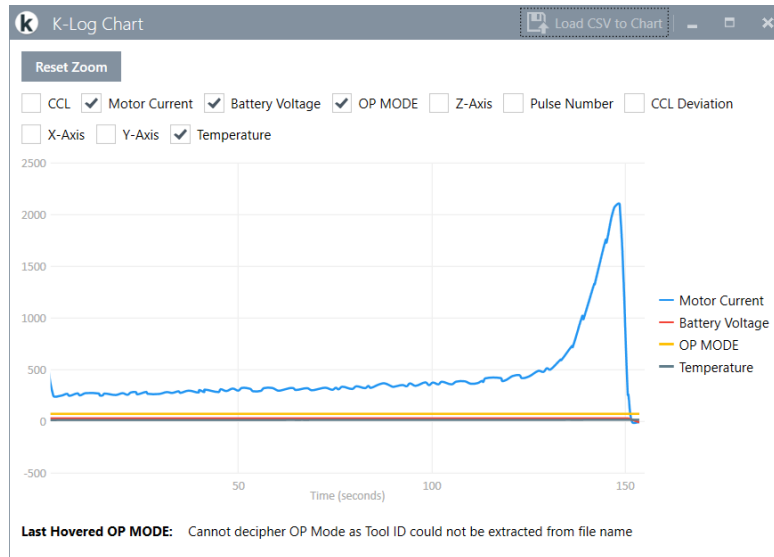

Figure 98 – Charting screen

4. Once the operation is complete the Disconnect icon on the K-Log home screen should be selected. The streamed data will be saved in the job folder for future reference.

7.2 Operating the K-Punch in Slickline Mode

In Slickline Mode the user must program all commands to the PCM using either the **K-Log** Software application or the Surface Interface. Once programmed and connected to the tool the command will be initiated after a Countdown Time Delay has expired. The Countdown Time Delay for the 'Reset' and 'Surface Test' commands are hard coded at 1 minute. The 'Program Tool' Countdown Time Delay must be set by the user. The programming and initiating of commands are explained in more detail in the 2.125" **K-Set** User Manual (**kaseum** part number 001878) the following sections will only outline the differences from the 2.125" **K-Set** operation and the **K-Punch** operation.

7.2.1 Programming in Slickline Mode using the Surface Interface

When the PCM is connected to the Surface Interface using the micro USB cable (**kaseum** part number 001223) the PCM can be programmed with a command.

1. Connect the PCM to the Surface Interface using the micro USB interface cable.
2. Select the 'Connect' icon on the Surface Interface Home screen. Once the **K-Set** warning screen has been acknowledged the Slickline Mode screen will be populated. Select the 'Program Tool' command icon:

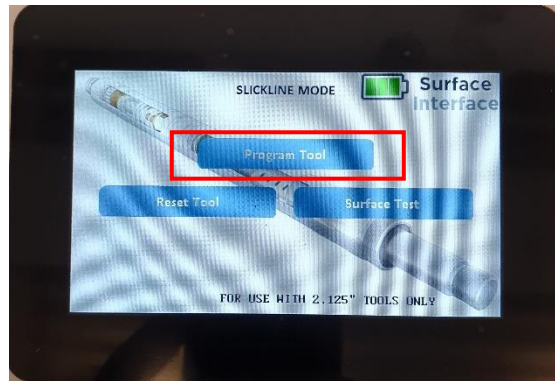

Figure 99 - Slickline Mode screen

- 3. A list of available programming configurations will be populated. Select the 'Punch' profile command icon.

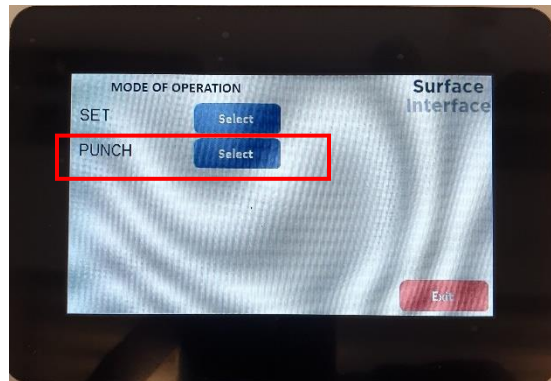

Figure 100 - Punch configuration

- 4. The Countdown Time Delay must be set by the user. Increment the Countdown Time Delay required using the plus (+) and minus (-) icons until the required delay is populated.

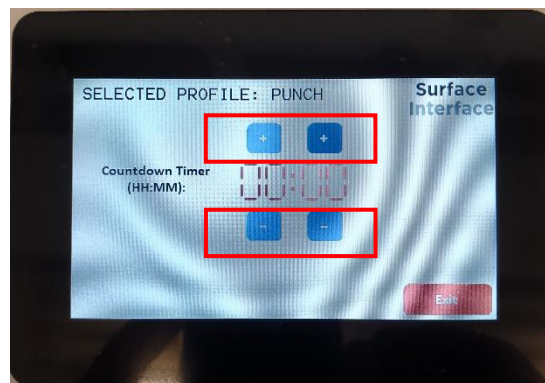

Figure 101 – Countdown Timer Increment icons

- 5. Once the required Countdown Timer has been inputted select the 'Proceed' icon.

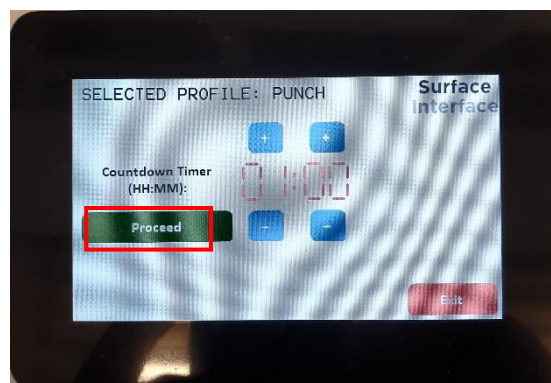

Figure 102 - Example of a 1-hour Countdown Timer and the Proceed icon location

- 6. An additional message will be populated ensuring that the correct Countdown Timer has been selected and the command is to be programmed to the PCM. Select the 'Yes' command icon to proceed. Selecting the 'No' icon will return the user back to the Home Screen and no programming will be conducted.

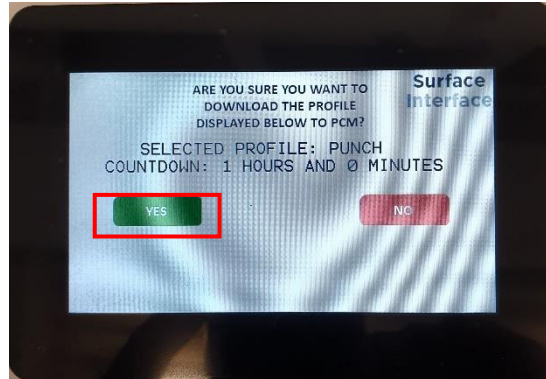

Figure 103 - Configuration warning message

- 7. The Punch configuration will be programmed to the PCM. This will take approximately 90 seconds to complete.

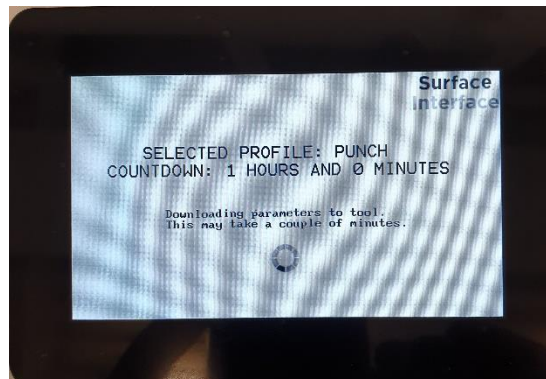

Figure 104 - Programming message

8. Once the Countdown has been applied a successful warning message will be populated. The PCM is now programmed and can be disconnected from the Surface Interface.

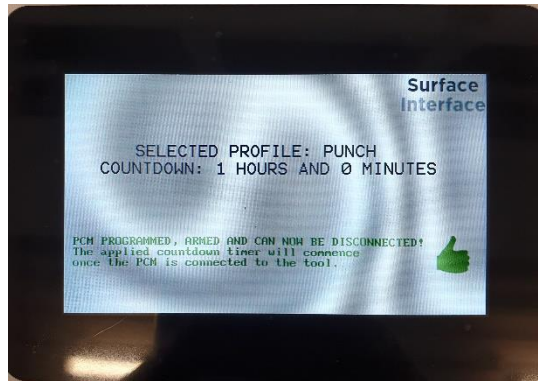

Figure 105 - Successful programming message

7.2.2 Programming in Slickline Mode using K-Log

The following procedure outlines how to program the 'Punch' command in **K-Log**.

1. Connect the PCM to the computer using the micro USB interface cable. Launch **K-Log** and create a new job, or select an existing job.



Figure 106 – K-Log Home Screen and job selection screen

2. Select the 'Connect' icon.



Figure 107 – Connect icon

3. The operation drop-down list will be populated. Select '2.125" Punch' option from the list and select the 'Confirm' icon.

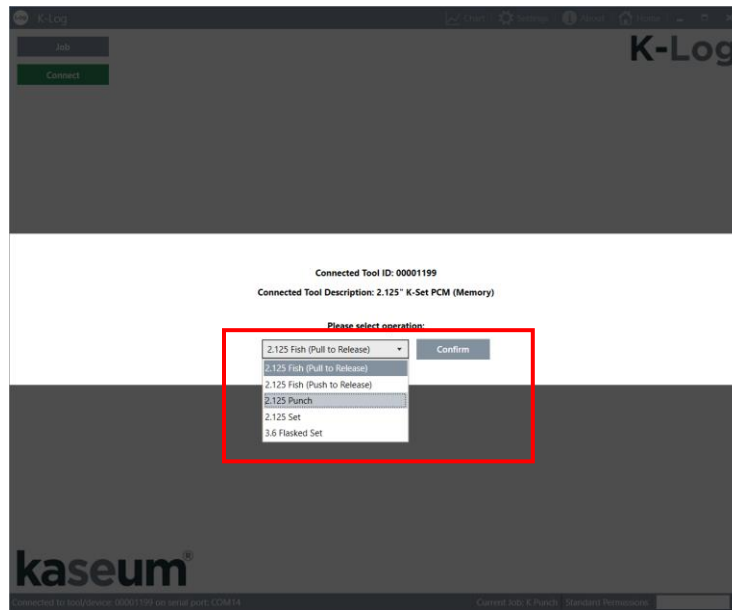

Figure 108 - Operation drop down list

The 'Punch' command when programmed in Memory mode will perform the entire punching cycle (i.e. 'Punch' and 'Retract'). To program the punching cycle command:

1. The Memory Menu will now be visible. Select the 'Program' Icon

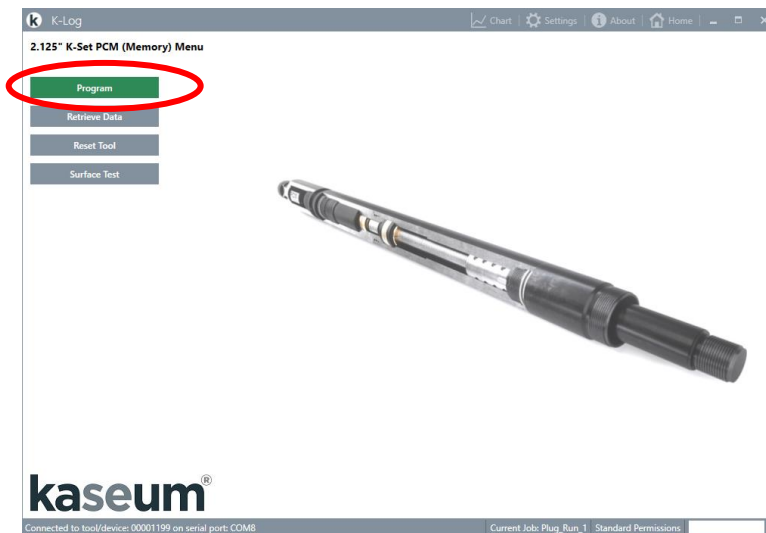

Figure 109 - Program command icon

- 2. Enter the Countdown Time Delay required **in minutes** into the 'Set Countdown Timer' Box. Note: the software will only accept a numerical value in minutes. Once the Countdown Timer value has been correctly entered, click on the 'Program' command icon and programming will commence.

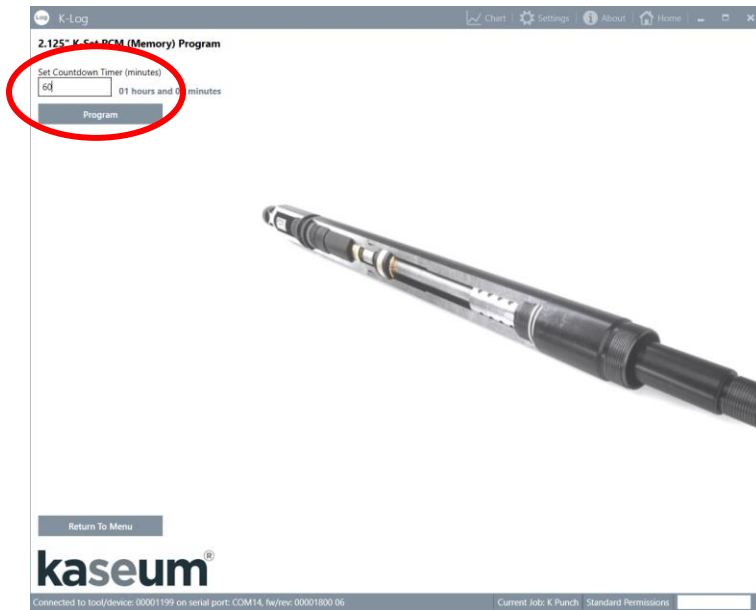

Figure 110 – Program tool screen

- 3. Once complete, a successful completion status message will be populated in the lower command bar.



Figure 111 – Programming success message image

- 4. A pdf. verification report will also be populated and saved to the job folder, which outlines all the programmed parameters of the PCM.

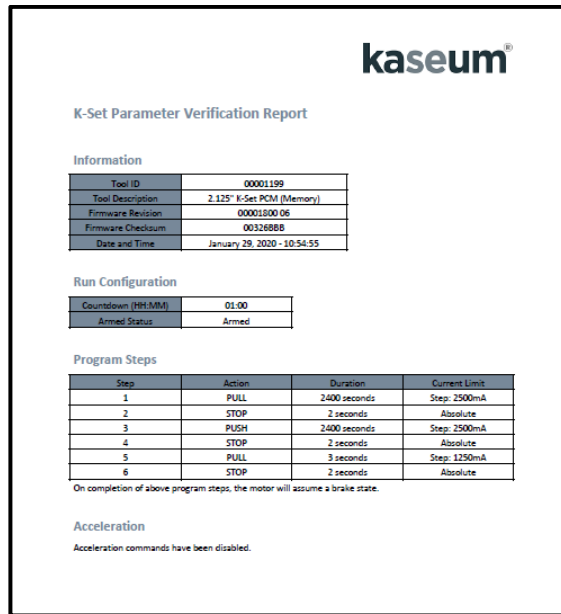

Figure 112 – Example Verification report



The PCM **should not be used** if any error message is populated in the verification report.

Program Steps

Step	Action	Duration	Current Limit
1	PULL	2400 seconds	Step: 2500mA
2	STOP	2 seconds	Absolute
3	PUSH	2400 seconds	Step: 2500mA
4	STOP	2 seconds	Absolute
5	PULL	3 seconds	Step: 1250mA
6	STOP	2 seconds	Absolute

On completion of above program steps, the motor will assume a brake state.

Figure 113 – Example program step array for K-Punch

7.2.3 Programming a 'Surface Test' command in K-Log

In order to check the operational performance of the **K-Set** prior to interfacing the **K-Punch**, a 'Surface Test' can be performed, whereby the **K-Set** will pull against a test fixture (**kaseum** part number 001203), generating a load and an indication of the amount of load that has been generated. For more information about the 'Surface Test' please refer to the 2.125" **K-Set** User Manual (**kaseum** part number 001878)

7.2.4 Programming a 'Reset' command in K-Log

The **K-Set**, and if connected the **K-Punch**, is automatically 'Reset' by sending a 'Reset' command which will run the Slick Rod out to the lower stop limit. For more information about the Reset command please refer to the 2.125" **K-Set** User Manual (**kaseum** part number 001878)

7.3 Retrieving data from the PCM.

After an operation is complete the run data will be stored on both the E-Line and Slickline PCM's.



PCM data can only be uploaded in **K-Log** and cannot be uploaded to the Surface Interface.

1. In the Memory menu of **K-Log** select the 'Retrieve Data' command icon

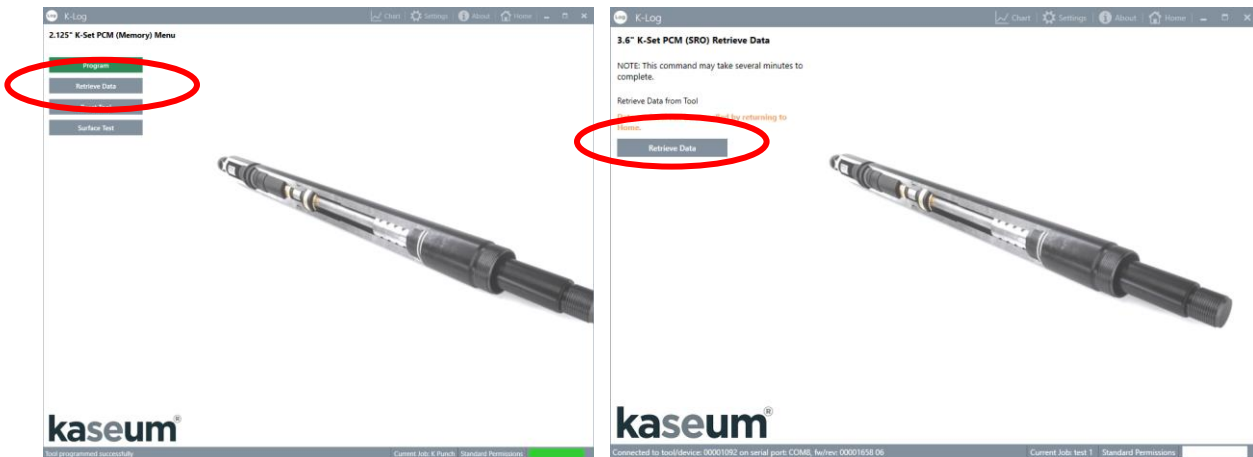

Figure 114 - Retrieve data command icon. Image on left shows Slickline functionality and image on right shows E-Line functionality

- 2. An additional warning message will be populated, outlining that the data retrieval process may take several minutes depending on the dataset size. Once this warning has been observed select the 'Retrieve Data' command icon. Once the data has been retrieved from the PCM it will be saved in the Job folder named with the date and time of when the file was uploaded, and formatted with a .csv file extension.



Figure 115 - Retrieve data icon

- 3. This data can be viewed in the K-Log charting software. Select the 'Chart' icon from the top bar of the K-Log window.

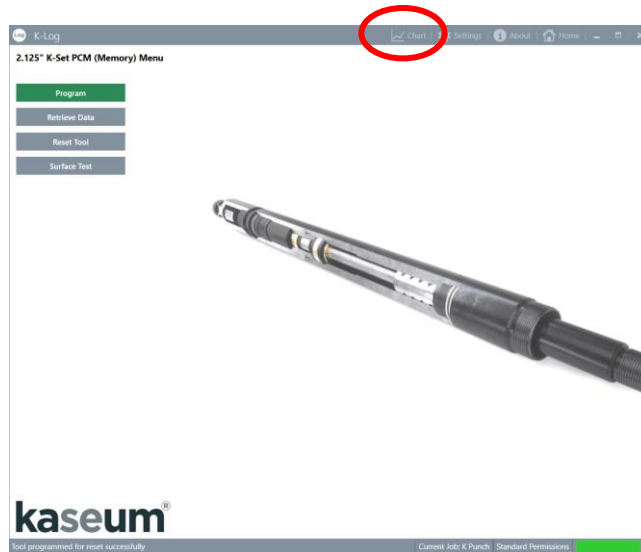

Figure 116 - Chart icon

- 4. The charting window will be populated. Select the 'Load .csv to Chart' icon

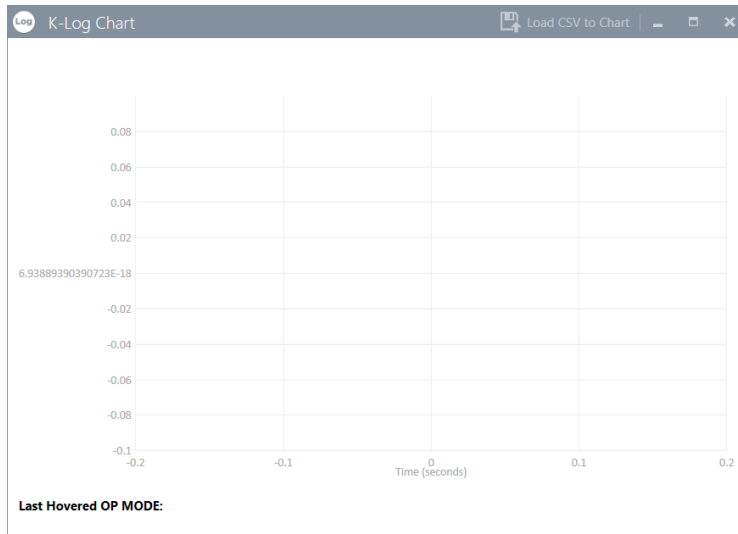

Figure 117 - Chart window

- 5. When prompted navigate to the uploaded file and select. The data will be graphically populated for viewing.

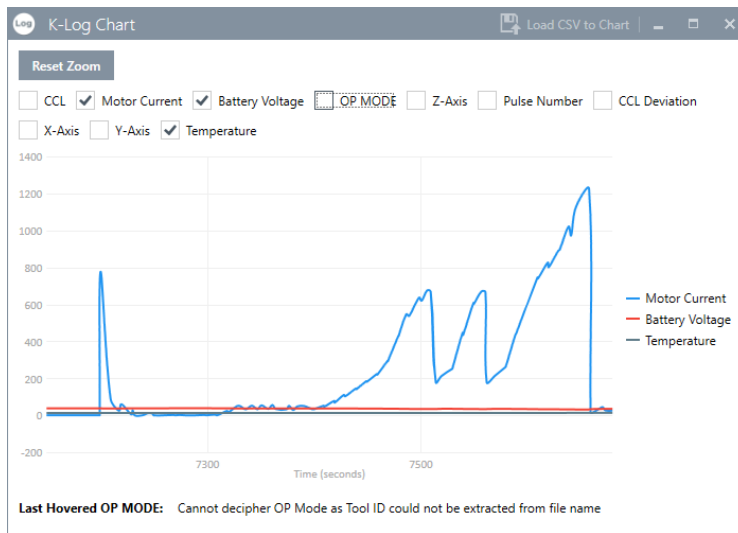

Figure 118 - Dataset viewed in Chart window

8 Deployment of K-Punch

The following procedure describes the operational steps of **K-Punch**:

1. Assemble the Hydraulic Actuator assembly as described in section 5.1 *Hydraulic Actuator general assembly procedure* of this manual. Ensure that the Emergency Shear Ring, Relief Shear Disc and A.F.O. Plug are fitted correctly.
2. Assemble the Punch Head, or Heads, as described in section 5.2 *Punch Head general assembly procedure* of this manual
3. Oil fill the **K-Punch** as described in section 6.2 *Oil Fill of K-Punch* of this manual.
4. Connect the **K-Punch** to the **K-Set** as described in section 6.2.1 *Interfacing the K-Punch to the K-Set* of this manual.
5. Fit the Punch Button(s) and PCM as described in section 6.3 *Fitting the Punch Buttons* and 6.4 *Fitment of the PCM* of this manual.

The tool string is now ready for deployment

6. Deploy the running string to the required punching depth. When at punching depth the tool must remain stationary.



When the punching cycle (i.e. 'Punch' and 'Retract') commands are being conducted it is vital that the **K-Punch** remains stationary. If any axial movement is applied to the tool string during the initiation of the punch command the Punch Buttons may become dislodged and cause an operational failure.

7. The 'Punch' command can now be initiated.

In Slickline Mode

8. Wait for the Countdown Time Delay to expire and the punching cycle will be conducted. During the initiation of the punching cycle the 'Punch' and 'Retract' commands will be performed, therefore at least **50 minutes** needs to be allowed **after** the Countdown Time Delay has expired. During this time monitor all external indications (e.g. tool weight indicator fluctuation, tubing and annulus pressure changes) which may infer that the Punch Button has penetrated the tubing. After 50 minutes have expired the running string can be recovered to surface

In E-Line Mode

9. Whilst stationary, initiate a 'Punch' command. Monitor the tool current during the operation. The tool current will rise as the internal hydraulic pressure rises. The current will continue to rise until the Punch Button penetrates the tubing, this will be evident as a sudden drop in pressure, and therefore a sudden drop in current. After all the Punch Buttons have penetrated the tubing another shear event will be seen as the Shear Disc yields. At the end of the stroke the **K-Punch** will automatically power down.
10. After the 'Punch' command has been completed initiate a 'Retract' command. This will push the Main Piston downwards, increasing the hydraulic chamber volume and therefore lowering the chamber pressure, allowing the Punch Pistons to be retracted. Once at the end of the stroke the tool will power down automatically and the hydraulic chamber pressure will be vented.

11. The running string can now be recovered to surface.

12. Once back at surface the Punch Pistons should be retracted back inside the Punch Head. Remove the **K-Punch** from the **K-Set**.



There is a slight risk that the **K-Punch** may have trapped pressure upon returning to surface, this may be evident as the Punch Pistons not being fully retracted or connections may be tight during disassembly. In this unlikely event the A.F.O Plug can be vented to allow the pressure to be safely released. Using a 1/4" Hex Key slowly crack open the A.F.O Plug ensuring the vent port is facing away from any personnel. If there is any concern in regards to internal pressure still be present inside the **K-Punch** then vent the A.F.O. Plug prior to disassembly.

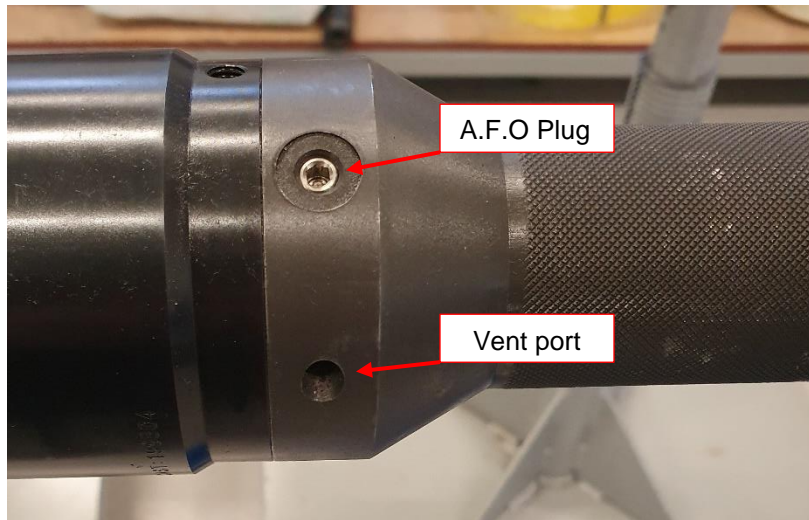

Figure 119 - A.F.O. Plug and vent port image

13. Fully disassemble the **K-Punch** in preparation for additional operations.

9 Periodic and Routine Service Instructions of K-Punch

9.1 Post Run Maintenance of the K-Punch

After each operation the **K-Punch** should be fully stripped down, cleaned and inspected. Visibly check for any signs of damage or wear. If any damage is evident it should be addressed and rectified prior to any additional operations.

After each deployment it is recommend to change out all the items that are called out in the redress kit as well as the standard K-Set consumables. These include: -

- All elastomeric sealing O-rings,
- Back Up rings on the Relief Piston
- Relief Shear Disc
- Punch Button(s) and Spring Pin(s)
- PCM
- Motor Module O-rings.

Refer to the assembly procedure as described in section 5 *K-Punch General Assembly*, as well as the relevant assembly drawing, for information and guidance on this procedure. (The disassembly procedure is the reverse of the assembly procedure.)

The following redress kits are available from **kaseum**:

5. Redress Kit – **K-Punch** Hydraulic Actuator. (**kaseum** part number 002328)
6. Redress Kit – **K-Punch** Head. (**kaseum** part number 002442)

Additionally, prior to redressing the elastomers it is best practise to remove the fragments of Relief Shear Disc and Spring Pin from the tool:

9.2 Shear Disc removal post run

1. Remove the End Sub from the Punch Head.



Figure 120 - End Sub image post run

2. Remove the Bull nose from the End Sub. There should be a circular fragment of the Relief Shear Disc in the bottom on the End Sub.



Figure 121 - Circular Relief Shear Disc fragment

3. Place the End Sub upside down on a flat surface. Using a Pin Punch through the centre access hole, punch the Relief Piston out of the End Sub.



Figure 122 - Pin Punch through the End Sub to remove the Relief Piston image

4. When the Relief Piston is removed there should be 3 segments of the Relief Shear Disc. If the segments of Relief Shear Disc do not come out with the Relief Piston then they will need to be removed from the End Sub Port. Place a thin pick or similar into the centre access port and punch the segments out.



Failure to remove the segments of Relief Shear Disc will result in assembly issues for future operations.

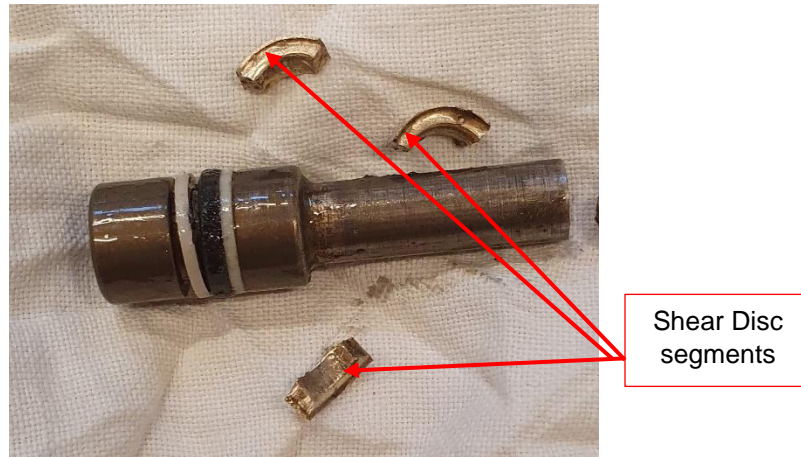

Figure 123 - Shear Disc segment image

9.3 Spring Pin fragment removal post run

After deployment part of the Spring Pin that retain the Punch Button may be lodged in the Punch Holder and should be removed.



Figure 124 - Punch Holder with fragment of Spring Pin images

1. Remove the Cap Screw from the Punch Head and slide off the Retainer Plate.

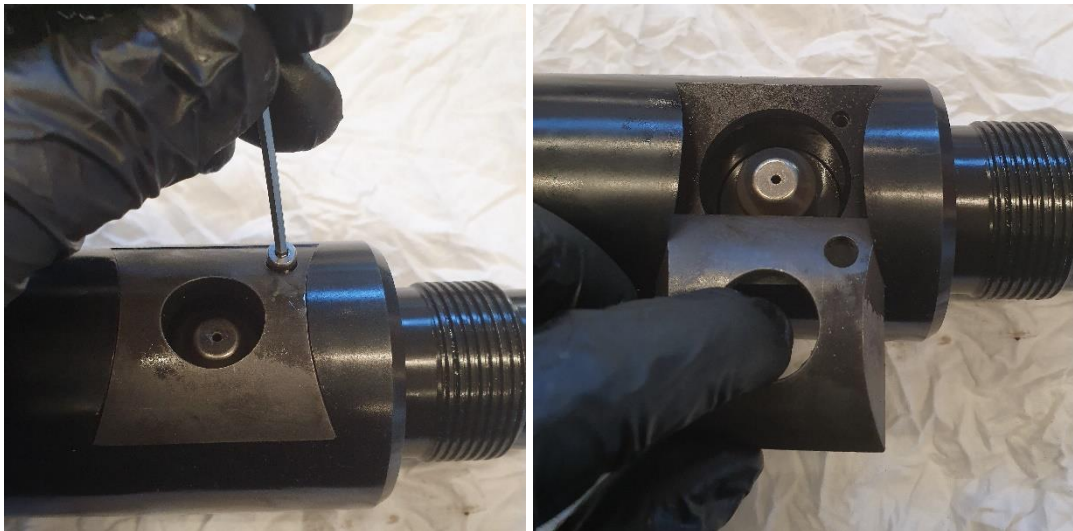

Figure 125 - Retainer Plate removal image

- Using Pliers or similar, pull the Punch Holder and Punch Piston out of the Punch Housing.



Figure 126 - Punch Piston removal images

- Using an open-ended Spanner and a large flat bladed Screwdriver, unscrew the Punch Holder from the Punch Piston.



Figure 127 - Punch Holder removal image

- Using a 2mm Pin Punch or similar, punch the remaining part of Spring Pin out of the Punch Holder.



Figure 128 - Spring Pin removal images

- Repeat this process for all Punch Holders.

10 Field User Golden Rules

1. The **K-Punch** is designed to be deployed within a specific size and grade of tubing. If the **K-Punch** is used in tubing out with this specification, or mechanically unconstrained (i.e. deploying the Punch Button without it contacting a solid surface) then the Punch Head Retainer Plate will fail and cause a catastrophic failure of the system. **The K-Punch should only be deployed within the correct size of tubing.**
2. Ensure the Punch Button(s) are fitted prior to deployment.
3. As well as the elastomeric seals, the Relief Shear Disc, Punch Button and Spring Pin are all consumable parts and must be replaced after each deployment.
4. Always check the A.F.O plug fitted is tight prior to deployment. Failure to fit the A.F.O. Plug, or fit securely, will result in an operational failure.
5. When initiating a 'Punch' command ensure the running string is stationary. Do not move the running string until the 'Punch' command is complete.
6. During general assembly of the **K-Punch** always check the Tubing Nut is tight on the Main Piston.
7. Ensure the dynamic sealing faces of the Main Piston and Tubing Nipple are free from marking and damage. If any damage is visible **do not use** these parts and replace immediately.
8. When filling with oil prior to deployment it is best practise to secure the tool vertically with the End Sub in the lowermost position. This will aid the evacuation of air more effectively.
9. During the oil fill process and prior to refitting the End Sub, fill the End Sub with oil to eliminate the possibility of introducing an air pocket.
10. Check that the Shear Disc fragments have been removed prior to fitting a new Shear Disc. When fitting the Shear Disc and Relief Piston ensure that it fits flush with the face of the End Sub.
11. Always check the Punch Holder is clear and previous Shear Pin fragments have been removed.
12. After the 'Punch' command has completed always initiate a 'Retract' command.
13. Fill the void around the Punch Piston with a suitable high temperature grease to mitigate debris ingress.
14. Prior to each deployment check the condition and stamped shear rating of the Emergency Shear Ring.
15. If a situation arises where the tool is stuck downhole and the Emergency Shear Ring is to be released then this can be done by **jarring up** on running string.
16. If there is any concern in regards to possible trapped pressure within the tool when at surface then open the A.F.O. Plug.
17. Ensure that the retaining Set Screws in the Retainer Cap, Piston Housing, End Sub and all Punch Heads are fitted prior to deployment and removed prior to disassembly. Note that the retaining Set Screws on the Retainer cap are shorter in length than all the others.
18. Ensure the Lock Ring, if fitted, is removed from the **K-Set** prior to interfacing of the **K-Punch**.

11 REFERENCE DRAWINGS

11.1 Assembly Drawing 002325

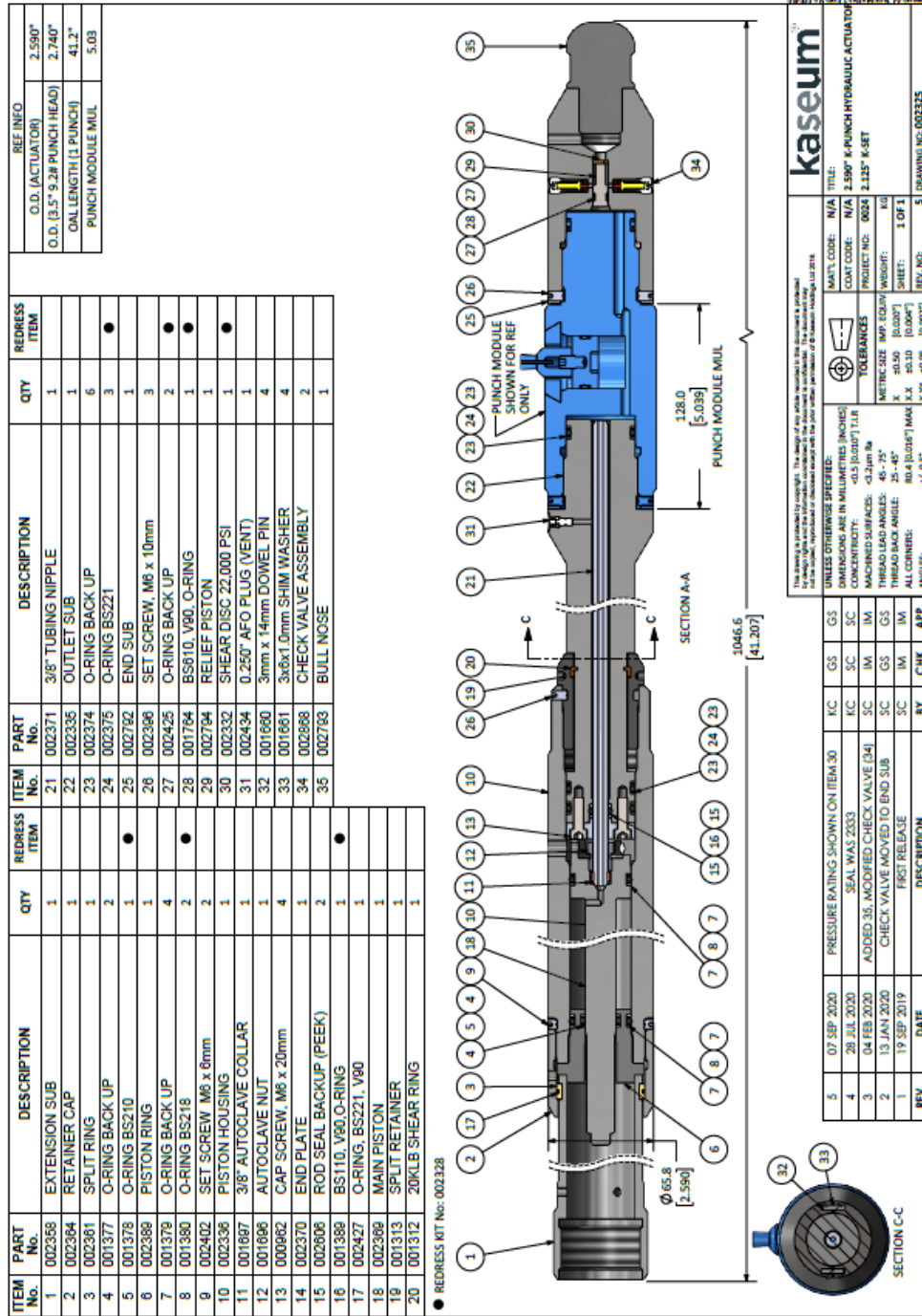

11.2 Assembly Drawing 002326

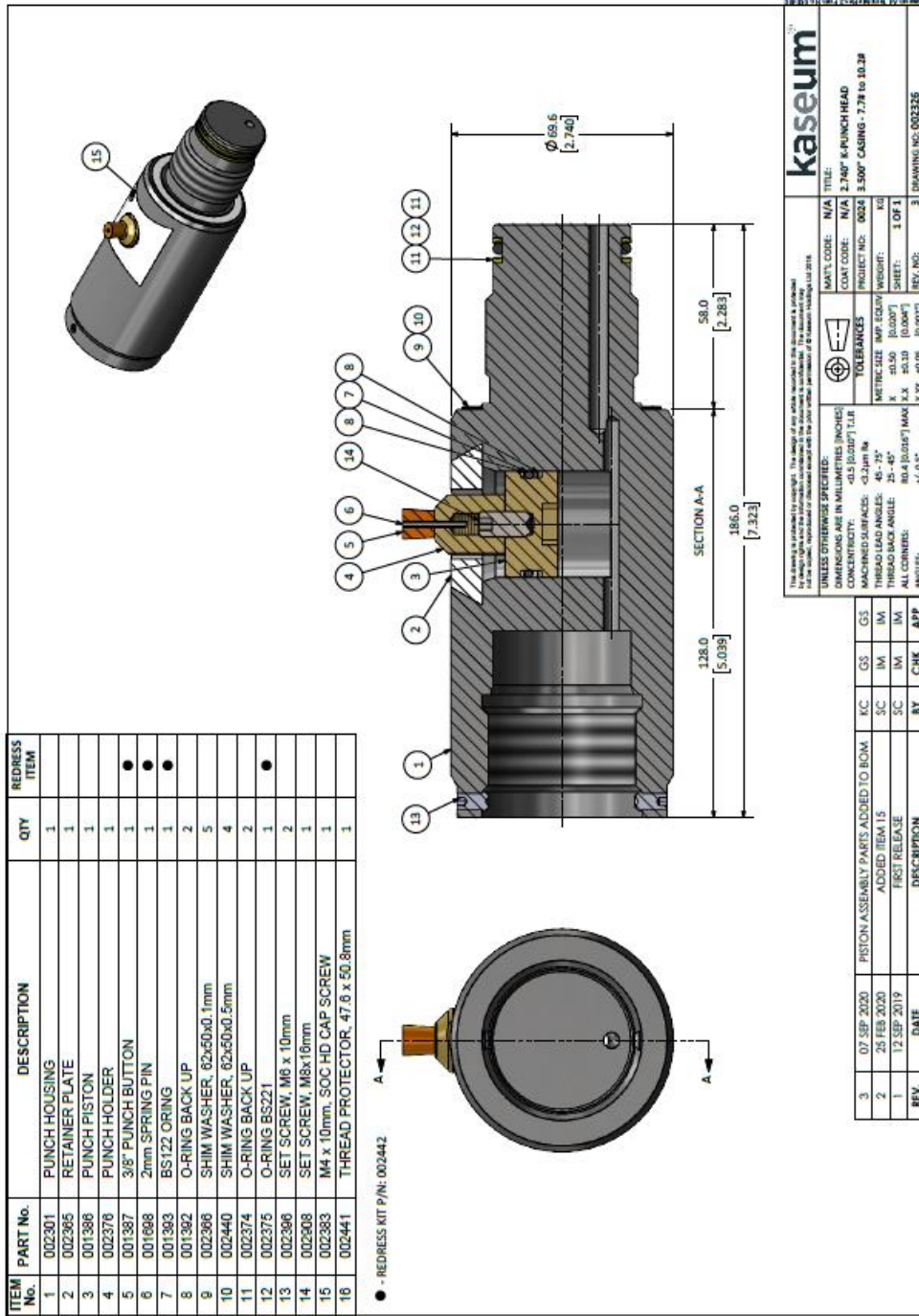

11.3 Assembly Drawing 002656

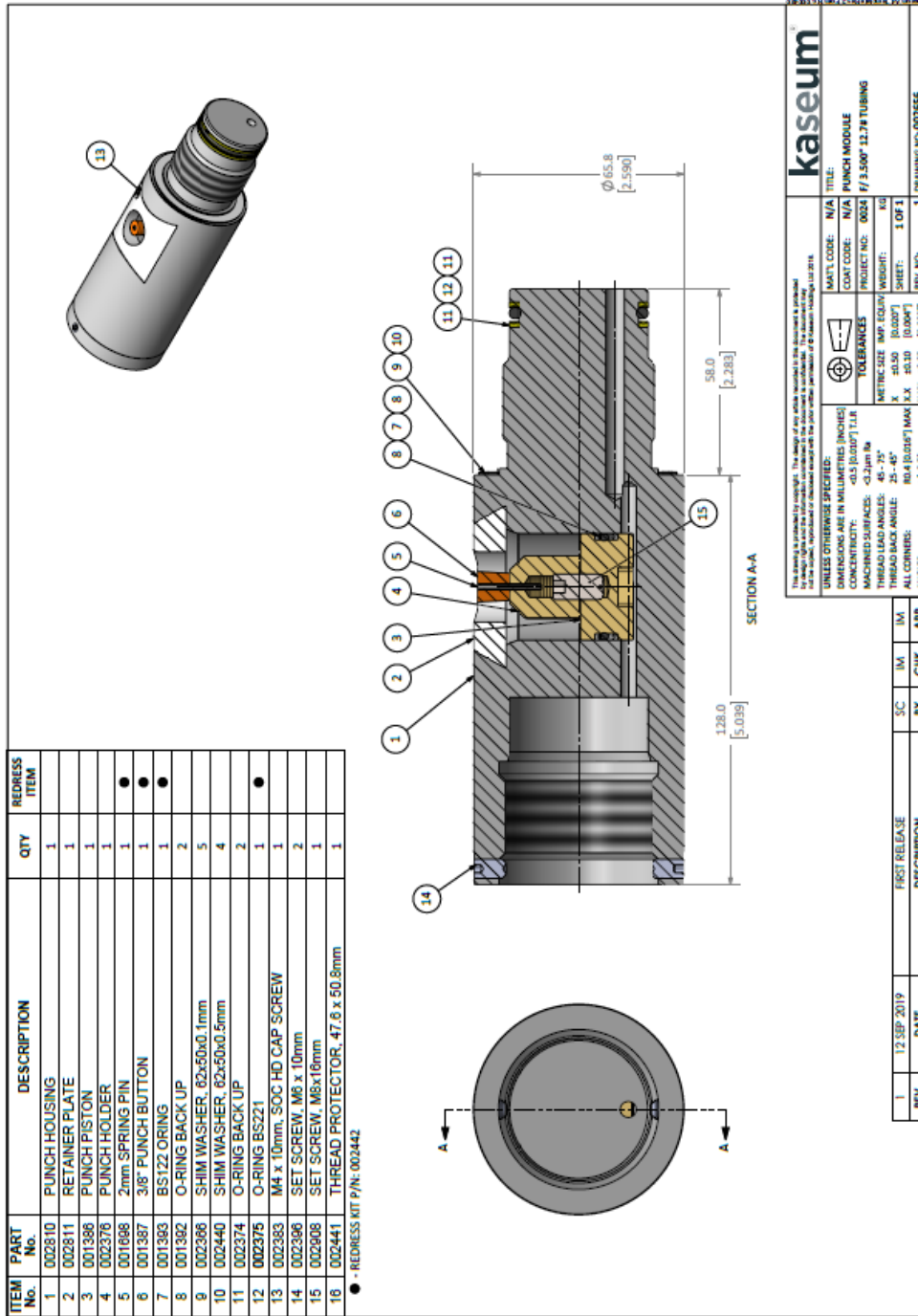

11.4 Assembly Drawing 002868

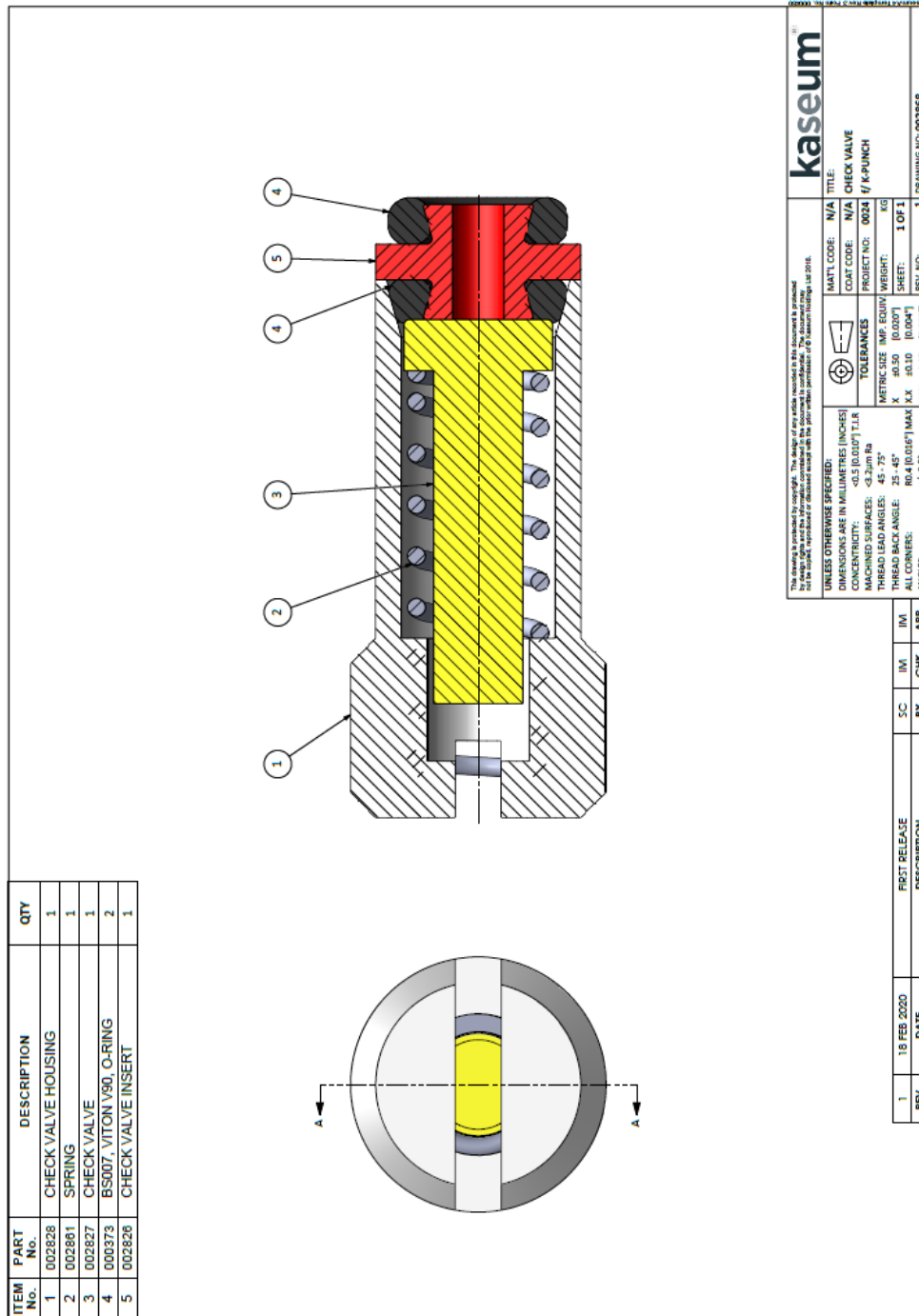

12 APPENDIX A- Definitions, Acronyms, Abbreviations and References

Define all terms, acronyms, and abbreviations used in this document.

K-Set	kaseum Setting Tool Product Line
K-Punch	kaseum Punch Tool Product Line
PCM	Power and Comms Module
Surface Interface	Surface Read Out Interface Box Assembly
A.F.O. Plug	Axial Force Only Plug

References

The following parts have been referenced in this manual:

<u>kaseum Part Number</u>	<u>Description</u>
002325	3.5" K-Punch Hydraulic Actuator
002326	3.5" K-Punch Head f 7.7# and 10.2#
002656	3.5" K-Punch f 12.7# Tubing
002868	Check Valve f/ K-Punch
001878	2.125" K-Set User Manual
001203	Force Gauge Assembly
002328	Redress Kit – K-Punch Hydraulic Actuator
002442	Redress Kit – K-Punch Head
000952	Surface Interface
001223	USB-A to Micro USB Interface Cable
001229	K-Log Software Application
001485	USB-A to USB-B Interface Cable