

SLICKLINE OPERATOR WORKBOOK

IMPORTANT NOTE:

1. Your point of reference to complete this workbook may be obtained from the following
 - Training Manual and any other training materials provided together with this workbook
 - Your Trainer, Assessor (Slickline Operator), Verifier (FSM) or senior colleagues
 - SOP / Quality Procedures & Processors
2. The completion of this Workbook is a joint effort and responsibility between you and your assessor therefore you have the obligation to request from your assessor to be assessed upon your completion of each topic
3. The completion of this Workbook is part of the MANDATORY requirements which you must fulfill to qualify for a promotion
4. Your training program is mostly self-driven, including this Workbook. It requires individual initiatives, dedication and commitment to complete the process.

NAME	ELDRIAN BIN JUIL
DATE OF JOIN	2 ND AUGUST 2021
CONTACT NO.	0138536077
RECEIVED DATE	6 TH MARCH 2023
DATE COMPLETED	20 TH MARCH 2024

B.1 OPERATIONS

Legend: C-Competent, NME-Need More Exposure

Document No.	PLAN FOR WELL SERVICES OPERATIONS	Assessment / Verification	Competency		Assessment Date
			C	NME	

FORM B 1.1	PLAN OPERATIONAL REQUIREMENTS				
	<u>CALCULATION & CONVERSION</u>				
	1. Convert to Decimal number i. $15/16'' = \underline{0.9375}$ ii. $1 \ 1/16'' = \underline{1.06}$				
	2. a) What is the conversion factor for the following i. 1 Meter = <u>3feet 28inches</u> feet ii. 1 PSI = <u>6.895</u> kpa iii. 1 Degree Centigrade = <u>33.8</u> Fahrenheit b) Base on your answer above (No 2), fill in the blank: i. $14 - \frac{3}{4}'' = \underline{0.37465}$ meter ii. 560 Bar = <u>56000</u> kpa iii. 450 F = <u>232.222</u> C				

3. Show how you utilize Gauge Vernier Caliper to measure OD or ID

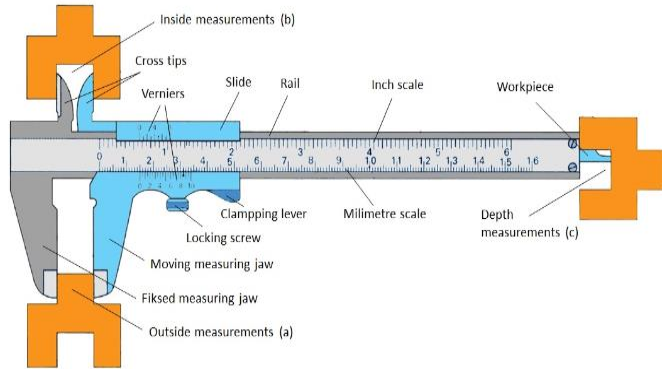

Vernier caliper

	<p>4. a) How many lbs/foot weight for the following wireline tools?</p> <p>i. 1 7/8 " Stem = <u>9.4</u> lbs/foot</p> <p>ii. 1 ½ " Stem = <u>6</u> lbs/foot</p> <p>iii. 1 ¼ " Stem = <u>4.2</u> lbs/foot</p> <p>b) Base on answer above, what is the weight for the following wireline tools</p> <p>i. 1 -7/8" x 5' Stem = <u>46.9</u> lbs</p> <p>ii. 1 ½ " x 3'Stem = <u>18.0</u> lbs</p> <p>iii. 1 ¼ " x 2' Stem = <u>8.4</u> lbs</p> <p>iv. 2 ½ " x 2' Stem = <u>33.3</u> lbs</p>				
	<p>5. Calculate how to get the answer for the following question</p> <p>i. 1 - 1/6" x 0.125" = <u>0.145833334</u> (in decimal number)</p> <p>ii. if 5x = 67, x equal to <u>13.4</u></p>				

	<p>6. Refer to the data below, what is the average hour/week employee at company A working?</p> <p>Sunday - 14 hours Monday - 12 hours Tuesday - 10 hours Wednesday - 16 hours Friday - 0 hour Saturday - 8 hours</p> <p>Answer: <u>60</u> hours/week</p>				
	<p>7. Write down the formula how to calculate for following items:</p> <p>i. Square Area = <u>WxH</u></p> <p>ii. Volume for square box and cylinder = <u>Force Area</u></p> <p>iii. Pressure = <u>0.052 x fluid density x true vertical depth</u></p> <p>iv. Force = <u>Mass x acceleration</u></p>				
	<p>8. Which is equal to 0.75? <u>i, ii & v.</u></p> <p>i. $\frac{3}{4}$ ii. $\frac{24}{32}$ iii. $\frac{5}{8}$ iv. $\frac{10}{16}$ v. $\frac{36}{48}$</p>				

FORM B 1.1	PLAN OPERATIONAL REQUIREMENTS			
	1. What is a 'PTW'? Are you aware a procedure on 'PTW' is in place? Name / Procedure Number / Locate Procedure <ul style="list-style-type: none"> • <u>PTW is permit to work system. Yes, I am aware of the procedure on PTW</u> 			
	2. Why do we need one for any wireline activity to take place on an offshore installation? <ul style="list-style-type: none"> • <u>We need PTW for wireline activity because our job scope is considered risky in nature, the work on each individual well must be covered by a PTW system and our work is in zone 2 area.</u> 			
	3. Explain the general process in applying for a permit-to-work for a wireline operation to take place. <ul style="list-style-type: none"> • <u>The general process in applying for a PTW for any wireline operation is:</u> <ul style="list-style-type: none"> - <u>Work hazards.</u> - <u>The location of the job.</u> - <u>Whether the job is cold or hot.</u> - <u>The well to be worked on.</u> - <u>Work to be done.</u> - <u>Sources of ignition.</u> - <u>Additional documents required like the JHA form.</u> <u>Clearance certificate form must be signed by Permit Applicant, Permit Coordinator, Permit Authoriser (OIM/DOIM), AGT (if gas test is required) and Permit Approver (WS/Senior OT)</u>			
	4. In the process of planning out an operation, you found out that some materials or special tools are not available on site. What will be your next course of action? <ul style="list-style-type: none"> - <u>It's shouldn't happen if you already plan ahead your task and receive next job plan by CSR. In case it happens, the best things you do is contact CSR at SJ-LQ and ask him to check inside our common file under SSPC surface equipment folder. At same time we can contact other location if they have the tools or those materials.</u> 			

	<p>5. Explain how you perform Pre & Post Job Check (Use Pre & Post Job Checklist)</p> <ul style="list-style-type: none"> - <u>The authorize personal or permit applicant shall apply for the PTW.</u> - <u>The OIM/WS shall sign as authorizing signatory after ensuring that the PTW are in order.</u> - <u>The OT onsite shall sign as approval signatory after considering that it is safe to proceed.</u> 				
	<ul style="list-style-type: none"> • When do you need to attend Briefing and De-briefing? • <u>Before mob to offshore and after de mob from offshore.</u> <p>What is the benefit of this session?</p> <ul style="list-style-type: none"> • <u>Define role and responsibilities before starting certain operations.</u> • <u>Know what is going to be done / prepared prior starting the operations.</u> • <u>Ensure procedures to be undertaken are understood.</u> • <u>Improved communication across all disciplines, practice improvement, Equipment, personnel and any HSE issues to be identified and addressed</u> 				
	<p>6. List down 5 important documents you need to bring offshore and why?</p> <ol style="list-style-type: none"> 1. <u>Safety passport.</u> 2. <u>Method of statement (MOS)</u> 2. <u>Fitness declaration form</u> 3. <u>Well Diagram</u> 4. <u>Inventory check list</u> 				

	<p>7. Explain your preparation before going offshore</p> <ul style="list-style-type: none"> - <u>Valid medical and courses</u> - <u>Completed and valid PPE.</u> - <u>Approved life jacket.</u> - <u>Physical fit</u> - <u>Mentally fit</u> 				
	<p>8. Describe your tasks upon arrival at the platform</p> <ul style="list-style-type: none"> - <u>Attend safety briefing by medic in-charge</u> - <u>Fill the health declaration form</u> - <u>Give the safety passport to medic</u> 				
	<p>9. List down tool string configuration prior to carry-out the following jobs:</p> <p>i. Tubing clearance <u>1 7/8 r/socket, 1 7/8" x 5' stem, 1.5" knuckle joint, 1 3/4" hydraulic jar, 17/8" x 20 stroke link jar, knuckle joint and quick connect.</u></p> <p>ii. Sinker Bar <u>1 1/4" r/socket, 1 1/4" swivel joint, 1 1/4" link jar, 1 1/4" knuckle joint 1 1/4"x 5' mellory.</u></p>				
	<p>10. Describe what the following terms mean:</p> <p>i. Insert Valve = <u>Safety valve</u></p> <p>ii. TRCSSV = <u>Tubing Retrieval Surface Control Subsurface Safety valve.</u></p> <p>iii. RIH = <u>Run in Hole</u></p> <p>iv. POOH = <u>Pull Out of Hole</u></p>				

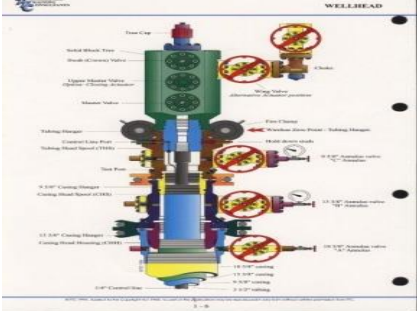
	<p>11. Draw the X-Mass Tree. Describe what is the function</p> <ul style="list-style-type: none"> The x'mas tree is a valve installed on the well head to control the flow of fluids from well 				
	<p>12. What is the valve fitted at X-Mass Tree? Which is the valve is always utilize during wireline operation?</p> <ol style="list-style-type: none"> Swab Valve / Crown valve. SSV / Actuator Lower master valve Wing Valve Flow line Valve <p>Swab valve is always utilize during wireline operation.</p>				
	<p>13. How many turns to close the Master Valve for the following x-Mass Tree:</p> <ol style="list-style-type: none"> WKM 2" (13 turns) 3" (19 turns) Ingram Cactus 2" (16 ½ turns) 3" (25 turns) Mcevoy 2" (12 ½ turns) 3" (18 ½ turns) 				

	14. Why is it compulsory to count when closing the Master Valve <u>To confirm no tool or wire across the swab valve prevent it from closing.</u>				
	15. Describe the process of installing pressure manifold at X-Mass Tree Tubing Hanger. <u>To monitor pressure buildup on the annulus.</u>				
	16. Describe the process prior to RIH and POOH tools string (example- to change wireline tools) <ul style="list-style-type: none"> • RIH =<u>Before run in hole all tool string connection need to recheck, tighten the connection if its loose. Make sure the tool string is correct.</u> • POOH=<u>Often check the pulling weight and make sure not to POOH very fast when passing any well accessories (possible tool will stuck and overpull).</u> 				
	17. Where to ZERO tool string prior RIH <ul style="list-style-type: none"> • <u>Tubing hanger</u> • <u>Rig floor for completion and work over job.</u> 				
	18. Why it is compulsory to carry-out pressure test upon completion of rig-up? Describe the process <ul style="list-style-type: none"> • <u>To confirm PCE integrity in good condition. (no leak during operation)</u> • <u>It's a safety measure in the oil and gas industry. This procedure helps ensure the integrity of the slickline equipment and prevents potential leaks or failure that could lead to dangerous situations, environment damage, or costly delays.</u> 				

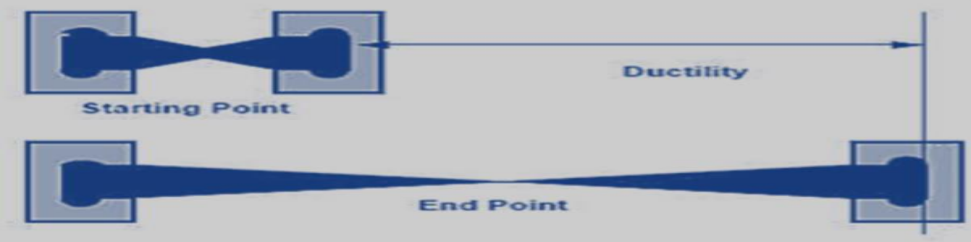
	<p>19. a) What is the breaking strength for the following wire?</p> <ul style="list-style-type: none"> i. 0.092" EIPS <u>1620 lbs.</u> ii. 0.108" EIPS <u>2125 lbs</u> iii. 0.125" EIPS <u>2700 lbs</u> <p>b) Describe the type and size of wireline utilize in Dimension Bid</p> <ul style="list-style-type: none"> • <u>0.108" Zeron</u> • <u>0.125" Zeron</u> • <u>0.140" Zeron</u> <p>c) What is the equipment to be used to carry out twist test? Show how to use it</p> <ul style="list-style-type: none"> • <u>Ductility Tester</u>  <p>d) Describe the maintenance required for the wire</p> <ul style="list-style-type: none"> • <u>Slickline wire requires care and maintenance to ensure that the slickline wire performance has not deteriorated heavily and ensure the longevity of the wire.</u> • <u>Must be greased at all times and wrapped in plastic wrapping.</u> 			
--	--	--	--	--

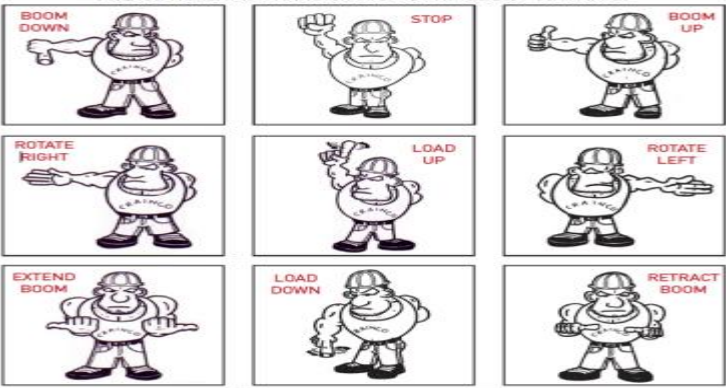
	<ul style="list-style-type: none"> • <u>Always lubricate the wire</u> 				
	<p>20. Show standard “HAND SIGNAL” for the following task:</p> <ol style="list-style-type: none"> Close the CV, MV and TRSCSSV For crane – Boom Up, Boom Down, Picking-up, Slack-off, Swing to right/left <div style="text-align: center;"> <p>CRANE HAND SIGNALS “SAFETY FIRST” <small>PLEASE HOLD YOUR HAND SIGNAL TO THE SIDE OF YOUR BODY</small></p>  </div>				
	<p>21. Describe the topic discussed in Pre-Job Safety Meeting</p> <ul style="list-style-type: none"> • <u>Muster station</u> • <u>Discuss the JHA</u> • <u>Job description so that all team members know their role and responsibilities.</u> • <u>Well condition.</u> 				
FORM B 1.2	SELECT AND TEST WELL SERVICES EQUIPMENT				

	<p>1. List the specific surface equipment needed for carrying out wireline work using 0.092"/0.108'/0.125'.</p> <ul style="list-style-type: none"> - <u>Specific equipment needed for carrying out wire line work is</u> - <u>Stuffing box, Lubricators, Dual Ram Hydraulic BOP, Wellhead adapter, Lubricator pup, X-over</u> - <u>Wire line power pack/reel skid with spool of wire, hydraulic hoses/pump and depth counter assembly</u> - <u>Gantry crane, Permanent gin pole, Hydraulic mast</u> - <u>Weight indicator, Hay pulley</u> - <u>SWCP</u> - <u>Lifting gears – chain block, slings, shackles, lubricator clamp</u> - <u>Pipe wrenches, manila rope for guide line, pressure gauges, hand off sign, needle valves, safety harness.</u> - <u>Only the hay pulley/stuffing box/wire clamp size is different:-</u> <p>1. <u>0.092 Wire Clamp – 9" Hay pulley - S/box with 8" sheave</u></p> <p>2. <u>0.108 Wire Clamp – 10" Hay pulley - S/box with 16" sheave</u></p> <p>3. <u>0.125 Wire Clamp- 12" Hay pulley - S/box with 18" sheave</u></p>				
--	---	--	--	--	--

2. Tabulate the standard toolstring for use in carrying out routine wireline operation.

JOBS	ROPE SOCKET	STEM	X-OVER	KNUCKLE JOINT	HYDRAULIC JAR	LINK JAR	QLS
RVC	1.7/8"	1.7/8" X 5'	-	-	-	1.7/8"	1.7/8"
GLVC/ZOC/ FBUS in 3.5" tubing	1.7/8"	1.7/8" X 5'	1.1/16" P X 15/16 B	1.5"	1.5"	1.5"	1.5'
GLVC/ZOC/FBUS in 2.7/8" tubing	1.5'	1.7/8" X 5'	-	1.5'	1.5'	1.5"	1.5'
GLVC/ZOC/ FBUS in 2.3/8" tubing	1.1/4"	1.1/4" X 6'	-	1.1/4'	1.1/4'	1.1/4"	1.1/4"

TOOLSTRING GUIDE FOR 7" GAS WELL

JOBS	ROPE SOCKET	STRETCH STIMULATOR	STEM	UPSTROKE JAR	LINK JAR	KNUCKLE JOINT
RVC	1.7/8"	2.5/8" X 1000 LBS	2.5/8" X 8'	2.1/8" X 800-1000 LBS	2.1/8"	-
PLUG OPS. SIDE POCKET VALVES	1.7/8"	-	1.7/8" X 8' OR 2.1/8" X 8'	1.7/8" OR 2.1/8" X 400- 600 LBS	1.7/8"	1.7/8"
SURVEY	1.7/8"	-	1.7/8" X 5' TUNGSTEN	-	1.7/8"	1.7/8"

	<p>3. Describe the procedure for checking the pulling and running tools for:-</p> <p>i. WR-SCSSV. <u>-Inspect tool fishing neck profiles for burrs and wrench damage.</u> <u>-Inspect all box and pin threads for damage & loose connections</u> <u>-Stimulate pulling tool on surface to ensure tool can release upon shearing of pin.</u> <u>-Check and ensure all connections in the tool are tight.</u> <u>-Check all tool parts are in good condition.</u> <u>-Ensure shear pins on running tool are flush-cut and rivet.</u> <u>-Ensure the appropriate equalizing prong is make up to the tool</u></p> <p>ii. KOT <u>-Inspect fishing neck profile for burrs and wrench damage.</u> <u>-Inspect pin threads for damage.</u> <u>-Check for slack in the arm joints and ensure arm pins are not loose.</u> <u>-Check finger springs are sufficiently strong to push the finger out at all times.</u> <u>-Check stiffness of arm assembly, if the arm springs are found to be weak, replace the arm springs.</u> <u>-Check condition of the set screw</u></p> <p>iii. GA-2 <u>-Ensure pin threads are in good condition.</u> <u>-Replace the 1/8' retaining roll pins if not in good condition.</u> <u>-Inspect plunger for any damage.</u></p> <p>iv. 1.1/4" JDC <u>-Check pin threads are in good condition</u> <u>-Ensure the dog spring is in good condition and the brazed ends are intact.</u> <u>-Check the dog shoulders are not worn.</u> <u>-Ensure the core extension is in place if pulling gas lift valves or dummy with integral bottom latch due to its long reach.</u> <u>-Stimulate tool on surface to ensure tool can release upon shearing of pin.</u></p>				
--	--	--	--	--	--

	<p>4. What is the minimum breaking load of:</p> <ul style="list-style-type: none"> i. Bridon UHT wire 0.092" - <u>1620 lbs</u> ii. Bridon UHT wire 0.108" - <u>2125 lbs</u> iii. Bridon UHT wire 0.125" - <u>2700 lbs</u> iv. 3/16" Galvanised Dyform wire – <u>3150 lbs.</u> v. Supa 70 wire size 0.108" – <u>1050lbs</u> vi. Supa 75 wire size 0.108" - 				
	<p>5. What is the recommended minimum sheave size for:</p> <ul style="list-style-type: none"> i. 0.092" – <u>11" inches</u> ii. 0.108" – <u>14" inches</u> iii. 0.125" – <u>16" inches</u> iv. 3/16" – <u>16" inches</u> <p>Rule of thumb: 100 times the Outside Diameter</p>				
	<p>6. Why is it important to check and clean the flame trap on the unit?</p> <p><u>To ensure that engine performance is not drastically impaired. Moreover, the safety of a diesel engine equipped with protective devices (flame trap) is dependent on the effective inspection and maintenance of the unit. Recommended interval by Well Services Workshop for cleaning the flame trap is every 8 running hours or daily after operation.</u></p>				
	<p>7. Why is it necessary to carry out torsion test or wrap test (as appropriate) on the wireline prior to a well entry work?</p> <ul style="list-style-type: none"> • <u>To check / ensure whether the wire is still in good condition and safe to be used.</u> • <u>To verified the integrity of the wire condition so as to prevent failure of wire down hole.</u> 				
	<p>8. What is the recommended distance separating the cell plates of the 0-2000 lbs range Martin Decker load cell assembly?</p> <p><u>7/16" to 1/2 "</u></p>				

	<p>9. Why do we need to maintain a minimum distance between the cell's plate and state what could happen if this distance is not maintain during the jarring operation?</p> <p><u>To provide for the accuracy of the indicated pull on the wireline. If the distance is not maintained during the jarring operation, the indicated pull will be much lower than the actual pull exerted on the wireline, and the possibility of parting the wireline may occurred.</u></p>				
	<p>10. Produce a checklist for the wireline reel skid prior to start-up</p> <ul style="list-style-type: none"> • <u>Check that the hand brake is on.</u> • <u>Check that operator's seat is secured.</u> • <u>Check that all guards are in place and secured.</u> • <u>Check that unit is properly anchored and no foreign object such as rags etc. are near the drum or the spooling head assembly.</u> • <u>Check that the wire is correctly fitted through the counter head assembly.</u> • <u>Check that the hydraulic hoses are properly connected.</u> • <u>Ensure four-way valves in neutral position.</u> • <u>Set two-way valves in open position.</u> • <u>Shift gear to neutral position.</u> • <u>Check the measuring head assembly.</u> • <u>Fully screw out anti clockwise the hydraulic pressure control valve.</u> 				
Form B 1.3	RIG UP WELL SERVICES EQUIPMENT				
	<p>1) Who authorizes and approves the PTW for Well Services activities? <u>Authorizer and approver.</u></p> <p>2) (SIMOPS/SIPROD) Simultaneous Drilling & Production Operations mode – <u>DOIM, PROCESS or WELL SERVICE SUPERVISOR</u></p> <p>3) Routine operations on a production platform – <u>OIM, WORK SUPERVISOR AND PROCESS SHIFT SUPERVISOR.</u></p>				

	<p>4) Why is it important to have a pre-job briefing/discussion before rigging up?</p> <ul style="list-style-type: none"> • <u>To make sure all crews involved in the operation are aware / know what are their roles and responsibilities in order to get the job done safely and successfully.</u> 				
	<p>5) What pre-checks are required prior to rigging up Well Services surface equipment? <u>Prior to rig up well services surface equipment, the following points taken;</u></p> <ul style="list-style-type: none"> • <u>Check for all equipment and tools on site.</u> • <u>Check for correct equipment for operation type.</u> • <u>Ensure lifting tackles are valid, W.H.E equipment testing date are not due.</u> • <u>Ensure worksite is safe for working</u> • <u>Function test equipment on surface, test run power pack and reel skid, open close BOP, and function test S.W.C.P.</u> 				
	<p>6) List down a standard lubricator configuration. Describe the sequence of assembling the lubricator followed by safe rigging up process.</p> <ul style="list-style-type: none"> - <u>Stuffing Box</u> - <u>Lubricator 8ft 3 section</u> - <u>QTS</u> - <u>BOP</u> - <u>Pump In Tee</u> - <u>Riser 8ft / 4 ft</u> - <u>Ball Valve</u> 				
	<p>7) Explain why is it important to position the BOP correctly?</p> <p><u>BOP should be positioned correctly because to ensure BOP can be closed and enough length of lubricator to accommodate the whole length of the tool string.</u></p>				
	<p>8) What is the acceptable gap range on the weight indicator load cell during zero check?</p> <p><u>The acceptable gap range on the weight indicator load cell during zero check is 7/16" to 1/2"</u></p>				

	<p>9) Wire running through the hay pulley of the weight indicator should be at what angle?</p> <ul style="list-style-type: none"> • <u>90 degree.</u> 				
	<p>10) Why is it important?</p> <ul style="list-style-type: none"> • <u>To get the correct weight reading from the weight indicator.</u> • <u>To ensure wire integrity is safe guarded.</u> • <u>Not to stress or fatigue the wire during running and pulling the tools out of hole.</u> 				
	<p>11) Give two reasons why you need to rig up the hay pulley correctly?</p> <ul style="list-style-type: none"> • <u>To reduce site loading.</u> • <u>To get a true reading on the weight indicator.</u> 				
	<p>12) Describe the process of BOP function and pressure testing for 0.092"/0.108" slick wire after rigging-up. Your answer should include how equalizing pressure across the closed BOP is done prior to opening the BOP rams. Under what circumstances do you need to operate the BOP?</p> <ul style="list-style-type: none"> • <u>After rig up, ensure BOP is fitted with blind rams which will match the .092" and .108" wire for pressure testing.</u> • <u>BOP can be closed manually or hydraulic driven hand pump or S.W.C.P.</u> • <u>Open swab valve slowly until pressure is fully equalize and open valve fully.</u> • <u>Close BOP rams fully and bleed pressure above BOP to zero and observe for any leak. If no leak open equalizing valve/screw so that pressure equalize across BOP slowly. After pressure fully equalize, tighten back the Allen screw valve on the equalizing valve and open rams fully.</u> • <u>The BOP rams are fitted with wire guide which will guide the .092" and .108" wire to the center of the BOP rams.</u> • <u>The closing of BOP is when well pressure need to be isolated without cutting the wire if master cannot be closed for tool string recovery or dropping of wire cutter.</u> 				

	13) With respect to wind direction, where do you position the wireline power pack in relation to the wireline winch? Why? <u>The wireline power pack should be position in the upwind direction because the operator will not inhale the smoke of the power pack.</u>				
	14) Why is it necessary to tie down the wireline winch after rigging-up? <u>This is to ensure the wireline winch is secured and anchored when encountering overpull, which may pull the winch toward the hay pulley if not secured.</u>				
	15) Why is it important to report remedial action taken on faulty equipment? <ul style="list-style-type: none"> • <u>To ensure the defective equipment not to be used for operation. The defective equipment must be repaired onsite or replaced and send back to workshop.</u> • <u>With this report we can determine the reliability of the equipment.</u> • <u>We can take measures to reduce production loss, equipment failure downtime.</u> 				
	16) How would you deal with defective equipment that is beyond repair on site? <ul style="list-style-type: none"> • <u>Report the issue verbally to CSR or Person in charge onsite.</u> • <u>Inform town and ask for the equipment replacement.</u> • <u>Raise the problem report and email to person in charge.</u> 				
	17) List down all Surface Equipment & Pressure Equipment required for rigging-up <ul style="list-style-type: none"> • <u>Reel skid unit.</u> • <u>Power pack.</u> • <u>Mast (if no gantry crane / gin pole on wireline deck)</u> • <u>Pressure control equipment. (riser, lubricator, BOP, QTS stuffing box)</u> • <u>Hydro test pump + Chart decoder</u> • <u>Drum water</u> • <u>Hay pulley</u> • <u>SWCP</u> • <u>OTS</u> 				

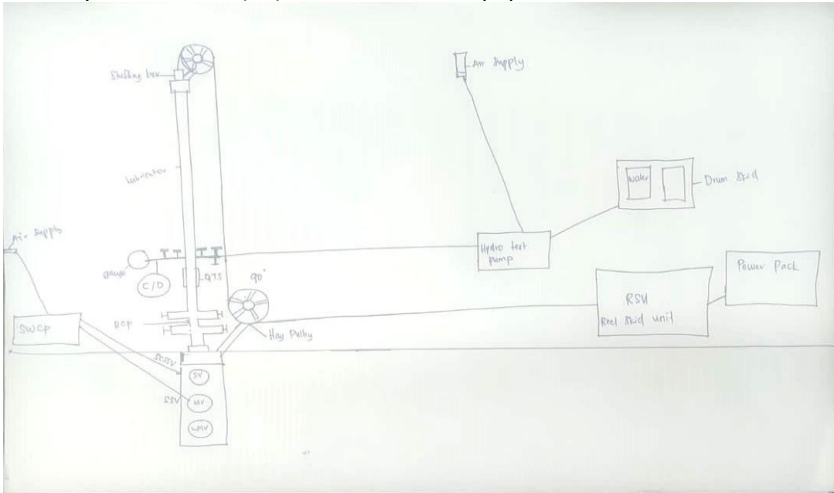
	<p>18) Draw lay-out for Item (17) and name each equipment</p> 				
	<p>19) Who would you seek advice and support with respect to:</p> <ul style="list-style-type: none"> • <u>Well Supervisor.</u> • <u>Field service manager.</u> • <u>Field engineer.</u> 				
	<p>20) Describe the process and safety pre-caution to be taken when opening Tree Cap Adaptor prior to rig-up</p> <ul style="list-style-type: none"> • <u>Performed leak test on the x-mas tree valves. SV & UMV.</u> • <u>Make sure there is no pressure trap.</u> 				
<p>RIG DOWN WELL SERVICES EQUIPMENT AND HAND BACK WELL</p>					

Form B 1.4	<p>1. What are the pre-check and sequence for safe rigging-down of lubricator?</p> <ul style="list-style-type: none"> • pre-job safety briefing is carried out. • barricade work area to control and to prevent third parties entering the area. • swab valve must be closed and lubricator depressurized to zero psi. • secured t/string with wire clamp. • remove pressure gauge and close BOP rams & dismantle BOP handles. • remove lubricator safety sling and undo lubricator union, lift lubricator with chain hoist and install thread protector at lubricator end. • Lower lubricator assy. With chain hoist. Secure guide lines at s/box and at lubricator end to control lubricator movement. • lay down lubricator assy. On lubricator rollers. Pick up riser from wellhead and install back x-mas tree cap. • install back hatch cover. • remove tool string inside lubricator, dismantle lubricator sections, bop & stuffing box and secure onto lubricator skid • carry out housekeeping at work area and at wellhead. 				
	<p>2) What would you do to ensure the wellhead area is clear before rigging-down?</p> <ul style="list-style-type: none"> • <u>Secure wellhead area by housekeeping the wellhead area and ensure the area is free from and obstruction.</u> • <u>Make sure kill wing valve, swab valve and upper muster valve are closed.</u> • <u>Make sure no pressure trap inside the lubricator (bleed pressure from the lubricator manifold)</u> • <u>Remove the hay pulley anchor.</u> 				
	<p>3) Explain why is it important to report any defective equipment and remedial action taken?</p> <ul style="list-style-type: none"> - <u>To ensure the defective is not to be used for operation. The defective equipment must be repaired onsite or replaced and send back to workshop.</u> - <u>With this report we can determine the reliability of the equipment.</u> - <u>We can take measures to reduce production loss, equipment failure downtime.</u> 				

	<p>4) It is necessary to hand back well to the frontline personnel to open up well as soon as possible after rigging-down. However, you may sometimes be requested to open up on their behalf. Why is it important to inform the frontline personnel before you open up the well?</p> <ul style="list-style-type: none"> - <u>They can make preparation on the production facility prior to the opening up of the well.</u> - <u>The frontline personnel would like to have wellhead pressure prior to the opening up of the well.</u> - <u>The frontline personnel want to know the well interruption for his daily report.</u> 				
	<p>5) How is the daily wireline operation report done in your area? Who need access to the report? For what purpose?</p> <ul style="list-style-type: none"> • <u>Daily report is done by the team leader (Wireline operator) every end of working day. In the report included:</u> <ul style="list-style-type: none"> - <u>Well number.</u> - <u>Wire balance (record and update if wire being discarded)</u> - <u>Engine running hours.</u> - <u>Validity of all equipment and slings.</u> - <u>Job type</u> - <u>Next activity / operation plan.</u> - <u>Number of wireline run/misrun.</u> - <u>Status of the well/history</u> - <u>Person involved in the operation.</u> • <u>The report needs to be accessed by the well Supervisor (CSR)</u> • <u>The report is essential to be presented and discuss research findings. Easy to find and updated when well history is needed.</u> 				
	<p>6) Under what circumstances that you have to rig-down the lubricator even though the job is not completed. Consider both oil and gas operations when answering.</p>				

Form B 1.5	DEMobilise AND STORE WELL SERVICES EQUIPMENT
------------	--

	<p>1. How would you prepare the following for:</p> <p>i) backloading</p> <ul style="list-style-type: none"> - <u>Prepare COG.</u> - <u>Check the validity and correct sling load.</u> - <u>Make sure the pad eyes and slings colour coding is updated.</u> - <u>Secure hoses, exhaust extension (if available) and loose item.</u> - <u>Remove martin Decker and hoses properly and secure onto reel skid.</u> - <u>Frame cover on p/pack to be installed.</u> - <u>Cover unit with canvas</u> <p>ii) storage on site :</p> <ul style="list-style-type: none"> - <u>Remove chair, secure properly martin Decker, dismantle hydraulic hoses & exhaust extension (if available)</u> - <u>Grease top section wire layer on reel skid.</u> - <u>Cover units with canvas and store/position units at safe and secure place.</u> 				
--	--	--	--	--	--

	<p>2. What are the pre-checks required for backloading with respect to lifting equipment, platform crane, sea and weather conditions?</p> <table border="1" style="margin-left: 20px;"> <thead> <tr> <th>Equipment</th> <th>Backloading</th> <th>Storage on site</th> </tr> </thead> <tbody> <tr> <td>Wireline units</td> <td>Prepare COG</td> <td>Grease wire</td> </tr> <tr> <td></td> <td>All sling still valid</td> <td>Cover unit with canvas</td> </tr> <tr> <td>Lubricators</td> <td>Install protector</td> <td>Service & oiled</td> </tr> <tr> <td></td> <td>Prepare COG</td> <td>Secured lubricator</td> </tr> <tr> <td></td> <td></td> <td>Put grease on the lubricator thread.</td> </tr> <tr> <td>Wireline tools</td> <td>Secure tools</td> <td>Inventory tool</td> </tr> <tr> <td></td> <td></td> <td>Service tools</td> </tr> <tr> <td></td> <td>Make sure tool box slings are valid.</td> <td>Store tool inside toolbox</td> </tr> </tbody> </table>	Equipment	Backloading	Storage on site	Wireline units	Prepare COG	Grease wire		All sling still valid	Cover unit with canvas	Lubricators	Install protector	Service & oiled		Prepare COG	Secured lubricator			Put grease on the lubricator thread.	Wireline tools	Secure tools	Inventory tool			Service tools		Make sure tool box slings are valid.	Store tool inside toolbox			
	Equipment	Backloading	Storage on site																												
	Wireline units	Prepare COG	Grease wire																												
	All sling still valid	Cover unit with canvas																													
Lubricators	Install protector	Service & oiled																													
	Prepare COG	Secured lubricator																													
		Put grease on the lubricator thread.																													
Wireline tools	Secure tools	Inventory tool																													
		Service tools																													
	Make sure tool box slings are valid.	Store tool inside toolbox																													
	<p>3. Explain why good housekeeping is necessary with respect to proper equipment storage.</p> <ul style="list-style-type: none"> • <u>To ensure equipment are safe and securely stored and maintained in good condition. Work area is safe and to prevent accident occur.</u> • <u>Save time to locate equipment and enable easy stock checking.</u> 																														
	<p>4. Why is it important to check equipment condition and update the equipment inventory for different locations regularly?</p> <ul style="list-style-type: none"> • <u>To ensure availability of equipment in each location is maintained and equipment are ready for next wireline operation.</u> • <u>To reduce downtime due to equipment failure.</u> 																														

	5. What is the essential information to be included on the consignment note for equipment returned to shore? <ul style="list-style-type: none"> • <u>Names and addresses of both consignor and consignee, details the goods and states who has the responsibility for insuring them while in transit.</u> 			
	6. For Third party equipment, what are the precautions to take during backloading and/or handling of hazardous materials? <ul style="list-style-type: none"> • <u>To have a toolbox meeting with personnel involves in backloading and handling.</u> • <u>Ensure what type of material so that special note/warning/hightlight is attached to the equipment.</u> • <u>The third party personnel should brief the personnel involves in the operation and must be onsite to supervise and instruct on the backloading/handling of hazardous materials.</u> 			

Assessed By:		Verified By	
Name		Name	
Position		Position	
Date		Date	