

Title	Break Out Project				
Target Population	Field Engineers & Field Specialists				
This requirement is applicable to:	✓	JFE	✓	FST	EOT
	✓	FE1	✓	FS1	EO1
	✓	FE2	✓	FS2	EO2
			✓	FS3	EO3
					✓ GEO

Objective:

The objectives of this task are:

- To assess the employee’s ability in applying critical thinking and problem solving
- To assess the employee’s communication and organizational skills
- To assess the employee’s technical, QHSE and management skills
- To assess the employee’s ability in the entire DEE cycle; data collection & analysis, complete stages of job executions and job evaluations.
- Create an opportunity for the FE and FS to improve his presentation skills by practicing with a large and critical audience.

Tasks:

- Select an operational subject for the project and obtain approval from respective the Mentor and FSM. Mentoring and management supervision is essential in this technical exercise.
- For FE; collect and analyze all data required to do a complete design of the operation including all applicable Cerberus modules.
- Get involved in the pre-job preparations ie. all resources needed for the operations (personnel, and equipment).
- As the second supervisor on site, the FE / FS is expected to supervise and record the job execution therefore he needs to have a complete understanding of the operation.
- For the FE, prepare a technical evaluation of the actual operation design against the actual job. During this stage the FE must calibrate the job parameters for the upcoming operations (friction coefficient, fluid friction table, fluid rheology, additives concentrations, etc.).
- Prepare a technical presentation (up to 20 slides) supported by a detailed document in SPE paper format (4 pages min); taking into consideration all technical and operational aspects related to the project.
- Finalize the project and present to Line Management and technical team (Operation Engineer). You will have 20 minutes for presentation and 30 minutes for question and answer session.

Notes:

- Project scope: the project is to be based on Coiled Tubing operation - Standard or Advanced services application. The evaluation is focusing on the employee's understanding on technical and operational process and his ability to apply them in the project.
- The FE/FS must be fully involved in the DEE cycle.
- The project should provide detail of all technical tools and/or software used to develop it.

REQUIRED EVIDENCE:

- 1 Slide Presentation
- 2 CTS-FORM-84 CTS Improvement Project Abstract Template
- 3 CTS-FORM-85 SQIP/Breakout Project Evaluation Form
- 4 Attendance Form

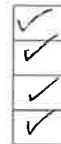

<p>MENTOR / ASSESSOR's Comments & Recommendation:</p> <p style="text-align: center;"><i>Objective met. Tasks completed.</i></p>			
Signature	<i>[Signature]</i>	Assessment Date	<i>15/10/24</i>
Name	<i>KUNG YEE HAN</i>	Position	<i>TECH ADVISOR</i>

<p>FSM / OM Comments & Recommendation:</p> <p><i>Task completed.</i></p>			
Signature	<i>[Signature]</i>	Assessment Date	<i>15/10/24</i>
Name	<i>RIDWAN AZIZAN</i>	Position	<i>FSM</i>

DIMENSION BID

SQIP/BREAKOUT PROJECT EVALUATION FORM

COILED TUBING SERVICES

PERSONNEL DETAILS

FULL NAME

Muhammad Hafiz Saharuddin

POSITION

Field Engineer 2

PROJECT NAME

Long Deployment BHA inside Casing section through Short string

PROJECT FOCUS LEVEL

Design and execution

DATE OF PROJECT APPROVAL

15/10/2024

PROJECT OVERALL SCORE

90%

DATE OF PROJECT PRESENTATION

15/10/2024

PROMOTION STEP

FE2 to GFE

Rating (Please ✓ where appropriate)

EVALUATION CRITERIA

STRONG

ADEQUATE

IMPROVEMENT NEEDED

COMMENTS

10 9 8 7 6 5 4 3 2

PROJECT PRESENTATION

1 Audibility & Speech

2 Clarity & Organization

3 Visual Presentation

4 Hand-outs/Publication

PROJECT EVALUATION

1 Project Objectives

2 Project Implementation

3 Costing Beneficial

4 Project Impact on DB

5 Project Impact on Client

6 Continuous Monitoring and Improvement

OTHERS

1 Proposal

2 Project Communication

3 Risk Control

4 Resources Management

PROJECT EVALUATOR

Task completed

CANDIDATE'S SIGNATURE

INSTRUCTOR'S SIGNATURE

MANAGER'S SIGNATURE

DATE



 15/10/24



15/10/24







ATTENDANCE FORM

Purpose: Meeting Training / Seminar / Workshop

Type of Training: Classroom Practical / Hands On Technical Sharing

Training Facilitator / Trainer: Hafiz .

Topic/Subject	SQIP / Breakout Project – Hafiz	Date	15/10/2024
Venue	BK office .	Time	
Meeting Coordinator	Hafiz	Meeting/ Training Duration	

No.	Name	Position	Signature
1	Hafiz .	FE 2 .	
2	Faizal ALI	SOE	
3	KUNG YEE HAN	TA.	
4	FIDHWAN AZIZAN	FSM	
5	ShahFARIZ	FE	
6	Zaem	FE	
7			
8			
9			
10			
12			
13			
14			
15			

Remark / Comment

DIMENSION BID

This project proposal is prepared for the CTS Development Plan (CTS Improvement Project)

Clean-out inside casing through short string Long Deployment BHA to avoid risk of stuck inside Casing Section

Muhammad Hafiz, CTS, Kemaman
14/10/2024

Abstract

Coiled Tubing (CT) cleanout is a standard procedure performed after a well has been producing for a certain period. Typically, sand accumulation inside the tubing can be cleaned without significant issues when the proper techniques are applied. However, when sand accumulates and restricts reservoir flow or pressure at the perforation interval within the casing or tubing section, a more focused intervention may be needed. To help restore production, a CTU sand cleanout can be performed to remove the sand that has buried the perforation tunnel. In single-string well completions, cleanout operations involving CT strings exiting the tubing usually proceed without complications. However, in multiple-string completions—especially when focusing on the short string—cleanout operations outside the casing become more complex and riskier due to the potential for the CT string to become entangled with the tubing in long-string completions.

Introduction

In line with the abstract, performing Coiled Tubing (CT) cleanout inside the short string, specifically outside the casing section, is typically avoided by many service providers due to the high risk of the CT becoming entangled with the production tubing in the long string. This risk can lead to the CT string and the bottom hole assembly (BHA) being lost inside the casing. Furthermore, if the CT string becomes entangled with the production tubing, the chances of successfully dropping a ball to disconnect at the mechanical head assembly (MHA) are low. This situation would then require the mobilization of additional external or internal cutters to sever the CT string, resulting in additional costs for the client, including standby charges while waiting for the cutter to be delivered offshore—making the operation economically unviable.

Sand accumulation inside the casing is a routine issue faced by clients and has a high potential for recurrence in other wells or fields. To ensure higher success rates for sand cleanout (SCO) operations and to reduce the risk of CT getting stuck during cleanout, this proposal has been developed to meet client objectives effectively. CT strings tend to bend, especially after exiting the End of Tubing (EOT), due to reduced restriction from the tubing wall. This bending can cause the CT string to shift

towards a horizontal trajectory, leading to entanglement with the long string completion.

In 2020, DB conducted a CT cleanout through the short string inside the casing section. During the operation, the CT string encountered several issues, including high pulling weight, which indicated that it had likely entangled with the long string. Fortunately, after multiple cycles of reciprocation and overpull over four hours, the CT string was eventually released.

The main idea behind this proposal is to ensure that the lower BHA remains as stiff as possible to guide the CT string downward in a vertical direction towards the perforation interval. It would be best to prevent MHA from exiting the EOT. Using a long, straight bar BHA can help reach the target depth of the perforation interval. In the event of a CT string becoming stuck during the operation, the ability to drop a ball to release the CT from the MHA without deploying additional resources (e.g., external/internal cutters) can significantly reduce standby and mobilization costs for the client.

Problem Definition

To prevent the CT from becoming entangled with the long string in the casing section and to avoid unable to release the CT string in event of CT stuck happen, a long BHA setup is proposed. This will ensure that the BHA remains as stiff as possible, preventing the mechanical head assembly (MHA) from exiting the End of Tubing (EOT). If the distance from the EOT to the perforation tunnel is significant, a longer BHA is needed to ensure the nozzle reaches the target depth. However, there are limitations to deploying a long BHA, such as the main deck height and jacking frame height. To overcome these challenges and proceed with the operation, a specialized deployment package is required for deploying the long BHA into the well.

Benefit to Dimension Bid and to Client

As outlined in the introduction, this project will enable the client to regain production by removing accumulated sand in the casing section, which will result in increased production rates. By reducing the risk of the CT string becoming stuck inside the well, the need to mobilize a cutter to sever the CT string in the event of a release failure is minimized, thus avoiding additional costs. This, in turn, secures a steady stream of work for Dimension Bid, helping to sustain operations at the client's facilities. Moreover, preventing the CT string—especially new strings—from getting stuck and left in the well eliminates the need for Dimension Bid to purchase new strings, allowing the company to continue its operations efficiently at other locations

Project Objectives

The objective of this proposal is to reduce the risk of Coiled Tubing (CT) becoming stuck during interventions inside the short string within the casing section. By minimizing this risk, the company can ensure a continuous stream of potential jobs from

DIMENSION BID

the client, maintaining long-term collaboration and operational efficiency.



Project Deliverables, Resources and timelines

The project is expected to be executed within three weeks of receiving notice from the client, with support from the PCE in Package #3 for the deployment setup. If the PCE is unavailable, outsourcing to another company, such as Dimension Bid's technical partner, Schlumberger (referencing the Angsi A-25 case study), would be necessary. The additional BHA required for the job includes the straight bars needed to reach the target depth (perforation interval). This requirement can be fulfilled by either renting from another downhole tool service provider or manufacturing through a local fabrication company, with a lead time of less than two weeks. As per the contract with PCSB, the additional cost for the deployment setup is MYR 293,400 per month.

Conclusion

This project will greatly benefit the company by reducing the risk of Coiled Tubing (CT) becoming stuck or entangled, ensuring successful release during interventions inside the casing section through the short string, particularly for cleanout operations. By mitigating these risks, the project will help build client trust, encouraging continued collaboration and future interventions. This, in turn, will contribute to increased revenue for Dimension Bid.

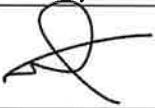
**This proposal should be kept to a maximum of 6 pages.
Any supporting documentation should be attached in the abstract**

	Prepared and Submitted By:	Verified By:	Approved By:
Sign:			
Name:	Muhammad Hafiz Saharuddin	KUMF YEE HAN	RIDHWAN A ZULHAN
Position:	Field Engineer 2	TECH ADVISOR	PSM
Date:	14 th October 2024	15/10/24	15/10/24

BREAKOUT PROJECT / SQIP PRESENTATION DULANG B07S SAND CLEANOUT

Table of content:

- Introduction & well overview
- Well overview : well diagram, background info

- Job Execution
- Equipment layout, P&ID and well stack-up
- Volume calculation
- Execution summary and plan
- Decision tree
- TFA & cleanout simulation

P&ID – CTU cleanout

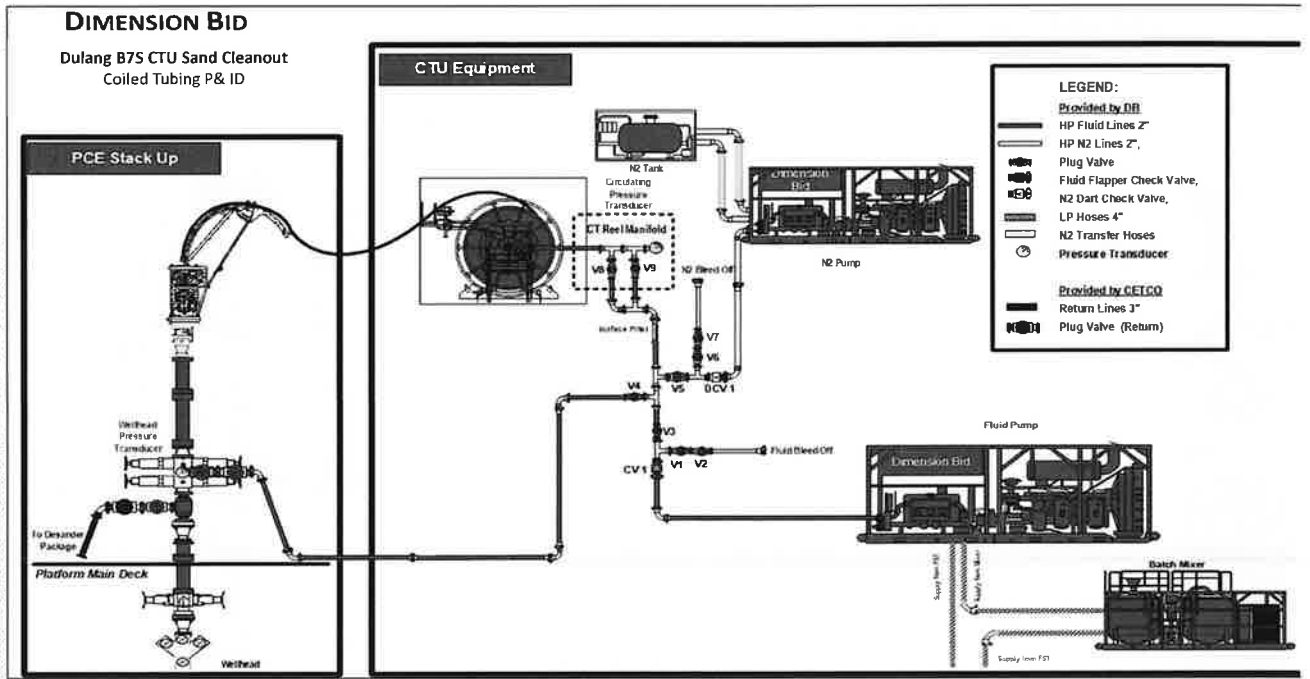

P&ID – CTU cleanout

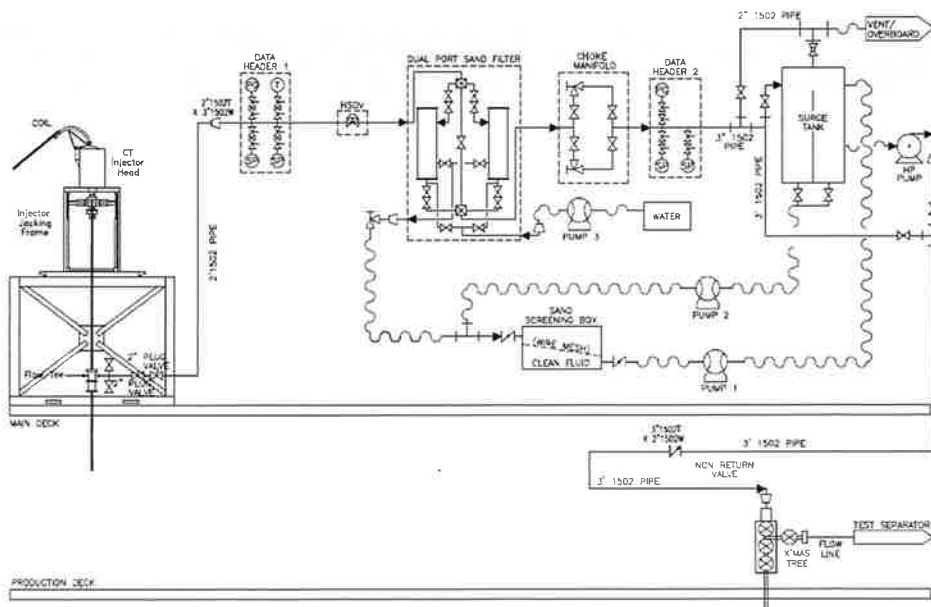

Well stack-up

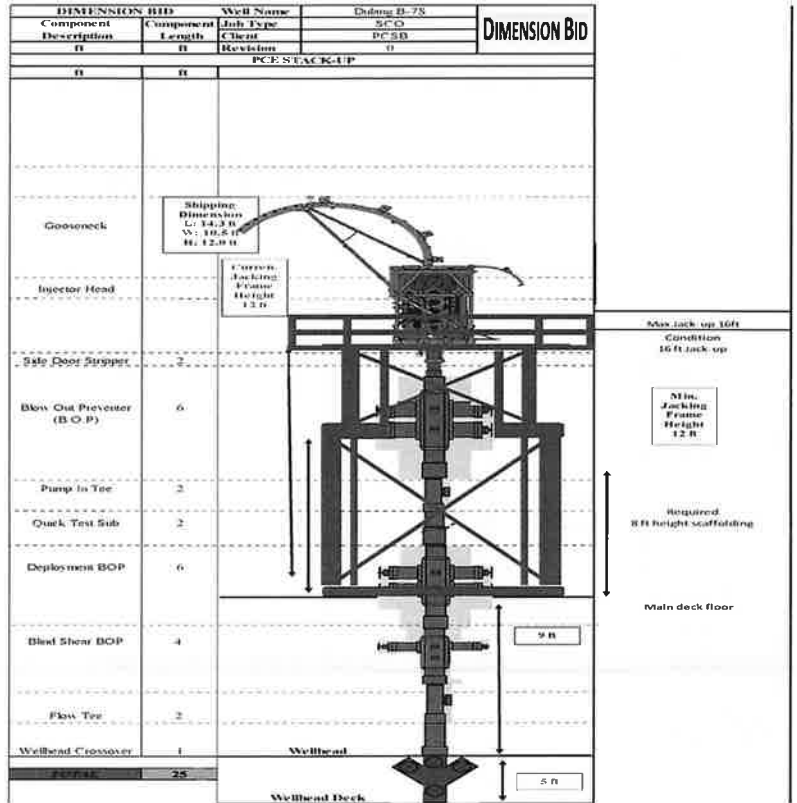

Volume calculation

Type	External Pipe			Internal Pipe 1			Internal Pipe 2			Csg	From	To	From	To	Length	Total Volume (bbl)
	OD (inch)	ID (inch)	Wt (lb/ft)	OD (inch)	ID (inch)	Wt (lb/ft)	OD (inch)	ID (inch)	Wt (lb/ft)							
Tubing volume until EOT	2 7/8	2.441								0.00579	0	1,514	0	4,967	4,967	28.75
Wellbore volume	9 5/8	8.835		2 7/8						0.07582	1,510	1,558	4,954	5,112	157	11.94
PCP volume	9 5/8	8.835		2 7/8			2 7/8			0.05977	0	1,510	0	4,954	4,954	296.10

String details

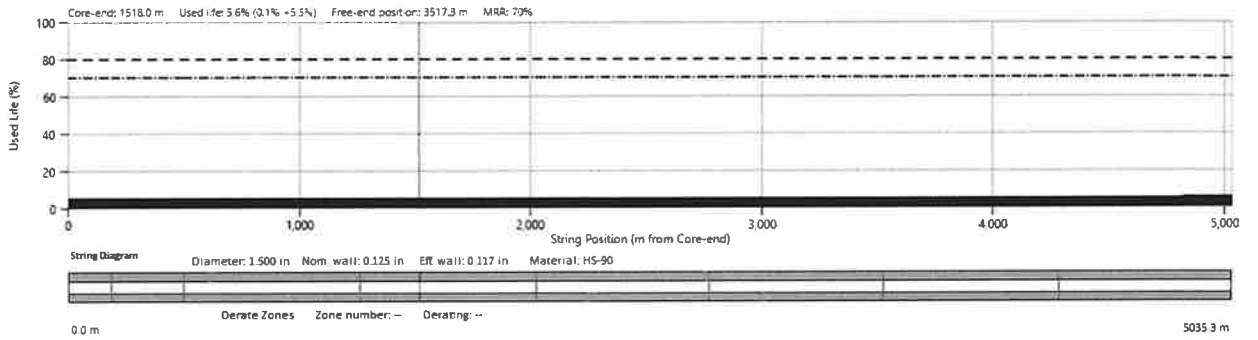

String details

CT String Details

String	#40423
Manufacturer	TENARIS
ID	1.5
Grade	HS 90
Initial Spooled Length, ft	16,520
Cable (lengthID Num)	
Weld Type	BIAS WELD
Tubing Weight	30399lbs
Commission Date	18-Apr-23

Run #	Date	Client	Field	Well	Job	CT leng ft	Job Fatigue %	Job Corrosion %	Cum Fatigue	Cum. Corrosion	Used String Life
		Name	Name	Num	Type				%	%	%
	15/7/2023	PCSB	OPEN YARD	NA	Received CT String from Manufacturer	16520	0	0	0	0	0
	1/9/2023	PCSB	OPEN YARD	NA	1 Month storage at Open yard	16,520	0	0.5	0	0.5	0.5
	1/10/2023	PCSB	OPEN YARD	NA	1 Month storage at Open yard	16,520	0	0.5	0	1	1
	1-Nov-23	PCSB	OPEN YARD	NA	1 Month storage at Open yard	16,520	0	0.5	0	1.5	1.5
	1-Dec-23	PCSB	OPEN YARD	NA	1 Month storage at Open yard	16,520	0	0.5	0	2	2
	1-Jan-24	PCSB	OPEN YARD	NA	1 Month storage at Open yard	16,520	0	0.5	0	2.5	2.5
	1-Feb-24	PCSB	OPEN YARD	NA	1 Month storage at Open yard	16,520	0	0.5	0	3	3
	1-Mar-24	PCSB	OPEN YARD	NA	1 Month storage at Open yard	16,520	0	0.5	0	3.5	3.5
	1-Apr-24	PCSB	OPEN YARD	NA	1 Month storage at Open yard	16,520	0	0.5	0	4	4
	1-May-24	PCSB	OPEN YARD	NA	1 Month storage at Open yard	16,520	0	0.5	0	4.5	4.5
	1-Jun-24	PCSB	OPEN YARD	NA	1 Month storage at Open yard	16,520	0	0.5	0	5	5
	13-Jul-24	PCSB	OPEN YARD	NA	SPOOLING INTO CTR DRUM	16,520	0	0.5	0	5.5	5.5
	14-Jul-24	PCSB	OPEN YARD	NA	DROB BALL/MAKE UPIPTIC/PURGE	16,513	0	0	0	5.5	5.5

Job execution summary

Operation	Job summary
Slickline operation	1. TCC (depends on client job execution plan)
CT operation	1. Sand cleanout from EOT(1,514 m) until 17 m below perforation zone (1,545m)
Slickline operation	1. TCC (depends on client job execution plan)

11

Job execution plan – Deployment BOP

- Run#1 – Sand cleanout from EOT at 1,514m until 1,545m using multi-jet nozzle;
1. Make up BHA consist of the following tool:

First section

#	Description (OPTION 1 BHA)	OD _(max)	Length ft	Length m
1	End connector: Internal dimple	1.69"	0.3	0.1
2	Motorhead assembly (MHA)	1.69"	2.3	0.7
3	Carsac	1.69"	1.6	0.49
4	Kelly Cock Valve	1.69"	1.6	0.49
5	Deployment bar	1.5"	6	1.83
6	Straight Bar	1.69"	90	27.4
7	Multi jet nozzle	1.69"	1.0	0.3
Cumulative Length			102.8	32.61

2. Refer to next slide for Rig-up/rig-down procedure

12

Job execution plan – Deployment BOP

➤ Run#1 – Continue..

- After perform pressure test stack-up, break off at QTS as per diagram below

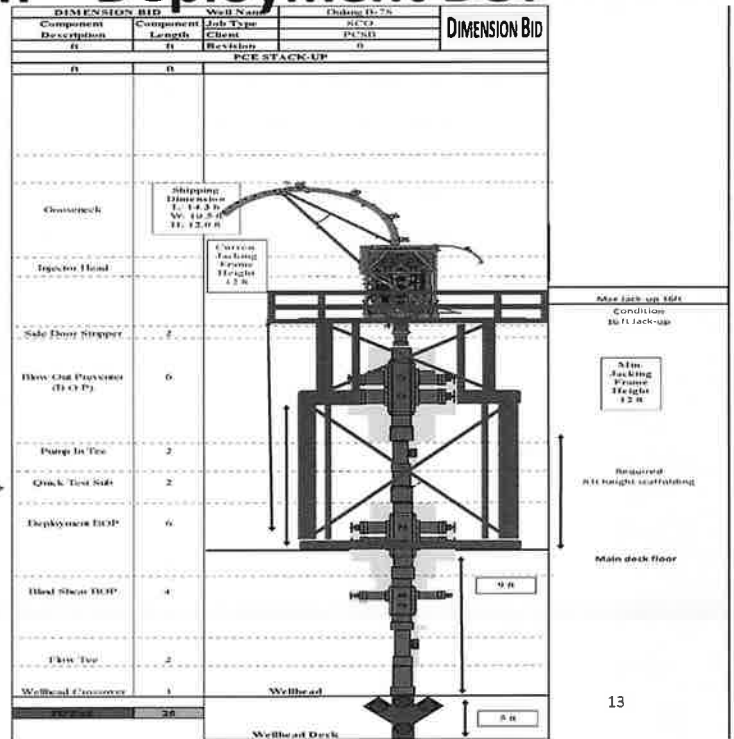
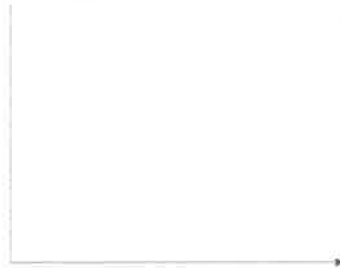

Job execution plan – Deployment BOP

➤ Run#1 – Continue..

- After skid out from B-7S, place the CT PCE stack up into other well slot by opening the hatch cover in order to hang the riser (below main deck) temporarily

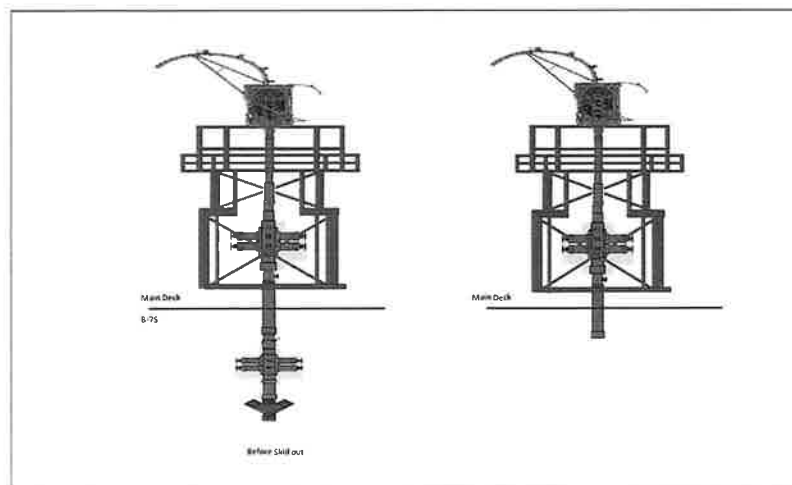

Job execution plan – Deployment BOP (option 1)

➤ Run#1 – Continue..(Note, total lubricator height subject to discussion with slickline)

- Make-up slickline lubricator on top of Lower QTS
- Deploy the BHA using Slickline
- Slowly RIH and open well, once the first deployment bar section at Deployment BOP, stop RIH

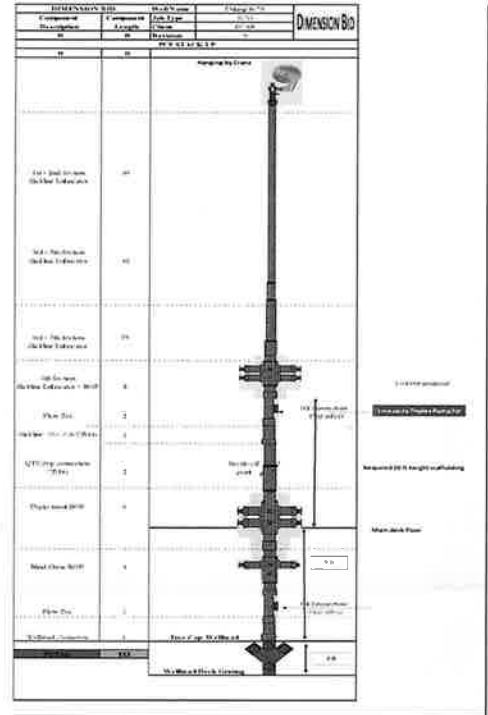

Job execution plan – Deployment BOP (option 1)

➤ Run#1 – Continue..

- Active deployment BOP to anchor and hold at deployment bar.
- Break-off at QTS, rig-down slickline PCE, and rig up full CTU stack-up.
- Connect MHA with the Carsac, and Open Kelly cock valve on BHA section.
- Perform pressure test at QTS.

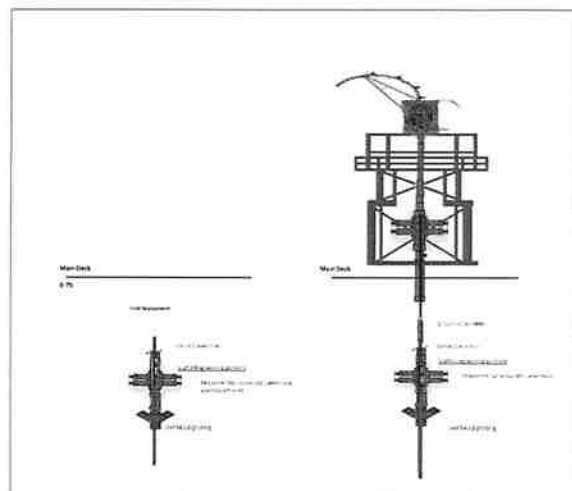

Rig-up procedure with barrier (Option 1)

No.	Job step	Primary / Active barrier	Secondary Barrier	Tertiary Barrier
1.	Disconnect at slickline crossover that attached together with QTS	1. Crown Valve 2. Master Valve 3. SCSSV 4. SSV	1. SBOP (Blind/shear)	
2.	Make-up 100 ft BHA consist of Nozzle, Straight bar, DKCV and Carsac. Swallow all first section BHA into slickline lubricator.	1. Crown Valve 2. Master Valve 3. SCSSV 4. SSV	1. SBOP (Blind/shear)	
3.	Box in and connect slickline XO and flow tee into top QTS XO to slickline PCE. Perform pressure test.	1. Crown Valve 2. Master Valve 3. SCSSV 4. SSV	1. SBOP (Blind/shear)	
4.	Open CV and MV, RIH until deployment Bar at Deployment BOP section	1. SCSSV 2. DKCV 3. Stuffing box - Slickline	1. SBOP (Blind/shear)	
5.	Engage deployment BOP to hold deployment bar in first section BHA	1. SCSSV 2. DKCV 3. Stuffing box - Slickline	1. SBOP (Blind/shear)	
6.	Disconnect at slickline crossover	1. SCSSV 2. DKCV 3. Deployment BOP (Dual Pipe/slip ram)	1. SBOP (Blind/shear)	

17

Rig-up procedure with barrier (Option 1)

No.	Job step	Primary / Active barrier	Secondary Barrier	Tertiary Barrier
7.	Rig-up CT PCE on top of QTS	1. SCSSV 2. DKCV 3. Deployment BOP (Dual Pipe/slip ram)	1. SBOP (Blind/shear)	
8.	Make-up CT connector and MHA	1. SCSSV 2. DKCV 3. Deployment BOP (Dual Pipe/slip ram)	1. SBOP (Blind/shear)	
9.	RIH MHA and connect to the Carsac at first deployment BHA section	1. SCSSV 2. DKCV 3. Deployment BOP (Dual Pipe/slip ram)	1. SBOP (Blind/shear)	
10.	Open DKCV and Box-in to connect PCE, perform pressure test stack-up	1. SCSSV 2. Deployment BOP (Dual Pipe/slip ram) 3. Stripper	1. SBOP (Blind/shear)	
11.	Disengage deployment BOP	1. SCSSV 2. Stripper	1. SBOP (Blind/shear) 2. COMBI BOP (Pipe/Slip) + (Blind/Shear)	
12.	Start RIH	1. Stripper	1. SBOP (Blind/shear) 2. COMBI BOP (Pipe/Slip) + (Blind/Shear)	

18

Job execution plan – Deployment BOP (option 1)

➤ Reverse deployment method

- a. Once CT at surface, proceed for reverse deployment for dummy/Gun using same approach during deployment rig-up.
- b. Once CT tag stripper, RIH back slowly until deployment bar at deployment BOP
- c. Cross the pipe slips ram, of the deployment BOP, Manually lock it.
- d. Bleed the remaining pressure inside riser through flowback line.
- e. Close the DKCV
- f. Secure the 1st section BHA with C- plate and disconnect at Carsac connection.
- g. Skid aside injector head, stripper, combi BOP and riser.
- h. Rig- up back the lubricator as per agreed with slickline (Geowell)
- i. RIH slickline wire and connect at Carsac connection. Remove the C-Plate.
- j. Box-in and pressure test at QTS.
- k. Open pipe slip/ram of the deployment BOP
- l. POOH until tag stuffing box
- m. Secure the well.
- n. Break-off QTS connection and retrieve the gun.

19

Job execution plan

➤ Run#1 – Continue..

3. Open up well and start RIH (pump idle rate TSW / IW (Fluid selection subject to client Approval)) until reaching 10m above EOT at depth 1,514m. Slow down coil speed to 10ft/min, 50ft before and after passing through completion accessories.
4. Perform pull test and pump 2bbls of drag reducer for every 1000ft interval .
5. At EOT, increase pump rate to **1.1bpm with 300scfm** nitrified TSW/IW. Establish return at surface first prior to entering the casing section and to penetrate the HUD.
 - During establishing the return at surface, line up the flowback line to surge tank and monitor the return volume and calculate the flowrate. (bbl/min)
 - If unable to establish the return, stop pumping N2 and continue to fill up tubing + wellbore and re-attempt to establish the circulation with nitrified TSW / IW
 - Mark the flowrate as baseline and fill up the additional flowback data monitoring table

20

Job execution plan

➤ Run#1 – Continue..

5. Penetrate the HUD with 1ft/min as per CIRCA simulation. Monitor the THP, return and RIH weight. (Start Cleanout from EOT, assume Sand at EOT)
6. Circulate 5 bbls of gel (D801) for every 5 m penetration. Perform pull test 5ft/min to previous HUD for each bite taken. Repeat the step until 1,545m .
7. *Note: after every 5m bite, pull test to EOT as a precautionary steps.*
8. In the event of lost return, POOH CT to 10m above EOT at depth 1,505m and re-establish the circulation before resume the cleanout
9. Once at 1,545m, flag coil at surface as Flag#1. Do not set down more than 200lbf if experience hard tag. (downhole force)
10. Pump 30 bbl of gel and continue CBU for 3 hours as per CIRCA. To perform pull test 10m for every 30 minutes.
11. Once completed CBU, POOH to EOT at depth 1,545m with 5 ft/min of tripping speed and using pump rate 1.1bpm, 300scfm.
12. At EOT, CBU for another 2 hours, continue to POOH to surface with 30-50ft/min of tripping speed, stop N2 and continue pumping TSW with 1.4bpm.

21

Job execution plan

➤ Cleanout table until 1,545m

No.	Stage	Fluid	Liquid Rate	Total Liquid	N2 Rate	CT Speed	Duration	Depth	Remarks
			BPM	BBL	SCFM	ft/min	Minute	m	
1	CT at 10m above EOT	TSW / IW	1.1	16.5	300	0	15	10m above EOT	Establish return on surface
2	RIH to HUD and Penetrate HUD/Fill	TSW / IW	1.1	17.6	300	1	16	HUD + 5m	Monitor return & CT weight on surface
3	Circulate	Gel	1.1	5.0	300	0	5		Provide suspension to the fill and lift to surface
Pull Test to EOT after 5m bites									
4	RIH to last HUD and Penetrate HUD/Fill	TSW / IW	1.1	17.6	300	1	30	HUD + 5m	Monitor return & CT weight on surface
5	Circulate	Gel	1.1	5.0	300	0	5		Provide suspension to the fill and lift to surface
Pull Test to previous HUD									
Repeat above step until reached 1,545m. Flag CT at surface.									
6	At depth 1,545 m	Gel	1.1	30	300	0		Stationary at 3160m	Pump 1tbg volume of D801 gel
7	Bottoms Up (Circulate)	TSW / IW	1.1		300	0	180	Stationary at 3160m	CBU remaining 3 hrs
POOH to EOT while maintaining 5 ft/min and pump rate 1.1bpm, 300scfm, Continue CBU for another 2 hours									
stop N2, continue POOH to surface with 30-50ft/min tripping speed by pumping high rate TSW / IW only									

22

Loss return scenario

1. Procedure for loss return during cleanout operation;
 - Pick-up CT to less deviated section at range of 400m or attempt at 10m above EOT.
 - Re-establish the circulation until stable return is observed.
 - During establishing the return at surface, line up the flowback line to surge tank and monitor the return volume and calculate the flowrate. (bbl/min)
 - Mark the flowrate as our new baseline and fill up the flowback data monitoring as per below table;

CTS FLOWBACK DATA LOGSHEET									
Job Type	Date		Well Details		DIMENSION BID				
Well No.	Location		Well						
Time	Flow Rate (bbl/min)	Pressure (psi)	THP (psi)	Flow Rate (GPM)	Choke Size	Return Volume (bbl)	Surge Tank	Remarks	Operator

- RIH back to last penetrated HUD and resume cleanout operation.

Reduction in THP during cleanout

1. Procedure for addressing the reduction in THP during cleanout operation:
 - Pick-up CT 10m above 1st HUD
 - Vary the;
 - Decrease the liquid rate
 - Increase nitrogen rate
 - Manipulate choke size
 - Re-establish continuous return and stable THP
 - Resume cleanout operation

Job execution plan

➤ Run#1 – BHA Diagram – Deployment

DIMENSION BID

BHA DIAGRAM #1 – 1.69" MULTIJET NOZZLE

Client:	Petronas Carigali
Field:	Dulang Bravo
Job Type:	
Job No.:	Run#1

Well:	D75
BHA Restriction:	
BSP:	
BIT:	

BHA DRAWING	DESCRIPTION	CONNECTION		ID	OO	TOOL LENGTH		CUMULATIVE LENGTH	
		UPHOLE	DOWNHOLE			INCH	FT	INCH	FT
	Dimple Connector	1 5" CT	1 0" AMMT PIN		1.680	0.3	0.3		
	MHA Disconnect drop ball 5/8"	1 0" AMMT BOX	1 0" AMMT PIN		1.680	2.3	2.6		
	Circulating drop ball 1/2"								
	Burst Disc 5000 psi								
	Carsac	1 0" AMMT BOX	1 0" AMMT PIN		1.680	1.8	4.18		
	Kelly Cock Valve	1 0" AMMT BOX	1 0" AMMT PIN		1.680	1.8	5.76		
	8 ft Deployment Bar	1 0" AMMT BOX	1 0" AMMT PIN		1.500	8.0	11.76		
	Straight Bar	1 0" AMMT BOX	1 0" AMMT PIN		1.680	62.0	103.76		
	Multi-Jet	1 0" AMMT BOX			1.680	1.0	104.8		
							BHA LENGTH:	104.76	
						MAXIMUM O.D.:	1.69		
						MINIMUM I.D.:			

Tubing force analysis-well geometry

A1 The job can probably be performed with the current input parameters.

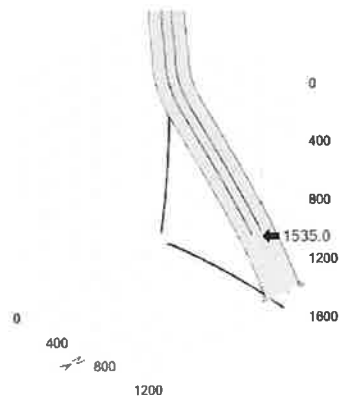
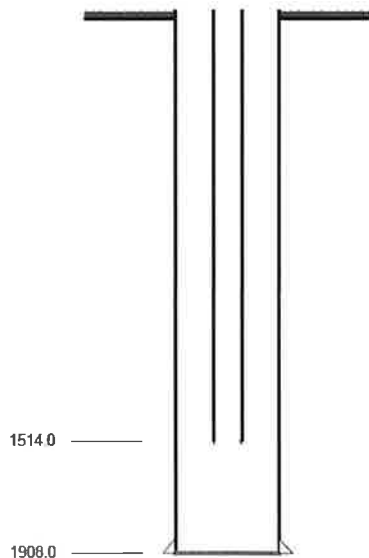

Well name: Dulang B07S
 Total depth: 1908.0 m
 Max Inclination: 48.4° at 1353.0 m
 Max DLS: 4.678"/100ft at 371.0 m
 Min ID: 2.250 in at 1513.0 m
 WHP: 150 psi

Tubing force analysis- till 1,545m (1.1bpm 300scfm)

Reaching Depth

RIH and POOH

between 0.0 m and 1545.0 m

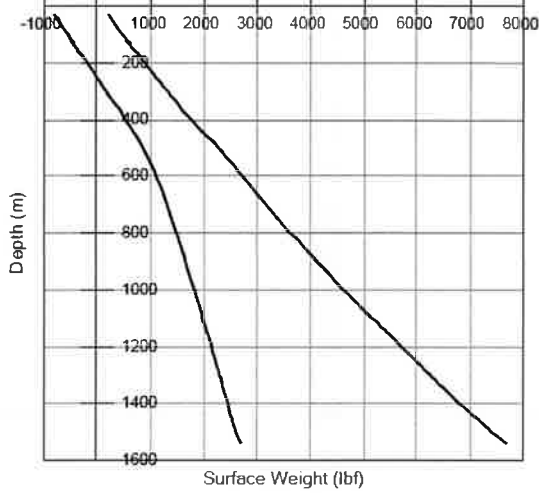

Legend

- Surface Weight RIH
- Surface Weight POOH

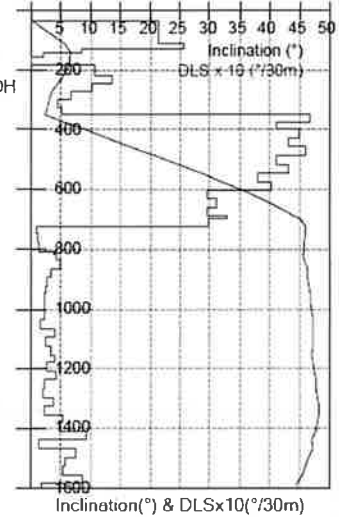

Tubing force analysis- till 1,545m (1.1bpm 300scfm)

Graph(1)

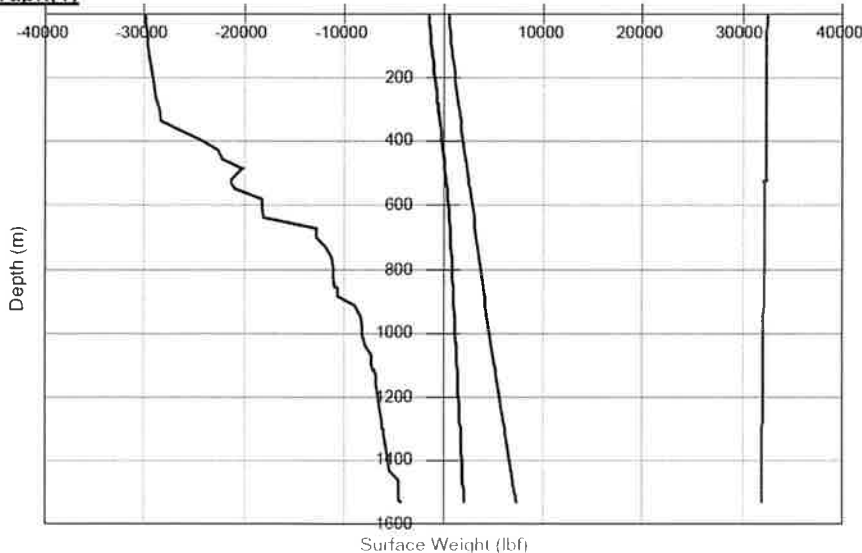

Legend

- SW at Lockup Limit
- Surface Weight RIH
- Surface Weight POOH
- SW at Yield (80%)

Tubing force analysis-set down graph

MD3 ■ The available set-down force at 1545.0 m is -3272 lbf at the end of the string.
The weight indicator reading will be -4090 lbf on surface.
The minimum available set-down force is -3159 lbf at 1433.7 m.

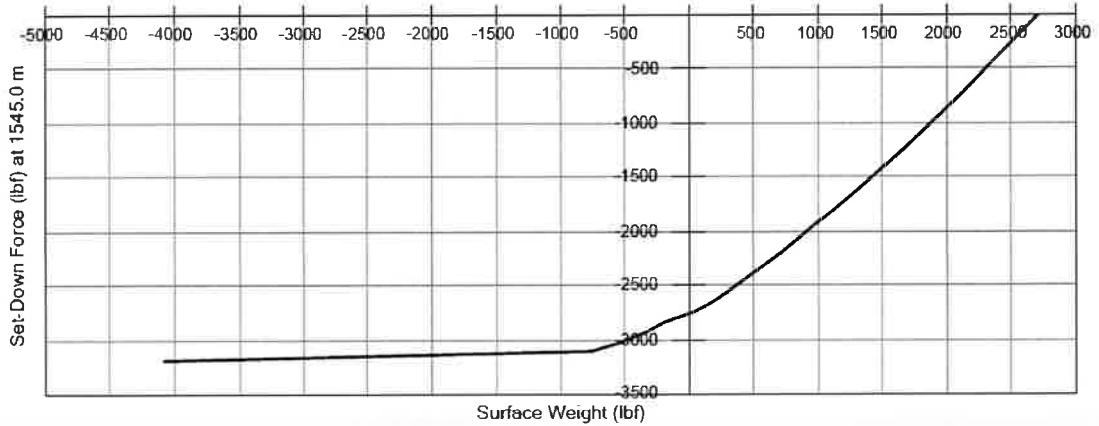

Tubing force analysis- overpull graph

Calculations at 1545.0 m

MD1 ■ The available pick-up at 1545.0 m based on 80% of yield strength is 17502 lbf.
The weight indicator reading will then be 31786 lbf.

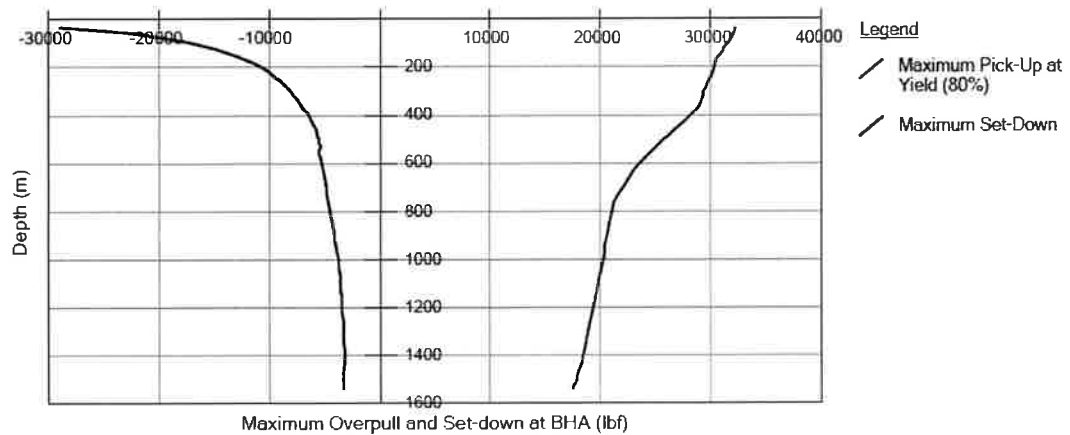

CIRCA simulation- 1.1bpm, 300scfm

Project: New Project		Field-Well: Unknown		Total gas volume: _____		9.1 bbl
Flow Summary				Surface equivalent: _____		2465.0 scf
SUMMARY OF FLOW RESULTS						
Produced Fluids		Perforations		Liquid:		1594.0 bbl/day
Pressure known at		No Production		Gas:		0.43 MMscf/day
Production Mode:		Oil and Gas		Pressure at reel rotating joint: _____		3659.0 psi g
Fluid Composition:				Friction pressure loss on reel: _____		1941.0 psi
Circulated Fluids				Pressure inside WS at Gooseneck: _____		2017.3 psi g
Fluid Composition:		No Free Water		Hydrostatic pressure loss: _____		-1103.0 psi
Liquid:		1.10 bbl/min		Friction pressure loss: _____		1012.3 psi
Solids:		0.00 bbl/min		Equivalent Circulation Density(ECD): _____		1.46 lb/gal (US)
Gas:		300.0 scf/min		BHA total pressure loss: _____		487.3 psi
Circulation Point		1544.00 m		BHA Hydrostatic loss: _____		-18.5 psi
HHP Required		79.86 KW		BHA Friction loss: _____		226.8 psi
COMPLETION:				BHA Kinetic loss: _____		6.8 psi
Wellhead Pressure: _____				Nozzle: _____		272.4 psi
Hydrostatic pressure loss: _____		129.9 psi g		Circulation Point pressure: _____		1621.0 psi g
Friction pressure loss: _____		953.8 psi		FROM REEL ROTATING JOINT TO CIRCULATION POINT:		
Kinetic pressure loss: _____		514.5 psi		Liquid transit time: _____		12 min
Restriction pressure loss: _____		-0.4 psi		Gas transit time: _____		15 min
Equivalent Circulation Density(ECD): _____		2.2 psi		Displacement Volume: _____		11.1 bbl
		7.07 lb/gal (US)		Internal Volume: _____		18.0 bbl
Perforation Pressure: _____				Internal liquid volume: _____		13.2 bbl
Hydrostatic pressure loss: _____		1600.0 psi g		Internal gas volume: _____		5.4 bbl
Friction pressure loss: _____		306.4 psi		(Surface equivalent): _____		4439.2 scf
		0.1 psi		Length of Workingstring on reel: _____		2131.78 m
Bottom Hole Pressure: _____		1986.5 psi g				
FROM CIRCULATION POINT TO WELLHEAD:						
Liquid transit time: _____		9 min				
Gas transit time: _____		8 min				
Annular volume: _____		21.0 bbl				
Volume below circulation point: _____		41.2 bbl				
Total liquid volume: _____		53.1 bbl				

CLEANOUT ANALYSIS

Flow State

Measured Depth[Flow]	Temperature	Completion Pressure	Workingstring Pressure	Concentric Pressure	Completion Liquid Velocity	Workingstring Liquid Velocity	Concentric Liquid Velocity
m					ft/min	ft/min	ft/min
0.0	95.0	129.9	2017.3	0.0	1622	1163	0
4.0	95.4	135.2	2019.4	0.0	1638	1163	0
29.0	97.7	166.0	2025.2	0.0	1422	1164	0
54.0	100.1	194.7	2032.0	0.0	1278	1165	0
79.0	102.5	222.3	2038.7	0.0	1173	1166	0
104.0	104.8	249.1	2045.5	0.0	1082	1168	0
129.0	107.2	275.4	2052.1	0.0	1232	1169	0
132.0	107.4	278.9	2052.9	0.0	1019	1170	0
157.0	109.8	304.9	2059.5	0.0	967	1171	0
182.0	112.1	330.6	2066.1	0.0	923	1172	0
207.0	114.5	356.3	2072.7	0.0	885	1173	0
232.0	116.8	381.9	2079.3	0.0	853	1174	0
257.0	119.2	407.6	2085.9	0.0	824	1175	0
282.0	121.5	433.3	2092.6	0.0	956	1176	0
303.1	123.5	455.3	2099.2	0.0	779	1177	0
329.1	125.9	481.1	2104.8	0.0	758	1178	0
353.0	129.2	507.1	2111.4	0.0	739	1179	0
378.0	130.6	533.1	2117.9	0.0	722	1181	0
403.0	132.9	559.1	2124.3	0.0	706	1183	0
426.0	135.2	585.2	2130.4	0.0	693	1187	0
453.0	137.5	611.3	2136.2	0.0	681	1191	0
478.0	139.9	637.4	2141.6	0.0	670	1195	0
503.0	142.0	663.3	2146.4	0.0	660	1201	0

Flow State (continued)

Measured Depth[Flow]	Temperature	Completion Pressure	Workingstring Pressure	Concentric Pressure	Completion Liquid Velocity	Workingstring Liquid Velocity	Concentric Liquid Velocity
m					ft/min	ft/min	ft/min
529.0	144.1	689.2	2150.7	0.0	781	1206	0
534.1	144.6	695.7	2151.7	0.0	650	1209	0
559.1	146.7	721.2	2155.1	0.0	642	1213	0
584.1	148.7	746.3	2158.0	0.0	636	1218	0
609.1	150.8	770.7	2160.1	0.0	631	1222	0
634.1	152.5	794.8	2161.5	0.0	626	1225	0
659.1	154.3	817.9	2162.3	0.0	621	1228	0
684.0	156.0	840.7	2162.5	0.0	617	1230	0
709.0	157.7	862.9	2162.0	0.0	613	1232	0
734.0	159.3	885.0	2161.2	0.0	609	1233	0
759.0	160.9	907.0	2160.3	0.0	604	1235	0
784.0	162.6	929.2	2159.5	0.0	599	1236	0
809.0	164.2	951.4	2158.6	0.0	594	1237	0
834.0	165.9	973.7	2157.7	0.0	590	1239	0
859.0	167.5	995.9	2156.7	0.0	702	1240	0
887.1	168.0	1003.2	2156.3	0.0	585	1240	0
892.1	169.7	1025.5	2155.2	0.0	581	1242	0
917.1	171.3	1047.7	2154.0	0.0	577	1243	0
942.0	172.9	1069.9	2152.7	0.0	574	1245	0
967.0	174.5	1092.2	2151.4	0.0	571	1246	0
992.0	176.1	1114.4	2150.0	0.0	568	1247	0
1017.0	177.7	1136.7	2148.5	0.0	565	1249	0
1042.0	179.3	1158.9	2146.9	0.0	562	1250	0

CLEANOUT ANALYSIS

Flow State (continued)

Measured Depth(Flow) m	Temperature	Completion Pressure	Workstring Pressure	Concentric Pressure	Completion Liquid Velocity ft/min	Workstring Liquid Velocity ft/min	Concentric Liquid Velocity ft/min
1087.0	180.9	1181.2	2145.3	0.0	558	1251	0
1092.0	182.5	1203.8	2143.8	0.0	558	1253	0
1117.0	184.1	1225.9	2141.9	0.0	563	1254	0
1128.0	184.8	1238.0	2141.2	0.0	562	1255	0
1153.0	186.5	1258.5	2139.5	0.0	548	1256	0
1178.0	188.1	1280.9	2137.7	0.0	547	1258	0
1203.0	189.8	1303.4	2135.8	0.0	545	1259	0
1228.0	191.2	1325.8	2133.9	0.0	542	1260	0
1253.0	182.8	1348.3	2131.9	0.0	540	1262	0
1278.0	194.4	1370.7	2129.9	0.0	538	1263	0
1303.0	198.0	1393.2	2127.9	0.0	543	1264	0
1315.0	198.7	1404.2	2126.5	0.0	538	1265	0
1340.0	198.3	1428.6	2124.3	0.0	534	1266	0
1385.0	199.9	1449.0	2121.9	0.0	532	1268	0
1390.0	201.5	1471.6	2119.6	0.0	530	1269	0
1415.0	203.0	1494.2	2117.3	0.0	527	1271	0
1440.0	204.6	1517.0	2115.1	0.0	524	1272	0
1465.0	208.2	1539.9	2112.9	0.0	526	1274	0
1488.0	208.4	1542.8	2112.7	0.0	522	1274	0
1493.0	208.0	1585.9	2110.5	0.0	522	1276	0
1513.0	209.3	1584.6	2108.9	0.0	582	1277	0
1513.2	209.4	1585.1	2108.9	0.0	517	1277	0
1514.0	209.4	1585.9	2098.9	0.0	516	1157	0

Flow State (continued)

Measured Depth(Flow) m	Temperature	Completion Pressure	Workstring Pressure	Concentric Pressure	Completion Liquid Velocity ft/min	Workstring Liquid Velocity ft/min	Concentric Liquid Velocity ft/min
1515.0	209.5	1588.0	2090.3	0.0	85	3159	0
1528.0	210.2	1600.0	2016.7	0.0	84	3182	0
1543.7	211.4	1621.2	1898.0	0.0	89	3222	0
1544.0	211.4	1621.6	1893.9	0.0	88	13354	0
1558.1	212.3	1635.0	0.0	0.0	0	0	0
1583.1	214.0	1659.1	0.0	0.0	0	0	0
1608.1	215.7	1683.4	0.0	0.0	0	0	0
1633.1	217.3	1707.7	0.0	0.0	0	0	0
1658.1	219.0	1732.0	0.0	0.0	0	0	0
1683.1	220.7	1756.7	0.0	0.0	0	0	0
1708.1	222.5	1781.6	0.0	0.0	0	0	0
1733.0	224.2	1806.9	0.0	0.0	0	0	0
1758.0	226.0	1832.3	0.0	0.0	0	0	0
1783.0	227.8	1857.9	0.0	0.0	0	0	0
1808.0	229.5	1883.6	0.0	0.0	0	0	0
1833.0	231.3	1909.3	0.0	0.0	0	0	0
1858.0	233.1	1935.1	0.0	0.0	0	0	0
1883.0	234.9	1960.9	0.0	0.0	0	0	0
1908.0	238.7	1986.5	0.0	0.0	0	0	0

CLEANOUT ANALYSIS

Clean Summary

SUMMARY OF HOLE CLEANING RESULTS

Initial Condition	
% of fill interval occupied by solids before cleanout	100.0 %
Top of fill	1515.01 m
Deepest Circulation point	1543.89 m
Bottom of fill	1543.89 m
Initial Volume of Solids	3.3 bbl
Initial Mass of Solids	1882.4 lb
Solids type:	Mud Residue/Formation Fines
Fluid Description:	Mixed Water

Penetration Hole Cleaning Mode:	
Penetration rate	1.0 ft/min
Penetration time	1.59 hr
Solids volume in the well after penetration	2.7 bbl
Solids mass in the well after penetration	1370.4 lb

Circulation Hole Cleaning Mode:	
Hole circulation time	3.25 hr
Solids volume in the well after circulation	0.5 bbl
Solids mass in the well after circulation	245.4 lb

Wiper Trip Hole Cleaning Mode:	
Wiper Trip Scheme:	User Specified rate, Tornado rot
Wiper trip time	0.20 hr
Solids volume in the well after wiper trip	0.5 bbl
Solids mass in the well after wiper trip	245.4 lb

Volume of Fluids Pumped During Penetration, Circulation & Wiper Trip:	
Gas volume	90679.2 scf
Liquid Volume	332.6 bbl
Penetration, Circulation & Wiper Trip time	5.04 hr

Circulation results at point of Maximum Solids Head:

Percentage initial fill	% Left in hole after CBU
100%	14.6
90%	16.9
50%	30.1

Cleanout unable to lift 100% solid inside well!!

CLEANOUT ANALYSIS

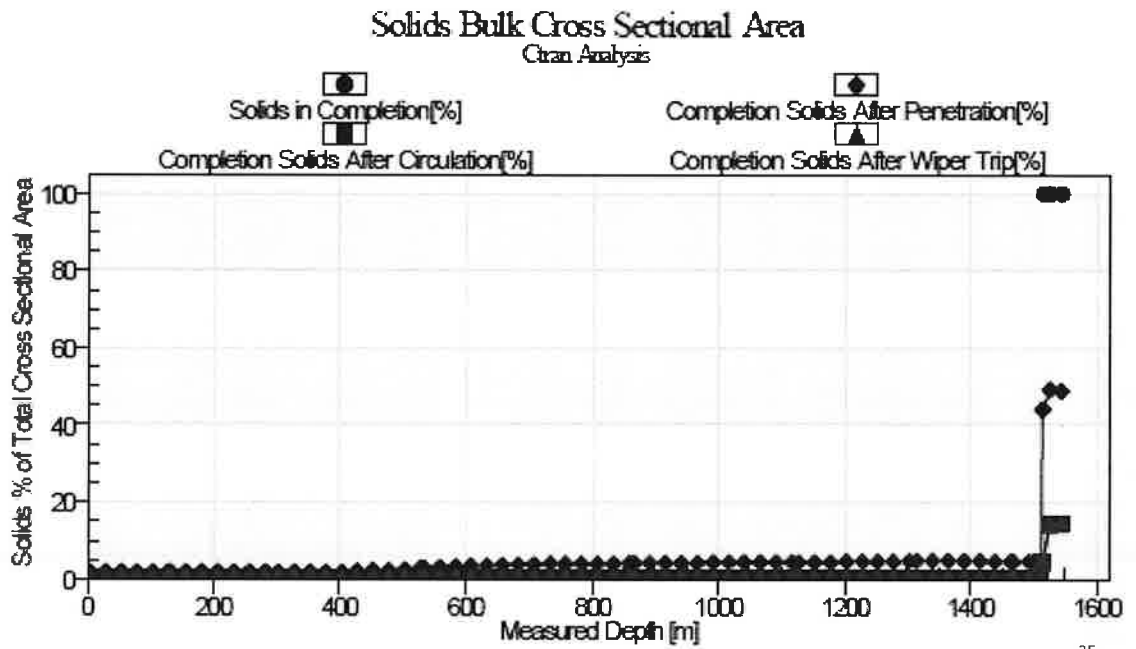

35

CLEANOUT ANALYSIS

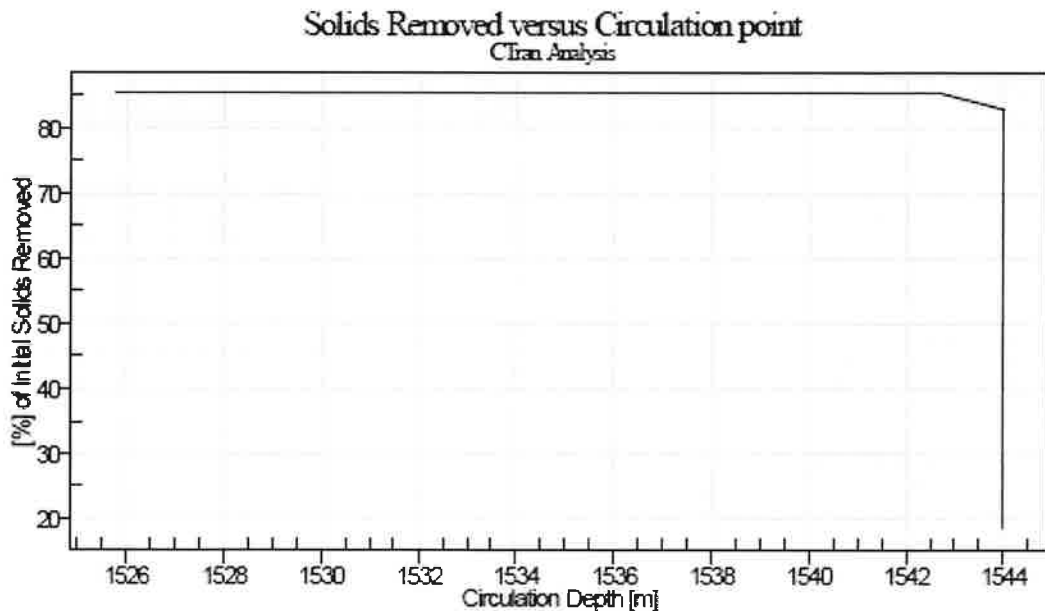

36

CLEANOUT ANALYSIS

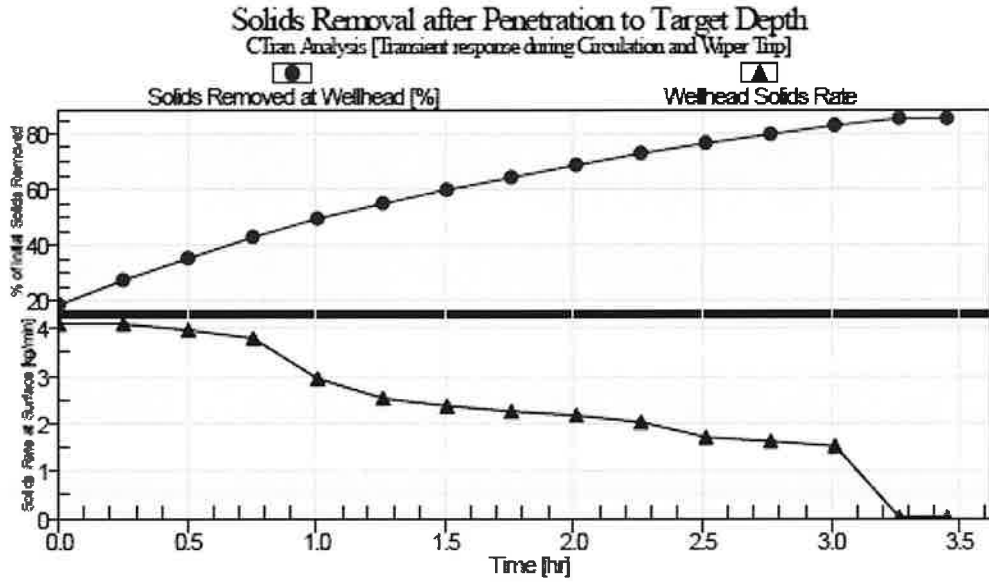

37

CLEANOUT ANALYSIS

Tripping Speed to be used while Pulling Out of Hole
C'Iran Analysis

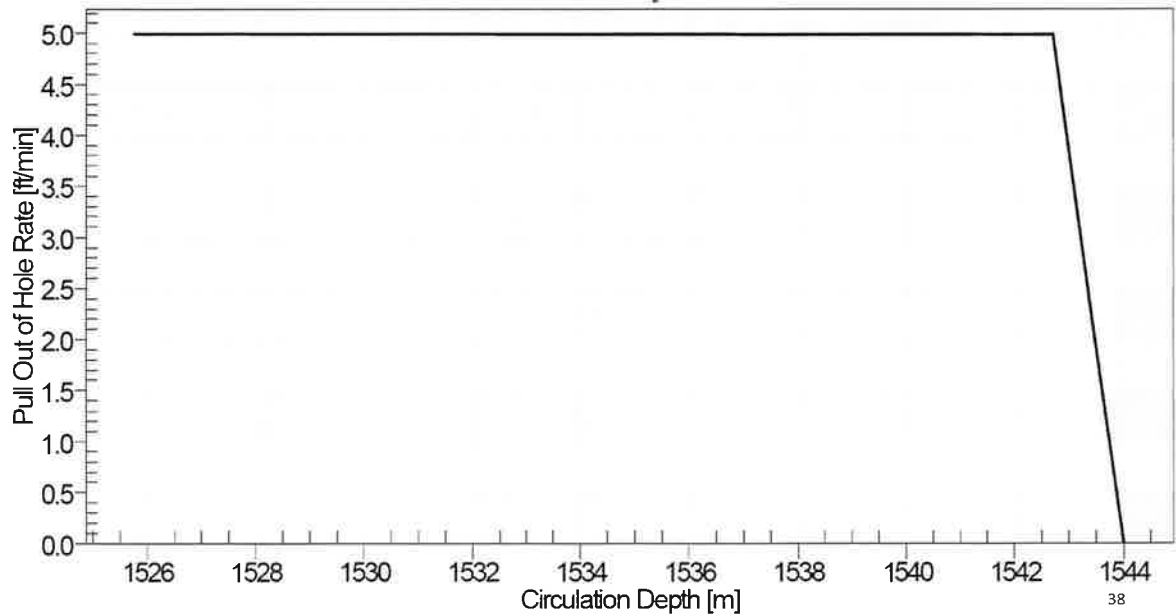

38

TFA SENSITIVITY ANALYSIS

TFA SENSITIVITY ANALYSIS – IDLE RATE

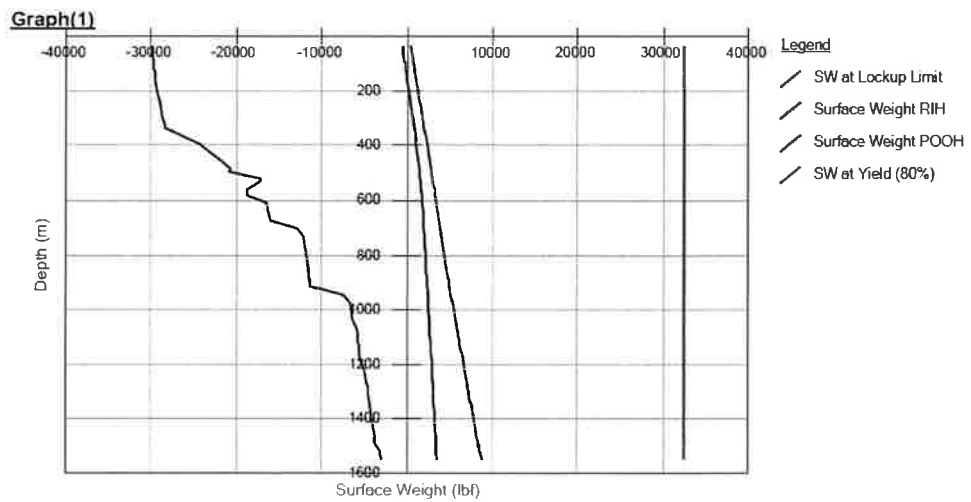

TFA SENSITIVITY ANALYSIS – 1.1 BPM 300 SCFM 0.2 FF

Graph(1)

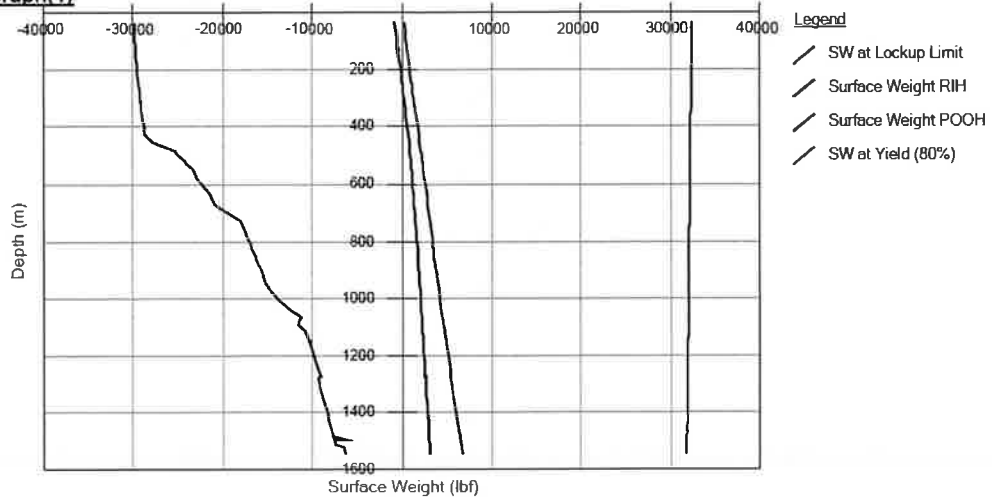

TFA SENSITIVITY ANALYSIS – 1.1 BPM 300 SCFM 0.3 FF

Graph(1)

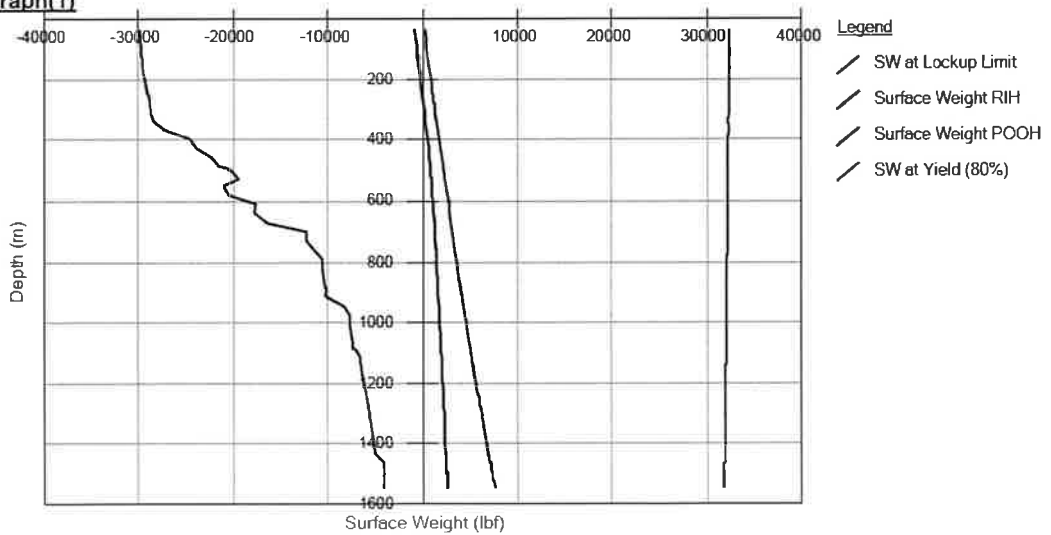

TFA SENSITIVITY ANALYSIS – 1.1 BPM 300 SCFM 0.4 FF

Graph(1)

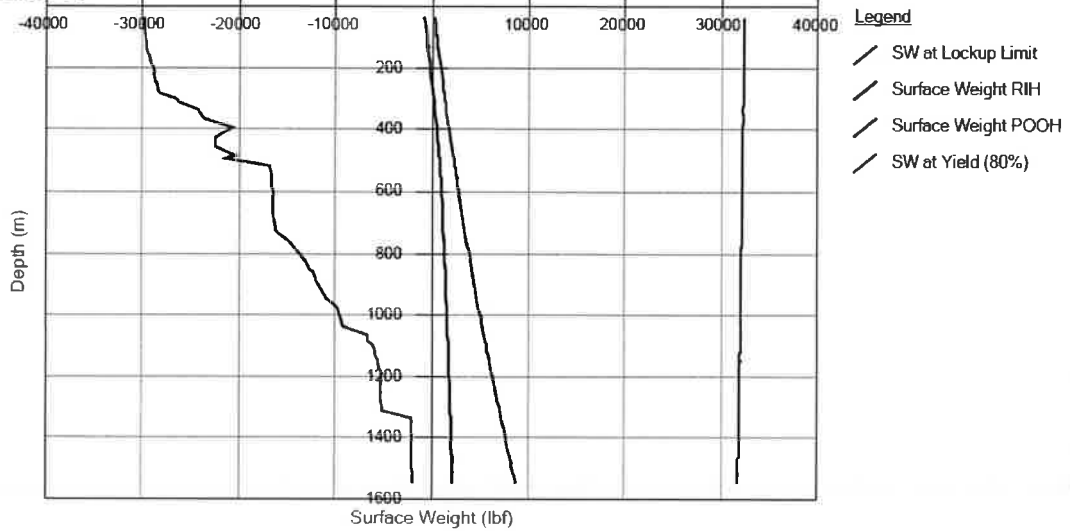

TFA SENSITIVITY ANALYSIS – 1.1 BPM 300 SCFM 0.5 FF

Graph(1)

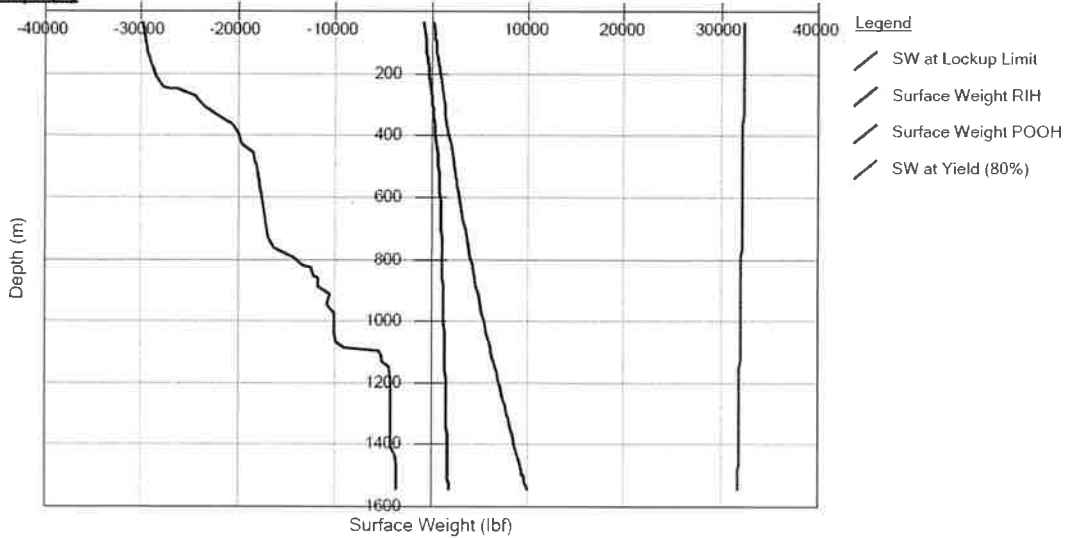

TFA SENSITIVITY ANALYSIS – SUMMARY

Friction Factor	Depth (m)	Lock-up Limit (lbf)	RIH Weight (lbf)	POOH Weight (lbf)	Max Pulling Weight at 80% Yield Limit
0.2	500	-25,230	903	2,167	32,214
	1000	-13,788	2,066	4,273	32,034
	1,545	-6,300	3,178	6,794	31,773
0.3	500	-20,439	843	2,240	32,230
	1000	-7,675	1,819	4,653	32,010
	1,545	-4,089	2,710	7,707	31,786
0.4	500	-21,369	786	2,317	32,213
	1000	-9,586	1,587	5,077	32,019
	1,545	-1,968	2,286	8,758	31,774
0.5	500	-18,142	136	2,392	32,213
	1000	-9,954	1,363	5,553	32,043
	1,545	-3,635	1,893	9,963	31,784

Pro & Cons Deployment vs conventional

Conventional BHA

Pro	Cons
<ol style="list-style-type: none"> 1. Crew familiarity 2. Minimal rig up/down time (1 additional item – Deployment BOP +/- xover) 3. Faster BHA makeup / strip down 4. Regular CT operational/standby charges 	<ol style="list-style-type: none"> 1. Does not address likelihood of CT string entangled and helical lock against well long string. 2. Unable to disconnect using MHA disconnect. IF stuck in completion annulus, disconnect will likely be below entanglement depth. 3. Will be forced to use chemical cutters if desire to disconnect on stuck. Expansive, difficult and very time-consuming intervention. 4. Extremely difficult/almost impossible to retrieve whole FISH if forced to sever the CT string using plasma cutter. 5. CT string will be left downhole. If cut is only feasible at depth inside the completion tubing, additional resistance to producing well with fish left in hole. 6. Additional lost in hole charges for CT string. 7. If extended lengths of CT string is left in hole, the remaining string will no longer be usable as is. Time, effort and additional cost to demob reel, spool out remaining string, spool in new string, reinspect and mob back to location etc.

47

Extended BHA

Pro	Cons
<ol style="list-style-type: none"> 1. Addresses likelihood of CT string entanglement and helical lock against well long string. 2. Gain ability to disconnect IF stuck in completion annulus 3. Disconnecting is a fast and easy process. 4. Only BHA will be left downhole if disconnect. Lesser resistance to producing well with fish left in hole. 5. Easier to retrieve FISH if disconnect at MHA. 6. CT string can be immediately used for subsequent wells with zero additional effort, time or cost. As such no delay to subsequent CT intervention plan after disconnect. 	<ol style="list-style-type: none"> 1. Minimal rig up/down time (1 additional item – Deployment BOP) 2. Additional extended BHA makeup / strip down. 3. Additional CT operational/standby charges.

48

Previous History for Dulang B7S

49

Summary

9 May 2020

1. CT RIH to Tag No-GO nipple.
2. CT able to tag the NO-GO without any issue after slickline fish has been retrieved.

10 May 2020

1. CT RIH to perform SCO inside casing.
2. CT weight during entering casing RW:2200lbs
3. CT get return 0.3% sand with D801 gel at depth 5020ft
4. CT continue RIH at HUD at depth 5028ft and continue penetrate and experienced HPW at depth 5040ft. CT able to release with overpull 14500lbs. (Target SCO depth: 5052ft)
5. After CT is free, straight POOH inside tubing and CBU6
6. POOH to surface

50

Summary

10 May 2020

1. 4 hours stuck during cleanout stage inside casing
2. Overpull 9,500 lbs
3. Normal pick-up weight, 5,000 lb

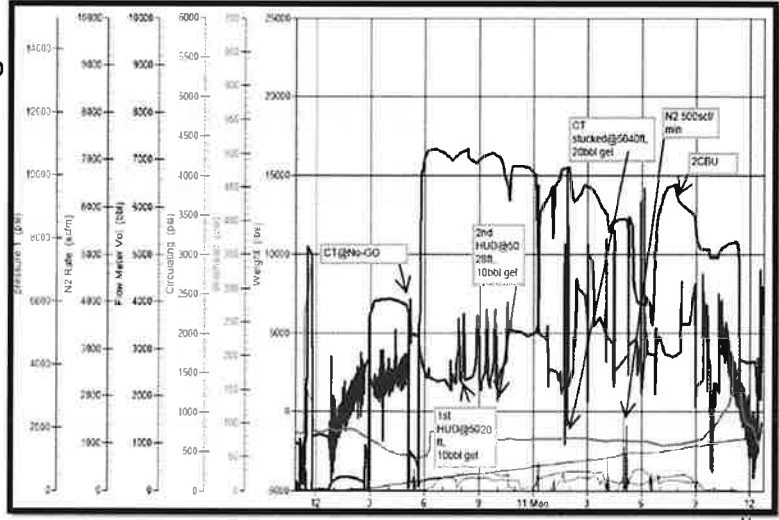

Thank you