



This example covers a deviated producer (74deg) logged with Multiple Probe Tools, two DEFT, and stationary water velocity measurements. The well is producing from 4 sets of perfs, through isolated, internal gravel pack screens. The PLT data does not cover the deepest set of perfs. The following features are illustrated in this example:

- Handling X-Y caliper data.
- Image views.
- Well views.
- Working with Multiple Probe Tools.
- Loading / processing of stationary measurements.
- By-passing slippage correlation when enough information is provided.

The data for B05 is contained in several files:

- B05_gwd.las: 'General well data'; contains an open-hole gamma-ray and a deviation survey,
- B05d1.las, B05d2.las, B05u1.las, B05u2.las: flowing survey log data (except stations),
- B05_sta_8071.las, B05_sta_8325.las, B05_sta_8578.las: stations with water velocity (name indicates depth in ft),
- B05.epv: PVT file.

B05.1 • Create B05 and load the general well data

- Start Emeraude and create a new document with oilfield units. In the 'Document' panel, select 'Load Well Data' and load the channels present in the file B05_gwd.las: open-hole gamma ray and deviation survey. Only the gamma-ray is plotted by default. *The creation of a well view will be illustrated later.*
- In 'Document – Well Details', Define the Perforations and Reservoir zones as given below (note that a name can be given to them):

Perforations (ft)		Reservoir zones (ft)	
8248	8314	8232	8317 A
8461	8530	8447	8535 B
8615	8734	8581	8737 C
9009	9068	8995	9074 D

B05.2 • Create the survey and load the log data

- In the survey panel, click 'Information' to create the survey. Call it Production#1, short name P1. Select 'Load' and 'Add' the files: B05d1.las, B05d2.las, B05u1.las, B05u2.las.

The depth is always increasing in these LAS files. However the depth direction in the logging file is used by Emeraude as a starting point to determine whether a LAS file is an Up or a Down pass. Consequently, you will need to change the pass type/direction (and index) manually in the load dialog, Fig. B05.1.

- Set the Bubble count units to Hz by pressing on each button  and import.

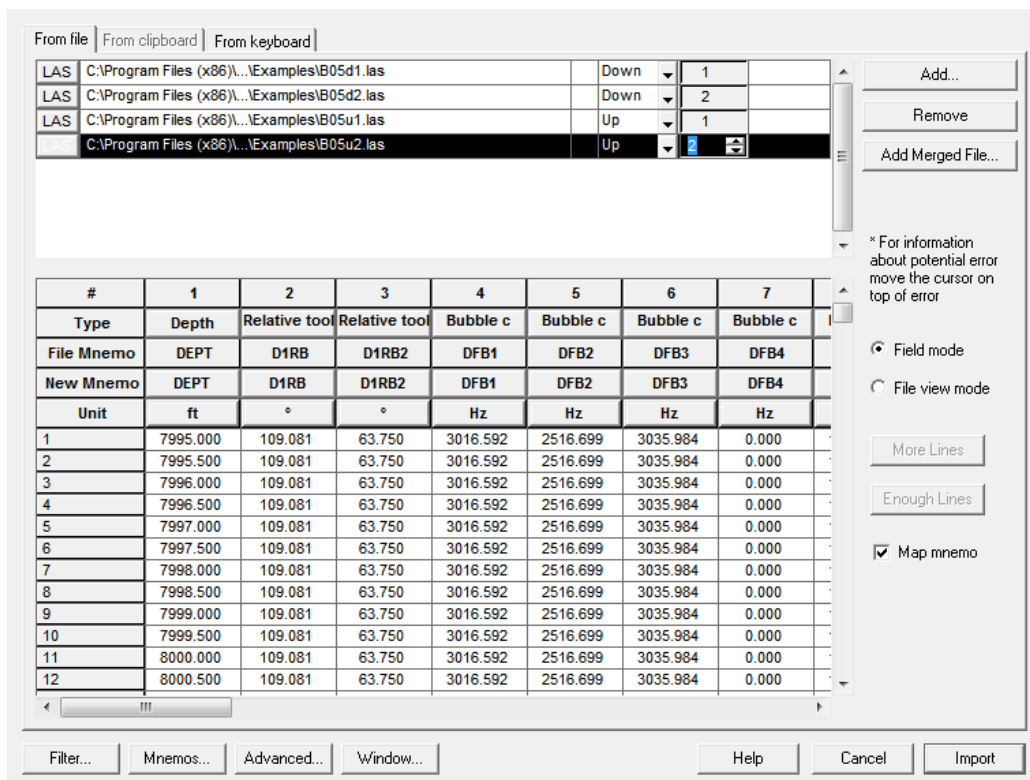



Fig. B05.1 • Loading the log data

- Press on  in the toolbar to make a general reset of all the channel scales:

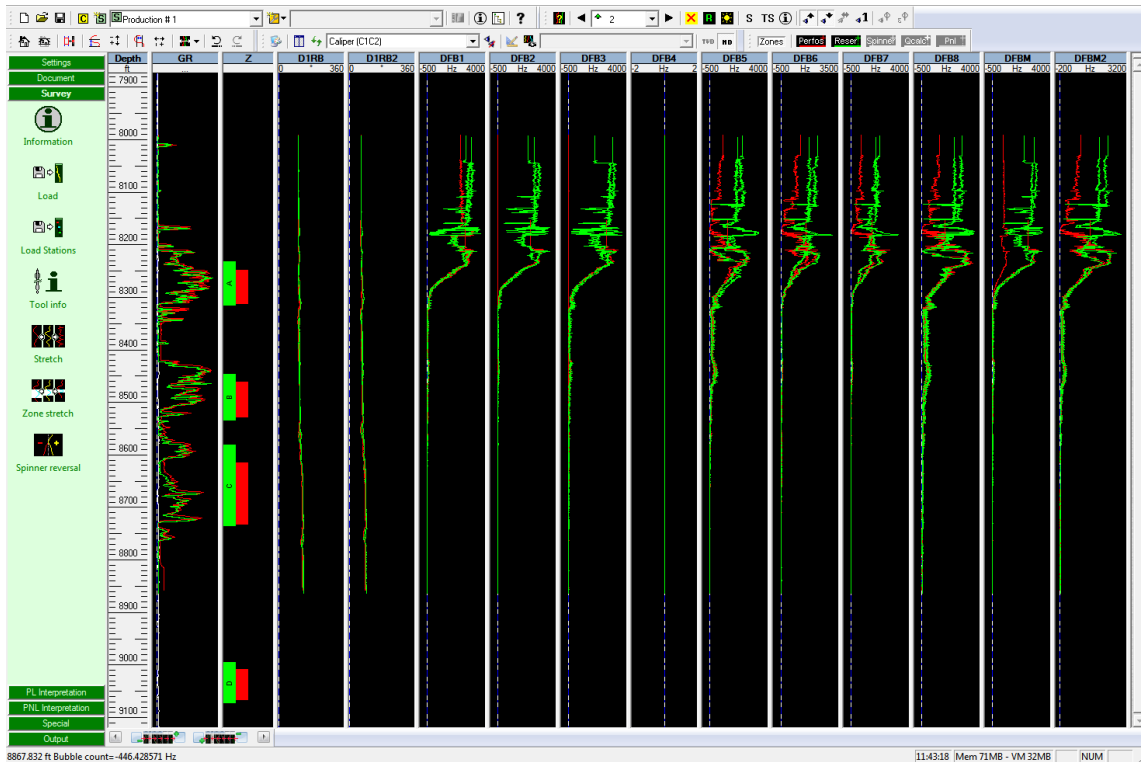



Fig. B05.2 • Log data loaded

- Click the  option next to the hidden plot list to access the dialog below, Fig. B05.3.
- Use '<<<' to move all views to the left.
- Using the 'Ctrl' key for multiple selections, highlight on the left part: Depth, Zones display, SCVL, C1C2, SPIN, GR, WPRE, WTEP. Move the selected views to the right with '>'. Using the Up and Down arrows, you can set a specific ordering for the views to be displayed. Validate with OK.

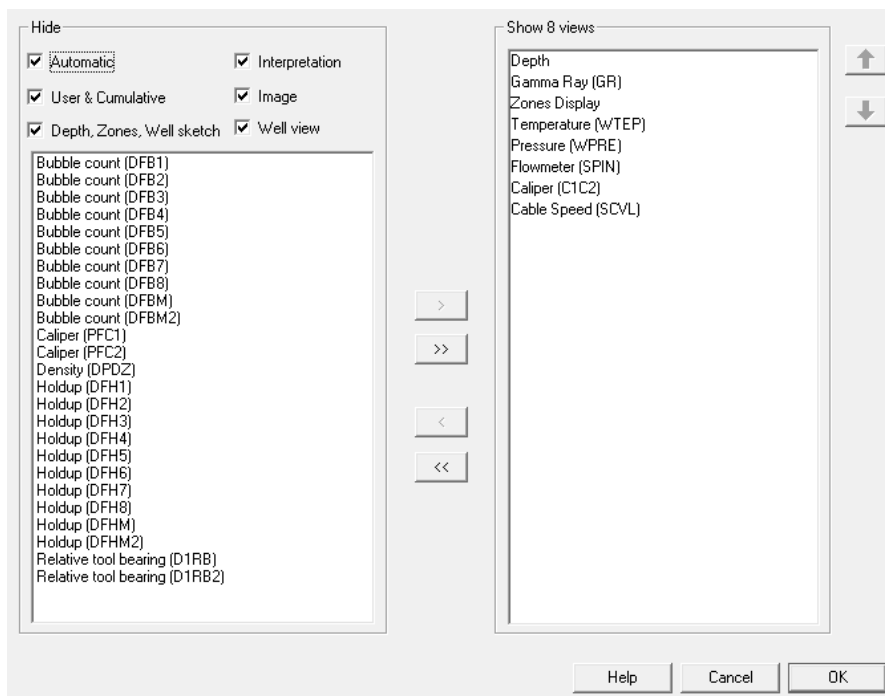

Fig. B05.3 • Show/hide views

- Tile the plots. The screen is re-organized as on Fig B05.4.

The C1C2 channels are constructed automatically from the PFC1 and PFC2 channels. Their values are calculated as $\text{CaliperC1C2} = \sqrt{\text{CaliperC1} \times \text{CaliperC2}}$.

Note: See 'How to use caliper data' in the online help for more detailed explanation of X-Y caliper data.

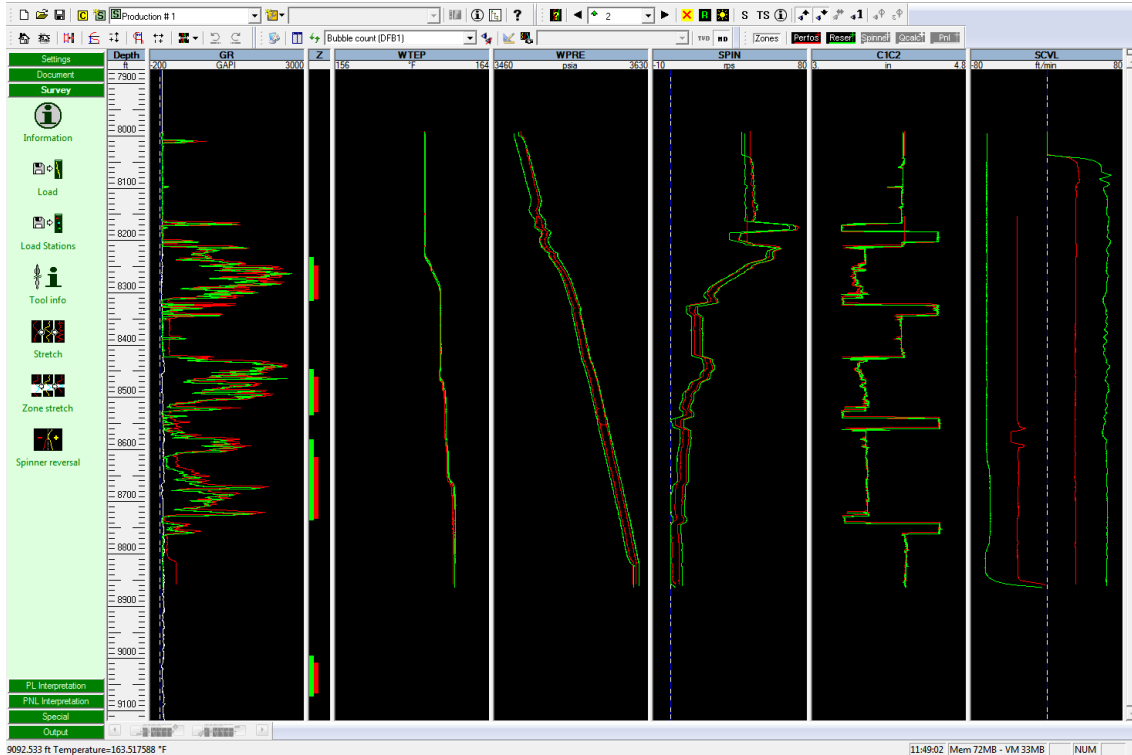

Fig. B05.4 • Screen re-organized

- Go to the 'Survey' page and select 'Load Stations'. Use the 'Add' button to select the three files: B05_sta_XXXX.las. A depth channel is present in those files. Otherwise, at the time of loading, Emeraude would prompt you for the depth of each station. *It is a recommended practice to name the stations after the depth.*

When the stations are loaded, an additional track appears with the memo VW. This track displays 3 (sets of) discrete values, one for each station. Inside the data browser you can check the contents of the 'Log Data', Fig. B05.5. If you did not set the pass type/index right for the last two passes you can still change them inside the browser: select the pass, then right click and select 'Properties'.

If you open one of the station nodes, and select the VW channel, the 'Plot vs. Time' tab displays a graph of VW versus time.

In this particular case the station contains only 3 identical values. Raw station data will usually exhibit a distinct behavior with significant variations.

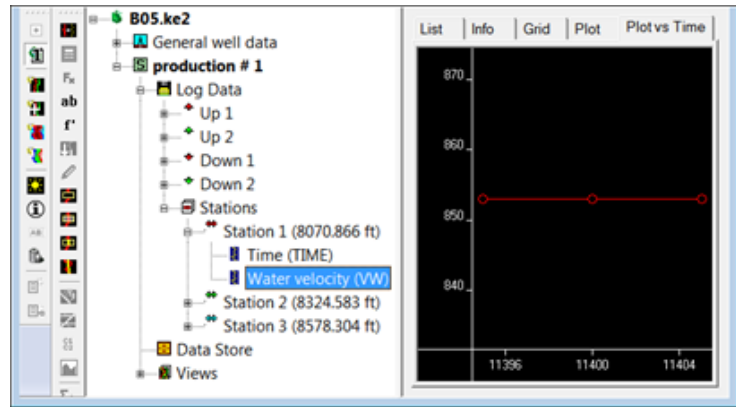

Fig. B05.5 • Water velocity

Note that the 'Stations' node allows displaying the same measurement for several stations at a time in the associated 'Plot vs Time' tab.

- Select the 'Stations' node, activates the 'Plot vs Time' tab, call the popup menu with a right mouse click, and under 'Display multiple data', select the water velocity. The three stationary measurements are displayed.

The same feature is offered at the level of each station node, to display different measurements of the same station in the same plot. Follow the same path as described above, but select 'Station 1' node instead of the 'Stations' node.

Stationary data can be edited. For instance, the 'Delete parts' and the 'Hide parts' options work versus time and can be executed directly from the 'Plot vs time'.

With the browser opened, note that the loaded data is arranged in sub nodes for easy reading (e.g. PFCS raw channels).

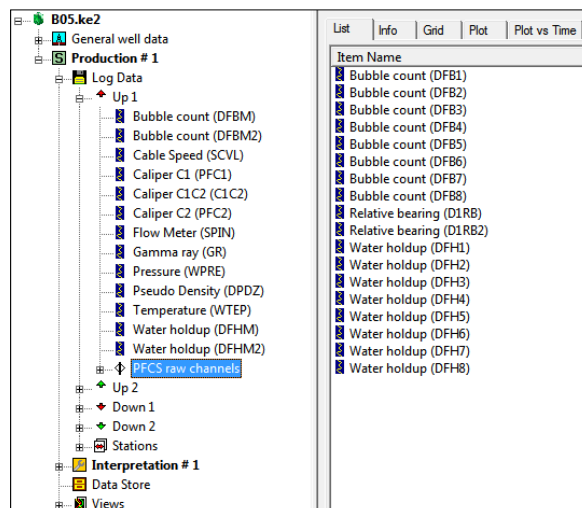



Fig. B05.6 • Data organization

- Use the snapshot  button to 'Add' the current screen layout as 'Original' for instance.

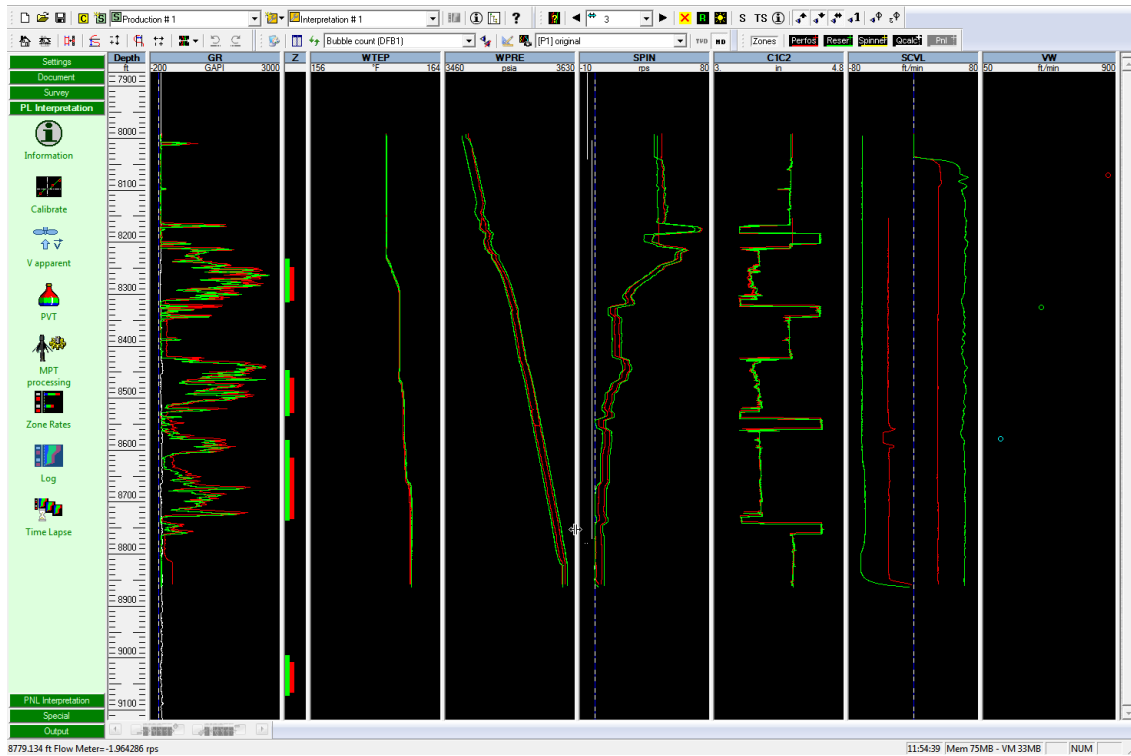

Fig. B05.7 • Original layout

B05.3 • Settings - Multiple Probe Tools

There are two DEFT tools in the string, to which we will refer as DEFT1 and DEFT2. DEFT1 corresponds to the mnemonics:

- DFB1, DFB2, DFB3, DFB4, DFBM, DFH1, DFH2, DFH3, DFH4, DFHM, D1RB

And DEFT2 to:

- DFB5, DFB6, DFB7, DFB8, DFBM2 DFH5, DFH6, DFH7, DFH8, DFHM2, D1RB2

In order to later present images, a required step is to check whether the current list of tool definition includes the above. Go to 'Settings' – 'Multiple Probe Tools', Fig. B05.8.

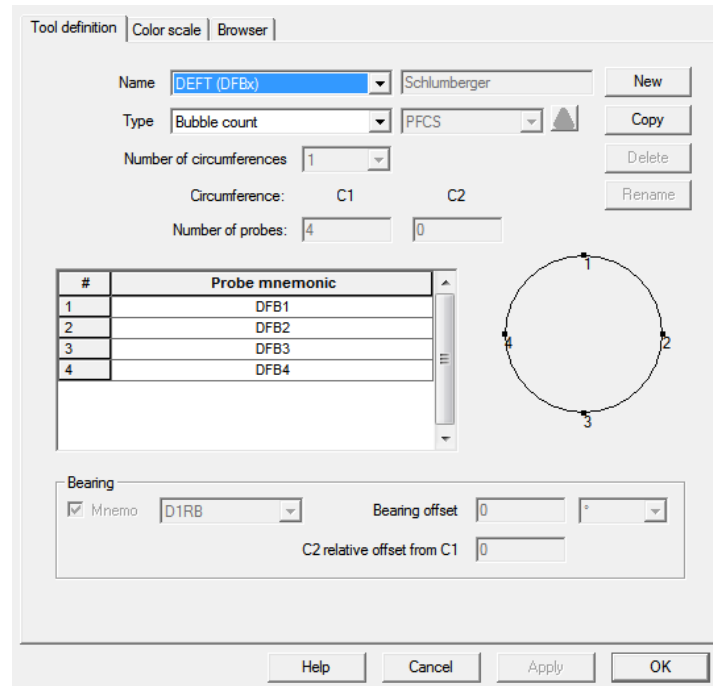

Fig. B05.8 • MPT - Settings

Emeraude 2.60 contains default definitions for the DEFT and PFCS bubble counts, the DEFT and PFCS holdups, the GHOST bubble counts and holdups, and some combinations of these tools. The default DEFT probe / mnemo assignment is the same as for DEFT1 above. The same with the built-in tool DEFT 5-8, whose probe / mnemo assignment is the same as for DEFT2 above.

B05.4 • Survey – Tool info

- Go to 'Survey' – 'Tool info', the second tab gives the list of Multiple Probe Tools found in the current survey. The list shows here as expected DEFT (DFBx), DEFT 5-8 (DFBx), DEFT (DFHx), and DEFT 5-8 (DFHx).

Probe status

For each particular tool the probe status can be assigned in the grid as either 'Active', 'Disable', or 'Ignore'. The status influences the bubble/holdup images and also the reference channel processing.

Tool Geometry :

Geometric parameters are entered at this level: Lp/La, Lb, Lc and IDmax; they are defined in the 'Schematic' dialog opposite. For some tools, a predefined geometry can be selected using the button **Parameters**

- Select the 'DEFT (DFHx)', and then enter Lp/La = 0.75, Lb = 0, Lc = 0, and IDmax = 11 in.

The tool geometry is not required for the creation of image views.

The geometry must be defined:

- To visualize cross-sections of the wellbore.
- Process the data (further next).

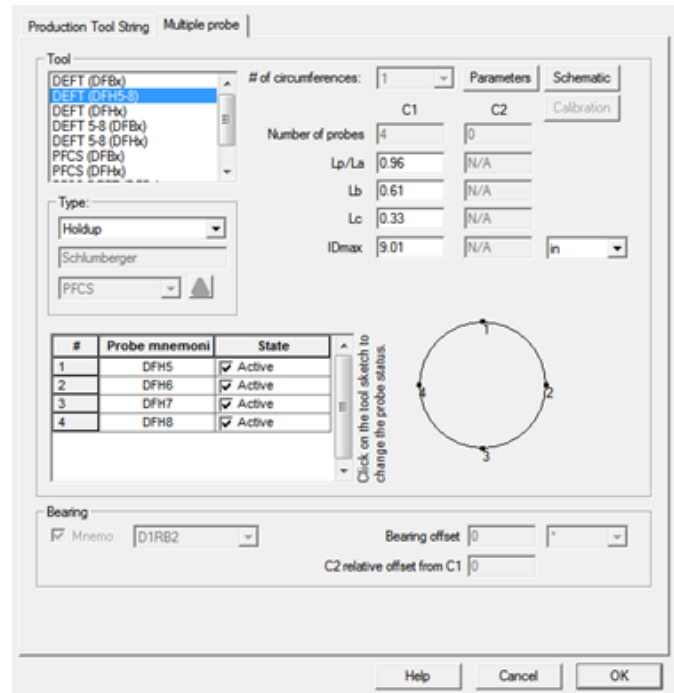

Fig. B05.9 • Tool information

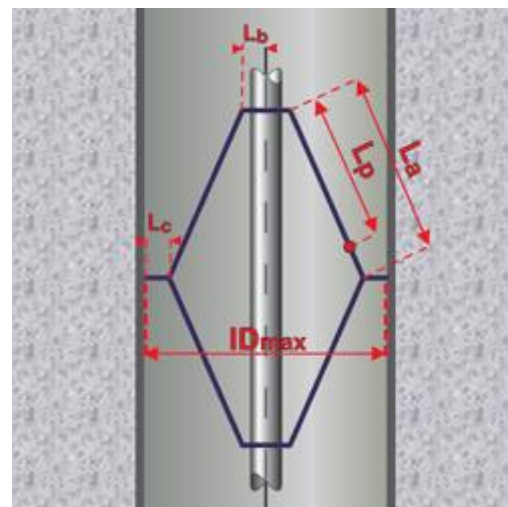

Fig. B05.10 • Schematic

B05.5 • Image views

- In order to first look at DEFT1, re-arrange the screen as on Fig. B05.11 and show the following channels: GR, Z, D1RB, DFH1, DFH2, DFH3, DFH4. Based on this layout it is decided to make an image for pass Down2, bearing in mind that DFH4 may have to be ignored.
- To view all probes with the same appropriate scale, right click on one probe view, Horizontal scale, click on Full log range and tick 'Apply to all Water holdup data from the same MPT'.

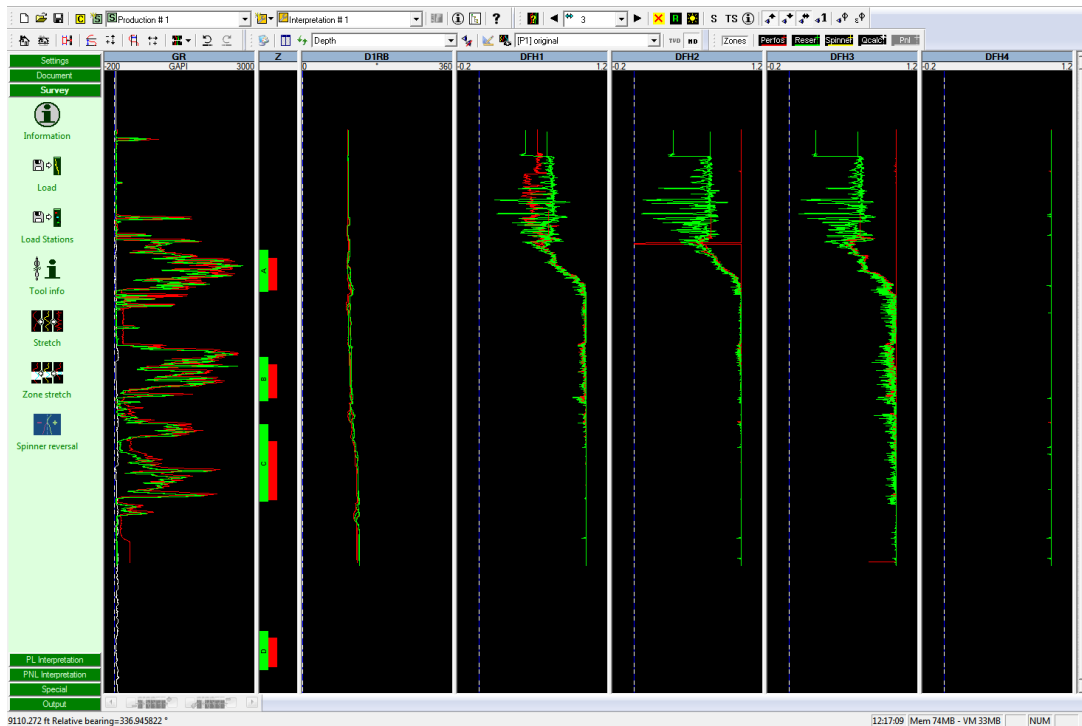



Fig. B05.11 • Layout for DEFT1

- Open the data browser and select 'Create image view', either in the browser popup menu or using the  icon of the browser toolbar.

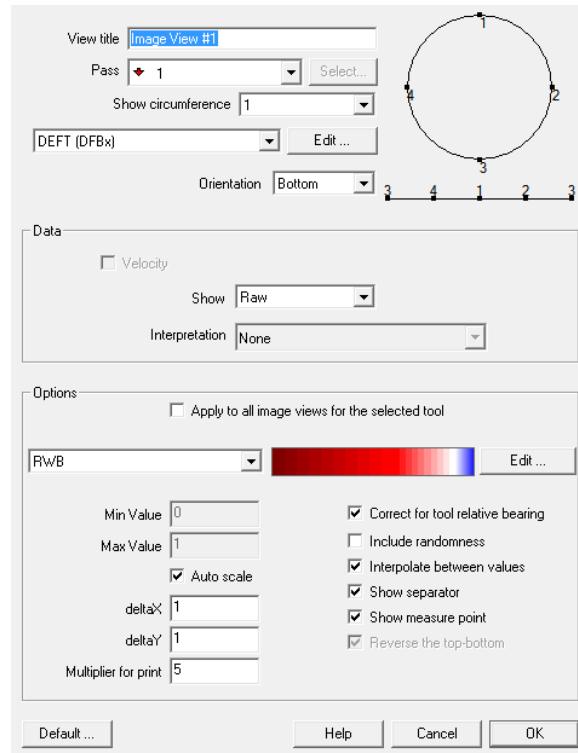

Fig. B05.12 • Image view creation

The 'Image View' dialog allows the definition of:

- A specific title.
- The tool to be used from the list defined in the 'Survey' – 'Tool Info' dialog still accessible via the 'Edit' button.
- The particular pass or combination of passes to display in the image.
- The tool orientation, defined as the position of an imaginary user looking at the tool: from the top, the bottom, the left side or the right side (top and bottom could be reversed for the two last choices).
- The data to use (raw or reconstructed, more on this next) and from which interpretation.
- The image view color scale.

At this stage, you can recall the 'Tool info' and/or the 'Color scale' dialogs (via the 'Edit' buttons) in order to view/edit the current options. Other controls specific to the image view are:

- 'Min' and 'Max' define the scale range - if 'Auto Scale' is checked, taken as the channel bounds.
- 'deltaX' & 'deltaY' define the horizontal & vertical resolution in pixels. A multiplier is used for print.
- 'Correct for tool relative bearing' corrects the image for the tool rotation using the relative tool bearing: the center of the view represents the top of the well.
- Include randomness: when the image is drawn using interpolation between two neighbor probes, this option adds random variations around the linear trend.
- 'Interpolate between values': create a linear interpolation between two consecutive probe measurements.

- 'Show separator': show vertical lines splitting the track in as many intervals as there are probes.
 - 'Show measure point': shows the probe position (undulating white line on the view in the middle of each track).
- Select DEFT (DFHx) for the tool, and Pass Down 2, and validate. The image view is created, Fig B05.13:

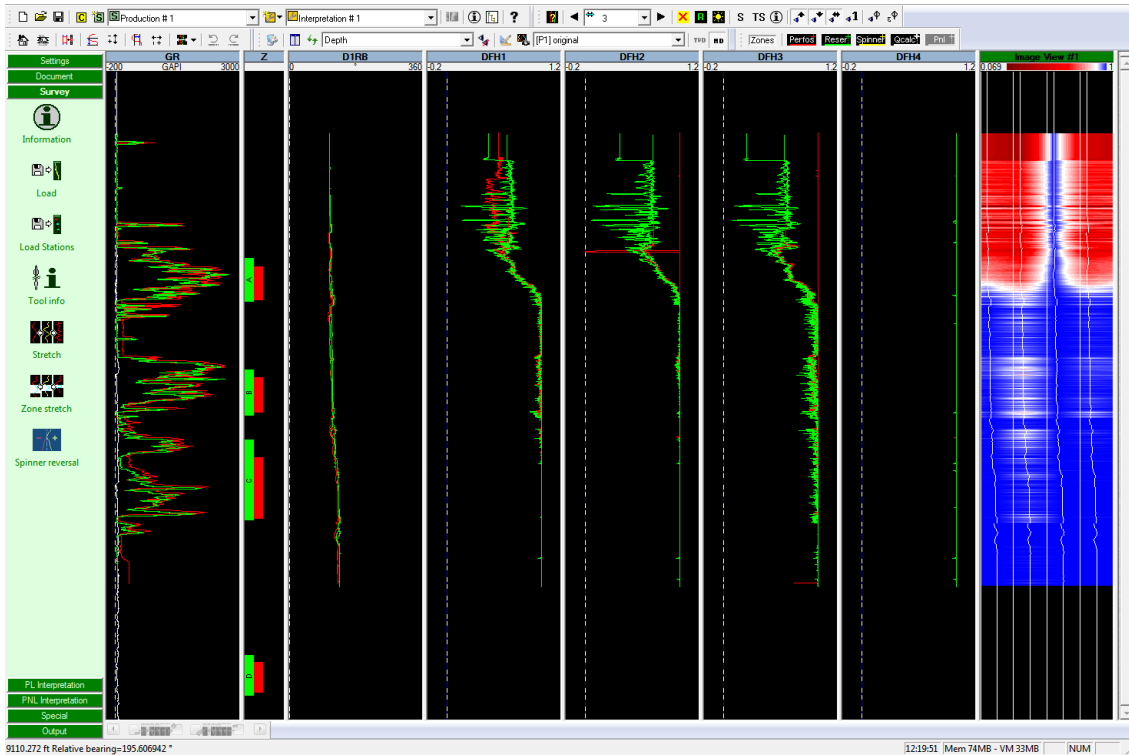

Fig. B05.13 • First image view created

An image corrected for relative tool bearing shows the top of the pipe at the center of the view. The view below indicates water at the top only because we included DFH4 in the image and this channel is erroneous. Note that you can also create a bubble count image in the same manner.

As an exercise, you can change the view orientation to see the change. Then, set back the orientation to 'Bottom'.

B05.5.1 • Changing the probe status

- Bring up the view properties by a right click on the image view and select 'Properties'.

Next to the tool name 'DEFT (DFHx)' is an 'Edit' button that takes you directly to the 'Tool Info' dialog, 'Multiple probe Tool' tab. In this dialog you can change the status of DFH4. When you click the status is changed in turn to 'Disable', then 'Ignore', and back to 'Active'.

- Set the status of DFH4 to 'Disable'. Validate the change and on the Image view 'Properties' dialog, select 'Apply' to see the change.

When the status is set to 'Disable', no section is drawn that would use the disabled probe readings, Fig. B05.14.

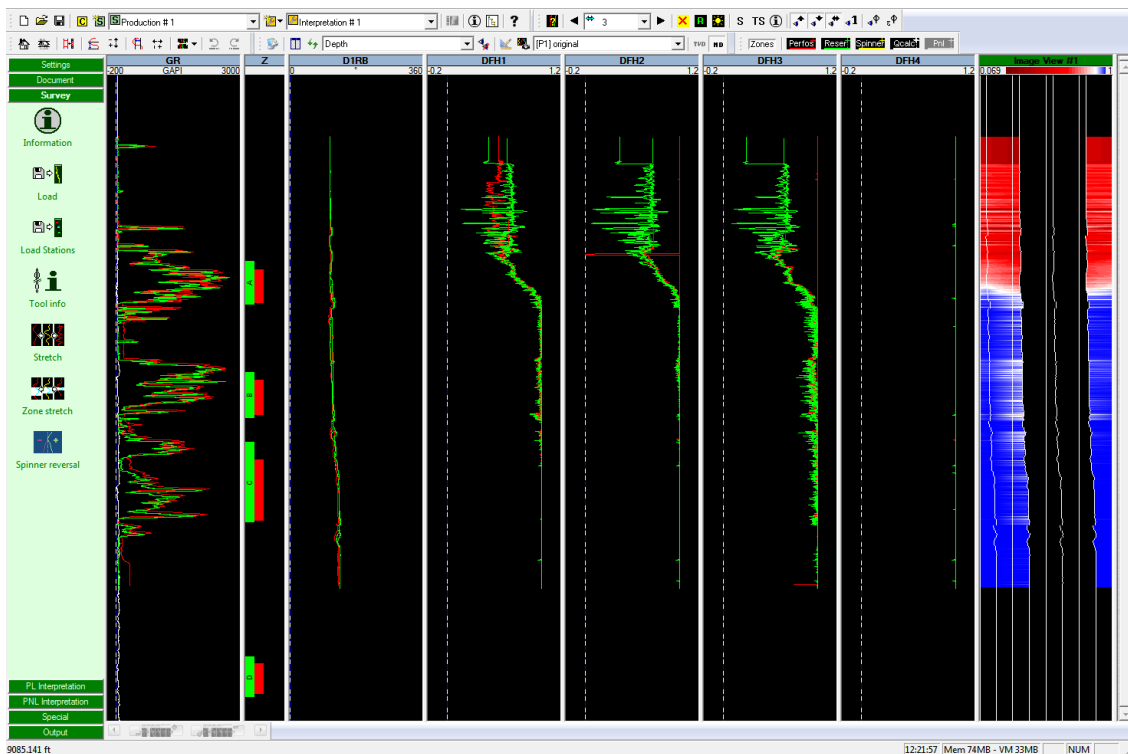

Fig. B05.14 • DFH4 status set to Disable

When the status is set to 'Ignore', interpolation occurs between the two neighbor probes Fig. B05.15.

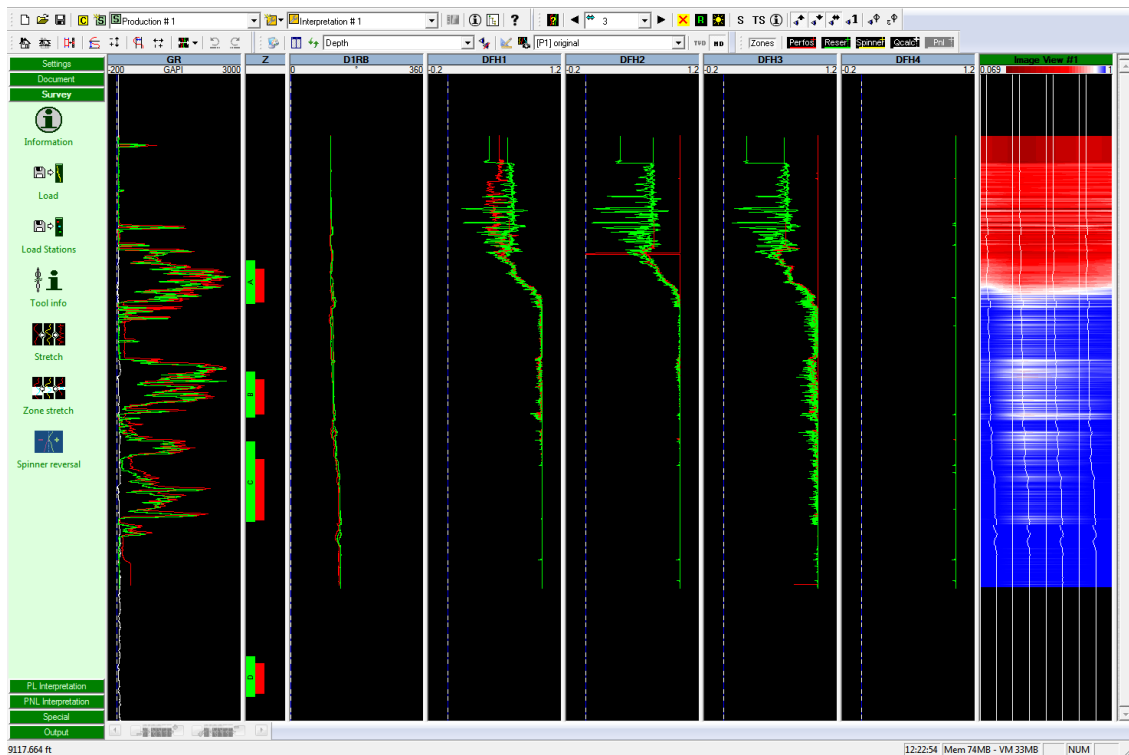

Fig. B05.15 • DFH4 status set to Ignore

B05.5.2 • Changing the color scale

- From the Image view 'Properties' dialog you can click on the 'Edit' button next to the Color Scale to access the dialog next page.

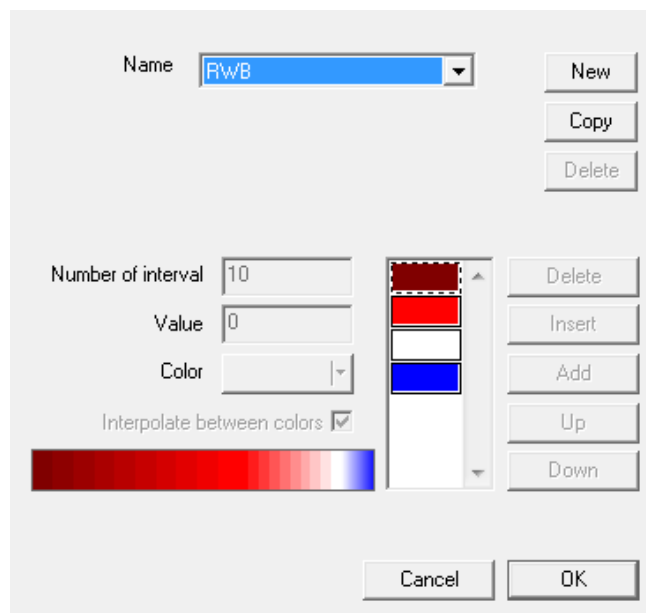















Fig. B05.16 • Color scale edition

Several color scales are predefined on a normalized range. These scales can be duplicated and the copy modified; new scales can also be created.

RWB	0		1
Blue	0		1
Rainbow	0		1
Rainbow Inverted	0		1
CAT Water-Air	0		1
CAT Air-Water	0		1
CAT RGB	0		1
CAT YRB	0		1
CAT YGB	0		1
CAT OGW	0		1
SAT	0		1
Green-Blue	0		1
Bubbles	0		1

For a given scale, one can add as many colors as desired, each color is associated with a given value, and the number of intervals between values is entered (used to interpolate between two successive colors/values). Non-linear color scales can thus be created where little changes near the bounds are highlighted. User-defined scales are saved in the registry and become accessible for any future session of Emeraude.



- Save the screen layout using the capture button . Add the new layout as DEFT1.

B05.5.3 • Image view for the second DEFT

Similar to what was done for DEFT1, images can be constructed for the second DEFT tool as well.

- Re-organize the screen to show the DEFT2 holdup and relative bearing channels: DFH5, DFH6, DFH7, DFH8, D1RB2, Fig. B05.18.

This time, the view templates will be used to create the DEFT2 image view. They contain predefined settings for some views (rate views, automatic views, user views and cumulative user views) and can be combined into full layout templates in order to organise Emeraude display. For the Schlumberger tools, a file located in the Emeraude application folder and called SchlumbergerTemplates.kvt can be used.

- Click on . The invoke view template window opens.
- Click on Edit. The Settings – Default Display window opens, the 'Templates' tab active.
- Click on  icon to add an existing template file to the list of available templates. Then browse to find the file SchlumbergerTemplates.kvt in Emeraude installation directory.

After loading, the SchlumbergerTemplates.kvt file now appears in the Settings – Default Display window.

- Close this window on OK.
- In the Invoke view template window, expand the Image views folder of the SchlumbergerTemplates and select 'FlowView Holdup'. Click OK.
- In the opened window, expand the file node, select pass down2, give a view title like 'DEFT2', check 'Use suffix' to add the survey short name and pass number to the view title, select tool DEFT 5-8 (DFHx) and click OK.

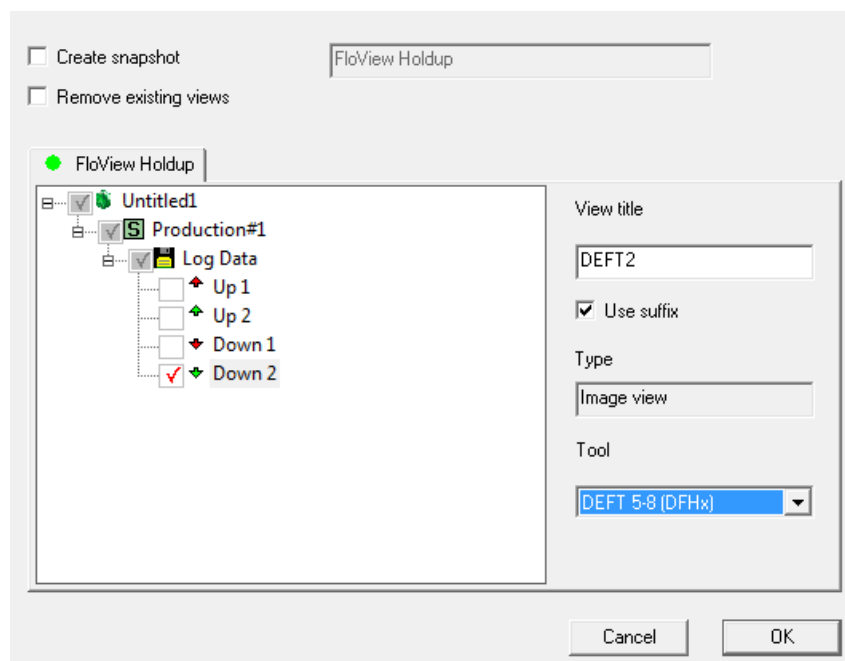

Fig. B05.17 • Image view creation from template

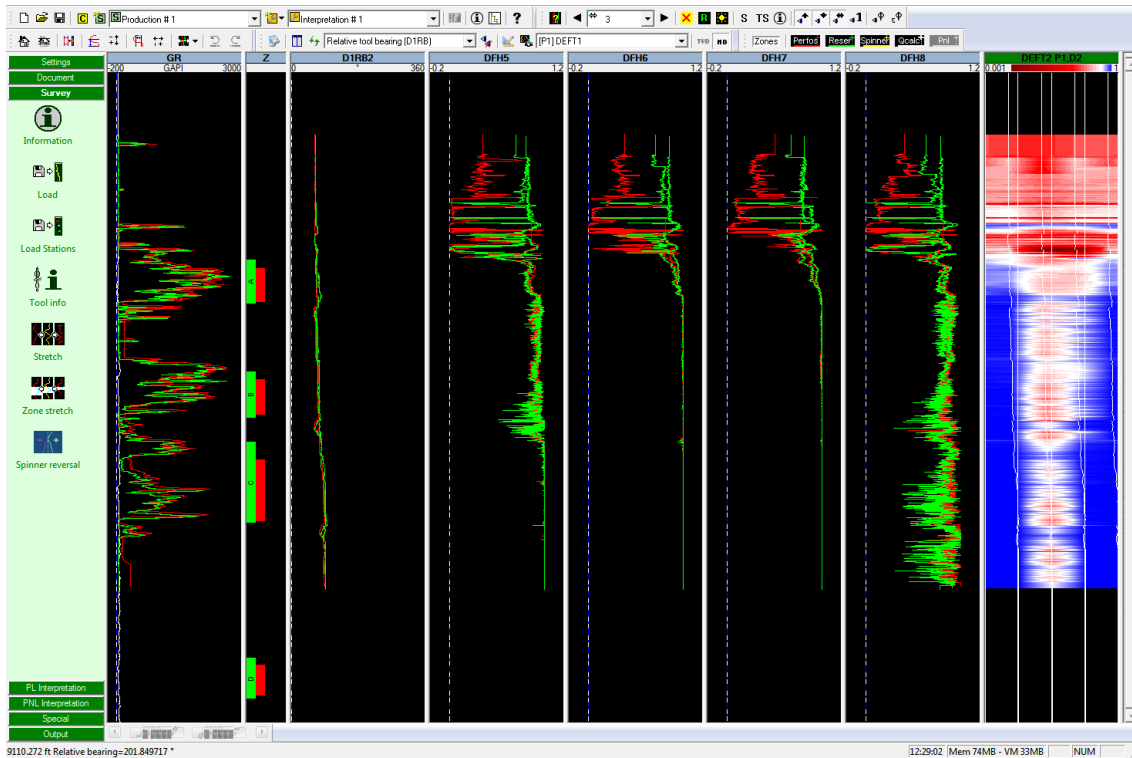

Fig. B05.18 • DEFT2

This new screen layout can be captured under the name DEFT2 for instance.

B05.5.4 • Combining both tool readings

A look at the values of relative tool bearing D1RB and D1RB2 in the data browser indicates that D1RB2 is equal to D1RB – 45. The dual tool configuration is thus as shown opposite. If the first probe of the dual tool is taken as DFH1, the tool bearing for that tool is D1RB.

Although a built-in tool matches this configuration (see 'PFCS-DEFT (DFHx)' in 'Settings' – 'Multiple Probe Tools'), for the sake of demonstration we will define a new tool that matches it:

- Go to 'Settings' – 'Multiple Probe Tools'.
- For the tool type select 'Holdup', then click on 'New' and call the new tool 'Dual DEFT'. Make sure the tool type is 'PFCS'.
- Set the number of probes to 8.
- Change the probe mnemonics in order to meet the relationship between probe index and mnemos according to Fig. B05.19 and Fig. B05.20, starting with DFH1.
- Set the relative tool bearing channel to D1RB, Fig. B05.20.

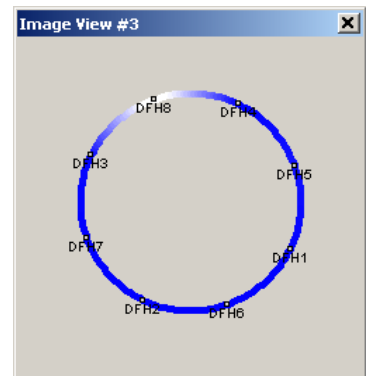

Fig. B05.19 • Dual tool configuration

The new tool defined at this level is added to the Windows Registry, and is available for future sessions of Emerald.

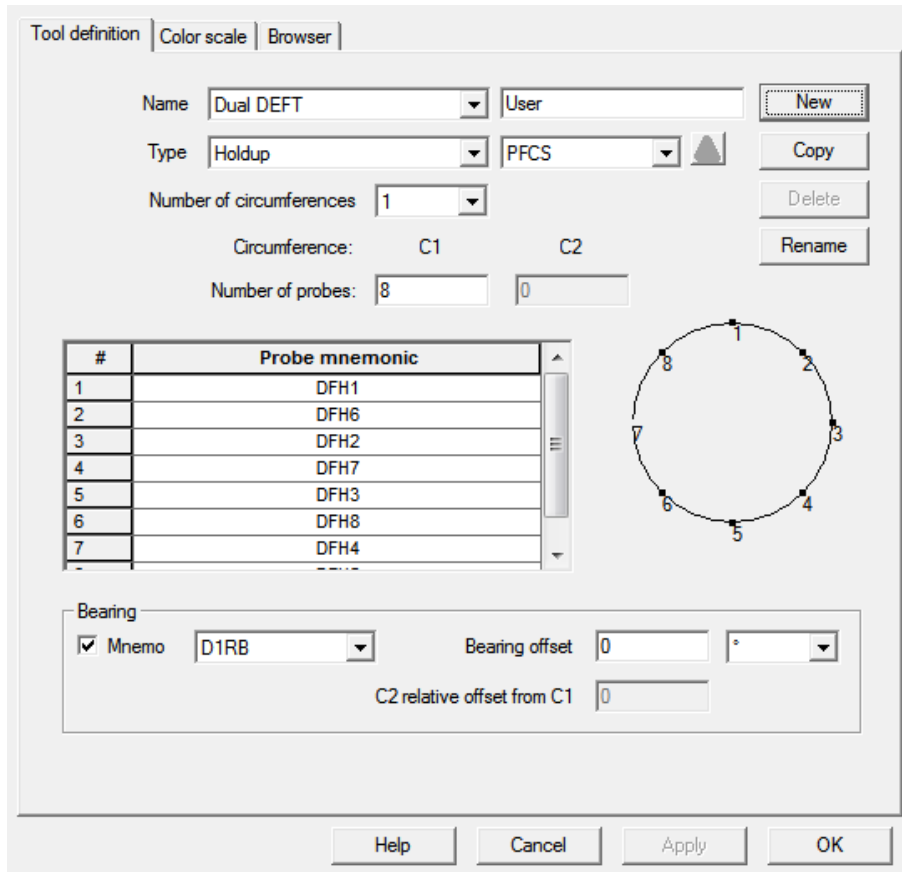

Fig. B05.20 • Dual DEFT definition

In the 'Multiple probe' tab of the 'Survey' – 'Tool Info' page, you will find the newly defined tool. The status for probe 7, i.e. DFH4, should be set to 'Ignore'.

- When this is done, create a composite image view for pass Down 2 using the new tool definition, Fig B05.21.
- Set the display to show DEFT1, DEFT2 and Dual DEFT image views, Fig. B05.21.

Note that image views can be renamed by a right click on the view and selecting the 'Properties' option. The name can also be changed in the data browser.

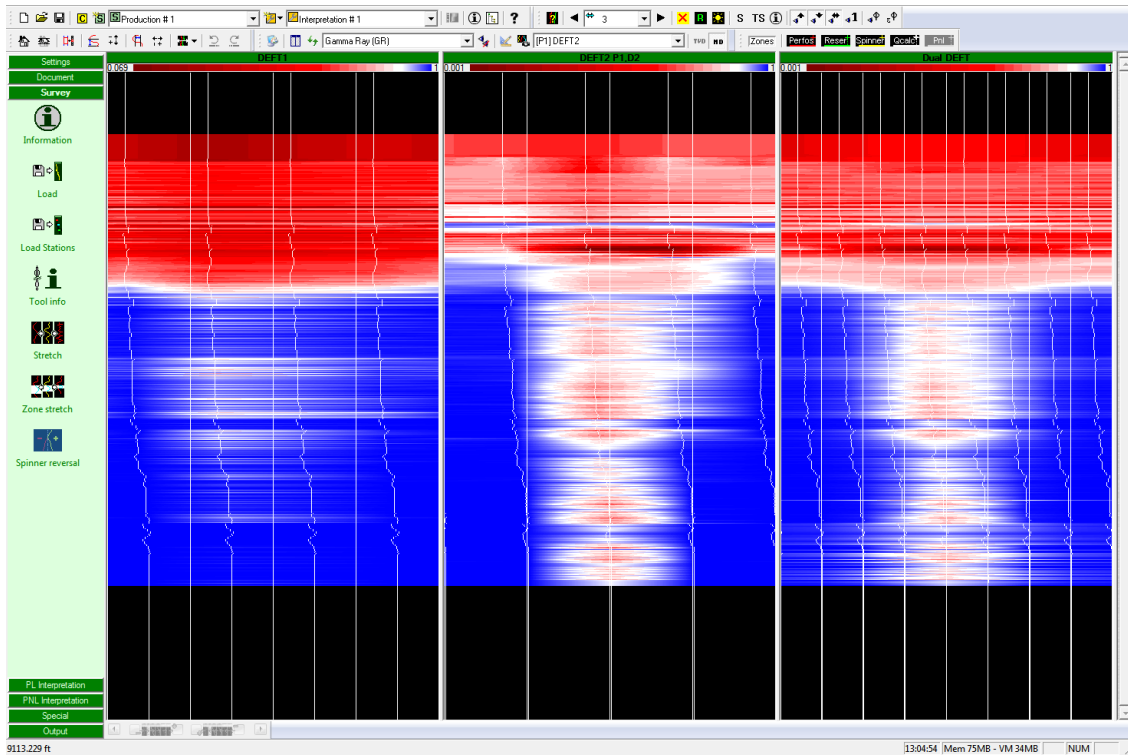

Fig. B05.21 • Image views for pass down2: DEFT1, DEFT2, and Dual DEFT

The dual image shows some discontinuities going from the reading of one tool to the other, which is expected when looking at the images for DEFT1 and DEFT2 next to each other.

Nevertheless, we will accept this difference as we will eventually average all the probe readings (except DFH4). We will see later in the interpretation if this assumption was valid.

Looking at the image alone it may be difficult to know the location of the various probes. This can be seen by a right click on the image view, and selecting the 'Cross-section' option. This option brings up the dialog shown below. With the dialog on the screen, if you press the 'Shift' key and move the mouse inside the image view, you will see a continuous update of the probe position and the interpolated holdup circumference.

Note: Access to the cross sections requires the definition of the geometric parameters, for the particular tool; this is entered in 'Multiple probe' tab of the 'Survey – Tool info'. Set all DEFT tools geometry identical: $L_p/L_a = 0.75$, $L_b = 0$, $L_c = 0$ and $ID_{max} = 11$ in.

The cross section will be drawn differently depending on the selected average holdup calculation type:

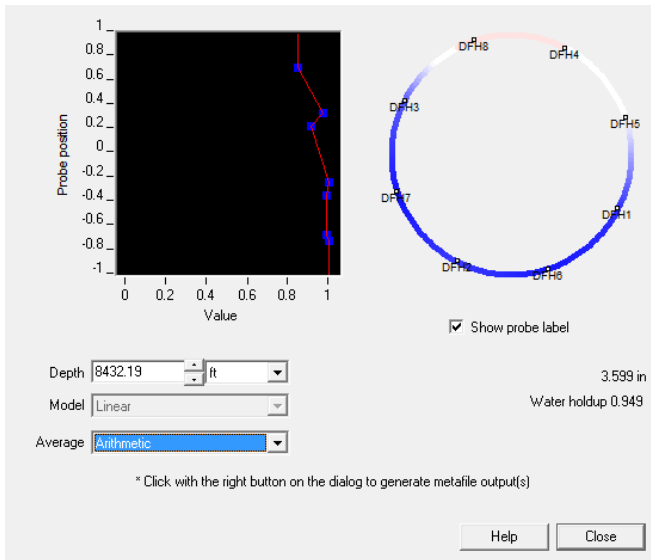

Fig. B05.22 • Arithmetic average holdup

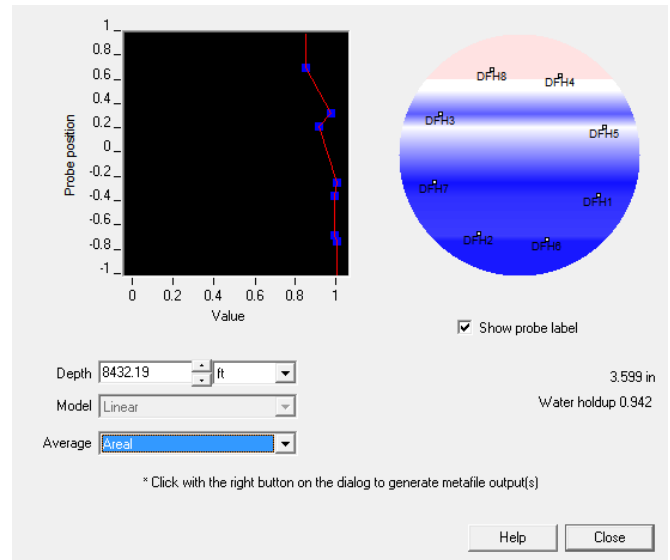

Fig. B05.23 • Areal average holdup

The plot on the left indicates the position of the probes (relative to the center of the tool) and their values (symbols), and the associated model used to represent the probe measurements across the section (here Linear represented by the red line). You can experiment with the 'MapFlo' model, dedicated to Schlumberger holdup tools, which ensures vertical stratification.

B05.6 • Interpretation

The interpretation will be based on the following:

- Vapp as calculated from the spinner.
- VW stations.
- Water holdup, calculated using the two DEFT measurements.
- dPdZ, pressure derivative.

When the reference channels are built, Emerade will add reference and match views automatically. In order to make some room for those views, you can hide all tracks except the depth, Gamma ray and Z tracks. For the purpose of spinner calibration, bring the SPIN and SCVL tracks on the screen, as well as the caliper C1C2 track.

The dPdZ channels need to be built. This can be done in one go for all passes:

- Inside the browser, click on the pressure channel for one pass,
- Select the 'Derivative' option (right click or **f'** button).
- Enter a smoothing of say 12ft and click on the 'Log Data' node to in the tree view: this selects all child nodes onto which the same processing will be applied.

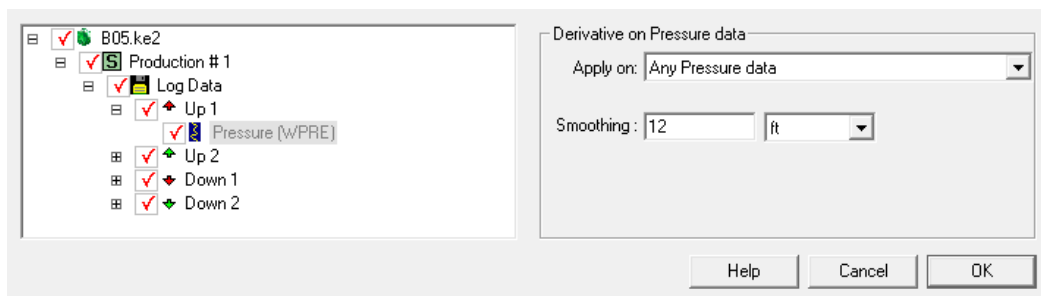

Fig. B05.24 • Pressure derivative for all passes

B05.6.1 • Reference channel construction

- Create a new Interpretation, accept all defaults and OK for the time being.

Vapp

- In our interpretation we define 4 'Calibration zones':

Calibration zones (ft)

8110	8130
8359	8394
8566	8579
8796	8821

You may either enter the above values in the grid directly (Use the 'Zones' button of the zone toolbar), or double-click in the Z track to access the same dialog. You can also select the 'Interactive' definition. In this case, you will need to call the option in turn for each zone. Fig. B05.25. illustrates the choice of calibration zones. The top calibration zone lies in a section not covered by pass Up1. One could move this zone closer to the perforation where Up1 is still valid, but it would then encounter short caliper changes, which would render the calibration on that zone difficult.

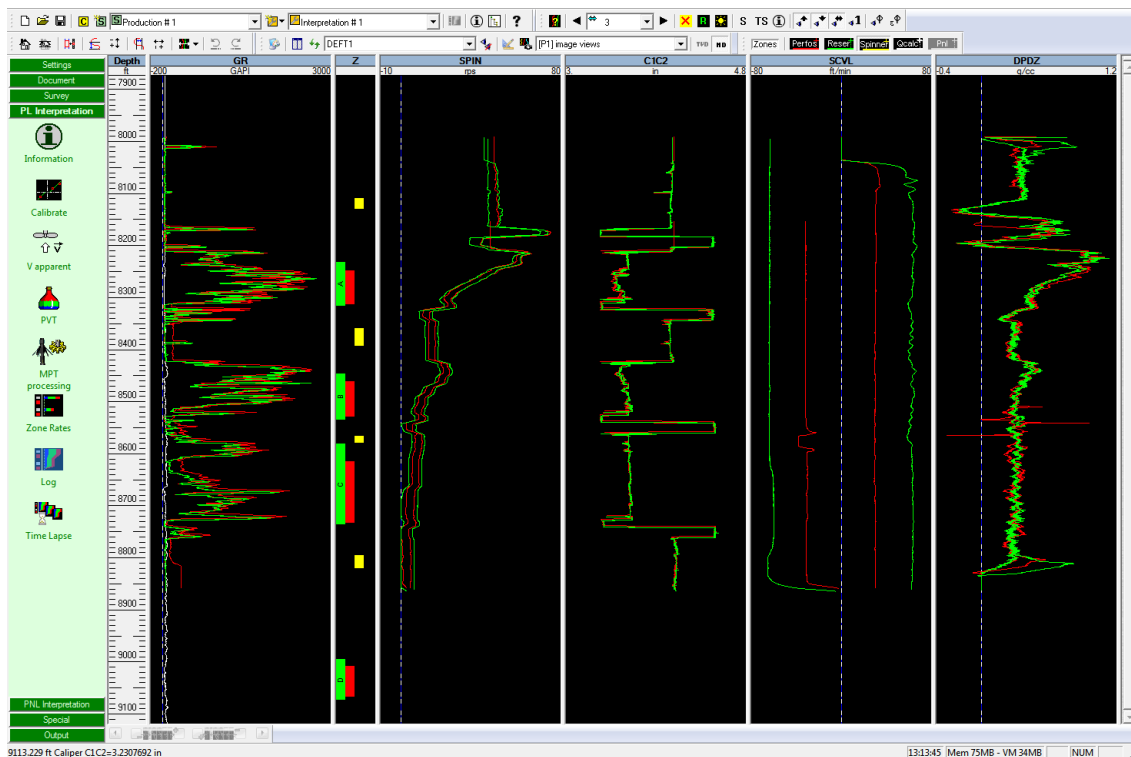

Fig. B05.25 • Spinner calibration zones defined.

Note that an Application setting (in 'Misc' tab) allows keeping active the interactive zone creation mode after the first call. This can be of great help when defining reservoir zones in multilayer situations, for instance.

- Select 'Calibrate' and accept the automatic calibration, Fig. B05.26.

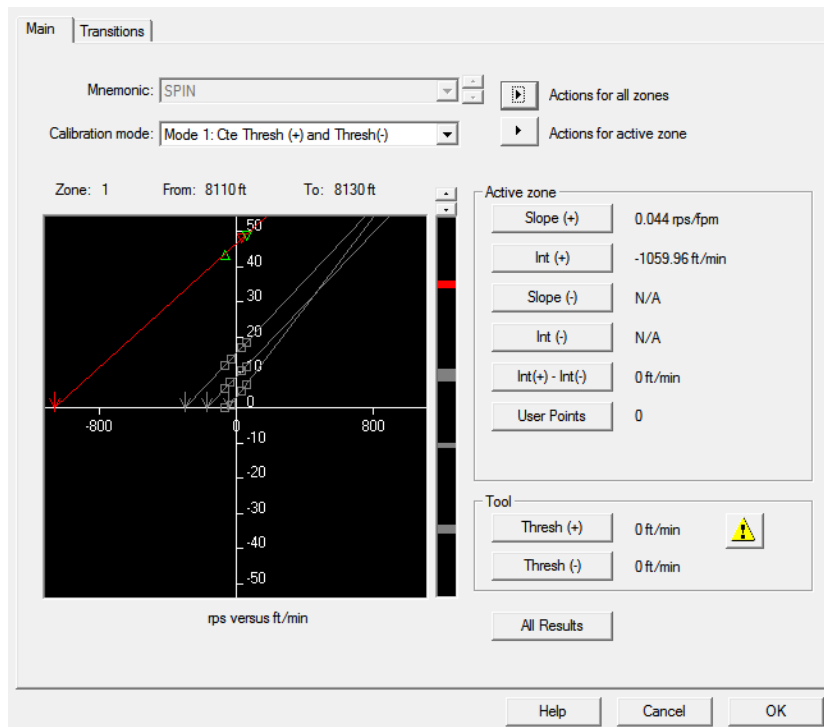

Fig. B05.26 • Spinner calibration

In the 'Vapp log settings' dialog:

- Leave all the weights to their defaults, ensure that 'Keep Vapp for each pass' is checked, and validate to generate the Vapp channels. Note that each pass apparent velocity is stored in the 'Calculated log data' node, under the interpretation node, and are visible in a dedicated automatic view. This is meant to ease at controlling data quality.
- Go to 'PL Interpretation' – 'Information'.

A red warning indicates that the interpretation finds no Internal Diameter. We will resolve this later.

Temperature/Pressure

- Select 'Define' and use the channel of pass Down 1 for both.

Density

- 'Define' the pseudo density channel as the one of pass Down 2 for instance.

VW: water velocity

- Click on the 'Define' button for water velocity.
- Set the mode to 'Merge' and the list of available stations is displayed in the list below.
- Select 'All' available stations by clicking on the node 'Stations', Fig. B05.27.

The Merge algorithm constructs a single channel containing a lateral average of the values present at each station. This resulting channel has absent values between every valid point and it will be displayed as a set of discrete points on the views. No interpolation is ever done between the values, so in particular, this channel cannot be used as part of a complete log calculation.

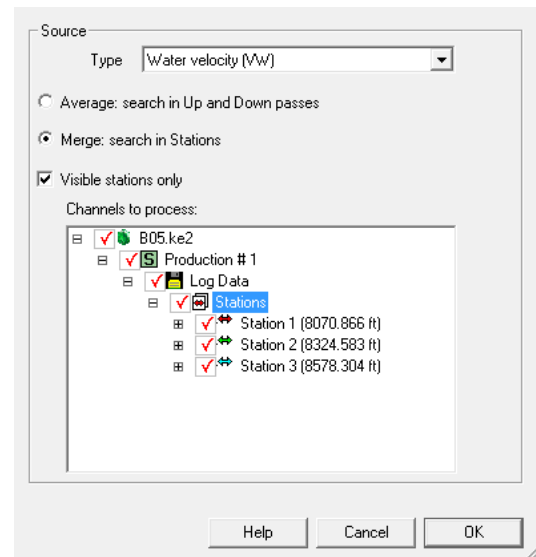

Fig. B05.27 • Stations selection

- Leave the 'Interpretation Settings' dialog with OK.

Water holdup

The water holdup will be calculated using the MPT processing; we do not want to directly select discrete measurements in this option.

Caliper

The caliper channels are present in the log passes only. It is necessary to add a caliper channel inside the Interpretation. This can be done by drag-and-drop or with the 'average' option.

- Open the data browser.
- Select the node 'Interpretation#1'.
- Activate the 'List' tab on the right, where you will see the content of the Interpretation (Input, Output – Complete, Output – Schematic).
- In the data tree, move up and open the Down2 node in the Log Data folder.
- You can then drag the C1C2 channel and drop it on the right, Fig. B05.28. *Using the 'List' tab you do not need to keep the Interpretation node visible on the left.*

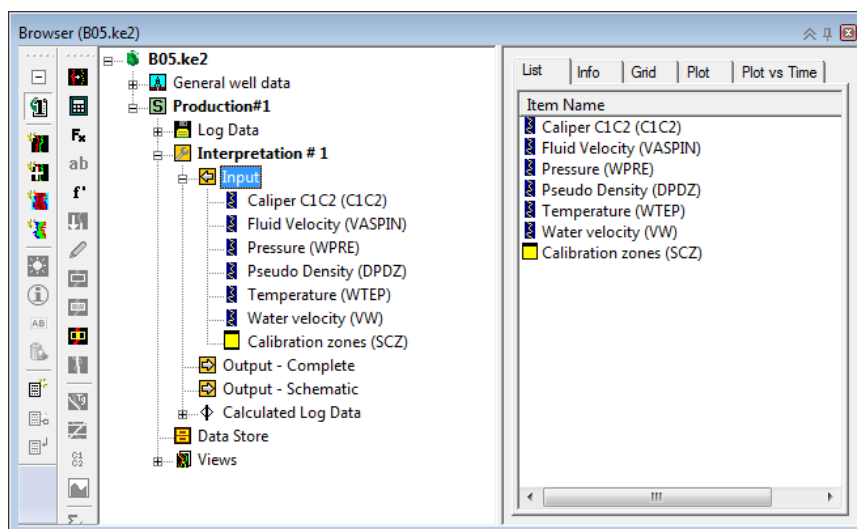



Fig. B05.28 • Data browser

B05.6.2 • PVT

The PVT is available in the B05.epv file.

- Click the 'PVT' icon of the 'Interpretation' panel.
- Select  to load this file.
- Scan through the properties of the various phases in order.

You will see that most parameters have been matched to measured values:

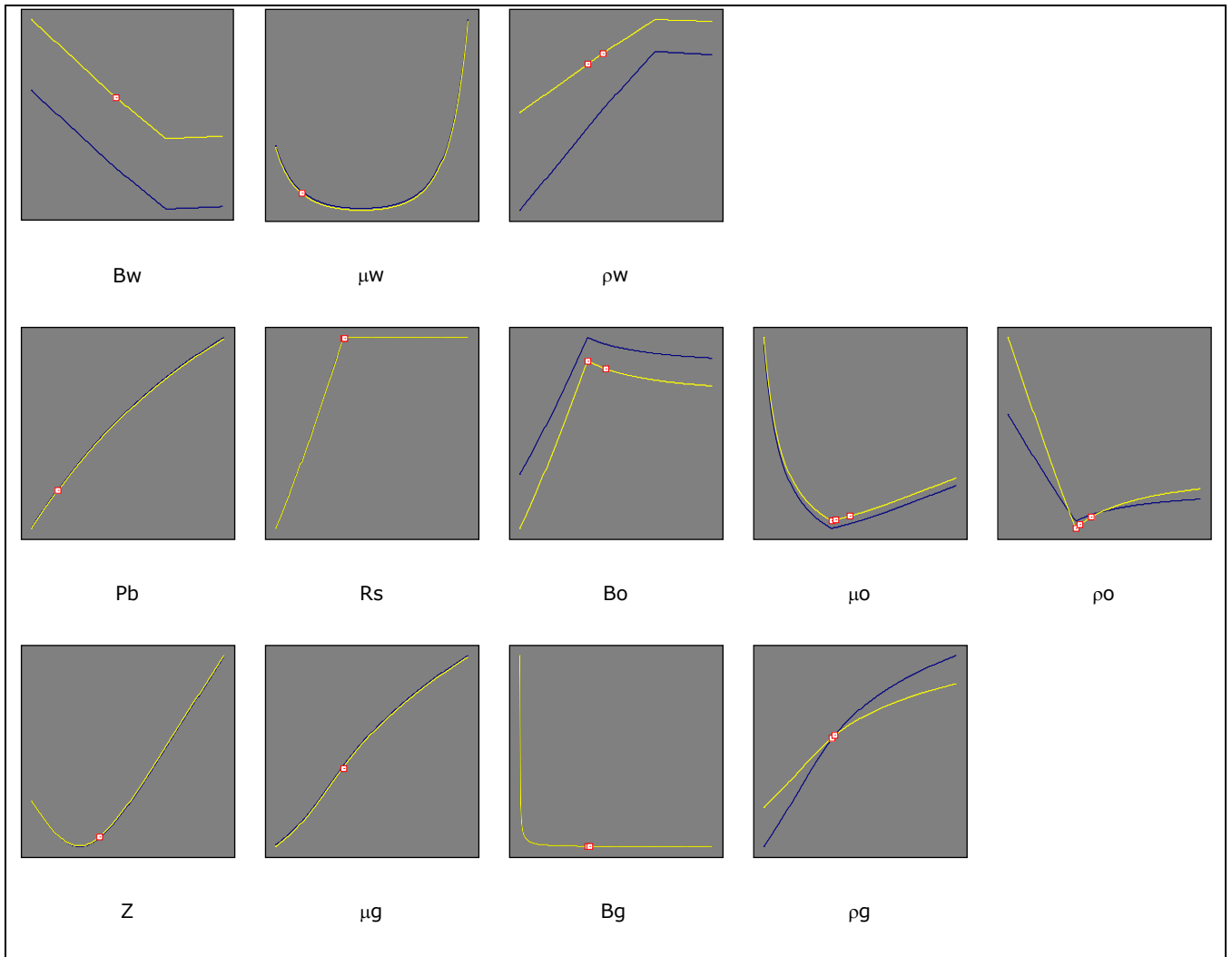

Fig. B05.29 • PVT constraints

B05.6.3 • MPT processing

In the present case, the objective of the MPT processing is to calculate at every depth an average value of water holdup from the discrete measurements. This is performed by matching the probe measurements with a 2D model representing the distribution of holdup. The matching can include external constraints. With the knowledge of the holdups everywhere at each depth, an integration is made over the entire cross-section to get the desired average.

In the PL Interpretation panel, click on the MPT processing button. The MPT processing window opens in which the following choices are done:

- Set the Tool type: Dual DEFT.
- For the 2Dmodel select: MapFlo Holdups.
- Use for Input: Independent passes Down2 and Up2.
- Check 'Average of the outputs'.
- Leave the other choices as per default.
- Press OK.

A message indicates that the processing will generate more than 200 points. This limitation is meant to avoid heavy processing on slow computers, but you can change or remove it by visiting the control panel Settings Interpretation option ('Maximum number of output depths' in the Misc tab).

- Press OK.

The results of the MPT processing (reconstructed data, errors and averages) are stored within the interpretation where the process was launched. They can be accessed via the browser and are displayed in automatic views.

In the browser, below the interpretation node, the 'Calculated Log Data' node gathers the results of each pass included in the MPT process, as shown in Fig B0.30.

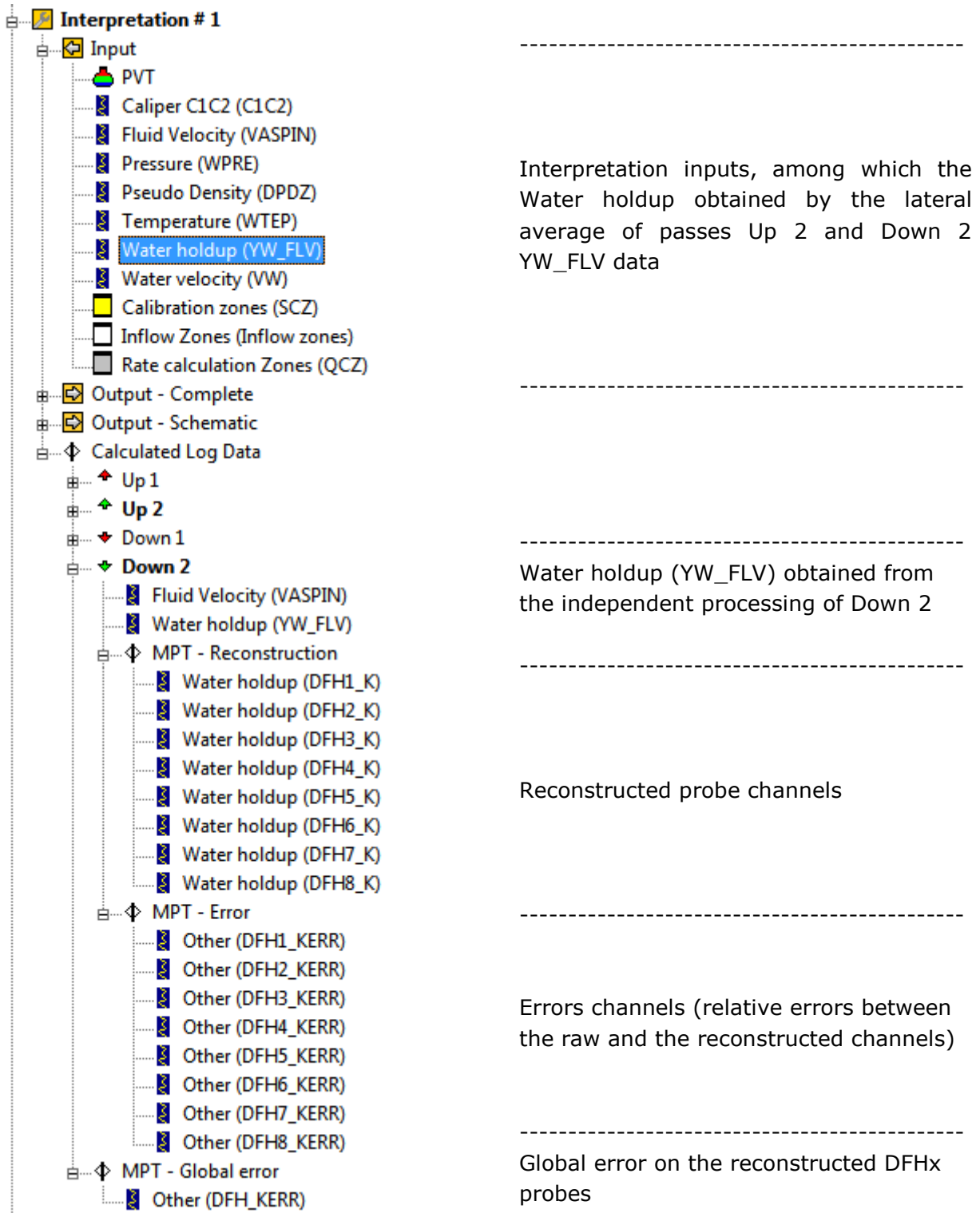

Fig. B05.30 • Browser tree.

Detailed information about the MPT processing is available in Guided session #8 for the Schlumberger FSI, and in Guided session #9 for the Sondex MAPS.

At the end of the process, an automatic view called 'YW_FLV' is added. It contains the average water holdup from the processing of the Dual DEFT: the YW_FLV curve from the Interpretation input as requested (in white) and the 2 YW_FLV generated (reconstructed) by the independent MPT processing for passes Up 2 and Down 2. There is also a track called 'MPT errors I1' which shows the arithmetic average of passes Up 2 and Down 2 relative errors (e.g. average of the DFHx_KERR data). Above 8300 ft, the error curve deviates slightly from 0, indicating that the reconstructed data differ from the raw data. As reference channels are built, the corresponding match views are created.

You can setup the screen as in Fig. B05.31.

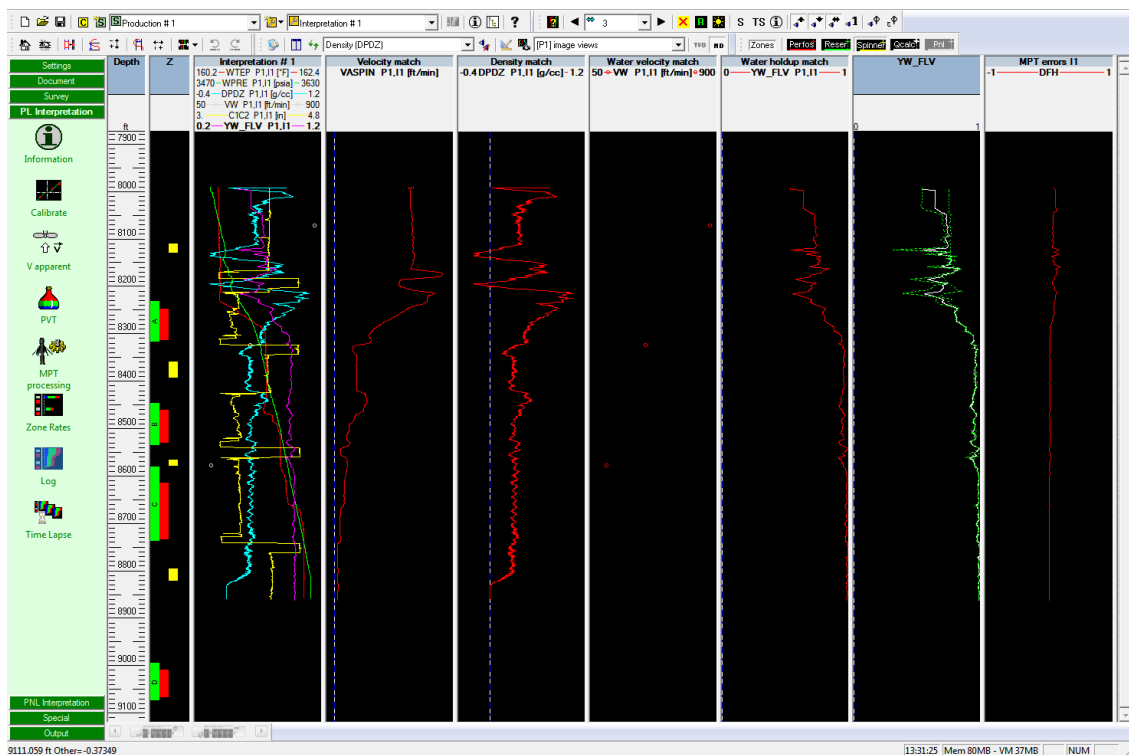

Fig. B05.31 • Reference channels and match views.

B05.6.4 • Zone Rates

In order to use the VW information it is necessary that the stations be included inside calculation zones.

- Select the 'Calculation zones' options, and 'Interactive zone definition'.
- Create a first calculation zone to include the top station.
- Select the 'Calculation zones' option in turn to create zones 2 and 3 for stations 2 and 3, zone 4 below the third set of perforations, and a final zone below the fourth perforation, as in Fig. B05.32.

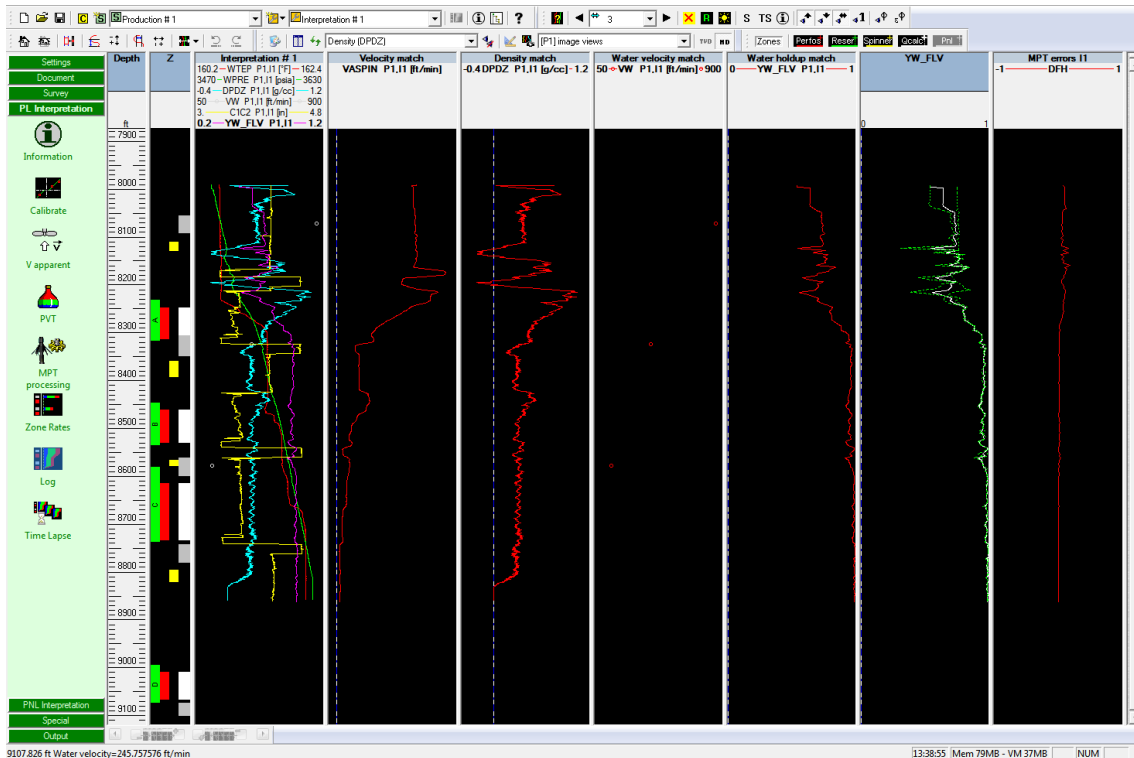

Fig. B05.32 • Calculation zones created

- Select 'Zone Rates'. The default model is 3-Phase L-G.
- Select 'Petlas & Aziz' for the Liquid-Gas slippage, and 'ABB-Deviated' for Water-Oil.
- In the 'Rate calculation' tab, on the first 3 zones,
- Check that:
 - the regression is using Vapp, Density, YW, and VW, Fig. B05.33.
 - VW is not available on the bottom 2 zones.

On the lowermost zone, no measurement is available but Vm can be set to 0 manually, which will permit that the schematic does not stop at the last data point, and will thus allow Emerade to calculate contributions for all perforations. This should be done automatically.

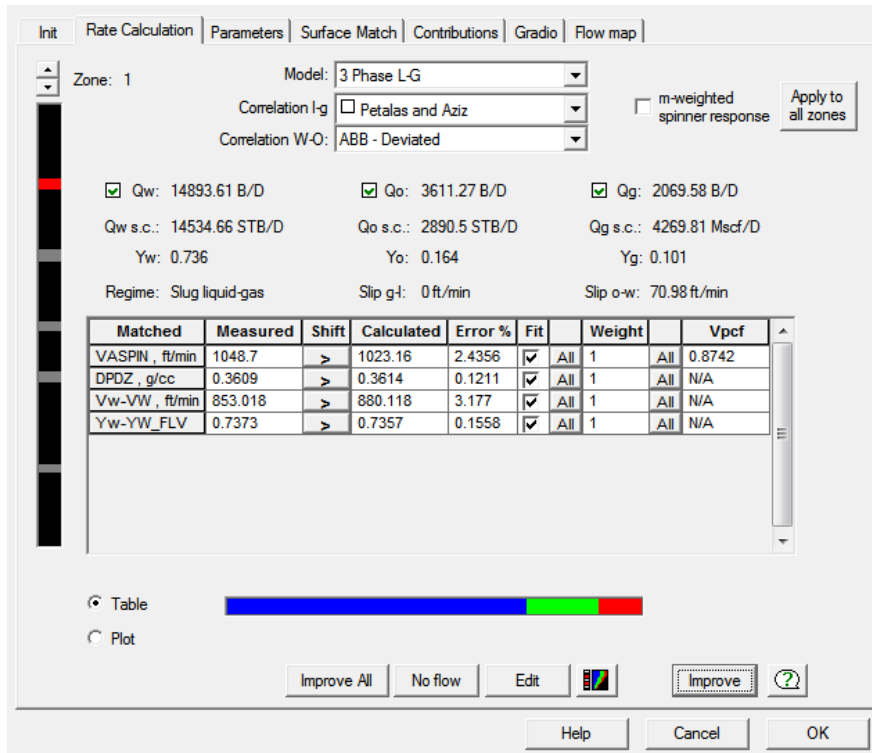

Fig. B05.33 • Zone Rates

- Validate the Zone Rates results and generate the schematic logs down to 9100 ft, Fig. B05.34.

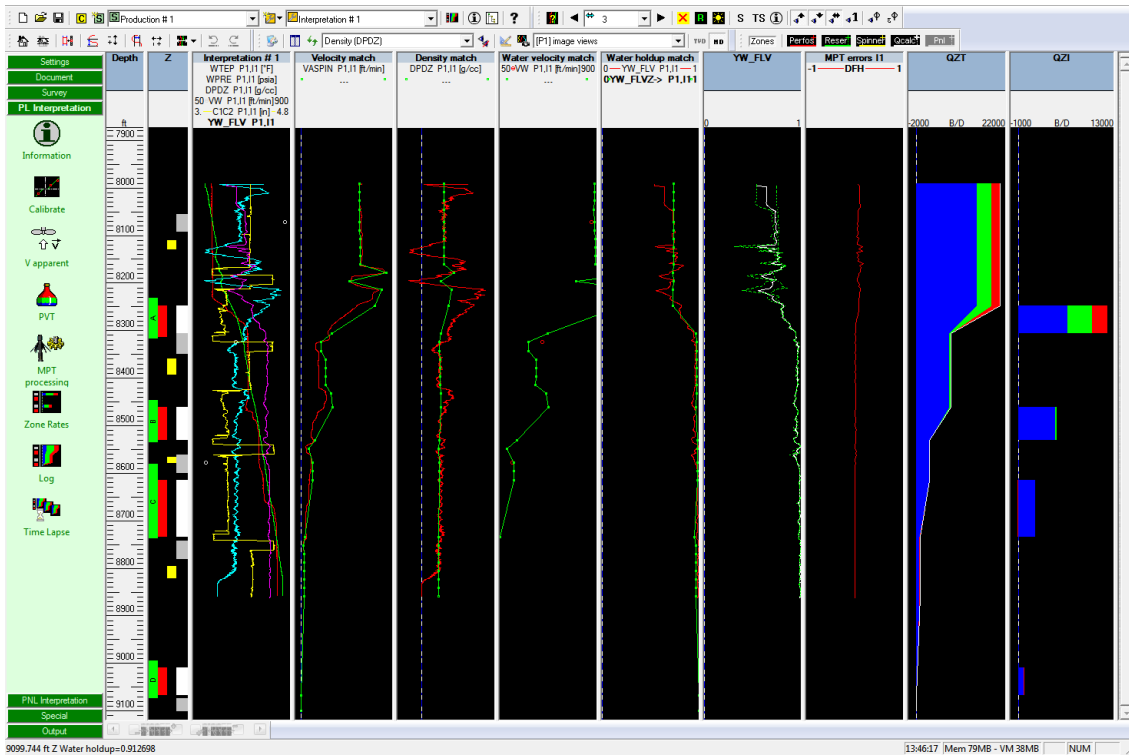

Fig. B05.34 • Schematic generated

Overall, there is a fair agreement between measured and simulated data, even though the problem is over-specified and the slippage velocities are estimated using correlations. We could in fact let Emerade infer slippage velocities from the measurements.

On the top zone, there are 3 unknowns, and 4 measurements including a direct velocity, so we can change the Liquid-Gas slippage. On the middle 3 zones, we can switch to a Water-Hydrocarbon model and change the Water-Oil slippage. This can be achieved in the following manner:

- Go to 'Zone Rates':
- For the top zone set the correlation L-G to 'Cte slippage'.
- For the next three zones, set the Model to 'Water-Hydrocarbons (L)' and the correlation to 'Cte slippage'.
- Run Improve All.

On zones where the slippage is inferred from measurements you will see a checked box in front of 'Slip hc-w'. On zones using the Water-Hydrocarbons model, the value of F_g is displayed in the results table in red. This is to indicate that this residual is based on the PVT, not on the measurements. Validate to update the schematic logs. A slightly better agreement can be seen, in particular at the top of the log, see B05.35.

B05.6.5 • Complete Rate

Generate the complete rate log with a 2 ft depth increment, Fig. B05.35.

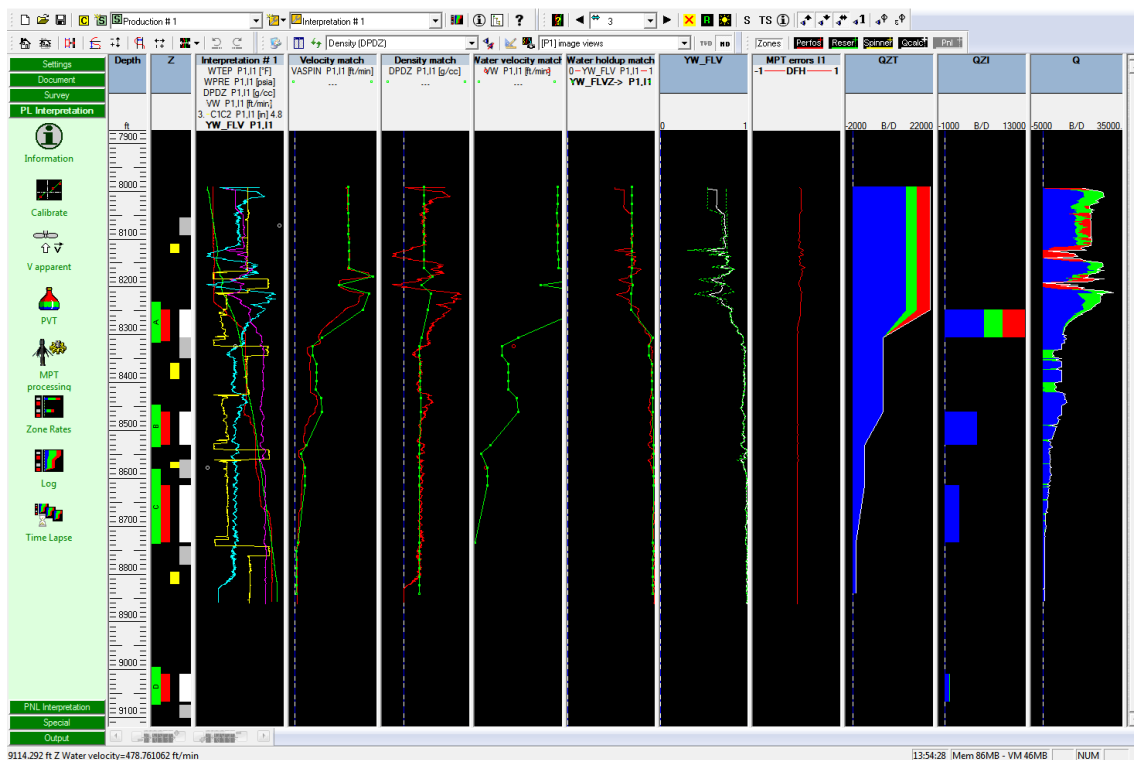

Fig. B05.35 • Complete logs generated

Unlike the schematic log, the complete log is not making use of VW. The complete log is based only on VAPP, YW, and DPDZ. The consequence is that for the top section of the log, the slippage velocity cannot be considered a variable during the regression. The value found on the top calculation zone is used.

On the above figure, one can see two well-defined intervals at the top where the solution produces a very small velocity and mostly gas. This corresponds to regions where the density is exhibiting two sharp peaks. Recall that this density was generated from the pressure derivative in a highly deviated well.... Furthermore, the significant diameter changes in this region may impact the pressure differential dramatically. Besides, the DEFT measurements do also exhibit erratic response in the same region. Overall, the density is the most affected and it is causing the erroneous complete log. One possible way of correcting the log would be to interactively edit the reference density. Another might be to give it less weight to density in the solution, at least for the interval corresponding to the top 2 calculation zones. But since we are in 3-phase the density will still affect the solution.

In 'Zone Rates', 'Rate calculation' tab:

- Set the weight for the density to 0.1 on zones 1 & 2.
- Leave the Zone Rates solution unchanged.
- Exit with OK. Re-generate the complete log, Fig. B05.36.

The Complete logs look a bit better but certainly not in full agreement with our schematics. The Complete logs are nevertheless not a representation of our diagnostic; we will keep them only to illustrate the Well view facility in the next section.

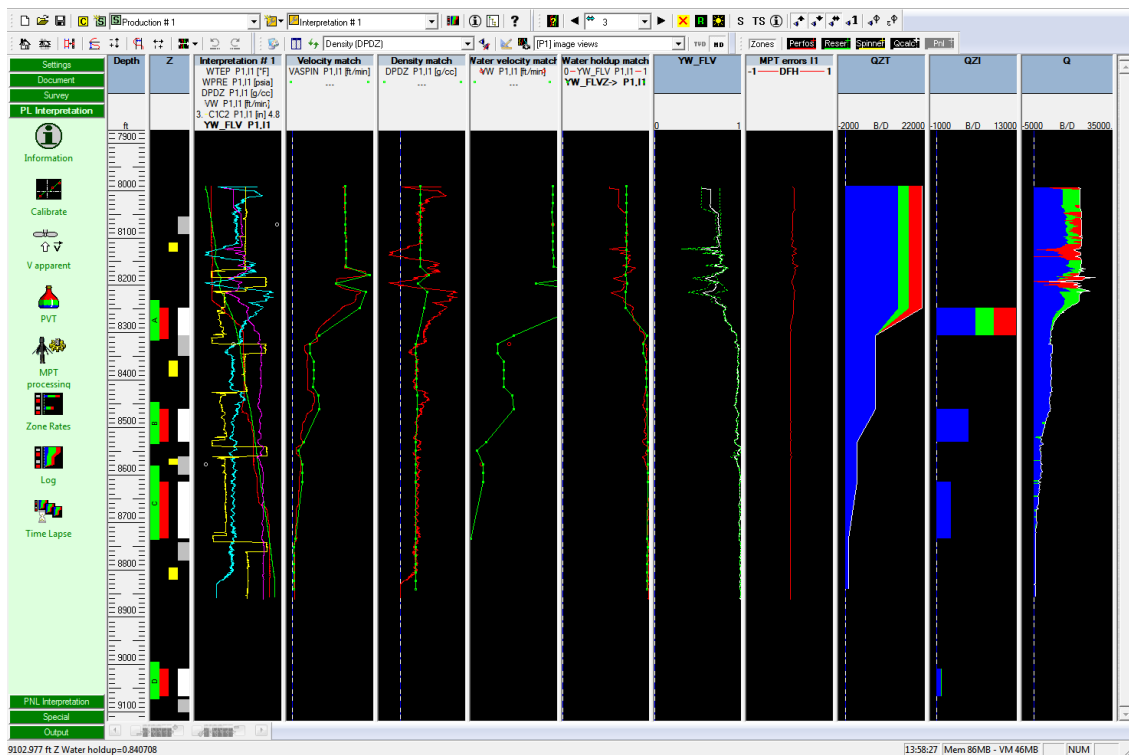



Fig. B05.36 • Complete logs re-generated

B05.7 • Result presentation

In addition to the rate and image views, well views can be created to show the wellbore geometry together with the continuous holdup curves. Inside the browser:

Inside the browser:

- Select 'Create well view' or .

The well view property dialog appears, Fig. B05.37:

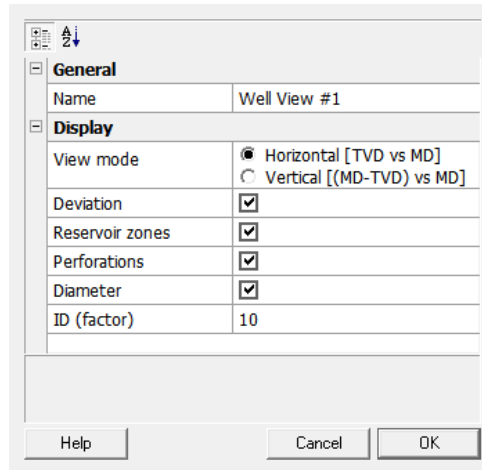

Fig. B05.37 • Well view creation

The well view can display the wellbore geometry from a deviation or a TVD channel. The wellbore schematic can also indicate the diameter changes. The view mode should be selected based on the well overall trajectory. If the well is near horizontal then the default 'Horizontal' mode should be kept. For a near vertical well, select 'Vertical instead'.

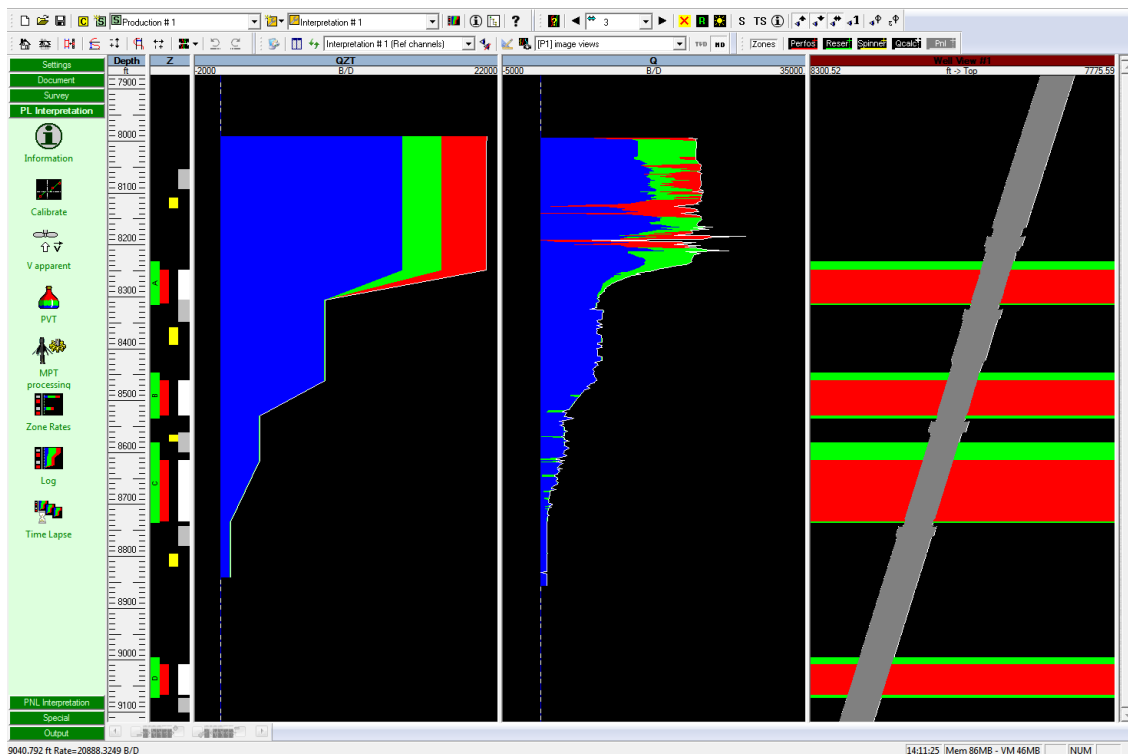

Fig. B05.38 • Well view with default settings

The following modifications can be brought to the well view:

Adding holdups

You can drop continuous holdup channels on the well view. For instance, drag and drop the YG, YO, and YW channels from the 'Output – Complete' node of the Interpretation onto the view.

Changing aspects

With a right click on the well view you can return to the 'Properties' dialog where a second tab, labelled 'Fill area' is present:

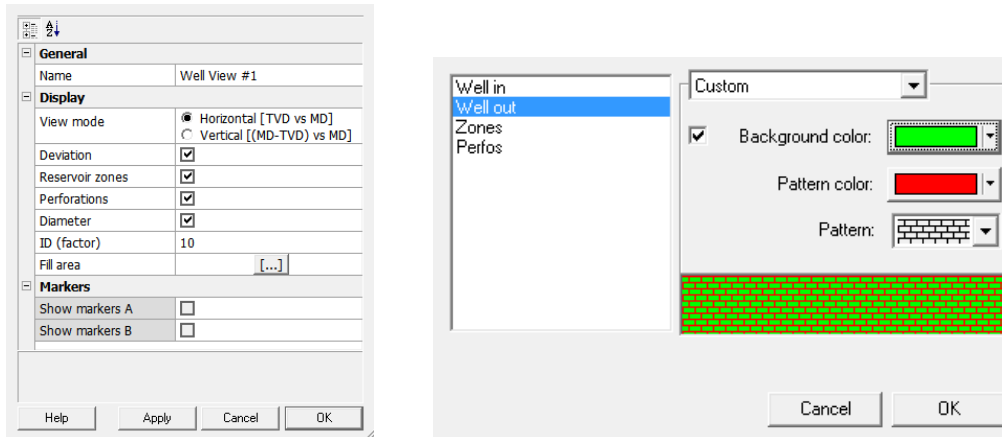

Fig. B05.39 • Well View Properties dialog and Fill area dialog

You can use this dialog to redefine the aspect of the zones outside, inside the wellbore. You can also modify the color of reservoir/perfos. Note that the later change will apply to the Z track too.

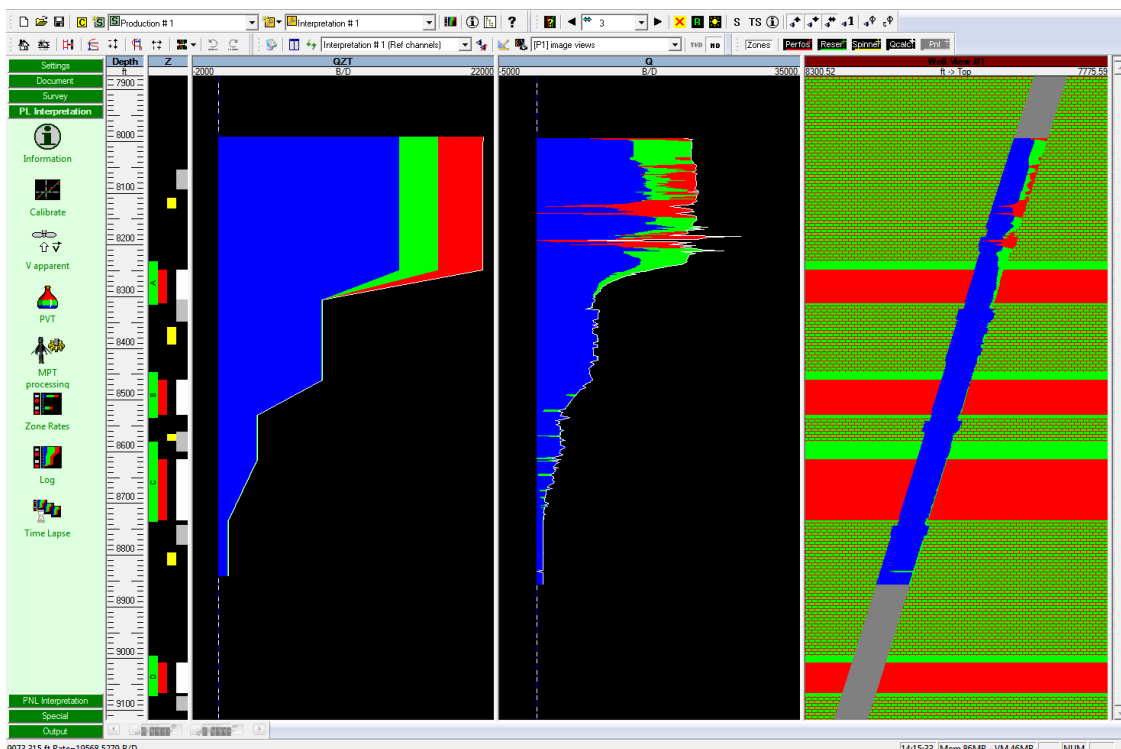

Fig. B05.40 • Final layout with modified well view

This concludes Guided Interpretation #5.

*Mark of Schlumberger