



# TRAINEE ASSESSMENT

IMAN ZULHILMI B ZAKARIA





1. HSSE

2. SLICKLINE

3. DOWNHOLE TOOL

- BASIC TOOLSTRING
- PULLING TOOLS
- SERVICE TOOLS

4. PRESSURE CONTROL EQUIPMENT

5. SURFACE EQUIPMENT

6. CONCLUSION

7. JOB SUMMARY

8. Q AND A

---

1. HSSE
2. SLICKLINE
3. DOWNHOLE TOOL
  - BASIC TOOLSTRING
  - PULLING TOOLS
  - SERVICE TOOLS
4. PRESSURE CONTROL EQUIPMENT
5. SURFACE EQUIPMENT
6. CONCLUSION
7. JOB SUMMARY
8. Q AND A

---

# Safety Policy

- **DB Management is committed to:**
- **Safety and Health:** Promoting a safe and healthy workplace for all employees.
- **Environmental Sustainability:** Conducting business operations in an environmentally responsible manner.
- **Specific Policies:**
  1. **Driving Policy**
  2. **Drugs & Alcohol Policy**
  3. **Harassment in the Workplace Policy**
  4. **HSSE Policy**
  5. **PPE Policy**
  6. **Smoking & Vaping Policy**
  7. **Stop Work Policy**





# GOLDEN RULES

---

## Golden Safety Rules

- Golden safety rules are essential for preventing accidents and injuries in the workplace.

1. Personal Ownership of Safety
2. Stop Work
3. Risk Assessment
4. Management of Change
5. Full Compliance of PPE
6. Working at Height
7. Lifting Operations
8. Approved PTW
9. Operate Vehicles Safely
10. Avoid Position in the Line of Fire

# Personal Protection Equipment (PPE)

1. Coverall
2. Hard Hat
3. Ear Plug
4. Safety Glasses
5. Gloves
6. Safety Boot

---

## 6 BASIC PPE FOR OIL & GAS WORKERS



# Permit To Work (PTW)

- A PTW is a document that allows work to start only after safety measures are in place.
- When is a PTW needed?
  1. High-risk activities: Working in dangerous places (like heights, small spaces, or near electricity).
  2. Unusual tasks: Work that is not done often.
  3. Work by outside companies: When other companies do work on your site.



JOB STEP	DESCRIPTION OF JOB STEP	POTENTIAL HAZARD	POTENTIAL CONSEQUENCES	CONTROL BARRIERS	ACTION PARTY	RECOVERY BARRIERS	ACTION PARTY
1	Check Condition Diesel	<ul style="list-style-type: none"> <li>• Incorrect refueling method</li> </ul>	<ul style="list-style-type: none"> <li>• Spill oil</li> <li>• Sharp edge</li> </ul>	<ul style="list-style-type: none"> <li>• Wear rubber glove.</li> </ul>	wireline	Apply first aid and get medical assistance if the injuries are severe	wireline
2	Check diesel level in power pack and air compressor	<ul style="list-style-type: none"> <li>• Overheat and leaking oil</li> <li>• Hydrocarbon</li> <li>• Flammable liquid</li> </ul>	<ul style="list-style-type: none"> <li>• Hand injury</li> <li>• Broken equipment</li> </ul>	<ul style="list-style-type: none"> <li>• Standby P.D.C at work site</li> <li>• Grounding Cable</li> <li>• Wear rubber glove</li> </ul>	wireline	Medical treatment	wireline

# Job Hazard Analysis (JHA)

- A JHA is a way to find out what could go wrong in a job.
1. **Break down the job:** Divide the job into smaller parts.
  2. **Find the dangers:** Look for things that could hurt someone or damage things.
  3. **Make it safe:** Think of ways to stop these dangers from happening.

# Example JHA - Epoms

		<b>JOB HAZARD ANALYSIS [JHA] WORKSHEET</b>			
<b>JHA NO.</b>		<b>PTW NO</b>		<b>WORK PERMIT TYPE</b>	FW
<b>FACILITY :</b>		<b>LOCATION</b>	MAINDECK	<b>SPECIFIC WORKSTATION</b>	
<b>EQUIPMENT NO. :</b>		<b>WORK DESCRIPTION</b>	Perform <del>topup</del> diesel on wireline equipment		
<p><b>NOTE</b></p> <ol style="list-style-type: none"> <li>JHA shall be applicable for all work activities which requires PTW.</li> <li>The pre-prepared JHA and JHA prompters will be used as a reference/guide during the development of JHA.</li> <li>Personnel carrying out the work shall be fully familiar with the written Work/Operating Procedures developed for the job. The Work/Operating Procedures shall describe, in step-by-step instructions, the correct method of executing the specified work.</li> <li>Prior to commencement of work (after PTW has been approved), the task-specific JHA shall be discussed amongst all personnel involved in the execution; and requirements contained therein shall be fully understood and agreed by all involved personnel.</li> </ol>					

JOB STEP	DESCRIPTION OF JOB STEP	POTENTIAL HAZARD	POTENTIAL CONSEQUENCES	CONTROL BARRIERS	ACTION PARTY	RECOVERY BARRIERS	ACTION PARTY
1	Preparation for PTW	<ul style="list-style-type: none"> <li>Wrong job or task.</li> <li>To avoid clash of work at platform</li> <li>Incomplete detail of work.</li> </ul>	To avoid clash of work at platform	<ul style="list-style-type: none"> <li>PTW approval from in charge personal.</li> <li>Competent personal to conduct the operation.</li> <li>Inform to all crew on location and description of work</li> </ul>	wireline	Ensure all team member review <del>jha</del>	wireline
2	Pre Job Meeting	<ul style="list-style-type: none"> <li>Wrong job or task.</li> <li>To avoid clash of work at platform</li> <li>Conflict of work.</li> </ul>	Other parties are not aware where you are performing the job	<ul style="list-style-type: none"> <li>Inform to all crew on location</li> <li>Inform the hazard involved at place of work</li> </ul>	wireline	Ensure team member not miss toolbox meeting	wireline

# Slickline

---

- **Slickline** is a single-strand wire used in the oil and gas industry to deploy various tools into the wellbore for multiple purposes. Think of it as a long, flexible fishing line that can be lowered into a deep well.
- **Here are some common uses of slickline:**
  1. Well cleaning
  2. Sand control
  3. Valve maintenance
  4. Downhole tool retrieval
  5. Pressure testing
  6. Wireline logging



# Slickline Wire

---

- **Wireline Types and Sizes**

- **Wireline diameters:**

1. 0.092 inches
2. 0.108 inches
3. 0.125 inches
4. 0.140 inches (commonly used for fishing at Dimension Bid)
5. 0.160 inches

- **Types of wire:**

6. ZERON (100 HS Stainless Steel)
7. EIPS (Carbon Steel EIPS Grade)
8. ZAPP (SUPA 75 Alloy)

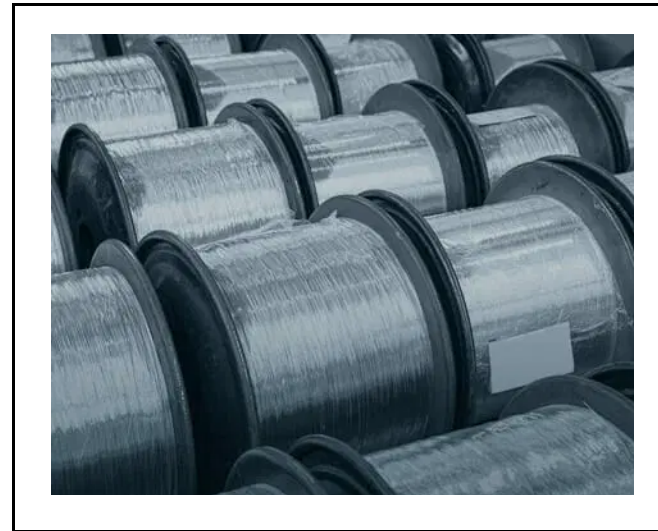

OPERATION
TCC (TUBING CLEARANCE CHECK) : Tubing Drift, Gauge Ring, LIB
Gas Lift Job (Retrieve & Set GLV/Dummy)

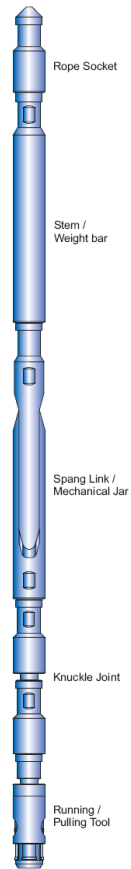

## Basic Tool String

1. Rope Socket
2. Swivel Joint
3. Stem
4. Knuckle Joint
5. Jar



Spring and Disc Type



Pear Drop Wedge Type



Braided Clamp Type

OD (in)	Fish Neck (in)
1"	1.000"
1.1/4"	1.187"
1.1/2"	1.375"
1.7/8"	1.750"
2.1/8"	1.750"
2.1/2"	2.313"

## Rope Socket<sub>1</sub>

- To attach the wire to the tools, we use these connectors:
  - Tear Drop:** Available in different sizes (0.108, 0.125, and 0.140 inches).
  - Regular Knot Type:** Used for 0.092-inch wire.
  - Braided Clamp:** Another type of connector.

## How to make up Rope Socket

- Get in the wire into rope socket and follow up by timber eye sleeve.
- Bend the wire 90-degree, measure wire with timber eye, bend the other side.



- Put the wire into timber eye, measure and cut the wire.
- Make sure wire fit on timber cross section.





- Put thimble eye into the timber sleeve.



# Done

□



# Swivel Joint

---

- **A swivel joint is a crucial component in slickline operations.** It serves as a mechanical device that allows rotation between connected components without twisting the wireline.
  - **Key functions of a swivel joint:**
    1. **Prevents wireline twisting**
    2. **Ensures smooth tool deployment and retrieval**
    3. **Improves operational efficiency**
    4. **Reduces the risk of accidents**
- 



O.D. (in.)	Fishneck O.D. (in.)
1.1/4	1.187
1.1/2	1.375
1.3/4	1.375
1.7/8	1.750
2.1/8	1.750
2.1/2	2.313

# Stem

---

- **A stem is a heavy steel rod that's connected to the tools.**
- **Adds weight:** It makes the tools go down into the well faster.
- **Keeps things straight:** It helps the tools stay in the right position.



OD (inc)	Weight lb/ft	Fishing Neck
1	2.5lbs	0.875"
1.1/4	4.2lbs	1.187"
1.1/2	6.0lbs	1.375"
1.7/8	9.4lbs	1.750"
2.1/8	12lbs	1.750"
2.1/2	16.7lbs	2.313"



## Knuckle Joint

- A knuckle joint is a special part that lets tools bend a little.
- It allows tools to move at a max 15-degree angle.
- This helps them fit in tight spaces or go around bends in the well.

---

## Jar

- **Jar** are tools that move up and down to hit things.
  - 20 or 30 stroke.
- There are different kinds: mechanical jars.



O.D. (in.)	Fishneck O.D. (in.)
1.1/4	1.187
1.1/2	1.375
1.7/8	1.750
2.1/8	1.750



## Downhole Tools Connection

1. Sucker Rod Thread
2. Quick Lock System
  - Shear pin Size
3. 1/8
4. 3/16
5. 1/4
6. 5/6
7. 3/8



# Pulling Tool

---

- Otis `S type (Jarring down to shear)
  - SB
  - SS
  - Otis `R type (Jarring up to shear)
  - RS
  - RB
  - Otis `GS (Jarring down to shear)
  - Otis `GR (Jarring up to shear)
- 

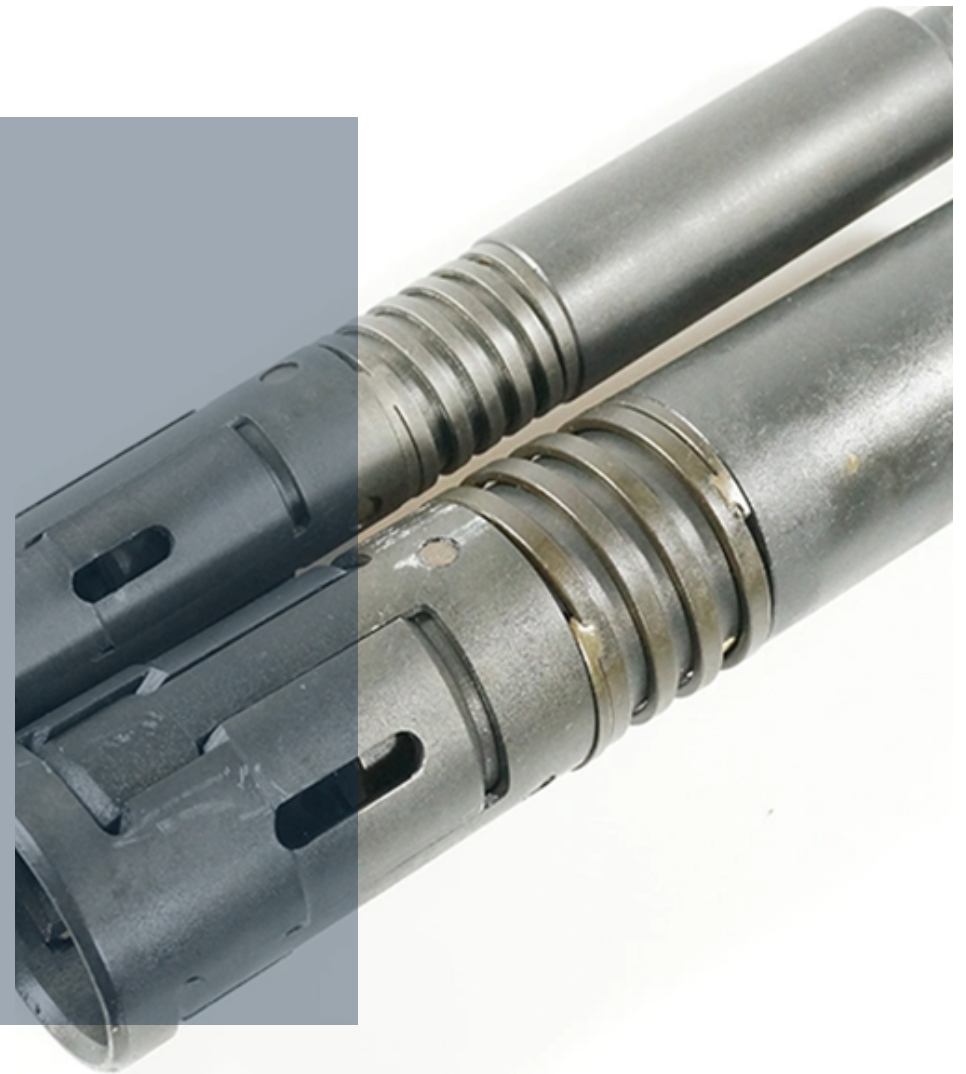

## OTIS `S Series Pulling tool

- S Series pulling tool used to engage an external fishing neck.
- SB (Long Core – Short Reach)
- SS (Short Core - Long Reach)
- Jarring down to shear pin.
- Top sub not attached directly to core.



Tool Size (in)	Fishing Neck (in)	Pulls F/Neck
1.1/2 SB	1.187"	1.187"
2 SB	1.375"	1.375"
2.1/2" SB	1.375"	1.750

# OTIS S' Series Pulling Tool

SB Pulling Tool



SS Pulling Tool

## SB

Size (ins)	OD (ins)	Fish Neck
1.1/2	1.437	1.187
2	1.766	1.375
2.1/2	2.188	1.375
3	2.734	2.313

## SS

Size (ins)	OD (ins)	Fish Neck
1.1/2	1.430	1.187
2	1.770	1.375
2.1/2	2.180	1.375
3	2.840	2.313

# COMPONENT OTIS 'S PULLING TOOL

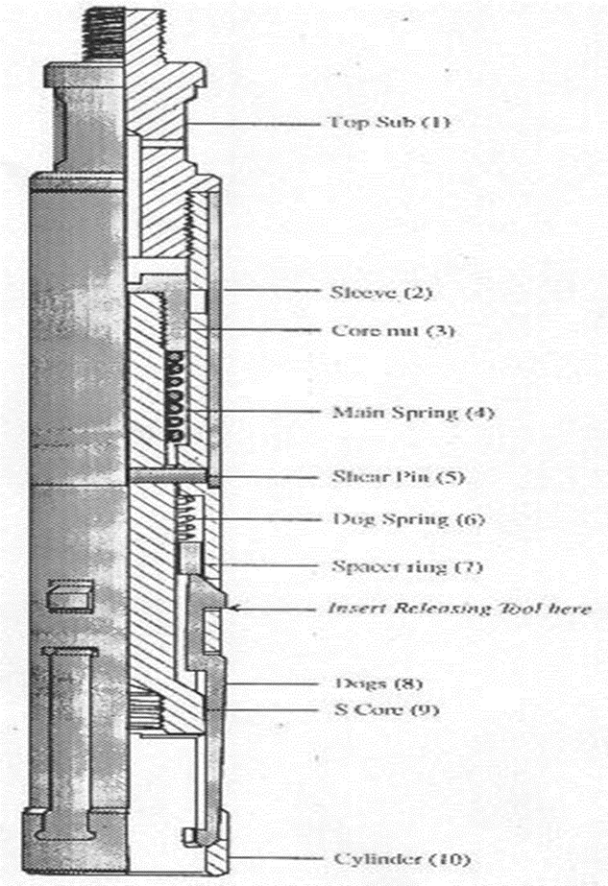

# OTIS `R Series Pulling Tool

1. To engage an external fishing neck.
2. RB (Long Core - Short Reach)
3. RS (Short Core - Long Reach)
4. Jarring up to shear pin



# OTIS 'R Series Pulling Tool



RB Pulling Tool



RS Pulling Tool

## RB

Size ( ins)	OD (ins)	Fish Neck
1.1/2	1.430	1.187
2	1.770	1.375
2.1/2	2.180	1.375
3	2.740	2.313

## RS

Size ( ins)	OD (ins)	Fish Neck
1.1/2	1.430	1.187
2	1.770	1.375
2.1/2	2.180	1.375
3	2.740	2.313

# COMPONENT OTIS 'R SERIES PULLING TOOL

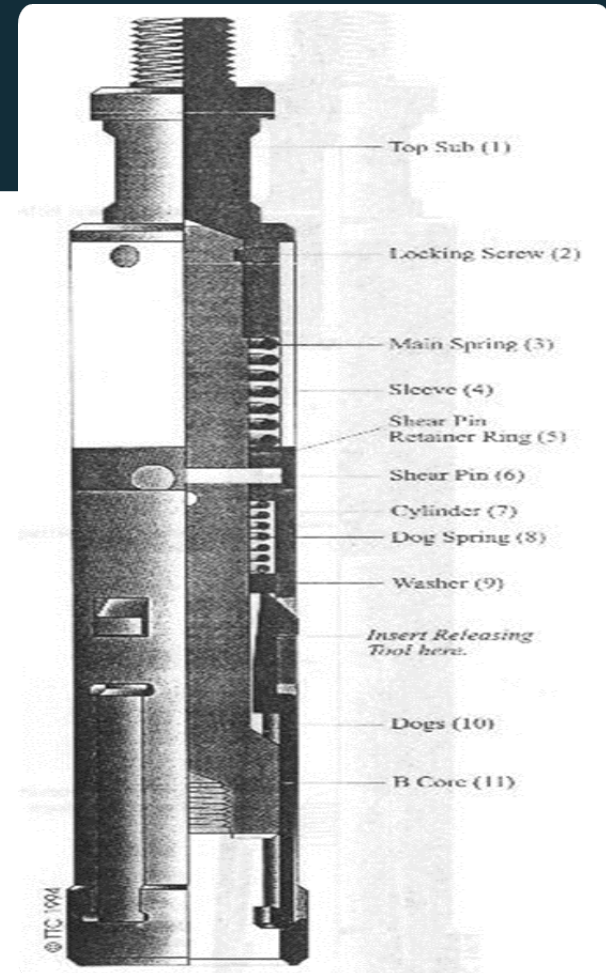

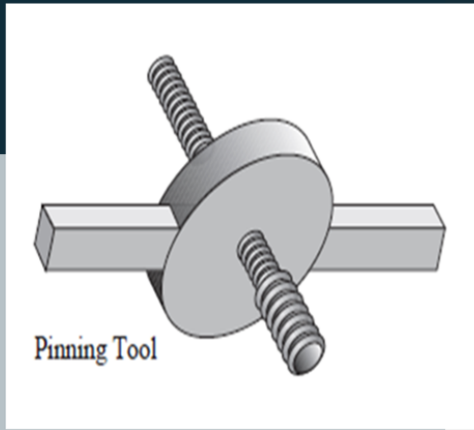

Used to re-pin the pulling tool 'R' and 'S' Series  
*\*Inserting it into the bottom of tool*

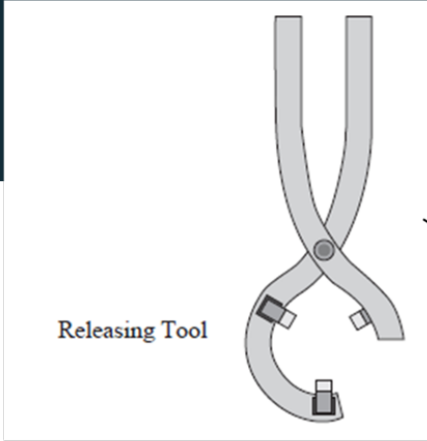

Used to release pulling tool 'R' and 'S' Series  
from the fish engaged



# Tools for 'R' and 'S' series

## OTIS GS Pulling Tool

1. Jarring down to shear pin.
2. To pull any subsurface flow control devices which have internal fishing neck.

Nominal Size (ins)	Tools O.D (ins)	Tool Fish Neck (in)
2	1.875	1.375
2.1/2	2.313	1.750
3	2.750	2.313
5	4.562	2.125



---

# COMPONENT OTIS GS PULLING TOOL

---



# OTIS GR Pulling Tool

---

- **Jarring Upward to Shear**
- **To cut things, we use a jarring motion.**
- This works best for things with a special kind of connector called an "Otis" fish neck.
- Before you try to cut, you must take out the pin from the GS tool.
- This process uses both GS and GU tools together.



# COMPONENT T OTIS GR PULLING TOOL

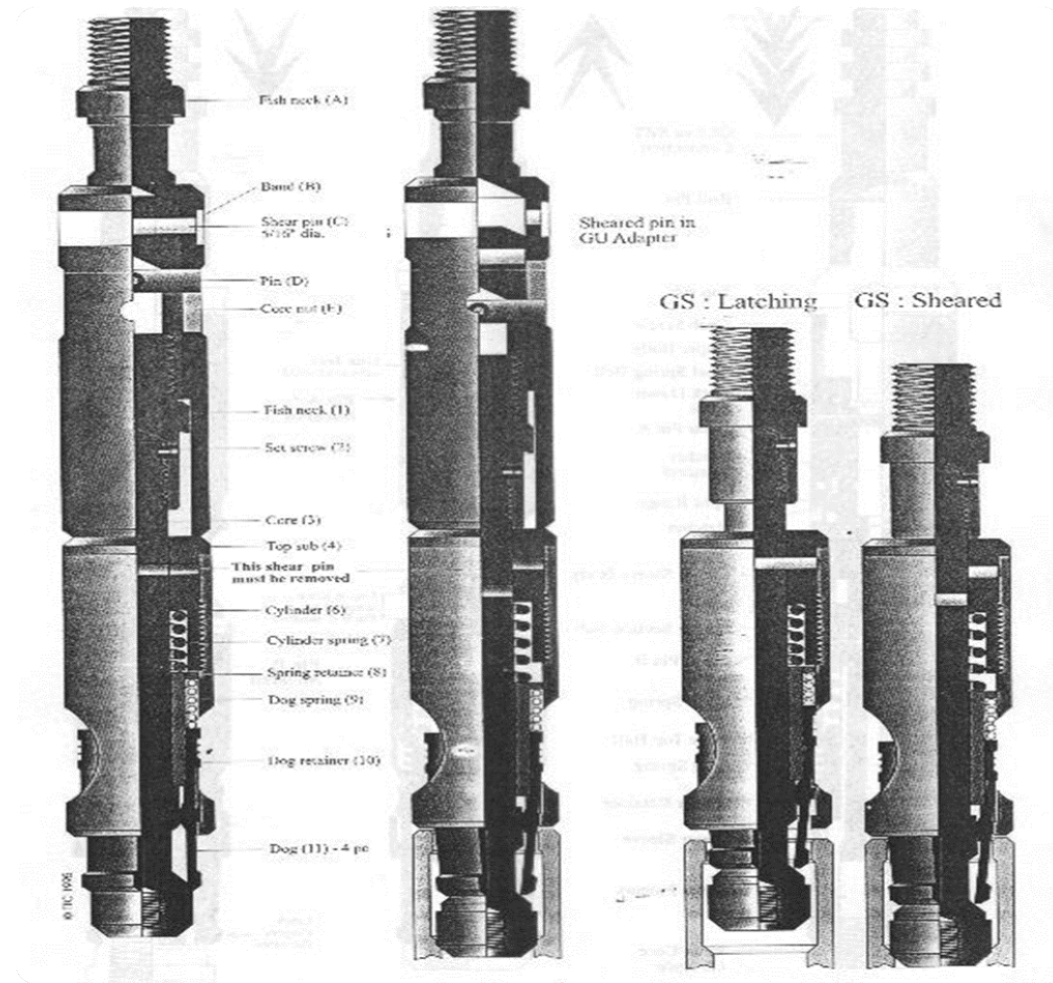

# Service Tools



# Tubing Drift

- **A tubing drift is a tool that measures the size of a well's tubing.**
- It checks if the tubing is clear.
- It makes sure tools can fit through the tubing.
- It helps find out if there are things blocking the well.

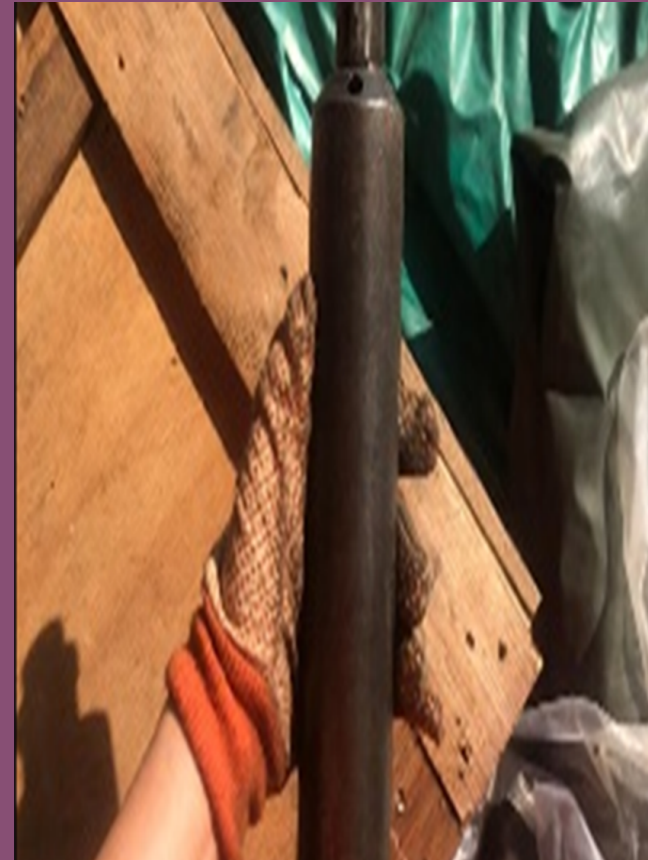

# Gauge Cutter

- A gauge cutter is a tool that measures the size of a well and removes things blocking it.
- It checks if the well is clear.
- It cuts away sand, scale, or wax.
- It's used before sending other tools down the well to make sure they can move easily.



Gauge Cutter		
O.D. (in.)	Fishneck O.D. (in.)	Bottom Connection (in.)
1.25 – 1.50	1.187	15/16
1.50 – 2.00	1.375	15/16
2.00 – 2.50	1.375	15/16
2.50 – 3.00	1.750	1.1/16

# Wire Scratcher

- **A wire scratcher is a tool like a brush that cleans things in a well.**
- It removes wax, scale, and sand.
- If it doesn't work well, we use other tools like a gauge cutter, ring, or tubing broach.

Wire Scratcher		
O.D. (in.)	Fishneck O.D. (in.)	Bottom Connection (in.)
1.000	1.375	15/16
1.500	1.375	15/16
1.875	1.750	1.1/16
2.125	1.750	1.1/16



# Lead Impression Block

- A **lead impression block** is a tool used to see what the top of a stuck object in a well looks like.
- It helps us choose the right tool to get it out.
- It's also called a "slickline bottom-hole camera."



Lead Impression Block		
O.D. (in.)	Fishneck O.D. (in.)	Bottom Connection (in.)
1.25 – 1.50	1.187	15/16
1.50 – 2.00	1.375	15/16
2.00 – 2.50	1.375	15/16
2.50 – 3.00	1.750	1.1/16

# Fluted Centralizer



- A centralizer is a tool used in wells that are not straight.
- It helps keep other tools in the center of the well.

Fluted Centralizer		
O.D. (in.)	Fishneck O.D. (in.)	Bottom Connection
1.50 – 2.50	1.375	15/16
2.50 – 3.50	1.750	1.1/16
3.50 – 4.50	2.313	1.9/16



# Blind Box

- A blind box is a tool used to push things down a well with a lot of force.
- It can break the wire if you can't get the tools out.
- The bottom is hard to prevent damage.

# Tubing Swage



1  
2  
3.

- The tubing swage is a specialized tool designed to address specific issues in wellbore operations.
- Key functions and applications of a tubing swage:
  - Restoring minor tubing collapses
  - Removing large obstructions
  - Operation with a hydraulic or spring jar

Tubing Swage		
O.D. (in.)	Fishneck O.D. (in.)	Top Connection (in.)
1.25 – 1.50	1.187	15/16
1.51 – 2.50	1.375	15/16
2.51 – 3.00	1.750	1.1/16
3.01 – 5.00	2.313	1.1/16

# Tubing Broach



Diamond Cut broach



Straight Cut broach

- A **Tubing broach tool** is used to clean the inside of a well.
- It removes rough edges, buildup, scale, and rust.
- There are two types: diamond cut and straight cut.

Tubing Broach		
O.D. (in.)	Fishneck O.D. (in.)	Top Connection
1.50 – 2.50	1.375	15/16
2.51 – 4.00	1.750	1.1/16
4.01 – 5.00	2.313	1.1/16
5.01 – 6.00	3.125	1.9/16

# Pressure Control Equipment (PCE)

- Stuffing Box
- Lubricator
- Quick Test Sub
- Blowout Preventer
- Ball Valve
- Wellhead Crossover
- Control Panel
- Single Well Control Panel

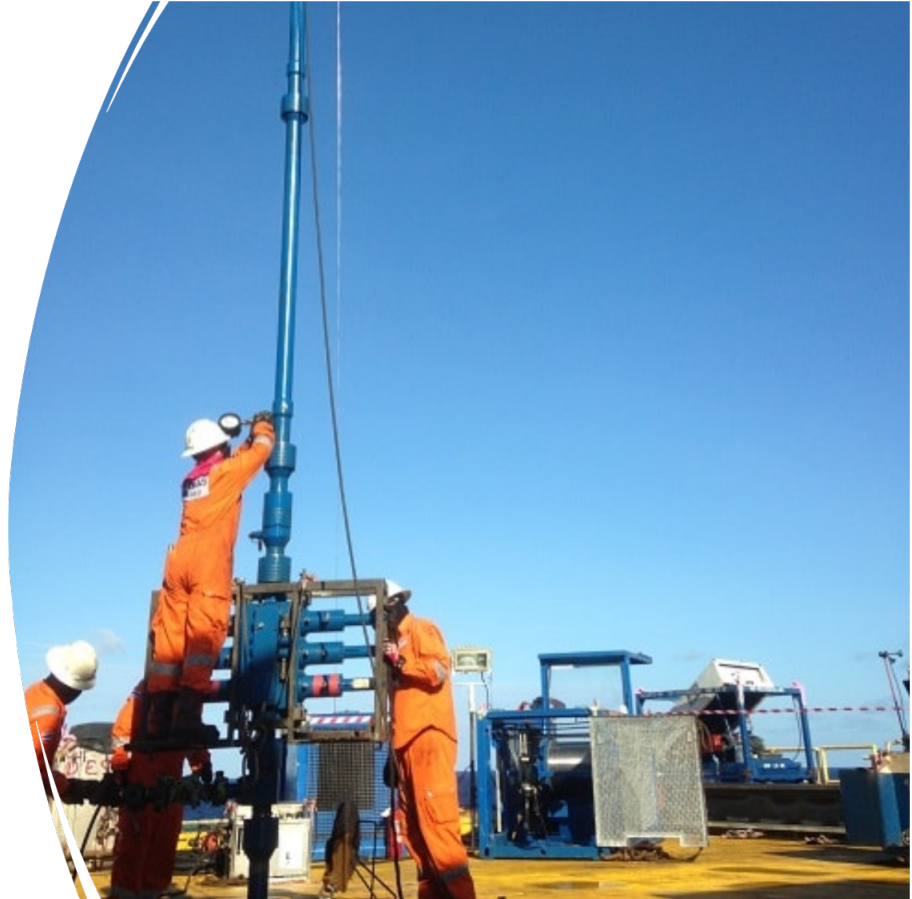

# Quick Union

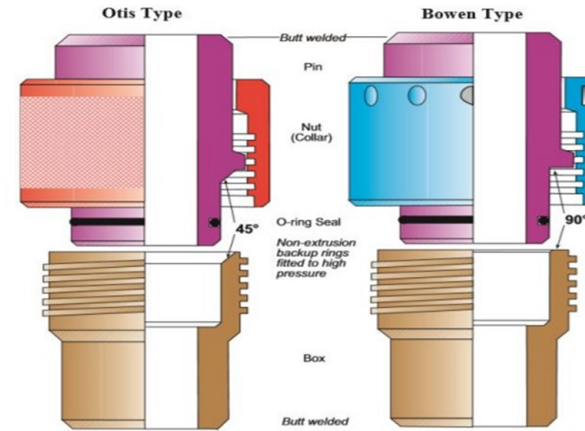
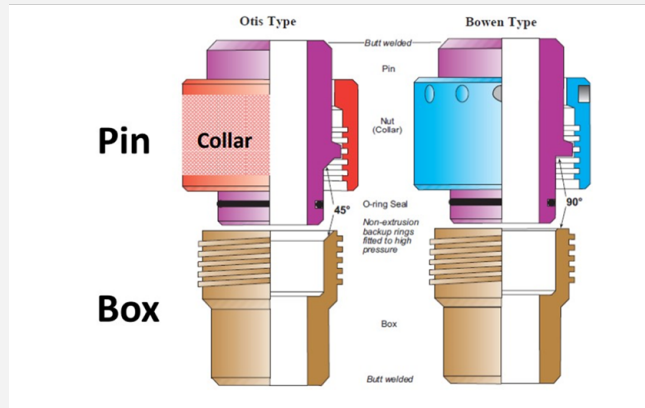

# Component/Parts

- **Connection Types**
- **Otis type:** Connects at a 45-degree angle.
- **Bowen type:** Connects at a 90-degree angle.

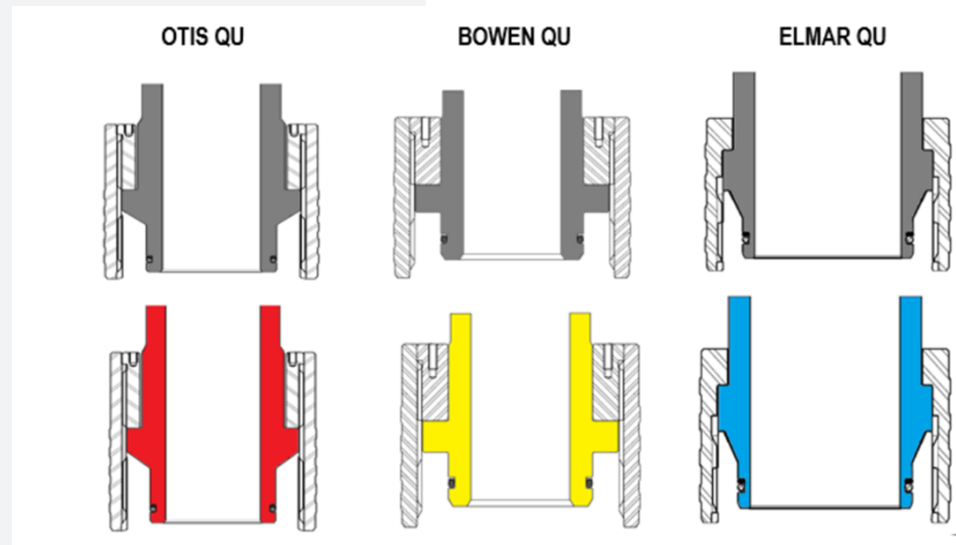

# Stuffing Box

- **Sealing Device and Wire to Sheave Ratio**
- **Sealing Device:**
  - Attached to the top of lubricator sections.
  - The main barrier in operations.
- **Stuffing Box:**
  - Another name for the sealing device.
- **Wire to Sheave Ratio:**
  - 1:120 (one wire for every 120 sheave turns).
- **Hydraulically Controlled Packing Nuts:**
  - Available for use.
  - Can be operated with a hand pump.



# Component/Parts

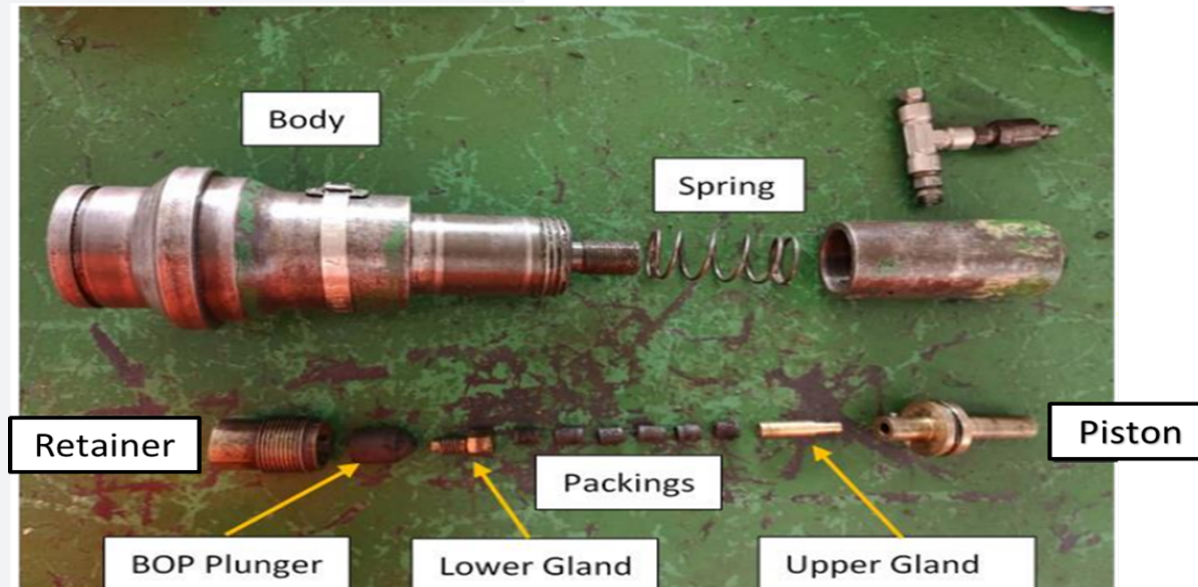



# Lubricator

- A lubricator is a tool that lets you put tools in and take them out of a well while there's pressure.
- **Types:**
  - **Ported Lubricator:** Has a valve to release pressure.
  - **Non-Ported Lubricator:** Doesn't have a valve to release pressure.
- **Lengths:**
  - **Main lubricator:** 8 feet long.
  - **Pup joints:** 2, 3, or 4 feet long.

# Quick Test Sub

- **This tool is used to test pressure control equipment.**
- It has two O-rings to seal things tightly.
- You can use hydraulic pressure to check if the equipment can still hold pressure.



# Ball Valve

- **This tool can hold pressure from both top and bottom.**
- **Operation:** You can use hydraulics or a handle to control it.
- **Safety:** It's extra safe for closing the well. It's placed between the wireline valve and the BOP.

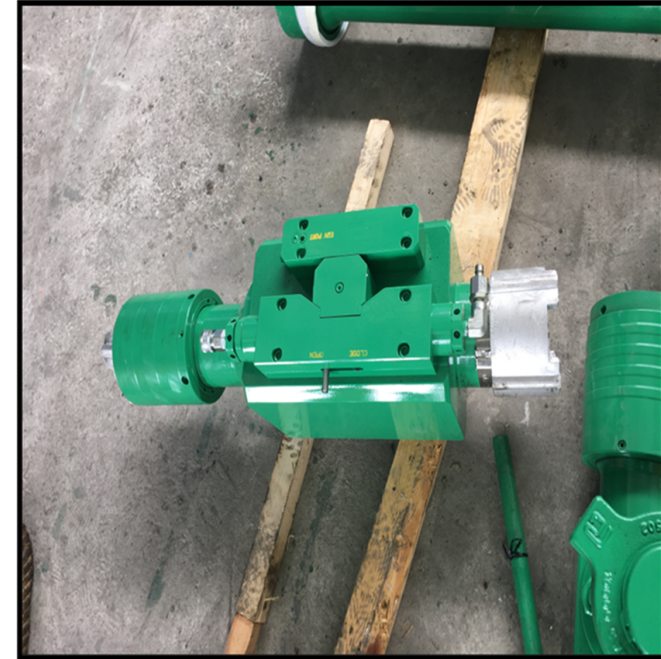

# Wellhead Crossover

- **A Wellhead Crossover connects to the wellhead.**
- **Purpose:** It lets you measure and control pressure in the well.
- **Seals:** It makes sure the well is sealed all the way down.
- **Sizes:** There are different sizes for different wellheads.



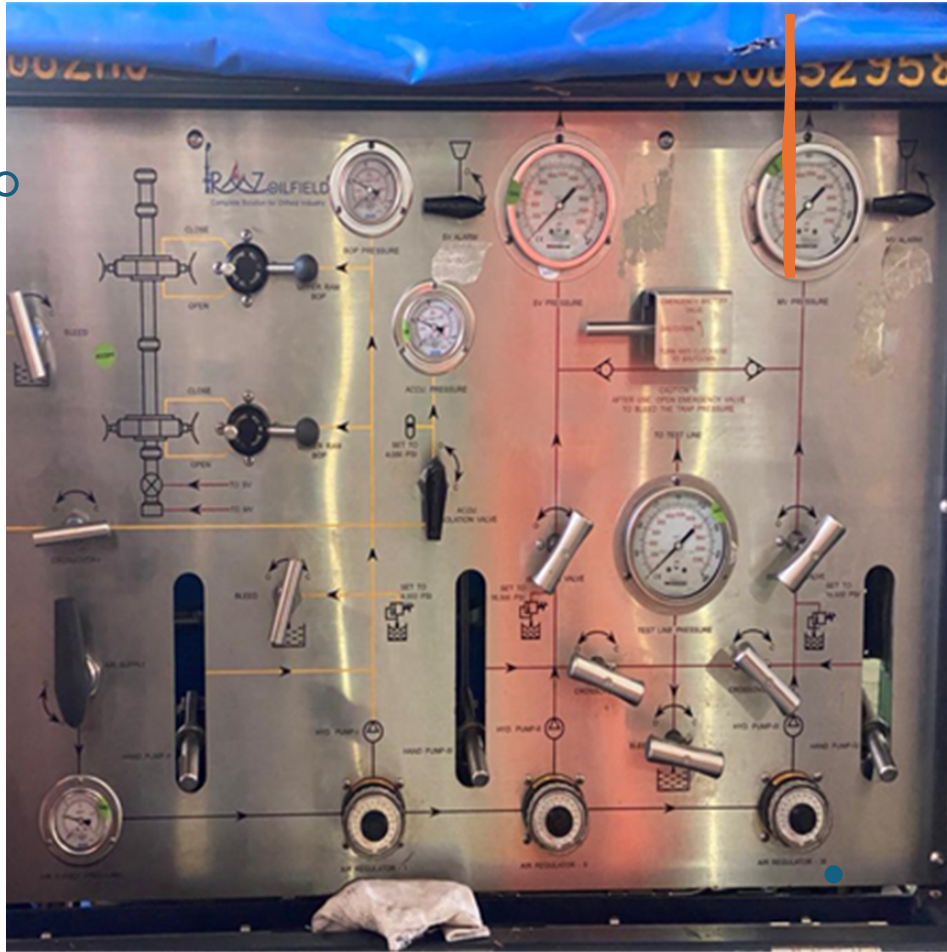

# Control Panel

- **This unit controls many parts of a wellhead.**
- **Controls:** It operates the BOP, stuffing box, safety valve, master valve, and test line.
- **Emergency:** It has a way to shut down the well quickly in case of an emergency.
- **Tests:** It can test the equipment at different pressures (2000 to 3000 psi).

# Single Well Control Panel

- **An SWCP provides power and control for Christmas tree valves.**
- **Operates:** It works with SSV (2800 psi) and TRSCSSV (3800 psi) valves.
- **Equipment:** It has 2 Haskel pumps.
- **Max Pressure:** It can handle up to 10,000 psi.
- **Tests:** It can test equipment at 5,500 to 6,500 psi.



# PCE Accessories

○



*Enerpac Hand Pump*



*Hunting Lifting Clamp*



*Hunting Lifting Cap*

## ○ Surface Equipment

---

- Wireline Mast
- Air Compressor
- Power Pack
- Reel Skid Unit
- Generator Set (GenSet)



# Oil and Gas Hazardous

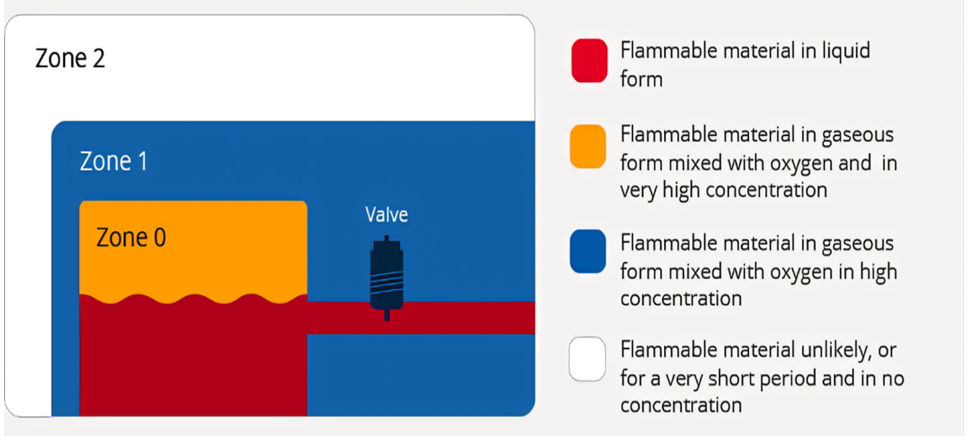

# Oil and Gas Hazardous Zone

---

## Wireline Mast

---

- **This tool lifts and holds the lubricator in place during wireline operations.**
- **Zone:** It's used in Zone 1.



# Wireline Mast Control

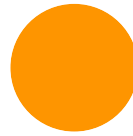

1. Inlet pressure gauge
2. Erector
3. Extender
4. Block (green)
5. Block (red)

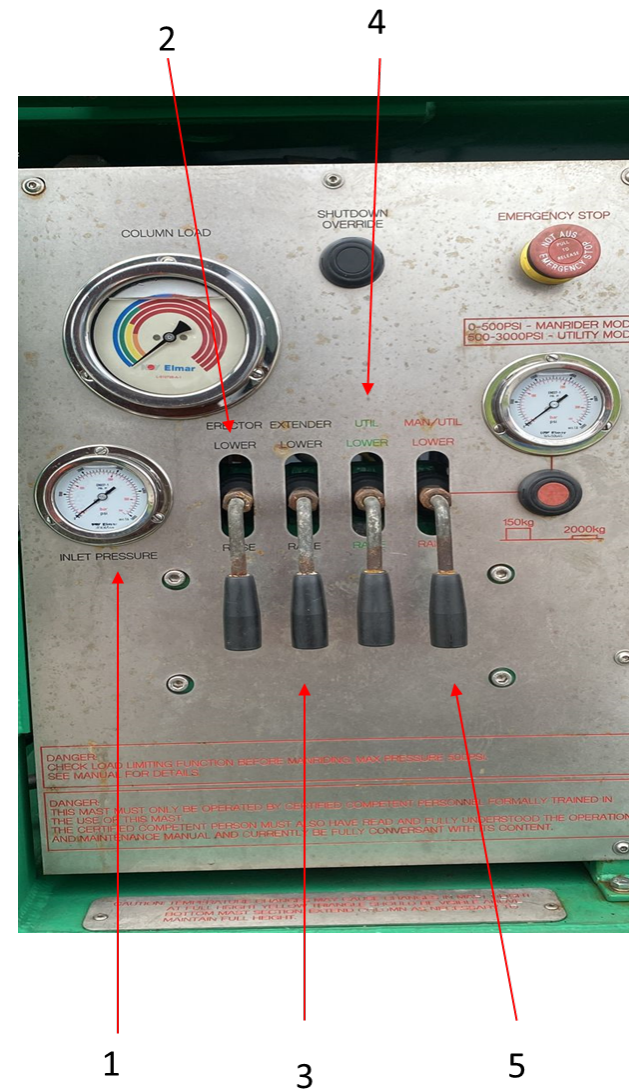

# Air Compressor

Function: Supplies air.

• **Safety:** It's rated for Zone 2 areas (areas with low levels of flammable gas)

• **Start:** It can be started using a spring or hydraulic system.

Equipped with both spring and hydraulic starters.





# Power Pack

- **Diesel-Driven Power Pack**
- **This machine is powered by diesel.**
- **Safety:** It's rated for Zone 2 areas.
- **Starters:** It can be started using a spring, hydraulic, or air system.
- **Power:** It provides hydraulic power to the reel skid unit and wireline mast.
- **Pressure:** It supplies hydraulic power to the reel skid unit at 2500 psi.
- **Permit:** You need a permit to do hot work (like welding or cutting) near it.

# Power Pack Daily Checklist

- Hydraulic oil
- Engine oil
- Radiator
- Coolant
- Oil filter
- Connection hose



1. Rotate the sentinel valve clockwise.



2. turn the winding nut till the spring tension sight glass turn to green.

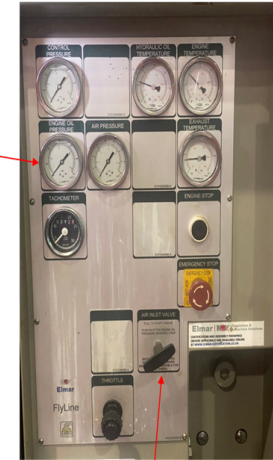

4. Engine oil pressure at 40-60psi

3. Pull the air inlet valve up.

## Reel Skid Unit

---

- **A RSU is a machine that moves tools up and down in a well.**
- **Direction:** A lever chooses which way the drum turns.
- **Brake:** A brake stops the drum or is used for jarring.
- **Speed:** A hydraulic valve controls how fast the drum turns.
- **Depth:** An odometer shows how deep the wire is.
- **Weight:** A weight indicator measures how much tension is on the wire.

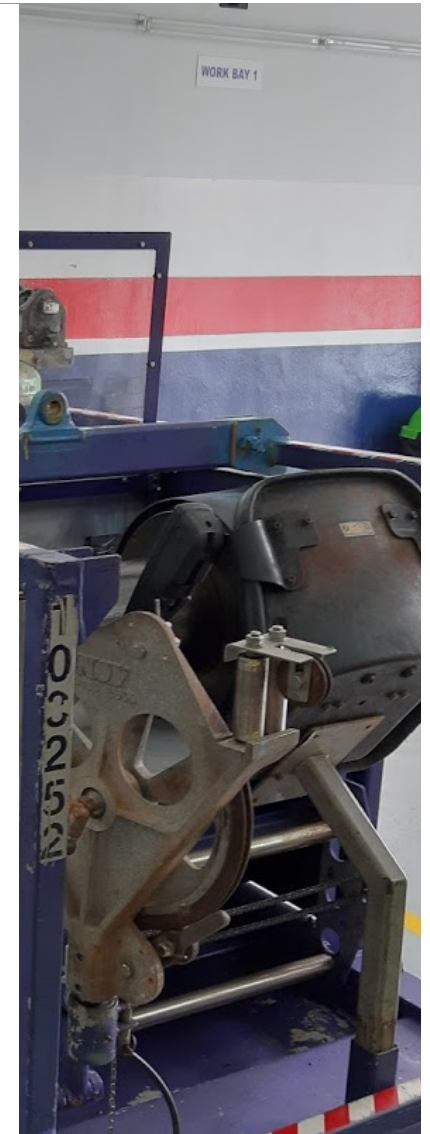

# Generator Set (GENSET)

- A GenSet turns mechanical energy into electrical energy.
- **Power Source:** It's powered by a diesel engine.
- **Safety:** It's rated for Zone 2 areas.
- **Safety System:** It has a safety system to shut down if:
  - It spins too fast (1700 RPM)
  - The engine oil pressure is too low (15 psi)
  - The coolant gets too hot (90 degrees Celsius)
  - The exhaust gets too hot (200 degrees Celsius)



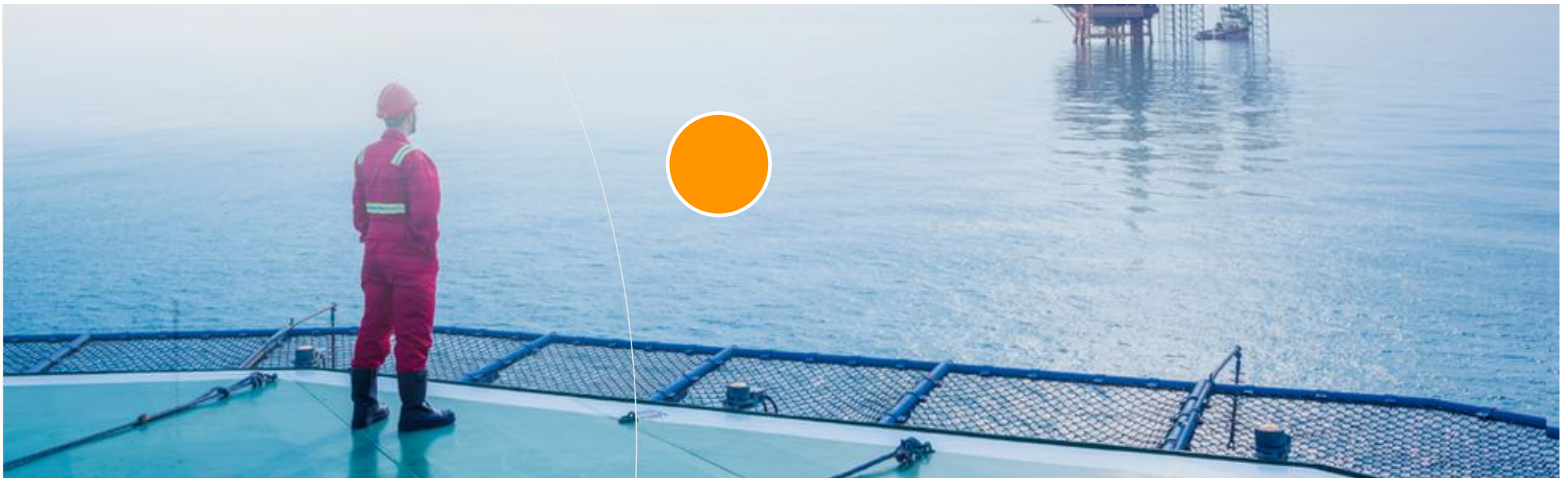

## Conclusion

- **Understand the equipment and tools:** Learn what each piece does and how to use it.
- **Learn to set up the rig:** Know the basic steps to get the rig ready.
- **Learn about slickline operations:** Understand the process of using slickline tools.
- **Learn about maintenance:** Know how to do regular maintenance to keep things working well.

# Job Summary

- **Perform bailing (CHESS)**
- **Perform monitor WHCP (CHESS)**
- **Perform Tcc and Logging (HESS)**
- **Perform tcc and KX valve (CHESS)**
- **Perform TCC and SGS (VESTIGO)**
- **Perform Perforation and GLVCO (VESTIGO)**
- **Perform fishing job (VESTIGO)**
- **Perform PXX PLUG , Insert Valve and GLVCO (VESTIGO)**





Q&A