

SLICKLINE ASSISTANT WORKBOOK

IMPORTANT NOTE:

1. Your point of reference to complete this workbook may be obtained from the following
 - Training Manual and any other training materials provided together with this workbook
 - Your Trainer, Assessor (Slickline Operator), Verifier (FSM) or senior colleagues
 - SOP / Quality Procedures & Processors
2. The completion of this Workbook is a joint effort and responsibility between you and your assessor therefore you have the obligation to request from your assessor to be assessed upon your completion of each topic
3. The completion of this Workbook is part of the MANDATORY requirements which you must fulfill to qualify for a promotion
4. Your training program is mostly self-driven, including this Workbook. It requires individual initiatives, dedication and commitment to complete the process.

| | |
|----------------|--------------------------------|
| NAME | MUHAMMAD ARMIN RIFQI BIN ANUAR |
| DATE OF JOIN | 15/7/2023 |
| CONTACT NO. | 013-8048186 |
| RECEIVED DATE | |
| DATE COMPLETED | 19/10/24 |

B. SURFACE EQUIPMENT

B.1. STUFFING BOX

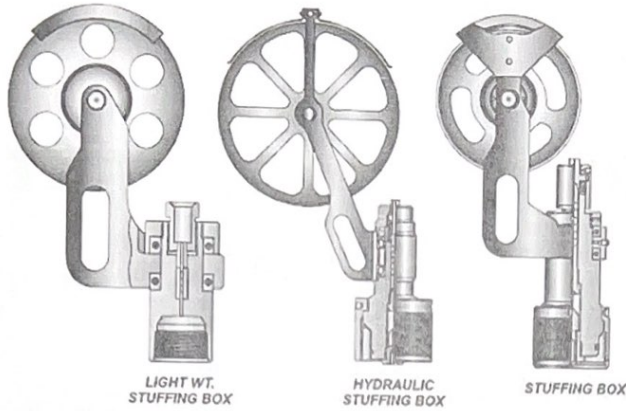

What is Stuffing Box

A Stuffing Box is a key component in slickline/wireline operations that helps maintain a seal around the wireline as it enters the wellbore under pressure. It prevents well fluids or gases from escaping while allowing the wireline to move in and out of the well.

What is the purpose of stuffing Box

Allows the wireline to enter the well under pressure and provide a seal should be wireline break and be blow out of packing. Is a primary pressure barrier.

How to operate Stuffing Box

Positioned at the uppermost point of the PCE string

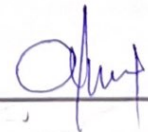
 3/10/24



What is maintenance required for Stuffing Box

| Components | Description |
|--------------------------------|---|
| Packings | Not worn out. If the packing nut is near the lower end of its movement, there may not be sufficient movement remaining to increase the packing compression force to maintain a seal during wireline operations. |
| Sheave | The correct size for the line in use (16" for 0.125", or 20" for 0.140"). |
| Upper and lower packing glands | Check for wear. If they are worn oversize they should be replaced, as worn glands allow the wire to cut the packings faster. |
| BOP Plunger | Check for wear and freedom of vertical movement. |
| Sheave Bearings | Check for free spinning and replace the bearings if necessary. |
| Sheave Staff | Check for freedom of swivel movement. It is essential that the sheave follow the wire direction during rig-up or the wire can jump out of the groove and become damaged. |
| Sheave Guard | Tight and adjusted close to the sheave to ensure it will trap the line in the event of a line break. |

What is safety precaution required for Stuffing Box

- Check for Leaks: Regularly inspect the Stuffing Box for any signs of leaks or wear to ensure it's maintaining a proper seal.
- Use Proper PPE: Wear appropriate personal protective equipment (PPE) such as gloves, safety glasses, and protective clothing to safeguard against any potential exposure to well fluids.
- Depressurize Before Working: Ensure that the well is depressurized and that all pressure is safely released before working on or around the Stuffing Box.
- Follow Operating Procedures: Adhere to standard operating procedures and guidelines for installing, maintaining, and operating the Stuffing Box.
- Avoid Over-tightening: Be careful not to over-tighten the packing in the Stuffing Box, as this can damage the packing material and lead to leaks.
- Monitor Pressure Gauges: Keep an eye on pressure gauges to ensure that the pressure remains within safe operating limits.
- Ensure Proper Installation: Make sure the Stuffing Box is correctly installed and aligned to avoid any operational issues or equipment damage.



- **Inspect Packing Regularly:** Regularly inspect and replace the packing material as needed to maintain an effective seal and prevent leaks.
- **Clear Work Area:** Keep the work area around the Stuffing Box clear of any unnecessary personnel or obstacles to prevent accidents.

What is potential hazard during handling Stuffing Box

- **Pressure Exposure:** Accidental exposure to high-pressure well fluids or gases if the Stuffing Box is not properly sealed or if pressure is not safely released.
- **Leakage:** Leaks from a damaged or improperly maintained Stuffing Box can lead to exposure to hazardous well fluids or create a dangerous work environment.
- **Heavy Equipment:** The Stuffing Box and associated equipment can be heavy, posing risks of injury from lifting or moving it improperly.
- **Pinch Points:** The Stuffing Box assembly can have moving parts that may pinch or trap fingers or limbs.
- **Chemical Exposure:** Exposure to chemicals or fluids from the well if there are leaks or spills during handling.
- **Equipment Failure:** Malfunction or failure of the Stuffing Box can lead to uncontrolled release of pressure or fluids, creating a hazardous situation.
- **Slips, Trips, and Falls:** Working around the Stuffing Box may involve wet or slippery surfaces, increasing the risk of slips, trips, and falls.

3/10/24



Draw & name each part of stuffing box

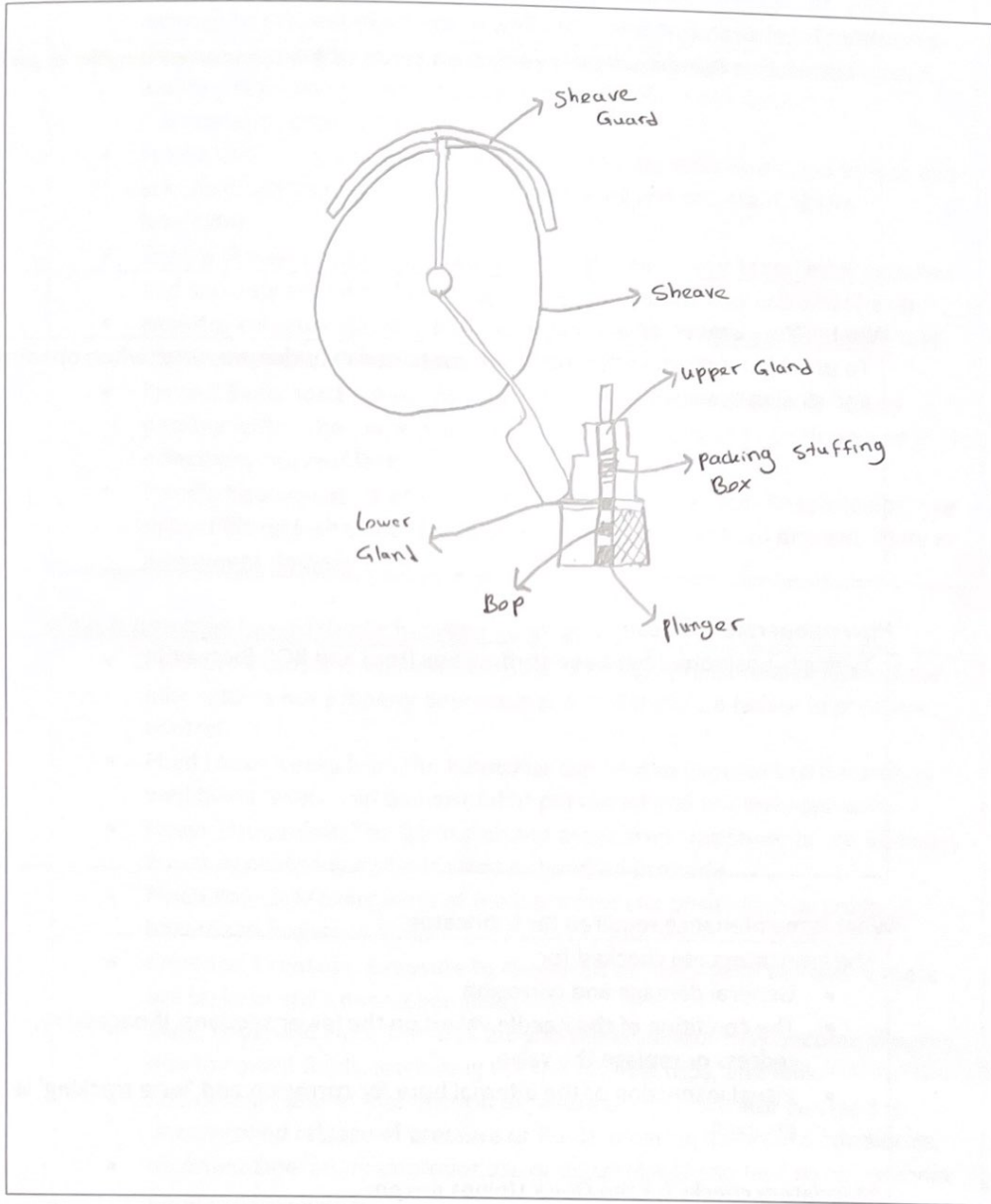

3/10/29



B.2. LUBRICATOR

What is Lubricator

Lubricators (also known as risers) are a series of interconnected lengths of pipe.

What is the purpose of Lubricator

To provide a space for the tool to be contained in under pressure, when opening and closing the wellhead.

How to operate Lubricator

Typically positioned between stuffing box (top) and BOP (bottom).

What is maintenance required for Lubricator

The lubricators are checked for:

- General damage and corrosion
- The condition of the needle valves on the lower sections. If necessary, redress or replace the valve
- Visual inspection of the internal bore for corrosion and 'wire tracking' wear grooves

Mandatory checks for the Quick Unions are on:

- The condition of the O-ring groove
- The condition of the pin and box sealing surface
- The pin and box size

3/10/24



What is safety precaution required for Lubricator

- **Check for Leaks:** Inspect the lubricator regularly for any signs of leaks or damage to prevent exposure to well fluids and ensure proper functioning.
- **Depressurize Before Working:** Ensure that the lubricator is depressurized, and any residual pressure is safely released before performing maintenance or adjustments.
- **Follow Operating Procedures:** Adhere to the manufacturer's guidelines and standard operating procedures for operating and maintaining the lubricator.
- **Ensure Proper Installation:** Confirm that the lubricator is correctly installed and securely connected to avoid operational issues and potential hazards.
- **Monitor Pressure Gauges:** Keep an eye on pressure gauges to ensure that the lubricator is operating within safe pressure limits.
- **Inspect Seals and Packing:** Regularly check and maintain the seals and packing within the lubricator to ensure they are in good condition and effectively prevent leaks.
- **Handle Equipment Carefully:** When moving or adjusting the lubricator, use proper lifting techniques and avoid abrupt movements to prevent injury or equipment damage.

What is potential hazard during handling Lubricator

- **Pressure Exposure:** Accidental exposure to high-pressure well fluids if the lubricator is not properly depressurized or if there's a failure in pressure control.
- **Fluid Leaks:** Leaks from the lubricator can lead to exposure to hazardous well fluids, which can be harmful to personnel and the environment.
- **Heavy Equipment:** The lubricator and associated components can be heavy and may cause injury if not lifted or handled properly.
- **Pinch Points:** Moving parts of the lubricator can pose pinch or crush hazards to fingers or limbs.
- **Chemical Exposure:** Exposure to chemicals or fluids from the well if there are leaks or spills during handling.
- **Slips, Trips, and Falls:** The area around the lubricator may become slippery due to spilled fluids, increasing the risk of slips, trips, and falls.
- **Equipment Failure:** Malfunction or failure of the lubricator can lead to uncontrolled release of pressure or fluids, creating hazardous conditions.
- **Incorrect Operation:** Improper use or adjustments can lead to operational failures or accidents.

3/10/24



Draw & name each part of Lubricator

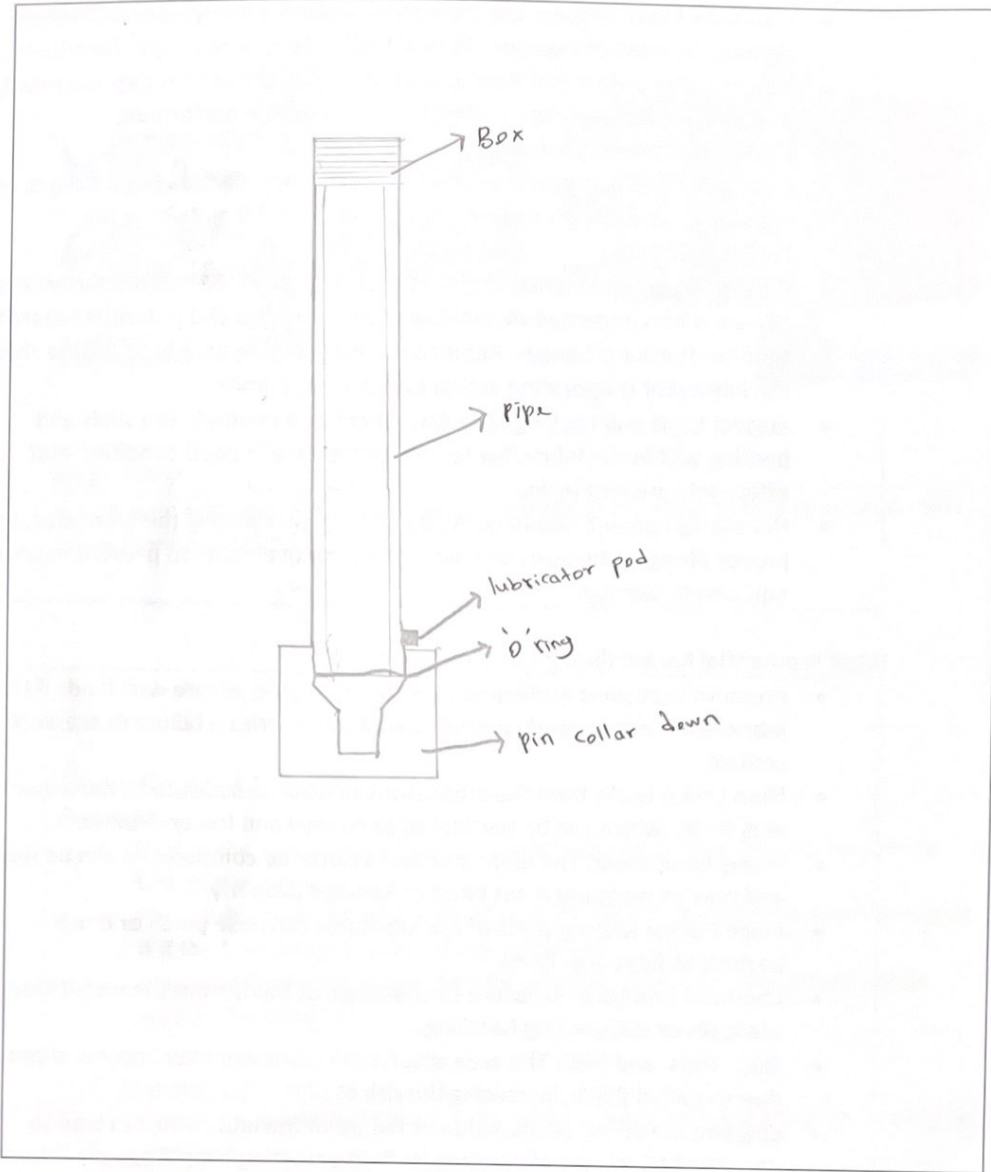

3/10/24



B.3. BLOWOUT PREVENTER (BOP)

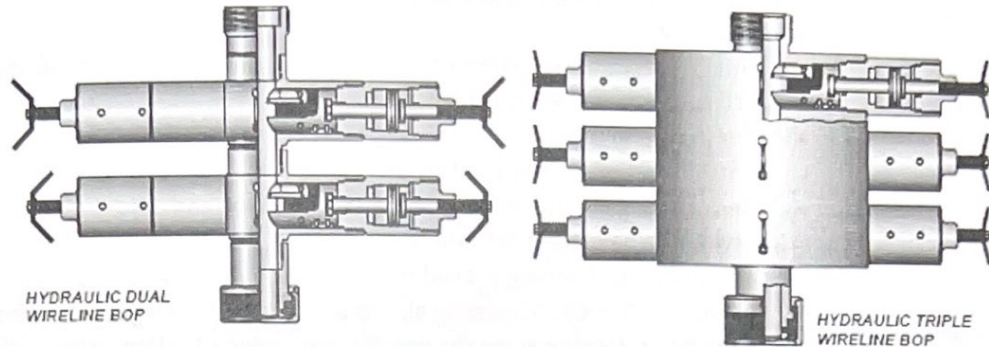

What is BOP

A BOP (also known as a wireline valve) is installed between the tree connection and lower lubricator section.

What is the purpose of BOP

Purposes:

- Enable the well pressure to be isolated without cutting the wire by closing the master valve
- Permit the assembly of the wireline cutter above the BOP rams and dropping it if the toolstring becomes stuck in the well
- Allow slickline work under the well pressure on surface equipment, while wire in the wellbore

How to operate BOP

- Check the Equipment: Inspect the BOP for any issues and ensure it's ready to use.
- Connect Hydraulic Lines: Make sure all hydraulic lines are properly connected.
- Monitor Pressure: Keep an eye on pressure gauges to ensure safe levels.
- Activate Controls: Use the control panel to engage the BOP's rams or blades as needed.
- Seal the Well: Close the rams to seal the well if needed.
- Handle Emergencies: Know how to use the shear rams to cut the pipe and seal the well in an emergency.
- Depressurize and Maintain: Release any pressure when done and inspect for damage.

Clut. 3/10/24



What is maintenance required for BOP

Level 1 Service - To be carried out after every job

- Wash down
- Initial inspection – remove rams and cylinders, inspect all seals and sealing surfaces, remove valves and inspect
- Grease up and rebuild
- Function and pressure test at working pressure
- Check lifting gear and record last certification type and date

Level 2 Service - To be carried out once a year

- Carry out Level 1 service procedure
- Replace all 'O' rings. Inspecting all components and sealing surfaces for corrosion or damage along the way Pay particular attention to the surfaces below the rams
- Rebuild Wireline Valve and pressure test to Test Pressure.
- Function test at Working Pressure

Level 3 Service - To be carried out every 5 years

- Carry out Levels 1 and 2 service procedure
- Strip Wireline Valve to component parts discarding all 'O' rings/back-up rings
- MPI (Magnetic Particle Inspection) of all parts.
- Rebuild using seal kit and any necessary new parts.
- Rebuild Wireline Valve and pressure test to Test Pressure
- Function test at Working Pressure
- Third party certificate of final test and inspection, certificate of conformity and lifting certification

What is safety precaution required for BOP

- Inspect all inner/outer ram seals, O-ring and seals. Replace when showing tear, cut,
- loss of bond between metal plates and rubber.
- Install thread protector before storing.
- Annually or after 10 jobs (whichever comes first), replace all seals in equalizing valve assembly.
- Annually or after 10 jobs (whichever comes first), inspect hydraulic cylinder assembly and replace all seals.

What is potential hazard during handling BOP

- Physical injury
- Falls
- Hydraulic fluid exposure
- Pressure-related accidents
- Noise exposure
- Toxic gas exposure

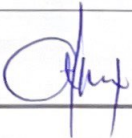
 3/10/24



Draw & name each part of BOP

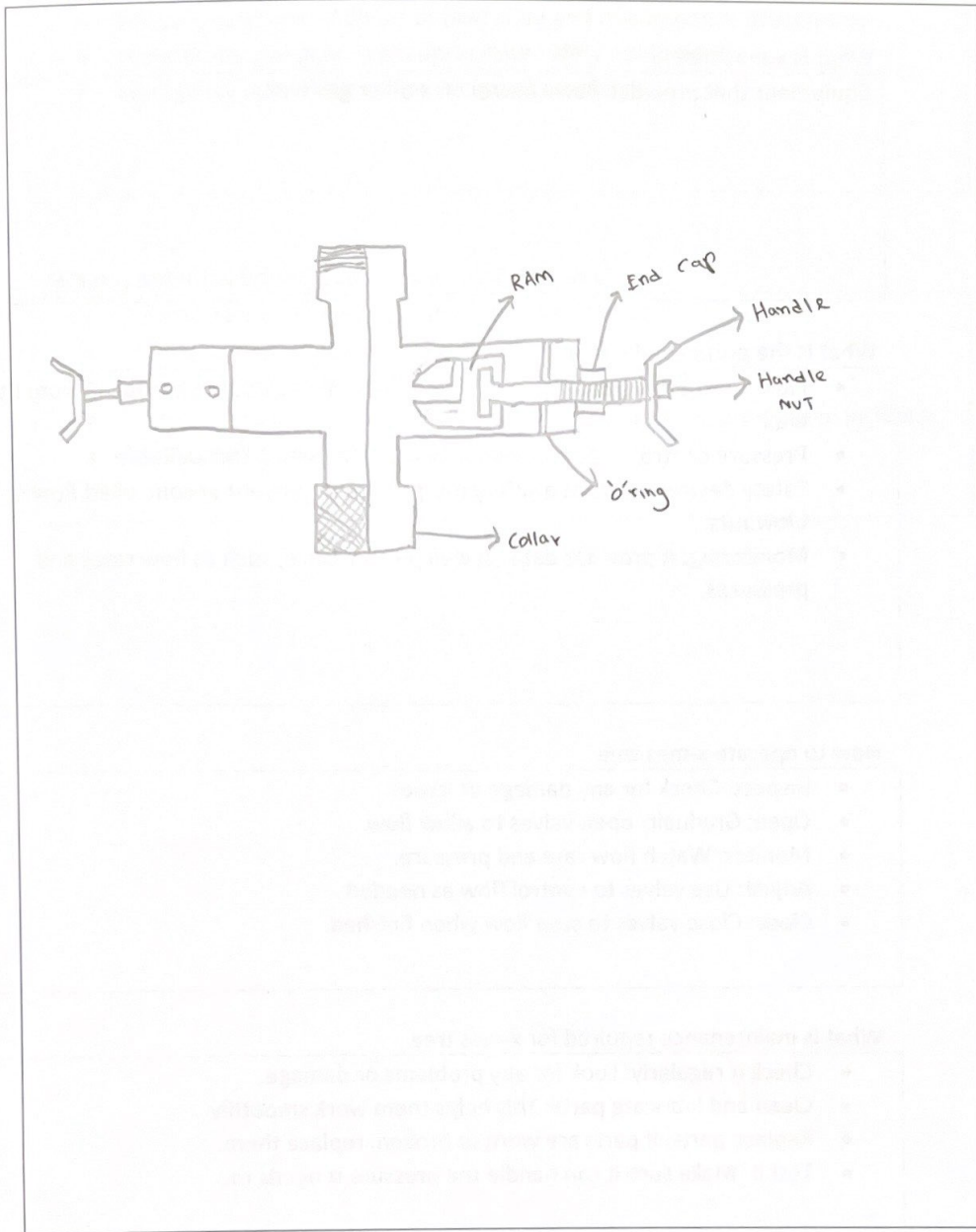

3/10/29



B.4. X-MAS TREE

What is x-mas tree

Equipment that provides flow control on a oil or gas well.

What is the purpose of x-mas tree

- Flow control: It regulates the rate at which oil and gas are produced from the well.
- Pressure control: It maintains a safe pressure within the wellbore.
- Safety device: It acts as a safety mechanism to prevent uncontrolled flow or blowouts.
- Monitoring: It provides data on well performance, such as flow rates and pressures.

How to operate x-mas tree

- Inspect: Check for any damage or issues.
- Open: Gradually open valves to allow flow.
- Monitor: Watch flow rate and pressure.
- Adjust: Use valves to control flow as needed.
- Close: Close valves to stop flow when finished.

What is maintenance required for x-mas tree

- Check it regularly: Look for any problems or damage.
- Clean and lubricate parts: This helps them work smoothly.
- Replace parts: If parts are worn or broken, replace them.
- Test it: Make sure it can handle the pressure it needs to.

Ally 3/10/24



What is safety precaution required for x-mas tree

- Inspect regularly: Check for damage or leaks.
- Follow procedures: Adhere to operating and maintenance procedures.
- Wear protective gear: Use appropriate safety equipment.
- Emergency plan: Have a plan in case of problems.

What is potential hazard during handling x-mas tree

- Injuries: Heavy equipment can cause physical harm.
- Falls: Working at height poses a risk.
- Fluid exposure: Exposure to oil or gas can be harmful.
- Pressure accidents: Incorrect handling can lead to pressure-related incidents.
- Noise: Loud equipment can damage hearing.

3/10/24



Draw & name each part of x-mas tree

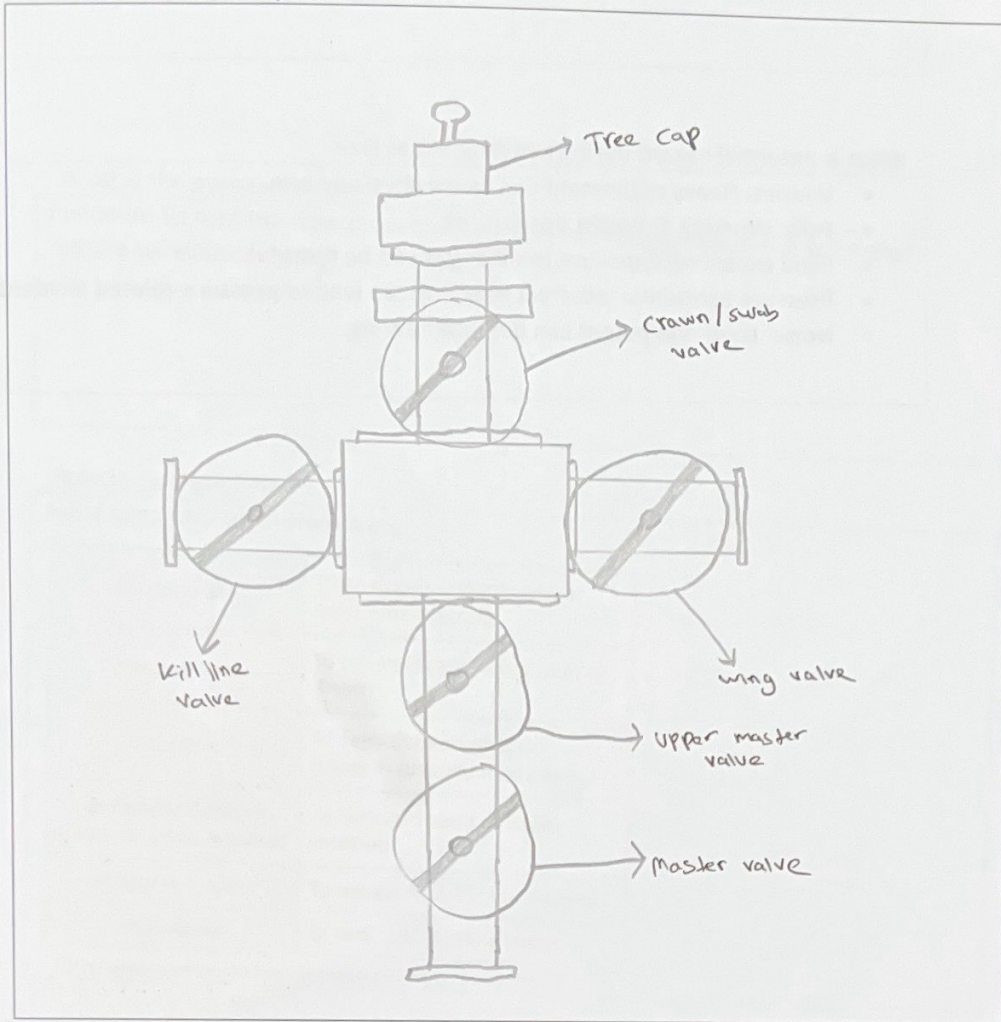

3/10/24
[Signature]



B.5. WIRELINE REEL SKID UNIT (RSU) / WINCH – SINGLE DRUM AND DOUBLE DRUM

What is RSU

A reel skid unit is a specialized piece of equipment used to transport and deploy slickline.

What is the purpose of RSU

Function: To turn the wire drum to lower and rise tool strings in the wells that require wireline servicing.

How to operate RSU

Basic controls / instruments are:

| | |
|---|---|
| Drum Brake | To keep drum stationary or used when jarring |
| Direction lever | To select rotation direction of drum |
| Gear Box | To select speed of drum rotation (usually four gears) |
| Hydraulic Control Valve (double A valve) | To control speed of drum rotation |
| Weight Indicator | To measure strain on wireline |
| Odometer | To indicate wireline depth |

*This typical control panel can be found on SOP/TIS RSU/NOV Lightline.

What is maintenance required for RSU

3/10/24



| ITEM | DESCRIPTION | MONTHS/INTERVAL | | | |
|------|--|-----------------|----|--|-----------|
| 1 | Replace measuring & pressure wheel | 500 hrs | 17 | Inspect Accumulator | 3 Monthly |
| 2 | Replace Hydraulic filter | 500 hrs | 18 | Replace hydraulic pressure filter | 3 Monthly |
| 3 | Replace hydraulic oil | 2000 hrs | 19 | Calibrate line wise & over pull system | 6 Monthly |
| 4 | Replace gear box oil | 2000 hrs/yearly | 20 | Inspect hydraulic motor coupling | 6 Monthly |
| 5 | Inspect First Aid Kit | Monthly | 21 | Calibrate mechanical depth counter | 6 Monthly |
| 6 | Inspect Fire Extinguisher | Monthly | 22 | Calibrate mechanical weight indicator | 6 Monthly |
| 7 | Walk around to check leakage or damage | Monthly | 23 | Complete performance test and fill form | 6 Monthly |
| 8 | Clean brake band & inspect brake performance | Monthly | 24 | Replace angle drive | Yearly |
| 9 | Adjust & lubricate drum drive chain | Monthly | 25 | Replace seals of quick coupling | 3 Years |
| 10 | Adjust and Lubricate drum drive chain idler | Monthly | 26 | Replace seals gear box | 3 Years |
| 11 | Inspect measuring device rollers & replace if required | Monthly | 27 | Replace seals of motor shaft | 3 Years |
| 12 | Lubricate Drum bearings & Transmission bearings | Monthly | 28 | Replace seals of relief valve & remote | 5 Years |
| 13 | Lubricate and adjust brake linkage | Monthly | 29 | Rebuild hydraulic motor | 5 Years |
| 14 | Inspect control panel and gauge | Monthly | 30 | Replace drum bearings | 5 Years |
| 15 | Inspect certificates validity | Monthly | 31 | Replace seals of directional control valve | 5 Years |
| 16 | Inspect drum RPM & compare design data | Monthly | 32 | Rebuild gear box | 10 Years |

What is safety precaution required for RSU

Before Starting :

- Check drum direction control valve is in Neutral or centre position
- Connect all hydraulic communication hoses
- Check system pressure panel mounted rotary is in fully open position
- Check wireline is properly connected with the measuring head assembly
- Check oil level in the lubricator tank
- Check weight indicator hose, bleed the air and fill with fluid
- Check 4-speed gearbox in neutral position
- Ensure that the drum hand brake is applied
- Check winch unit is properly locked with the deck

At the End of Operation:

- Keep wireline in parking position and lock with the drum
- Lock measuring head assembly in parking position
- Apply brake on the drum
- Fill-in diesel tank
- Clean the unit
- Store all your tools in proper location and in storage bins.

What is potential hazard during handling RSU

- Physical injuries
- Falls
- Hydraulic fluid exposure
- Electrical hazards
- Cable entanglement
- Pressure-related accidents

3/10/24
[Signature]



Draw & name each part of RSU

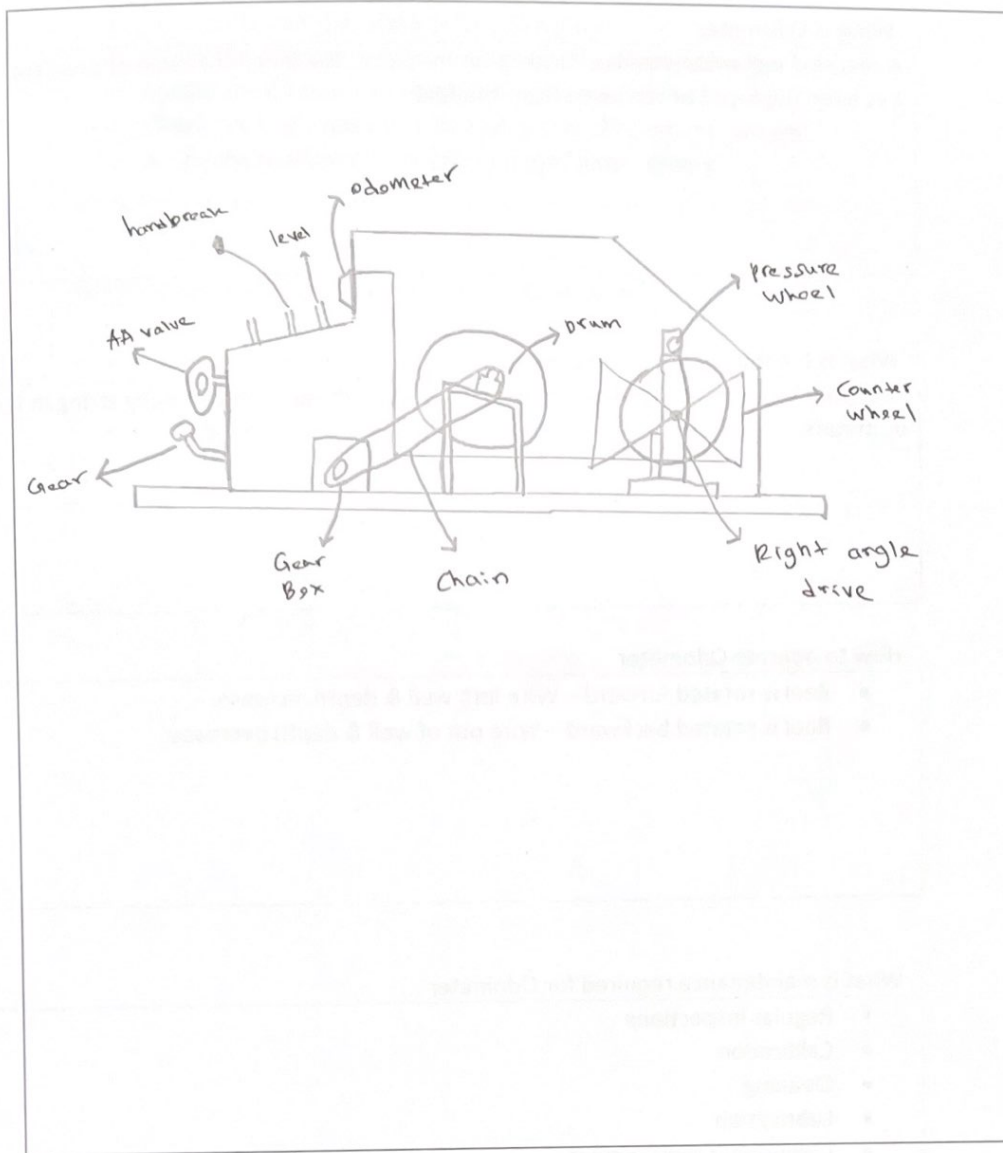

3/10/24



B.6. ODOMETER

What is Odometer

A reel skid unit odometer is a device that measures the length of cable or hose that has been deployed or retrieved from the reel.

What is the purpose of Odometer

Function: To indicate the depth of slickline toolstring hanging in a tubing string in feet or meters.

How to operate Odometer

- Reel is rotated forward – Wire into well & depth increase.
- Reel is rotated backward – Wire out of well & depth decrease.

What is maintenance required for Odometer

- Regular inspections
- Calibration
- Cleaning
- Lubrication
- Component replacement

3/10/24

CONTROLLED COPY



What is safety precaution required for Odometer

Before use, odometer should be checked as follows:

- a. Ensure the counter wheel is free to rotate.
- b. Check the rotation is being transmitted freely to odometer.
- c. Ensure the direction of rotation is correct.
- d. Check the cable has no kinks as it passes through the system.
1. e. Check the odometer is fully engaged after zeroing.

What is potential hazard during handling Odometer

- Physical injuries
- Electrical hazards
- Damage to the odometer
- Interference with other equipment

3/10/24

Draw & name each part of Odometer

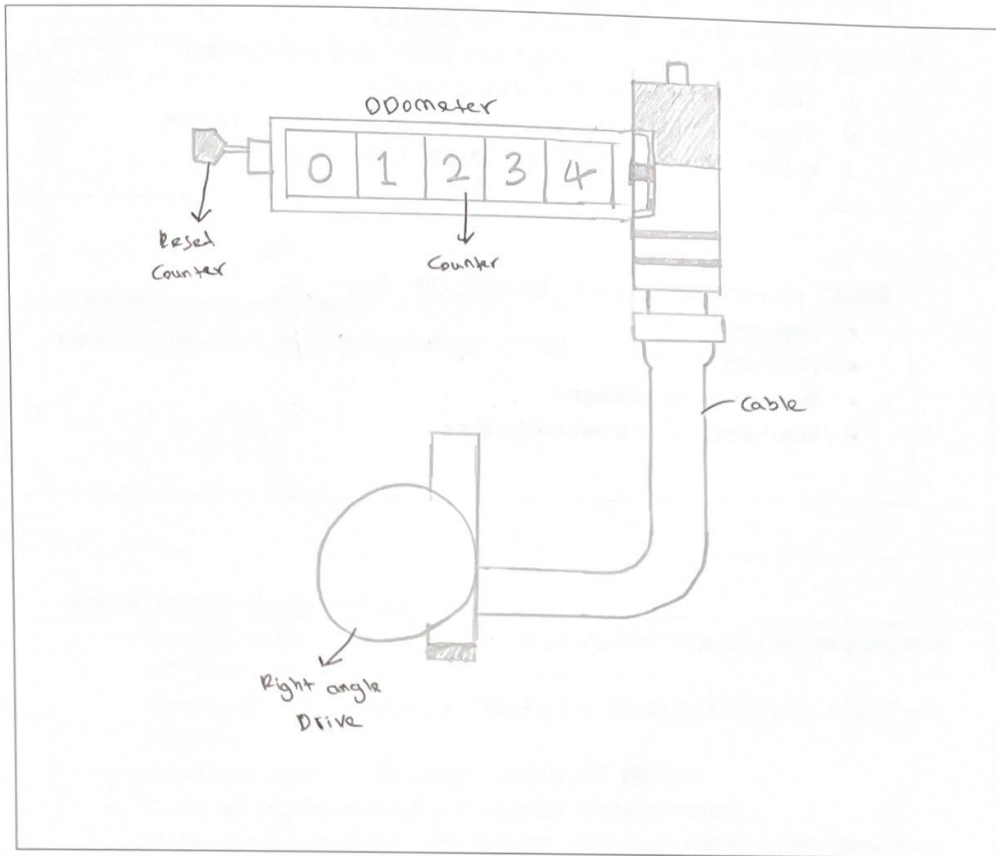

3/10/24

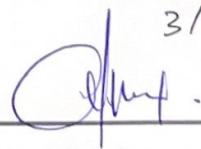



B.7. WEIGHT INDICATOR (200 LBS AND 4000 LBS)

What is Weight Indicator

A weight indicator in a reel skid unit is an instrument used to measure the tension or load on the wireline or cable being spooled or unspooled from the reel.

What is the purpose of Weight Indicator

Function: To determine the total weight of tools hung in tubing string.

How to operate Weight Indicator

- The load cell is connected to the hay pulley and Xmas tree forming a pull at 90°, each side.
- Calibrated in lbs. Available in 2000 lbs (0 – 1000kg), 4000 lbs (0 – 2000 kg), 5000 lbs.
- If the fluid leaks out, the plates of load cell will close.
- If this occurs, the reading on the gauge will be incorrect.
- If the plates close sufficiently to touch, the gauge will no longer show the actual line tension.
- The gap should be approximately 7/16" or 11mm.
- Liquid filled gauge use W-8 fluid.

What is maintenance required for Weight Indicator

- To get the best possible results from weight indicator, it is necessary to completely flush and re-charge the unit at least once per month.
- Having recharged the unit, a specific gap should be set between load plate and load cell retaining ring.

3/10/24



What is safety precaution required for Weight Indicator

- Check calibration before use for accurate readings.
- Inspect the equipment for any damage or wear.
- Mount securely to avoid movement or failure.
- Stand clear of heavy loads during operation.
- Never overload beyond the indicator's capacity.

What is potential hazard during handling Weight Indicator

- Inaccurate readings can cause overloading and equipment failure.
- Electrical shock if wires or components are exposed.
- Crushing injuries from moving parts or falling loads.
- Equipment failure due to poor maintenance or damage.
- Slips and trips around cables or tools during setup.

3/10/24



Draw & name each part of Weight Indicator

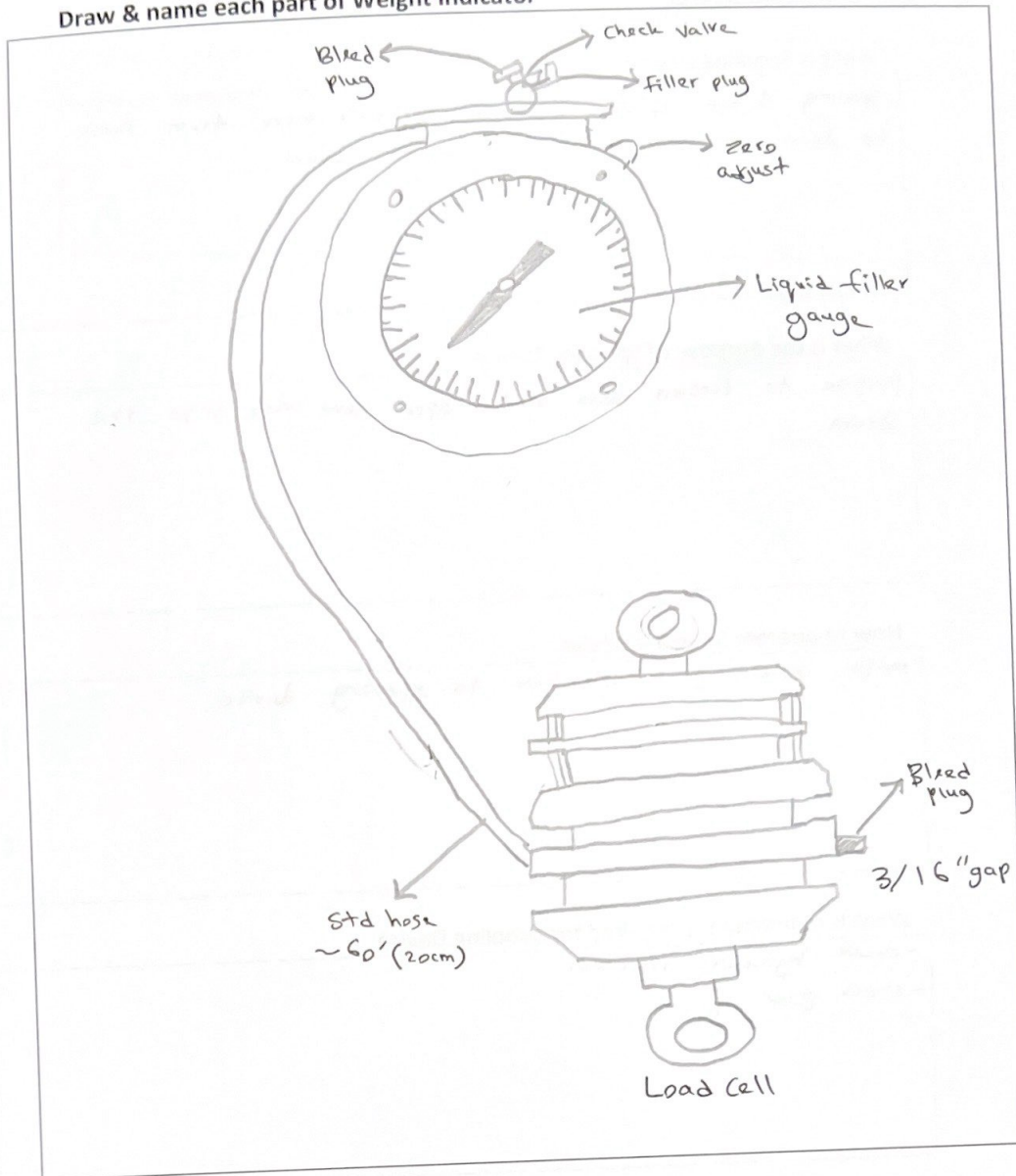

3/10/24



B.8. SPOOLING DEVICE

What is Spooling Device

Spooling device is device to spool new wire from reel to drum or drum wire to another drum.

What is the purpose of Spooling Device

Purpose to tension wire while spool new wire into the drum.

How to operate Spooling Device

Must connect powerpack hose to spooling device.

What is maintenance required for Spooling Device

- check hydraulic regulator
- check gear oil.

What is safety precaution required for Spooling Device

- Barricade work site area
- Full PPE

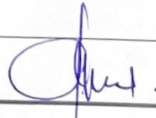
 3/10/24