

SLICKLINE ASSISTANT WORKBOOK

IMPORTANT NOTE:

1. Your point of reference to complete this workbook may be obtained from the following
 - Training Manual and any other training materials provided together with this workbook
 - Your Trainer, Assessor (Slickline Operator), Verifier (FSM) or senior colleagues
 - SOP / Quality Procedures & Processors
2. The completion of this Workbook is a joint effort and responsibility between you and your assessor therefore you have the obligation to request from your assessor to be assessed upon your completion of each topic
3. The completion of this Workbook is part of the MANDATORY requirements which you must fulfill to qualify for a promotion
4. Your training program is mostly self-driven, including this Workbook. It requires individual initiatives, dedication and commitment to complete the process.

NAME	MUHAMMAD AQISH BIN ZAINUDIN
DATE OF JOIN	27.11.2023
CONTACT NO.	01123420735
RECEIVED DATE	27.02.2025
DATE COMPLETED	27.02.2025

B. SURFACE EQUIPMENT

B.1. STUFFING BOX

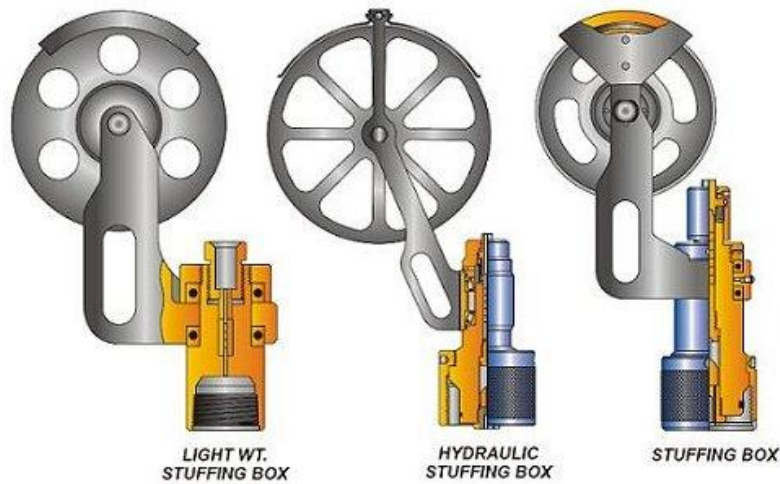

What is Stuffing Box

A primary pressure barrier that positioned at the uppermost point of the PCE string.

What is the purpose of stuffing Box

To ensure sealing off around moving or solid wireline at the upper end of the lubricator during wireline operations.

How to operate Stuffing Box

Stuffing box can be operated either manually or hydraulically without part modification.

What is maintenance required for Stuffing Box

Packings - Not worn out.

Sheave - Use correct size

Upper and lower gland - Check for wear

BOP plunger - Check for wear and freedom of vertical movement

Sheave bearings - Check for free spinning

Sheave staff - Check for freedom of swivel movement

Sheave guard - Tight and adjusted close to the sheave

What is safety precaution required for Stuffing Box

Check the packing whether worn out or not

Check out the correct size of the sheave

What is potential hazard during handling Stuffing Box

Drop object

Pinch point

Back injury

Draw & name each part of stuffing box

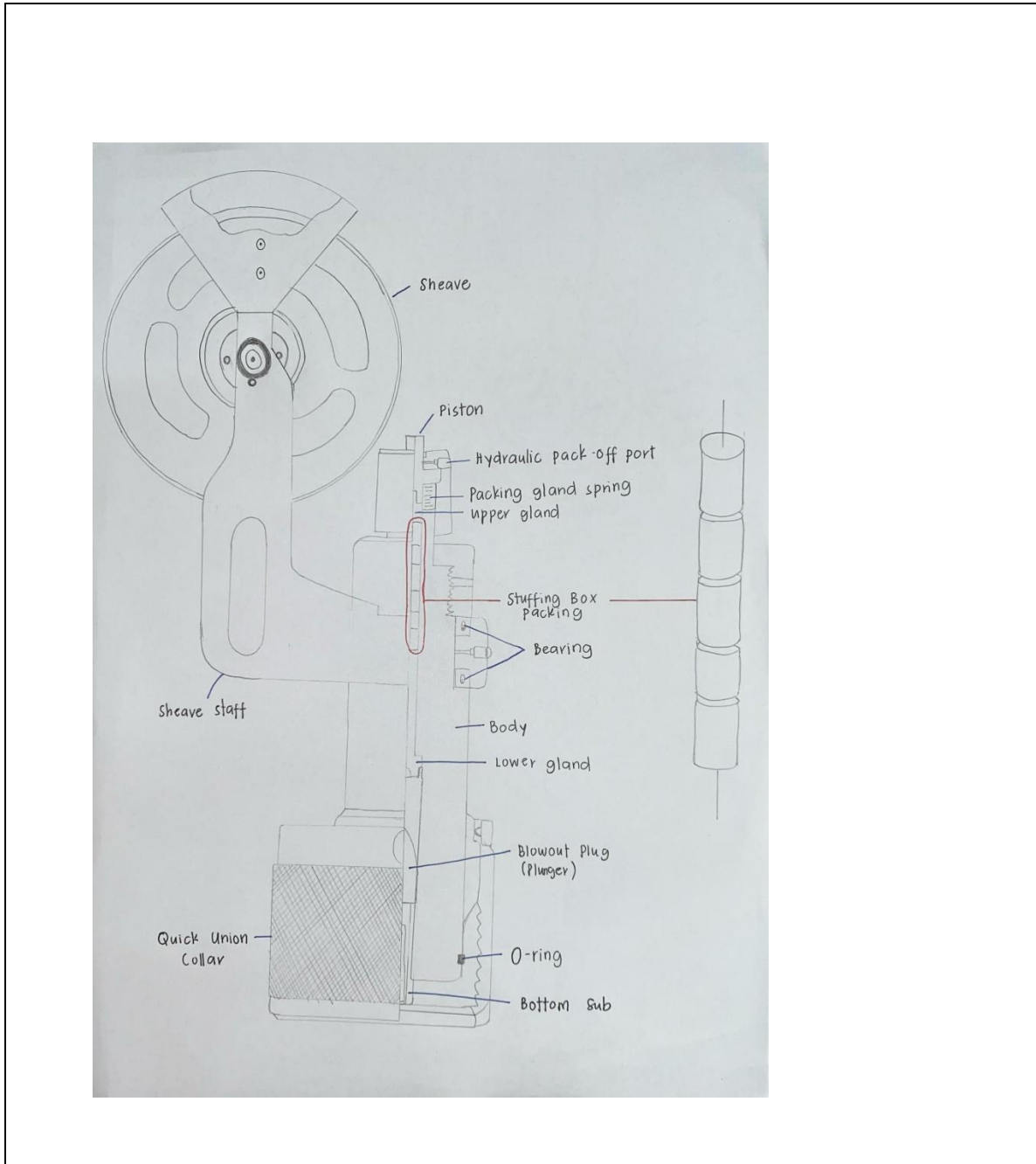

B.2. LUBRICATOR

What is Lubricator

Lubricator is also known as risers are series of inter-connected lengths of pipe. It is a piece of equipment designed to enable wireline tool string to be introduced or retrieve from a wellbore under pressure.

What is the purpose of Lubricator

is to provide a space for the tool to be contained in under pressure, when opening and closing the wellhead

How to operate Lubricator

Connect the lubricator section and rig it up using chain block or wireline mast.

What is maintenance required for Lubricator

Check for any cracks
Visually inspect at the regular interval
Check all the o-ring and make sure that it didn't worn out.

What is safety precaution required for Lubricator

One of the lubricator must have a port to bleed of pressure
Make sure the lubricator validity date is still valid before use.

What is potential hazard during handling Lubricator

Drop object
Pinch point
Back injury

Draw & name each part of Lubricator

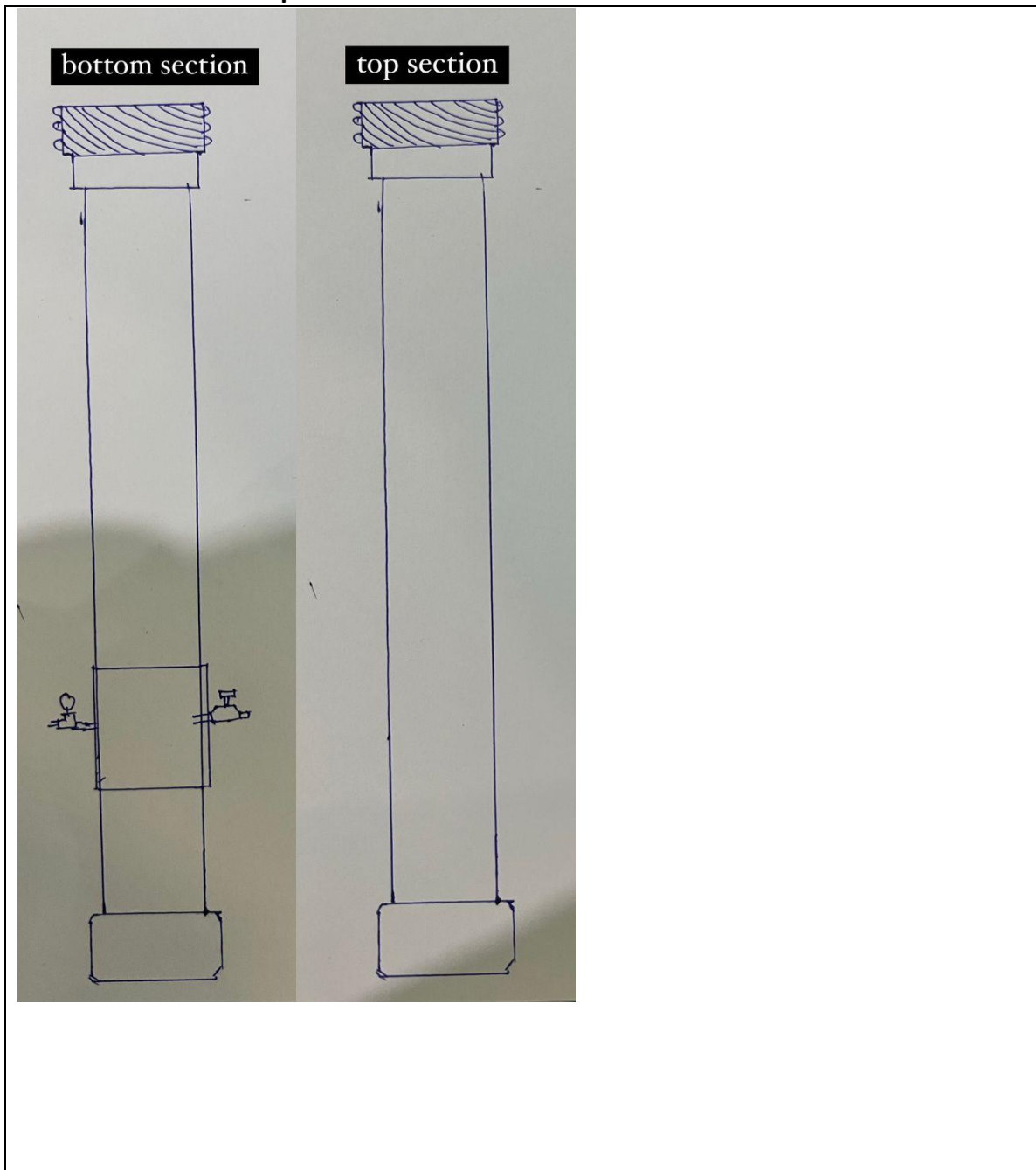

B.3. BLOWOUT PREVENTER (BOP)

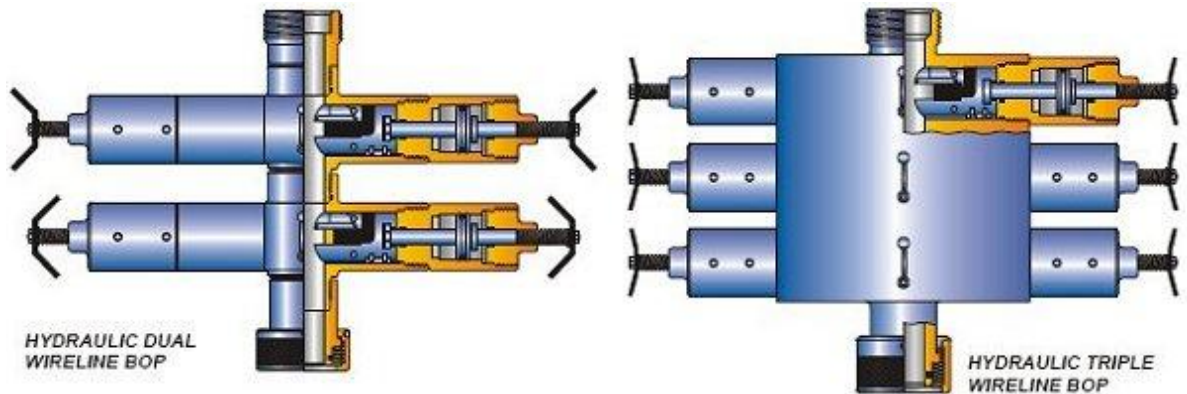

What is BOP

A BOP (also known as a wireline valve) is installed between the tree connection and lower lubricator section

What is the purpose of BOP

Enable the well pressure to be isolated without cutting the wire by closing the master valve.

Permit the assembly of the wireline cutter above the BOP rams and dropping it if the toolstring becomes stuck in the well

Allow slickline work under the well pressure on surface equipment, while wire in the wellbore

How to operate BOP

Hydraulically
Using RSU, control panel

What is maintenance required for BOP

Level 1 Service - To be carried out after every job

1. Wash down
2. Initial inspection - remove rams and cylinders, inspect all seals and sealing surfaces, remove valves and inspect
3. Grease up and rebuild
4. Function and pressure test at working pressure
5. Check lifting gear and record last certification type and date

Level 2 Service - To be carried out once a year

1. Carry out Level 1 service procedure
2. Replace all 'O' rings. Inspecting all components and sealing surfaces for corrosion or damage along the way Pay particular attention to the surfaces below the rams
3. Rebuild Wireline Valve and pressure test to Test Pressure.
4. Function test at Working Pressure

Level 3 Service - To be carried out every 5 years

1. Carry out Levels 1 and 2 service procedure
2. Strip Wireline Valve to component parts discarding all 'O' rings/back-up rings
3. MPI (Magnetic Particle Inspection) of all parts.
4. Rebuild using seal kit and any necessary new parts.
5. Rebuild Wireline Valve and pressure test to Test Pressure
6. Function test at Working Pressure
7. Third party certificate of final test and inspection, certificate of conformity and lifting certification

After each job:

1. Inspect all inner/outer ram seals, O-ring and seals. Replace when showing tear, cut, loss of bond between metal plates and rubber.
2. Install thread protector before storing.
3. Annually or after 10 jobs (whichever comes first), replace all seals in equalizing valve assembly.
4. Annually or after 10 jobs (whichever comes first), inspect hydraulic cylinder assembly and replace all seals.

What is safety precaution required for BOP

Ensure the rod has enlarged diameter below the ram to prevent it being blown out during testing.

What is potential hazard during handling BOP

High pressure
Back injury
Hose burst

Draw & name each part of BOP

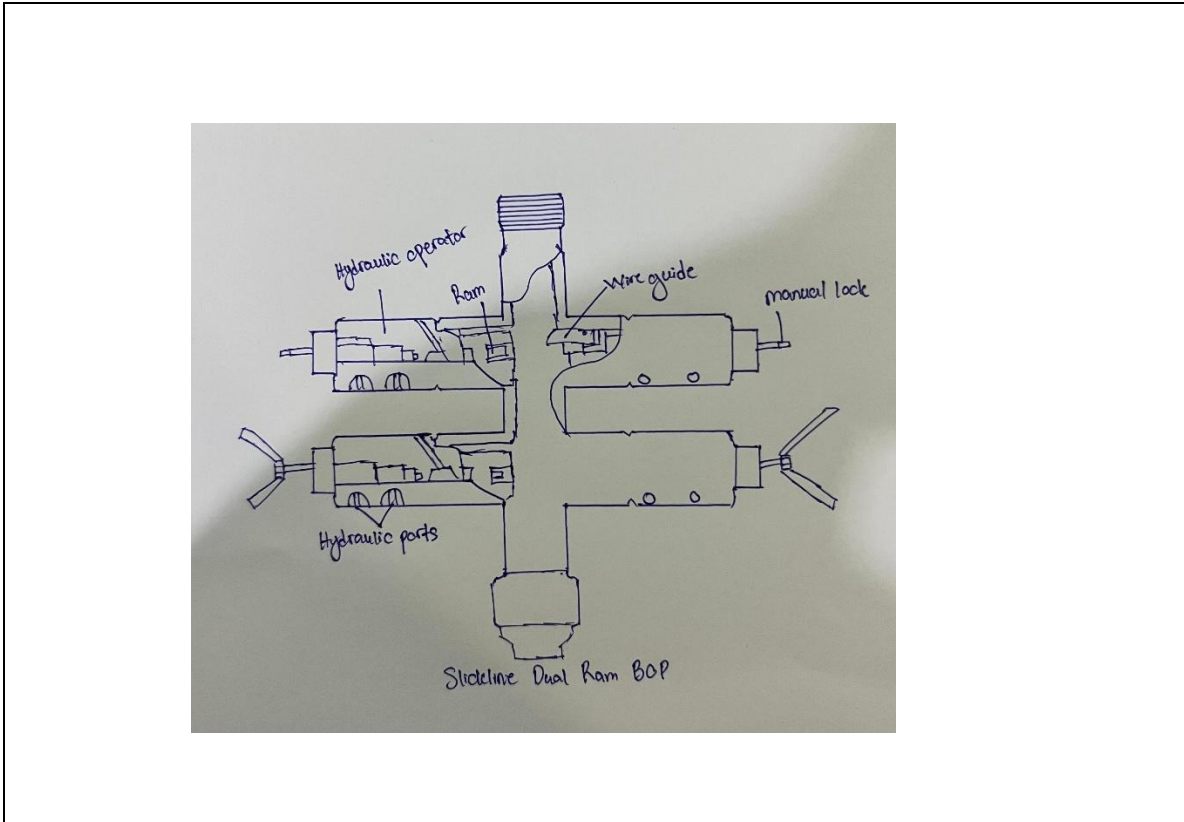

B.4. X-MAS TREE

What is x-mas tree

Xmas tree is a series of valves installed on the wellhead to control the flow of fluids from the well. Located on top of wellhead.

What is the purpose of x-mas tree

Christmas trees are a vertical assembly of valves with gauges and chokes that allow for adjustments in flow control as well as injections to stimulate production

How to operate x-mas tree

The valves that comprise some of the decorations on the Christmas tree are opened when the oil or gas well is ready to produce and the processing and storage facilities are ready to receive.

What is maintenance required for x-mas tree

Inspect and replace any damaged component
Clean X-mas tree and
Do Critical Device Function Test (CDFT) on X-mas tree (check all valves)

What is safety precaution required for x-mas tree

Make a count during opening and closing the swab valve.
Do not overtightened the valves during operation and closing.
Never use master valve to shut in the flowing well, except in an emergency situation.
(use swab or wing valve)

What is potential hazard during handling x-mas tree

- Pinch point
- High pressure
- Work under suspended load
- Line of fire

Draw & name each part of x-mas tree

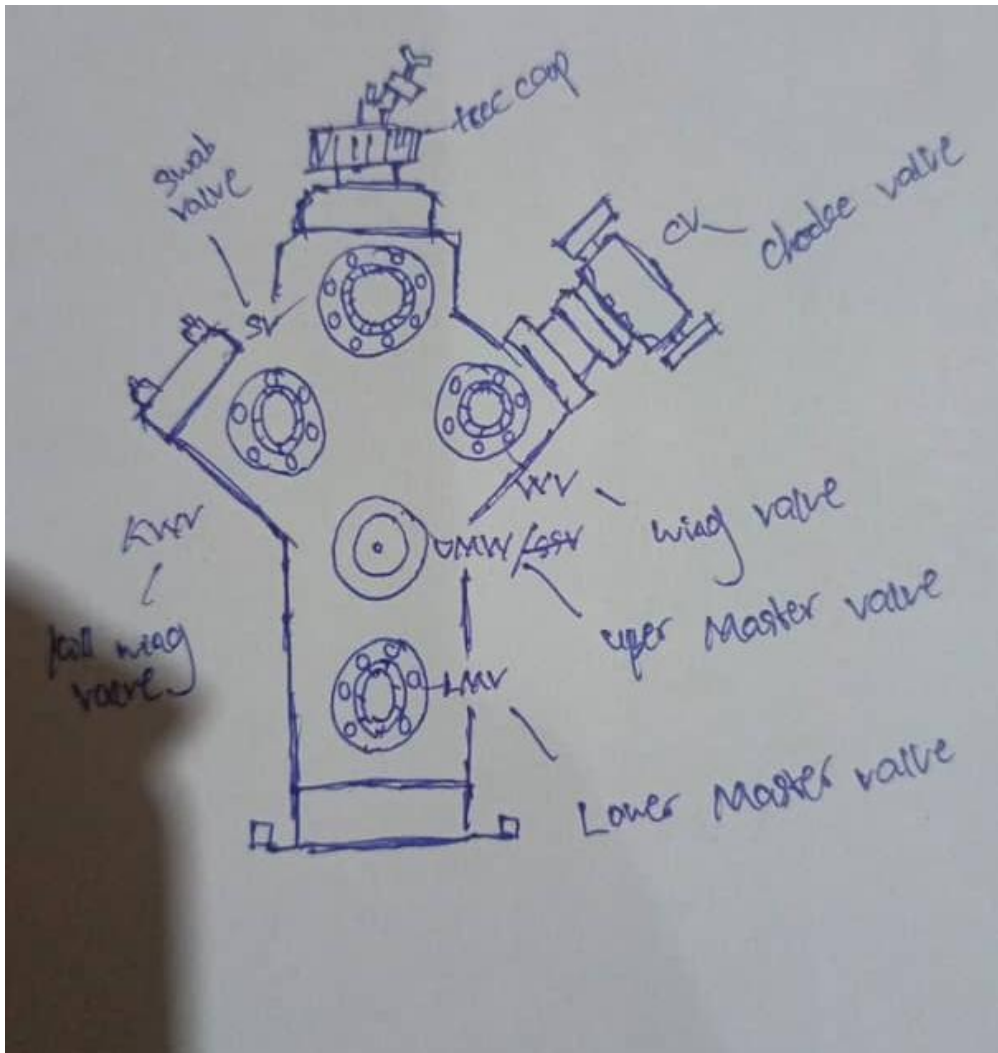

B.5. WIRELINE REEL SKID UNIT (RSU) / WINCH – SINGLE DRUM AND DOUBLE DRUM

What is RSU

RSU is also known as wireline unit or winch which that can control wireline tool strings to go inside the well or pull the tool strings out of the well.

What is the purpose of RSU

It is used to conveys downhole equipment or tools in and out of the wells. It can turn the wire drum to lower and rise tool strings in the wells that require wireline servicing.

How to operate RSU

By using power pack and winch hydraulic system
Transmission of hydraulic hole via hole between power pack / RSU

What is maintenance required for RSU

Replace measuring & pressure wheel, adjust & lubricate drum drive chain, adjust break linkage, inspect drum RPM and compare design data, calibrate mechanical depth counter, calibrate mechanical weight indicator and rebuild gear box.

What is safety precaution required for RSU

Be careful with the wire / rotating drum winch when running because it might break.
Be aware of line of fire and hose burst.

What is potential hazard during handling RSU

- Wire breaks off
- Pinch point
- Rotating drum winch
- Line of fire
- Horse burst

Draw & name each part of RSU

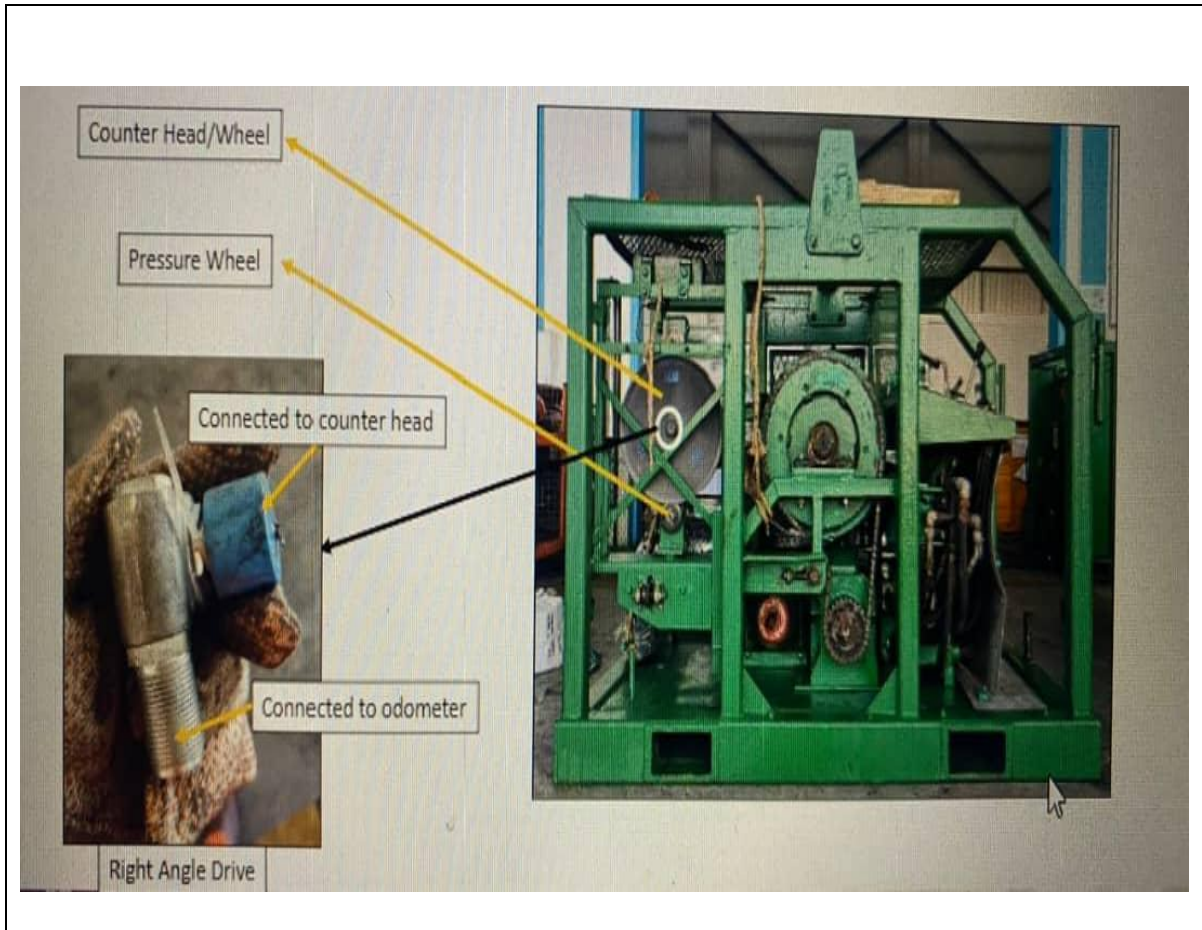

B.6. ODOMETER

What is Odometer

Odometer is a depth measuring device and also known as depth counter

What is the purpose of Odometer

To indicate the depth of slickline toolstring hanging in a tubing string in feet or meters.

How to operate Odometer

Prior to operation, this device should be manually set to zero and start reading from tubing hanger.
Connect hose to right angle drive and put odometer to RSU for monitoring puposes.

What is maintenance required for Odometer

Calibrate mechanical depth counter to get true reading.
Replace the pin if needed
Replace the counter cable if needed
Replace the right angle drive if needed

What is safety precaution required for Odometer

Wear appropriate PPE such as hand glove to prevent from finger injury due to sharp edges or pinch point.

What is potential hazard during handling Odometer

Sharp edges
Pinch point

Draw & name each part of Odometer

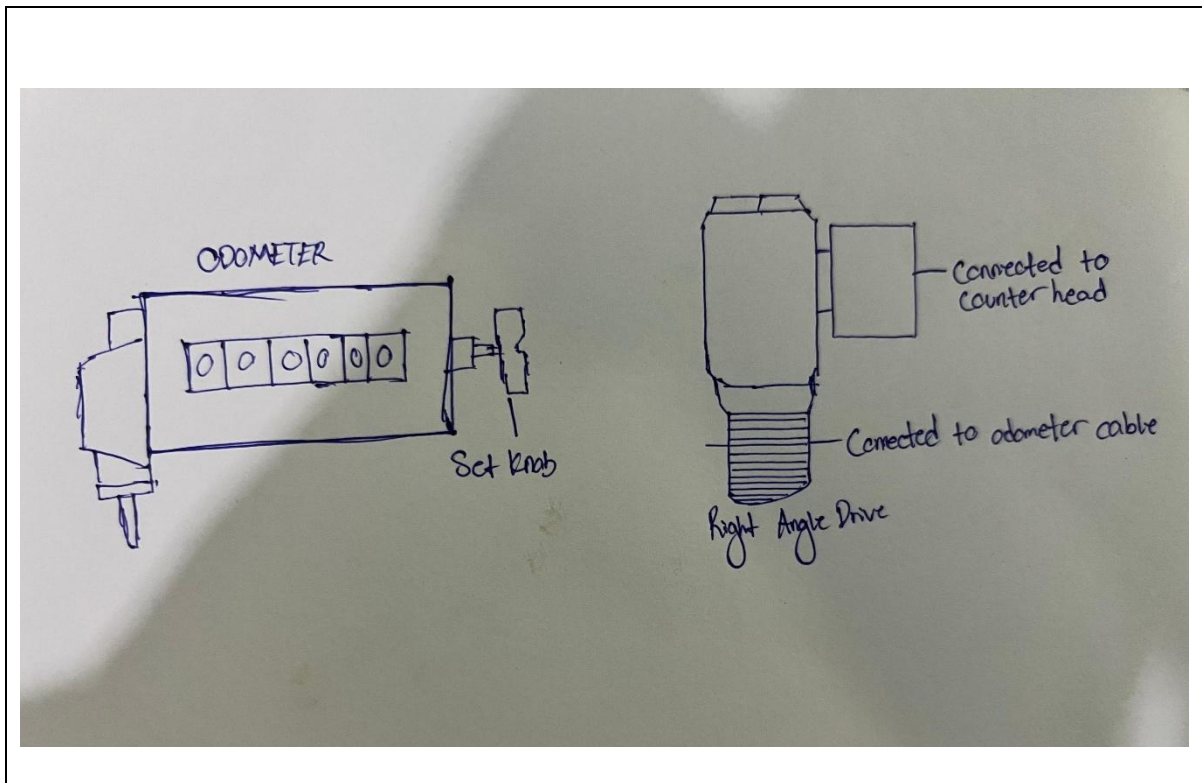

B.7. WEIGHT INDICATOR (2000 LBS AND 4000 LBS)

What is Weight Indicator

Weight indicator is a device to measure weight of tools in tubing string. The device is connected to load cell using a rubber hose filled with hydraulic hose.

What is the purpose of Weight Indicator

To determine the total weight of tools hung in tubing string

How to operate Weight Indicator

The weight indicator (located at RSU) is connected to the load cell using a rubber hose filled with hydraulic oil. Load cell is attached to heavy-duty hose carries the pressure generated to the weight indicator gauge calibrated in lbs.

It is using hydraulic system

What is maintenance required for Weight Indicator

It is necessary to completely flush and re-charge the unit at least once per month. Having recharged the unit, a specific gap (3/16") should be set between load plate and load cell retaining ring.

- Check for leaks around the hose and priming check valve assembly.
- If additional "W-15" fluid is required, fill through the small port on the upper side of the gauge housing.

What is safety precaution required for Weight Indicator

Do not crash the hose

Secure gauge and fittings because the load cell is made of aluminum alloy and reasonably strong rough handling can damage it.

What is potential hazard during handling Weight Indicator

Drop object
If not give attention to weight indicator during operation, might be resulted tension and will cause wireline to break.

Draw & name each part of Weight Indicator

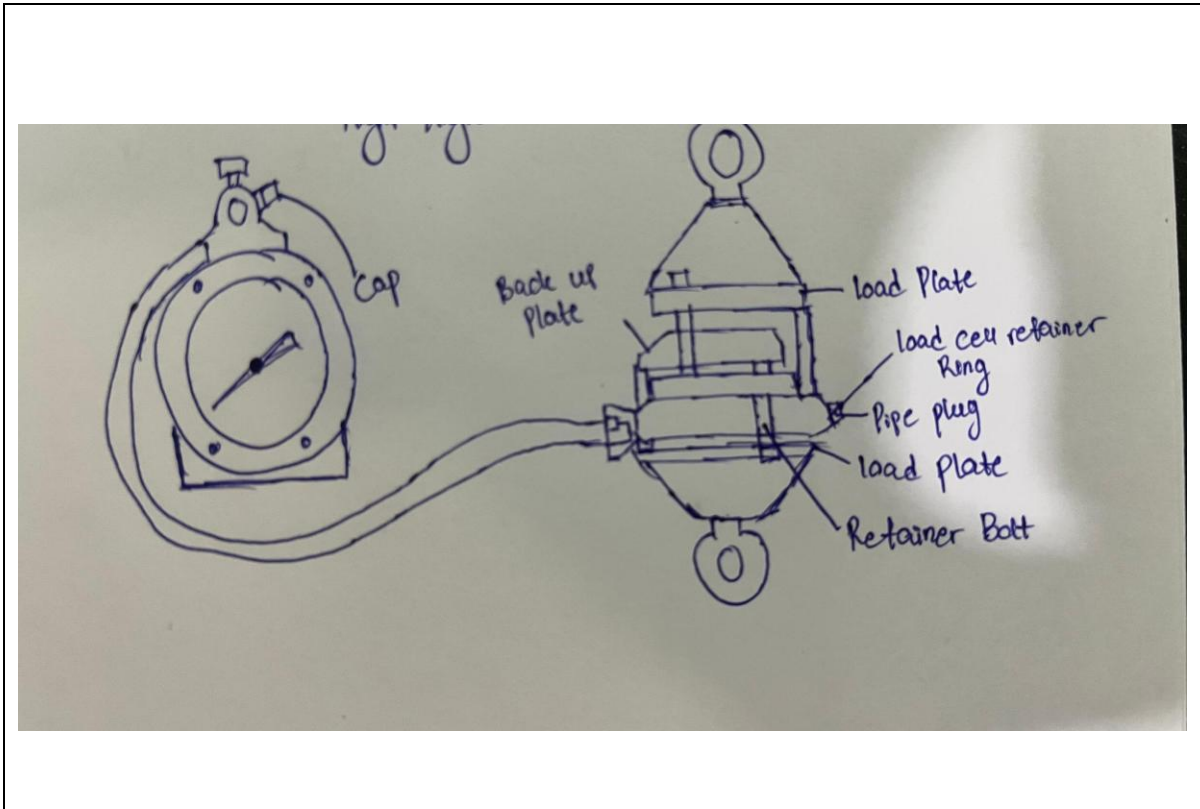

B.8. SPOOLING DEVICE

What is Spooling Device

Generally, one configured with removable drum that allow transport spools to be inserted, allowing the new string to be spooled into reel

What is the purpose of Spooling Device

The purpose is to spool desired wire size/length onto wire drum

How to operate Spooling Device

Assemble the reel. The setup is almost the same with normal operation, which weight indicator and hay pulley are needed
Brake level will help to control the line tension.

What is maintenance required for Spooling Device

Brake maintenance
Always check the hydraulic system

What is safety precaution required for Spooling Device

Make sure to check the glass in good condition before start the job
Bolts and nuts (shaft) are in good condition

What is potential hazard during handling Spooling Device

Pinch point
Rotating device

Draw & name each part of Spooling Device



B.9. CONTROL PANEL

What is Control Panel

Device used to operate BOP, safety valve and other PCE equipments

What is the purpose of Control Panel

Control Panels are used to operate a number of valves normally operated in slickline operations. Their types and its functions are:

- Control Panel (CP) – To operate BOP rams
- Single Well Control Panel (SWCP) – To operate Master Valve and SCSSV
- Well Control Panel (WCP) – An integrated CP that can operate BOP, Stuffing Box, MV & SCSSV

How to operate Control Panel

Connect the control line to the equipment
Open air supply, use regulator to control pump out pressurized the line.

What is maintenance required for Control Panel

Check the fluid level of hydraulic oil
Check the hydraulic hoses for any sign of leakage or damage.

What is safety precaution required for Control Panel

Do not tighten or loose the connection when under pressure
Beware of trapped pressure by bleed off fully before open connection

What is potential hazard during handling Control Panel

Connection loosens
Hose burst by high pressure

Draw & name each part of Control Panel



SWCP



CP



WCP



Air Regulators

B.10. HUSKEL DRUM

What is Huskel Drum

Is an air driver pump

What is the purpose of Huskel Drum

To drive the hydraulic or water in control panel or test pump

How to operate Huskel Drum

Operate from the knob or regulator of the panel

What is maintenance required for Huskel Drum

Check the condition of the O-ring
Service haskel pump
Hydraulic check valve and liquid seal repair

What is safety precaution required for Huskel Drum

Check O-ring condition
Make sure connection tubing is in good condition

What is potential hazard during handling Huskel Drum

Pinch point
Tubing burst

Draw & name each part of Huskel Drum

1.5 hp, 2 & 2.2 hp (1.12, 1.49 & 1.64 kW) Pump Models

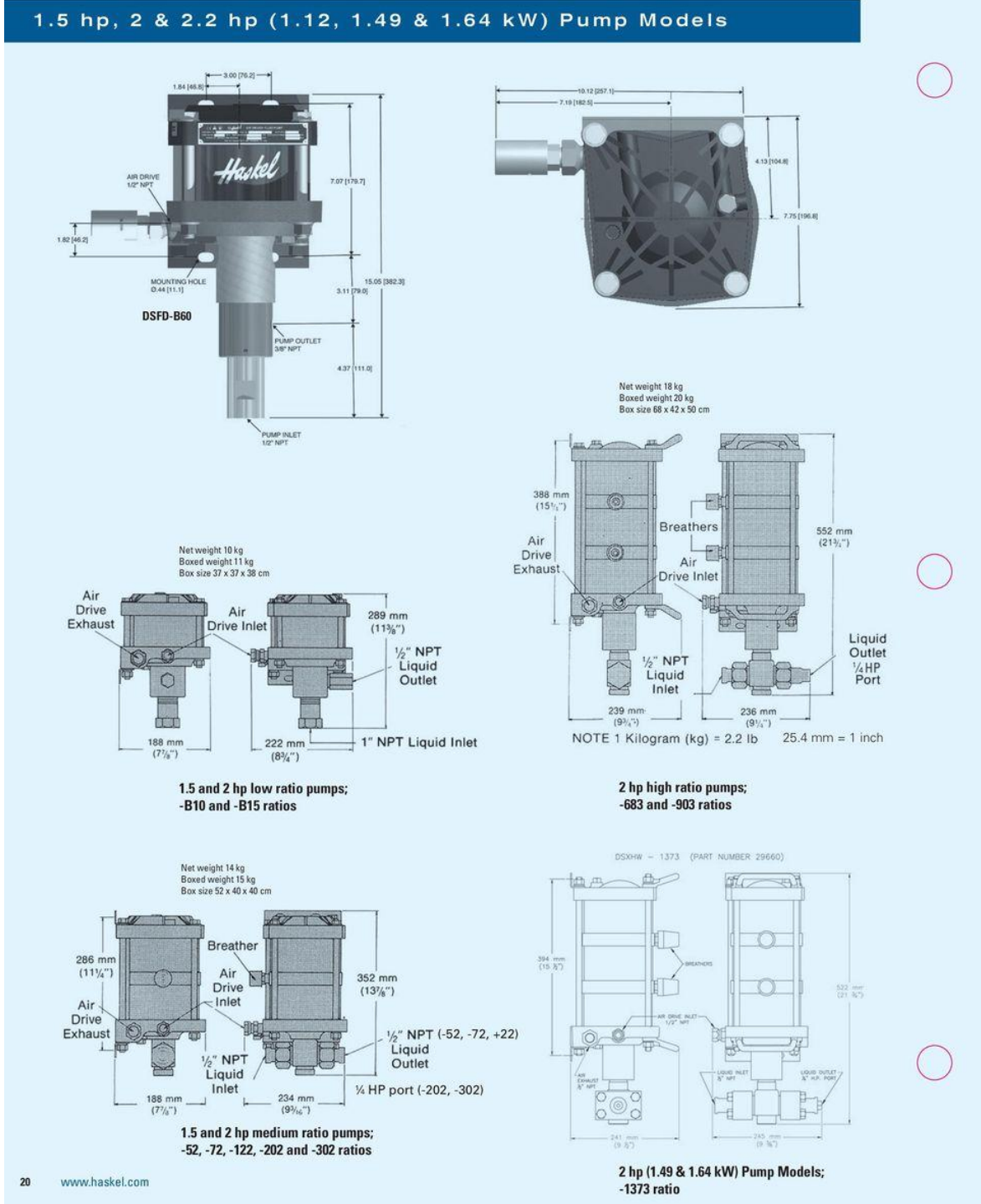

DSFD-B60

Net weight 18 kg
Boxed weight 20 kg
Box size 68 x 42 x 50 cm

**1.5 and 2 hp low ratio pumps;
-B10 and -B15 ratios**

Net weight 10 kg
Boxed weight 11 kg
Box size 37 x 37 x 38 cm

**2 hp high ratio pumps;
-683 and -903 ratios**

Net weight 14 kg
Boxed weight 15 kg
Box size 52 x 40 x 40 cm

**1.5 and 2 hp medium ratio pumps;
-52, -72, -122, -202 and -302 ratios**

**2 hp (1.49 & 1.64 kW) Pump Models;
-1373 ratio**

NOTE 1 Kilogram (kg) = 2.2 lb 25.4 mm = 1 inch

20 www.haskel.com

B.11. POWER PACK (ELECTRICAL & DIESEL)

What is Power Pack

Power pack is hydraulically drive unit powered by diesel engine
Certified with zone 2 equipment

What is the purpose of Power Pack

Provide power to drive hydraulic oil via special hose / hydraulic hose move to drum
at winch
Provide the power (hydraulic) to RSU

How to operate Power Pack

Starting procedure:

1. Keep engine stop cable fully "IN" which is mounted on the control panel.
2. Keep diesel cut off valve in start position.
3. Keep winch unit drum directional control valve in neutral or center position.
4. Start engine by pulling and holding inlet Overspeed shut down valve and depressing the foot/pedal starter switch.
5. Keep and continue holding the inlet Overspeed shut down valve (approx. 10 sec.) until oil pressure is built.
6. Release foot/pedal switch and the inlet Overspeed shut down valve.

During Operation:

1. Check engine oil pressure is correct.
2. Check radiator coolant for any leakage.
3. Run the engine for 5-10 minutes, warm-up period, before putting on duty.
4. Check coolant and hydraulic oil temperature, must not exceed 90 °C.
5. Check hydraulic oil pressure.
6. Note incase of any emergency shut of the engine by actuating the engine stop lever.

What is maintenance required for Power Pack

Check oil level
Check water level
Check diesel level
Check condition of belting
Check any leaking

What is safety precaution required for Power Pack

Wear appropriate PPE when changing hydraulic oil/ engine oil
Beware of rotating fan when engine is running
Do not open radiator cap while power pack is still running

What is potential hazard during handling Power Pack

Hose burst
Hand injury
Rotating fan

Draw & name each part of Power Pack

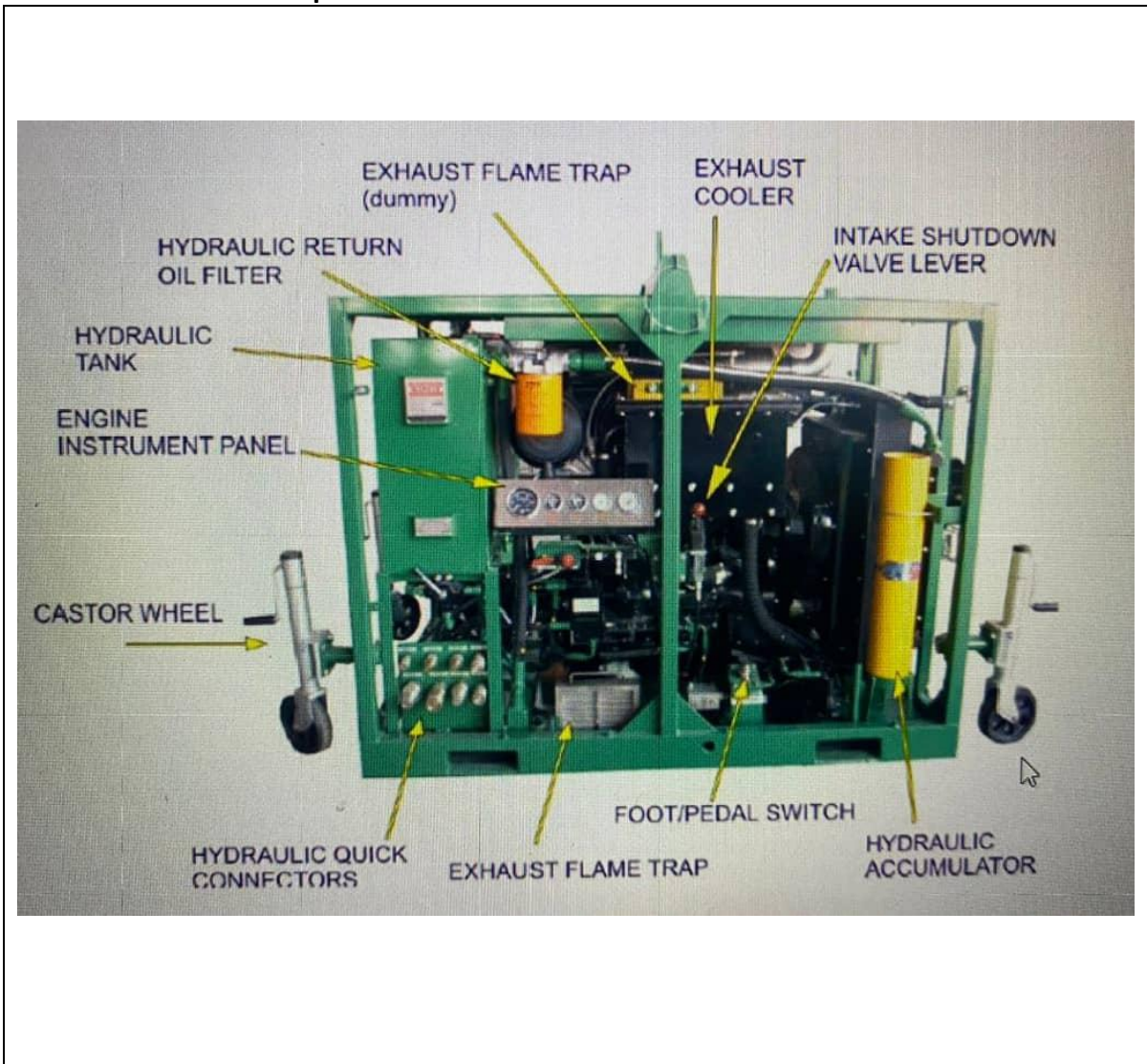

B.12. AIR COMPRESSOR

What is Air Compressor

A machine that air being compressed driven by diesel engine

What is the purpose of Air Compressor

To supply compressed air for control panel, test pump and air stater engine

How to operate Air Compressor

Starting procedure is almost the same with power pack. The air compressor usually use spring starter. To crank the starter, rotate the shaft clockwise until indicator turn red. Replace spring to start the engine

What is maintenance required for Air Compressor

Change filters
Change oil compressor
Check fan belting condition

What is safety precaution required for Air Compressor

Make sure all hoses connection no leaking
Make sure fan is covered

What is potential hazard during handling Air Compressor

Hose burst
Pinch point
Hot surface

Draw & name each part of Air Compressor

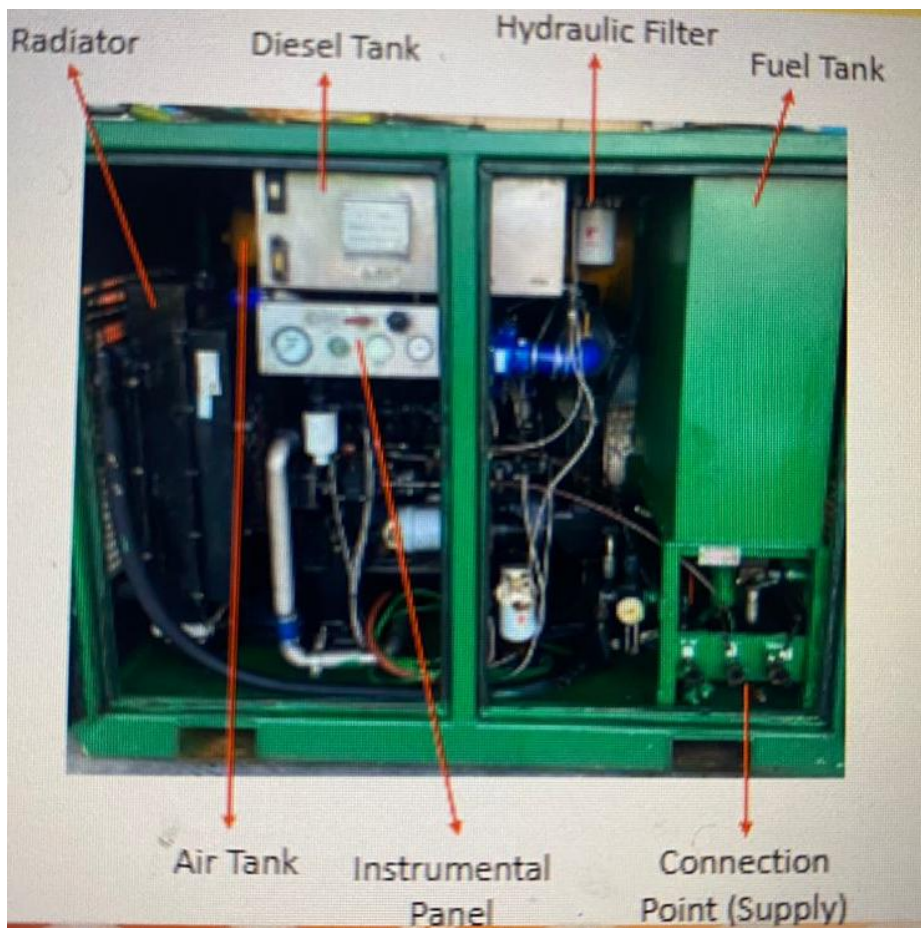

B.13. DRUM

What is the purpose of Drum

To spool the wireline wire

Draw the right and wrong wire arrangement from drum to hay pulley

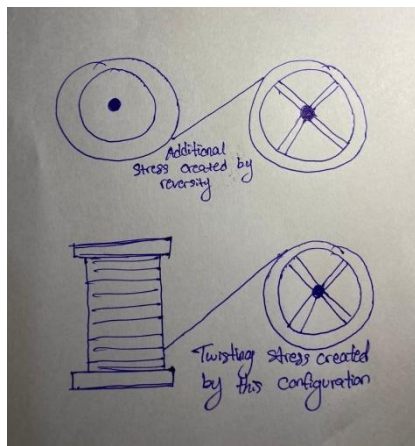

Wrong Method

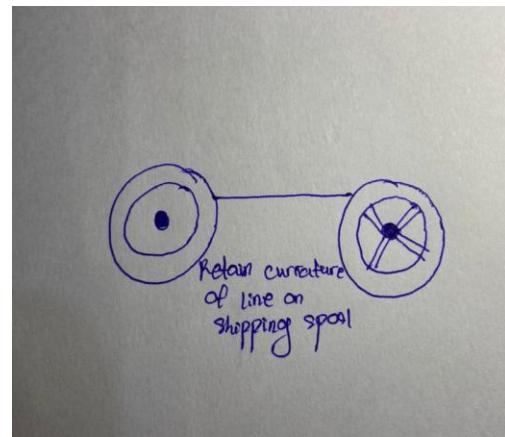

Right Method

What is maintenance required for Drum

Make sure to service and always check the drum bearing, change if there have any broken or damage

What is safety precaution required for Drum

Use tag line or push pull stick
Make sure using the safety glasses and appropriate PPE

What is potential hazard during handling Drum

Rotating device
Pinch point
Back injury

Please draw/sketch the toolstring configuration for:

- 1) Drift run/tubing clearance check
- 2) Sinker bar run
- 3) Set and retrieve plug
- 4) Set and retrieve insert valve

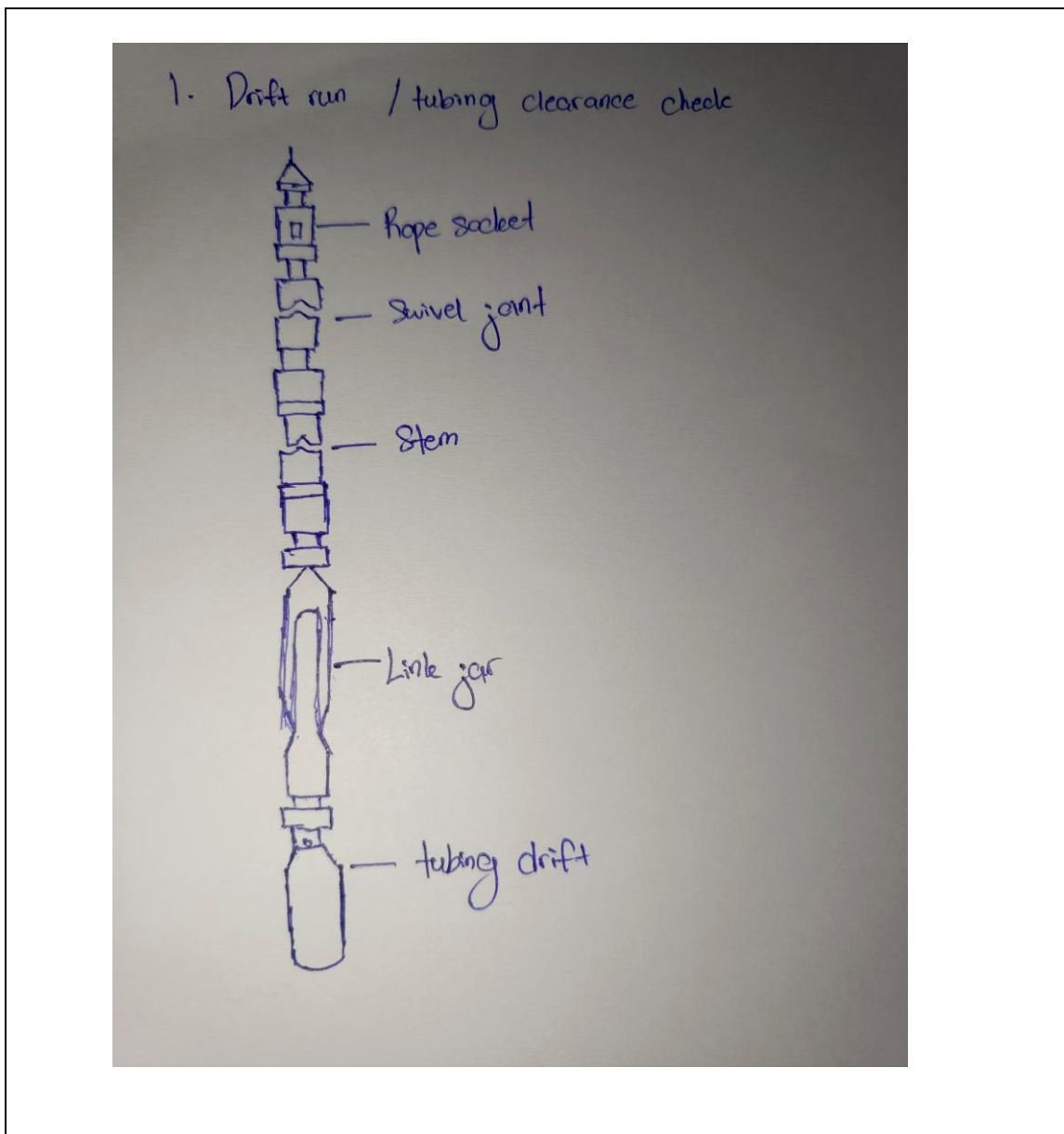

2. Sinker bar run

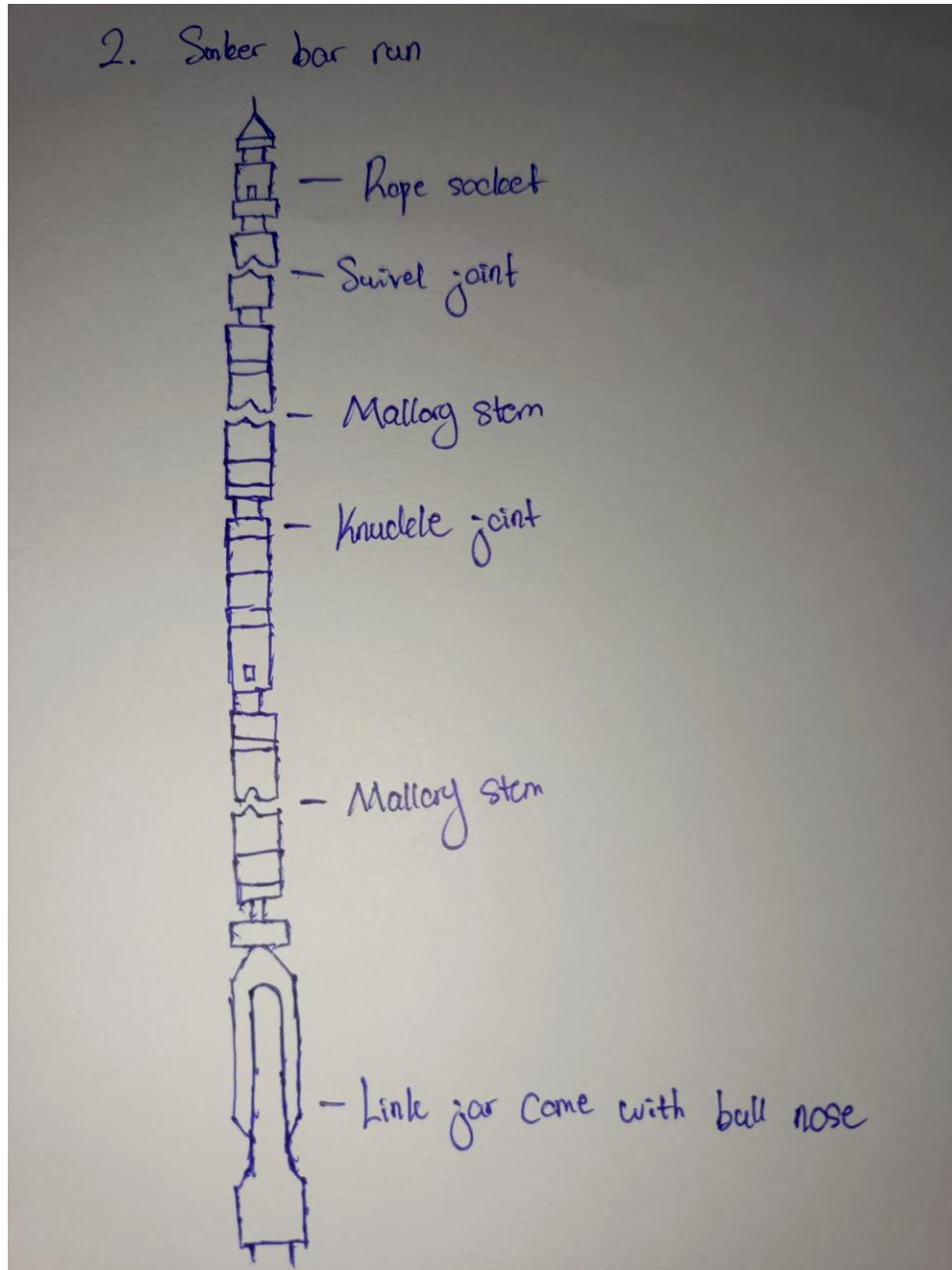

3. Set / Retrieve plug

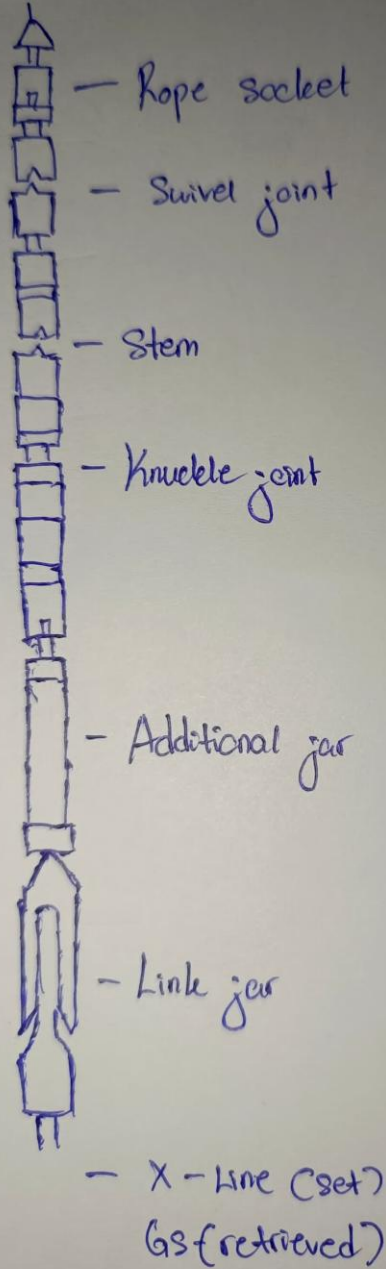

4. Set / Retrieve Insert valve

