

DIMENSION BID

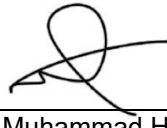

DULANG C-15 L SCO

Revision: 1
Prepared for: Hanisah
Date Prepared: 15th April 2024
Well: C-15L
Field: DULANG
Operation Region: PMA
Prepared by: Muhammad Hafiz
Phone: +6019-2640410
Email: Hafiz.saharuddin@neudimension.com

DESIGN VERIFICATION**PREPARED BY DB**
CTS Operation Engineer_____
Muhammad Hafiz15/4/2024

Date**REVIEWED BY DB**
CTS Technical Advisor_____
Kung Yee Han15/4/2024

Date**APPROVED BY DB**
CTS General Manager_____
Aliff Adenan15/4/2024

Date**APPROVED BY PCSB**
Dulang
Well Intervention Engineer_____
Hanisah_____
Date**APPROVED BY PCSB**
Technical Professional
Well Intervention, PMA_____
Izwan Jalil_____
Date**APPROVED BY PCSB**
Head of Cluster 2
Well Intervention, PMA_____
Hafizi Zaini_____
Date

Remark: Do not execute the procedures in this document if it is not fully approved and signed by all parties.

DISTRIBUTION LIST

No	Personnel	Company	Name	Email
1	Well Intervention Engineer	PCSB	Hanisah	nurhanisah.ahmad@petronas.com
2	Well Service Supervisor (WSS)	PCSB	TBA	TBA
3	Offshore Installation Manager (OIM)	PCSB	TBA	TBA
4	Tech Professional	PCSB	Izwan Jalil	izwanjalil@petronas.com
5	Cluster Head	PCSB	Hafizi Zaini	Hafizi.zaini@petronas.com
6	Head of well Intervention	PCSB	Eddy Samaile	Eddysamaile@petronas.com
7	Material Coordinator (Logistics)	DB – Kemaman	Marzokey	marzokey@neudimension.com
8	Service Supervisor	DB – Kemaman	TBA	TBA
9	Operation Engineer CT Services	DB – Kemaman	Muhammad Hafiz	hafiz.saharuddin@neudimension.com
10	Operation Engineer CT Services	DB – Kemaman	Mohammad Faizal Ali	faizal.ali@neudimension.com
11	Technical Advisor CT Services	DB – Kemaman	Kung Yee Han	yeehan.kung@neudimension.com
12	Field Service Manager CT Services	DB – Kemaman	Mohd Khairul Ridhwan	khairul.ridhwan@neudimension.com
13	General Manager CT Services	DB – Kemaman	Aliff Amirul Adenan	aliff.adenan@neudimension.com
14	HSE Supervisor	DB – Kemaman	Ahmad	ahmad@neudimension.com

DIMENSION BID	DIMENSION BID COILED TUBING SERVICES		
	DULANG C-15L	SCO	

PERSONNEL CONTACT

Any means of following doubt / unusual parameters / Emergency, please contact Dimension Bid personnel in onshore immediately.

No	Name	Position	Company	Location	Contact No
1	Muhammad Hafiz	Operation Engineer	DB	Kemaman	019 – 264 0410
2	Mohammad Faizal Ali	Operation Engineer	DB	Kemaman	013 – 736 1046
3	Kung Yee Han	Technical Advisor	DB	Kemaman	019 – 610 2088
4	Mohd Khairul Ridhwan	Field Services Manager	DB	Kemaman	014 – 515 4452
5	Alif Adenan	General Manager	DB	Kemaman	011 – 1225 7044

REVISION HISTORY

Rev. No	Section	Date	Revised By
0	All	2/4/2024	Muhammad Hafiz
1	Add additional cleanout Run until MA plug and handover to slickline to retrieve plug before proceed with cleanout until EOT	15/4/2024	Muhammad Hafiz

ACRONYM

Acronym	Abbreviation
BHA	Bottom Hole Assembly
RIH	Run In Hole
POOH	Pull Out of Hole
HUD	Hang Up Depth
TCC	Tubing Clearance Check
SCO	Sand Clean Out
TIT	Tubing Integrity Test

BOP	Blow Out Preventer
CT	Coiled Tubing
ID	Internal Diameter
MDTHF	Measure Depth Tubing Head Flange
TOP	Top of Plug
MASTP	Maximum Allowable Surface Treating Pressure
STP	Surface Treating Pressure

Prepared By: Muhammad hafiz	Reviewed By: Kung Yee Han	Date: 15/4/2024	Rev. Rev0	Controlled Document DB-CT-MHS-24006	Pg. 4
--------------------------------	------------------------------	--------------------	--------------	--	----------

TABLE OF CONTENT

DESIGN VERIFICATION	2
DISTRIBUTION LIST	3
PERSONNEL CONTACT	4
REVISION HISTORY	4
ACRONYM	4
TABLE OF CONTENT	5
OBJECTIVES	7
BACKGROUND	7
WELL DATA	8
OPERATION SUMMARY	9
WELL DIAGRAM	10
WELL 3D PLOT	11
TREATMENT VOLUME.....	12
CT STRING INFORMATION	13
CT STRING FATIGUE.....	13
SAFETY OPERATIONAL PROCEDURES.....	15
HEALTH, SAFETY & ENVIRONMENT	16
EQUIPMENT RIG UP PROCEDURE.....	17
EQUIPMENT PRESSURE TESTING PROCEDURE.....	19
OPERATIONAL PROCEDURE	20
CT RUN#1: CLEANOUT UNTIL EOT (2,323 m / 7,622 ft MDTHF).....	20
APPENDIX I – BHA SCHEMATIC	30
BHA#1: 1-11/16 SpinCAT Nozzle	30
APPENDIX II – CT STACK UP.....	31
APPENDIX III – ORPHEUS SIMULATIONS	32
TUBING FORCE ANALYSIS	32
RIH & POOH WEIGHT	32
MAXIMUM STRING PICK UP LIMIT	33
STRING LIMIT	34
SENSITIVY ANALYSIS TFA	35
APPENDIX IV – EMERGENCY PROCEDURE.....	37
EMERGENCY BOP OPERATIONS.....	37
LEAK IN CT AT SURFACE.....	38
LEAK IN CT BELOW SURFACE	38
LEAK IN SURFACE PRESSURE CONTROL EQUIPMENT.....	39

DIMENSION BID	DIMENSION BID COILED TUBING SERVICES		
	DULANG C-15L	SCO	

CT RUNS AWAY INTO WELL 40

CT IS PULLED OUT OF STUFFING BOX..... 41

CT COLLAPSED AT SURFACE..... 41

CT BREAKS AT SURFACE..... 41

BUCKLED TUBING 42

CT STUCK IN HOLE PROCEDURES..... 43

STUCK CT COIL RECOVERY PROCESS..... 45

APPENDIX V – DOWNHOLE TOOL SPECS..... 46

APPENDIX VI – CIRCA SIMULATION..... 47

DIMENSION BID	DIMENSION BID COILED TUBING SERVICES		
	DULANG C-15L	SCO	

OBJECTIVES

1. To perform sand cleanout inside tubing, from slickline latest HUD until EOT

BACKGROUND

Dulang C-15LS was completed with dual string. C015 LS was intermittently flow since March 2017 and shut in since August 2017, well reportedly unstable flow due to gas robbing to short string and liquid too low. String requires sand clean out, zone change to isolate possible water source E12/13 and sand screen installation to revive production from E10/11 sands

Prepared By: Muhammad hafiz	Reviewed By: Kung Yee Han	Date: 15/4/2024	Rev. Rev0	Controlled Document DB-CT-MHS-24006	Pg. 7
--------------------------------	------------------------------	--------------------	--------------	--	----------

DIMENSION BID	DIMENSION BID COILED TUBING SERVICES		
	DULANG C-15L	SCO	

WELL DATA

Input Parameter	Parameter Value
Field	Dulang Charlie
Max. Deviation (degrees)	67.5 degree
Min. Restriction (inch)	2.25" @ No Go nipple
Type of Fluid & Density	Oil
Top of Fluid	TBC
Current Well Status	Idle
Reservoir Pressure	E10/11 (1,531psi)
Fracture Gradient	0.6 – 0.7 psi/ft
H2S Content	N/A
CO2 Content	N/A
Mercury, HG	N/A

Prepared By: Muhammad hafiz	Reviewed By: Kung Yee Han	Date: 15/4/2024	Rev. Rev0	Controlled Document DB-CT-MHS-24006	Pg. 8
--------------------------------	------------------------------	--------------------	--------------	--	----------

DIMENSION BID	DIMENSION BID COILED TUBING SERVICES		
	DULANG C-15L	SCO	

OPERATION SUMMARY

Item	Job Description	Remark
A	CT Operation	<ol style="list-style-type: none"> SCO until MA Plug SSD#4 at depth 2,257 m MDTHF SCO until EOT at depth 2,323 m MDTHF

Prepared By: Muhammad hafiz	Reviewed By: Kung Yee Han	Date: 15/4/2024	Rev. Rev0	Controlled Document DB-CT-MHS-24006	Pg. 9
--------------------------------	------------------------------	--------------------	--------------	--	----------

WELL DIAGRAM

DULANG WELL COMPLETION DIAGRAM

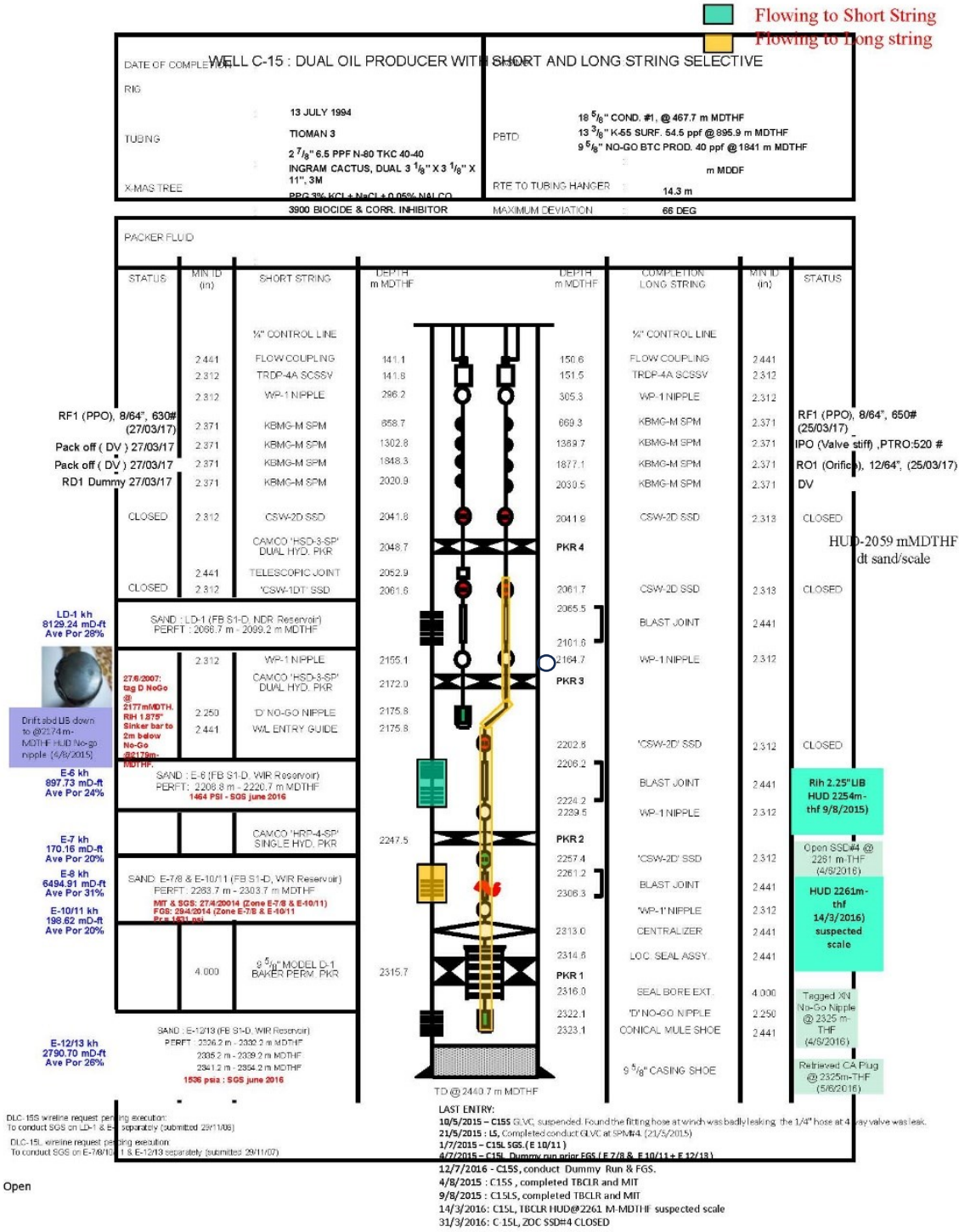

DIMENSION BID	DIMENSION BID COILED TUBING SERVICES		
	DULANG C-15L	SCO	

WELL 3D PLOT

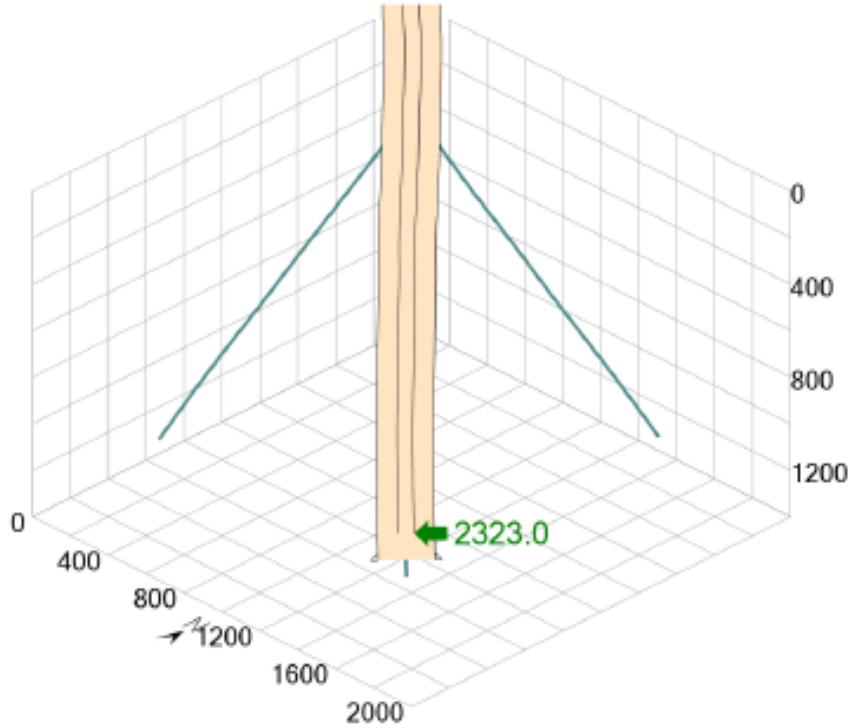

Well name: Dulang C-15 L -TFA (SCO)
 Total depth: 2440.7 m
 Max Inclination: 67.5° at 1069.4 m
 Max DLS: 5.581 °/100ft at 640.8 m
 Min ID: 2.250 in at 2322.0 m

Prepared By: Muhammad hafiz	Reviewed By: Kung Yee Han	Date: 15/4/2024	Rev. Rev0	Controlled Document DB-CT-MHS-24006	Pg. 11
--------------------------------	------------------------------	--------------------	--------------	--	-----------

DIMENSION BID	DIMENSION BID COILED TUBING SERVICES		
	DULANG C-15L	SCO	

TREATMENT VOLUME

Description	Details
Tubing Specification	2-7/8" 6.5 ppf
Production Casing Specification	9-5/8" 40 ppf# N80

Type	Volume															Total Volume (bbls)
	External Pipe			Internal Pipe 1			Internal Pipe 2			Caps	From	To	From	To	Length	
	OD (inch)	ID (inch)	W(lb/ft)	OD (inch)	ID (inch)	W(lb/ft)	OD (inch)	ID (inch)	W(lb/ft)	Barrel/lin (ft)	m	m	ft	ft	ft	
Tubing volume until EOT	2 7/8	2.441								0.00579	0	2,323	0	7,622	7,622	44.12
PCP volume	9 5/8	8.835		2 7/8			2 7/8			0.05977	0	2,048	0	6,719	6,719	401.60

Prepared By: Muhammad hafiz	Reviewed By: Kung Yee Han	Date: 15/4/2024	Rev. Rev0	Controlled Document DB-CT-MHS-24006	Pg. 12
--------------------------------	------------------------------	--------------------	--------------	--	-----------

DIMENSION BID	DIMENSION BID COILED TUBING SERVICES		
	DULANG C-15L	SCO	

CT STRING INFORMATION

OD (in)	Spec	W/T (in)	ID (in)	Length (ft)
1.5	TS-80	0.118	1.264	12,100
CT Volume: 18.8 bbls				

CT STRING FATIGUE

- Current **used life** for Jason #633207 is at **45.29%**

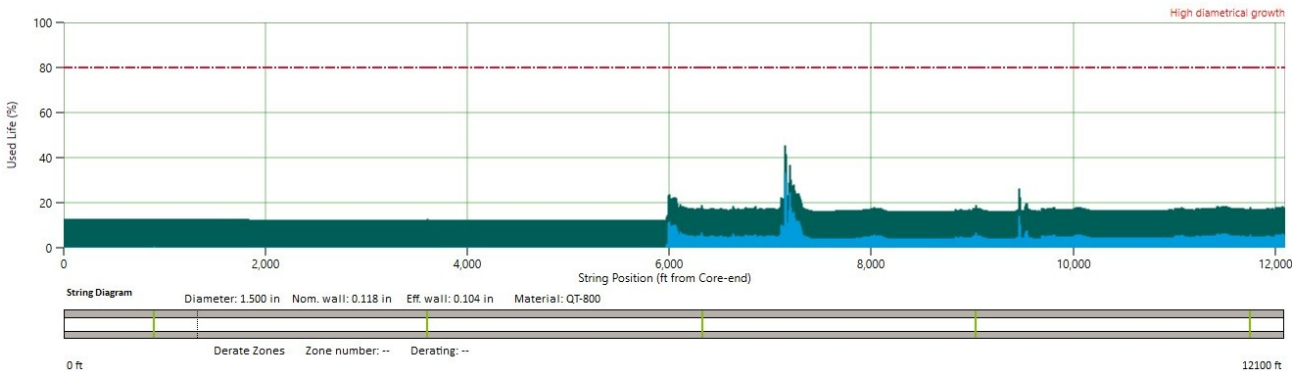

PROCESS FLOW DIAGRAM

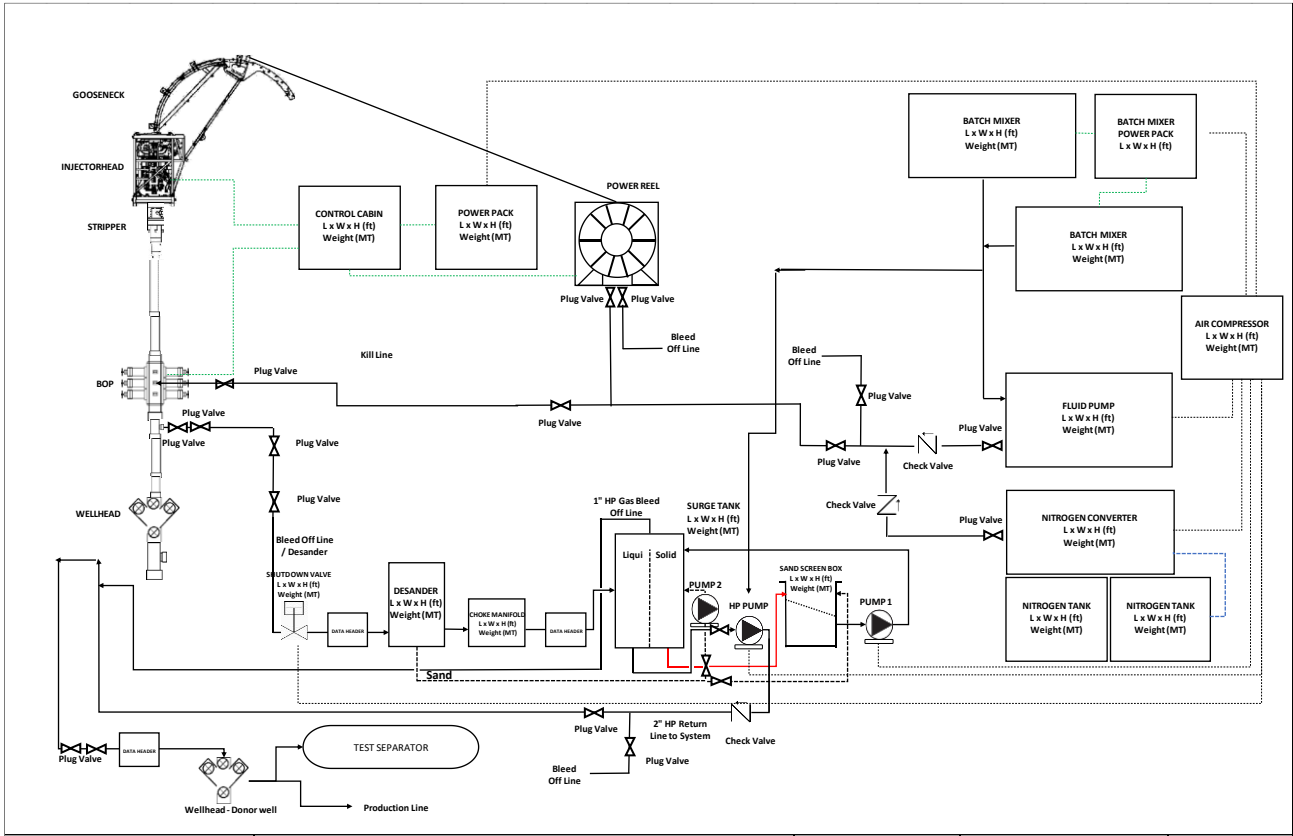

DIMENSION BID

PROCESS FLOW DIAGRAM

CLIENT	PETRONAS CARIGALI SDN. BHD.
WELL NAME	
JOB DESCRIPTION	
REVISION	0

DIMENSION BID	DIMENSION BID COILED TUBING SERVICES		
	DULANG C-15L	SCO	

SAFETY OPERATIONAL PROCEDURES

Prior to commencement of the CT / Bullheading operation, a pre-job meeting will be held. This should be attended by the following parties as a minimum:

OIM, WSS, CT Supervisor, Representatives of other service companies involved and others as necessary.

Safety meetings should be held at the start of every shift and risk assessments must be evaluated during this time. Tool box talks should be held immediately prior to the job execution.

Note: The safety meeting must be driven by DB Supervisor addressing the following topics as a minimum:

1. Muster point.
2. Take list of personnel on site (Head count)
3. All personnel should review and be familiar with escape routes and emergency procedures.
4. Describe the **job objective, fluids and volumes to be pumped, pressures expected** during the job, and others.
5. Review **Dimension Bid Operations Policy and Procedure Manual**.
 - 5.1. Ensure at all steps carried out during the operations comply with this Manual.
 - 5.2. Management of change **MUST** be applied any time there is a need to deviate from the steps contained this procedure.
 - 5.3. A document **MUST** be created describing each the step of the deviation. This document shall also include the deviation Risk Assessment and it **MUST** be approved and signed by PCSB – Head of Well Intervention and Dimension Bid Operations Manager.
6. Exercise Stop work authority if unsafe condition occurs and assess situation with all team members, resume operation after mitigation plan is in place.
7. Personnel responsibilities throughout the job.
8. Spills, fire, blow out, unexpected well behaviour.
9. Emergency shower station and eye wash station location.
10. Trapped potential energy such as pressure or CT stiffness.
11. Prepare related Job Hazard Analysis (JHA) prior commencement of any work, get approval from Client Site Representative (CSR) and review it with all personnel involved as well as to review Risk Assessment.
12. Discuss the well H₂S, CO₂, Hg (Mercury) content (if applicable).
13. Adhere all **PCSB Zeto Rules** and other guidelines.
14. Take a physical count of inventory and make sure all required materials are available on site.
15. **Barricade** the work area and display the appropriate **warning sign**.
16. On chemical mixing and handling; all personnel involved shall hold **safety meeting** and review **Safety Data Sheet** (SDS).
 - 16.1. Personnel involve during chemical handling shall be briefed by DB Chemical Specialist onsite and extra precautions must be taken. All SDS must be available on site and reviewed prior chemical handling.
 - 16.2. All non-essential personnel shall stay away from mixing site.
 - 16.3. Use PPE including respirators, hard hats, eye protection and steel-toed boots.
 - 16.4. Verify if there is any **dead volume** in the mixing tanks and adjust volumes to account for non-usable volume in the blender / mix tank.
 - 16.5. Consider wind direction and note all trip hazards in the mix / pumping area.

Prepared By: Muhammad hafiz	Reviewed By: Kung Yee Han	Date: 15/4/2024	Rev. Rev0	Controlled Document DB-CT-MHS-24006	Pg. 15
--------------------------------	------------------------------	--------------------	--------------	--	-----------

DIMENSION BID	DIMENSION BID COILED TUBING SERVICES		
	DULANG C-15L	SCO	

- 16.6. Prior to mixing chemicals, clean and verify the tank/batch mixer and lines are free of any debris and or contaminants.
- 16.7. In case of spill; wash the place where any chemical has been spilt with available spill kit.
- 16.8. Take care to prevent leakage due to ejection from valves, fittings, flanges, or other joints flexible chemical hoses and pumps. Never repair the equipment during transfer into mixing tank/container.
17. Take reading of Shut in / Flowing Tubing Head Pressure (SI/F/THP), Casing Head Pressure (CHP) and fluid sample (if available) prior to operation.
18. Check gas lift condition and capability with Site Operation Representative (SOR).
19. Ensure fitness prior to perform duties assigned.
20. Ensure all barriers are in place and followed.

HEALTH, SAFETY & ENVIRONMENT

1. Evaluate possible risks to arise during the job execution.
2. Evaluate risk assessment. Report any abnormal or insecure condition on site, taking into account all the steps or procedures to follow. Discuss with PCSB HSE coordinator, the execution or suspension of the job.
3. Review SDS of each product that will be used. Verify that all personnel on location handling toxic or corrosive products have the proper PPE.
4. Review the contingency plan for spills.
5. Do not vent / release any hydrocarbons from the well to atmosphere. Returns from the well should be handled safely by Flowback Company.
6. Prior to DB personnel walking on upper deck, DB Supervisor to inspect upper deck and ensure that the area it is in good condition (Gratings, Hatches, etc.)

Prepared By: Muhammad hafiz	Reviewed By: Kung Yee Han	Date: 15/4/2024	Rev. Rev0	Controlled Document DB-CT-MHS-24006	Pg. 16
--------------------------------	------------------------------	--------------------	--------------	--	-----------

DIMENSION BID	DIMENSION BID COILED TUBING SERVICES		
	DULANG C-15L	SCO	

EQUIPMENT RIG UP PROCEDURE

Conduct safety meeting with all personnel on location detailing the program, pressure limitations, and personnel responsibilities, well control emergency drill and safety precautions.

1. Spot the equipment accordingly to space availability, ensure reel position is aligned with the well.
2. Spot jacking frame at available space with sufficient height and crane capacity to rig up the injector head and gooseneck.
3. Rig up the 4" LP hoses from fluid storage tanks to batch mixer and single pump unit
4. Rig up 2" HP treating line as per DB Technical Standard from single pump unit and N2 converter unit to CT reel manifold. Include bleed off line on both lines as well.
5. Install correct wellhead crossover on the wellhead. Ensure well is fully secure and record the MV and CV turns.
6. Install Blowout Preventer (BOPs):
 - 6.1. Rig up Single BOP with necessary length of risers on top of the wellhead crossover.
 - 6.2. Rig up Combi BOP with flow tee above the risers
 - 6.3. Hook up BOP hoses and conduct function test for each ram.
7. Rig up 2" kill line from single pump unit line to BOP kill port.
8. Rig up flow back line from flow tee to Choke manifold -> desander unit -> High pressure flowback pump -> Donor Well (Refer process flow Diagram)
9. Spot injector head assembly (c/w stripper) with jacking frame on top of wellhead area. Ensure the gooseneck is aligned with the reel position
10. Inspect the chain and gripper block condition and ensure the alignment is correct
11. Rig up the following hydraulic hoses:
 - 11.1. From CT Power Pack to CT Control Cabin
 - 11.2. From CT Power Pack to CT Injector hose reel
 - 11.3. From CT Control Cabin to CT Reel
 - 11.4. From CT Control Cabin to CT BOPs
 - 11.5. From CT Power Pack to Jacking Frame
12. Perform EMC 1 for all equipment. Start up and run all equipment for few minutes.
13. Jack up CT control cabin.
14. Function test both BOP rams.

*Observe indicator pin to confirm that all rams are in good working condition.
15. Install the stab-in-guide on the CT then stab the string into injector head.
16. Record the total cut length of CT String in Cerberus and Pipe Management for future reference.
17. Make up the CT connector and perform pull test at least 15,000 lbs as per DB SOP. This test to be recorded in OrionNET.

*Do not perform pull test more than 80% from CT Limit.
18. Install pressure test plate onto the CT connector.
19. Circulate the string with water until clean return is seen prior to proceed with pressure test CT Connector.
20. Pressure up the CT string to 5,000 psi gradually by 500 psi increment then hold for 10 minutes.

Prepared By: Muhammad hafiz	Reviewed By: Kung Yee Han	Date: 15/4/2024	Rev. Rev0	Controlled Document DB-CT-MHS-24006	Pg. 17
--------------------------------	------------------------------	--------------------	--------------	--	-----------

21. Open the needle valve to release the pressure slowly.
22. Flush coil to ensure there is no debris/metal inside the treating line or coil, and perform Coil pickling (if required with 7.5% HCl).

Notes: All acid will be neutralized at surface line before flowback to system.

23. Make up the BHA onto the string as per BHA diagram provided.
24. Use the jacking frame to pick up the injector and risers then connect to the Combi BOP. Secure down the injector assembly with chains.
25. Measure the following length to set the CT depth:

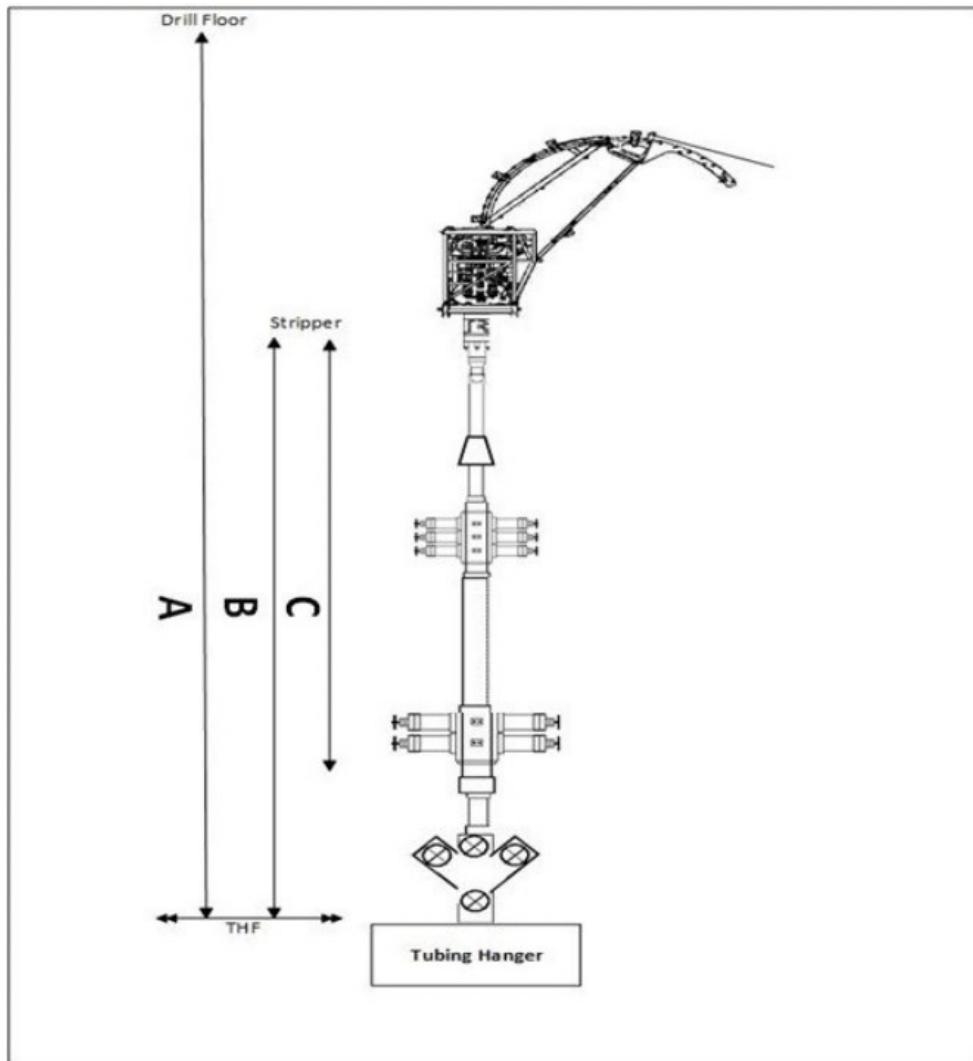

Distance	Length (ft)
A: Tubing Hanger (THF) to RKB	
B: Tubing Hanger (THF) to Stripper	
C: BHA Length	

26. Pick up CT and tag the stripper to set CT depth based on this calculation "A-B+C".

DIMENSION BID	DIMENSION BID COILED TUBING SERVICES		
	DULANG C-15L	SCO	

EQUIPMENT PRESSURE TESTING PROCEDURE

Conduct safety meeting with all personnel on location detailing the program, pressure limitations, and personnel responsibilities, well control emergency drill and safety precautions. Refer the following procedure to pressure test BOP Body, Blind Ram, Surface Line and Wellhead connection.

1. Isolate the line to CT. Double confirm the valve is closed.
2. Fill and pressure test the treating line with water to 500 psi and hold for 5 minutes. Inspect the lines for leaks and observe for any pressure drop.
3. Increase pressure to 3,000 psi and hold for 10 minutes. Inspect the lines for leaks and observe for any pressure drop.
4. Fill the pressure control equipment and ensure air is vented from the system by leaving the blind ram and blind ram equalizing valves open.
5. Close blind ram and equalizing valve. Pressure up the surface lines, BOP body, blind rams and wellhead connection to 500 psi then increase gradually to 3,000 psi through the kill line, hold for 10 minutes. Inspect the lines for leaks and observe for any pressure drop.
6. Once test complete, open blind ram pressure equalizing port then bleed off any residual pressure and open the blind rams.

Conduct safety meeting with all personnel on location detailing the program, pressure limitations, and personnel responsibilities, well control emergency drill and safety precautions. Refer the following procedure to pressure test BOP Body, Blind Ram, Surface Line and Wellhead connection.

1. Fill up the CT string and stack up until leak can be seen at stripper.
2. Energize the stripper and begin pressure test the complete stack up (CT string, stripper, CT stack and risers) to 3,000 psi against Crown Valve, hold for 10 minutes.
3. Bleed off pressure inside stack up to 1,500psi and bleed off pressure inside CT to 0psi immediately to test the Double Flapper Check Valve with DP of 1,500psi and hold for 10 minutes.
4. Bleed off the pressure from BOP kill port side.
 - *Step 4-8 can be neglected if pipe ram has been pressure tested prior to the job.
5. Place CT string across pipe ram then close the ram.
6. Open pipe ram equalizing valve then fill up the BOP slowly.
7. Close the equalizing valve and begin pressure test the pipe ram to 3,000 psi, hold for 10 minutes.
8. When the tests are complete, bleed off the pressure.

Prepared By: Muhammad hafiz	Reviewed By: Kung Yee Han	Date: 15/4/2024	Rev. Rev0	Controlled Document DB-CT-MHS-24006	Pg. 19
--------------------------------	------------------------------	--------------------	--------------	--	-----------

OPERATIONAL PROCEDURE

CT RUN#1: CLEANOUT UNTIL MA Plug at SSD#4 (2,257 m / 7,405 ft MDTHF)

Conduct safety meeting with all personnel on location detailing the program, pressure limitations, personnel responsibilities, emergency well control drill, and safety precautions.

1. Make up 1-11/16" Spincat as per **BHA#1: 1-11/16" Spincat** in **Appendix 1**.

NOTE: Take the BHA measurement and record in the DOR.

2. Perform function test of the Spincat to determine the pumping parameter. Record the data in the table below, do not exceed 5,000psi.

Flow rates (bpm)	Flowrate (scfm)	Pressure (psi)	Remark
... (as minimum as possible)			
0.3			
0.5			
0.7			
1.0			
1.1			
1.3			
... (as maximum as possible, below 5,000 psi)			

3. Box up to connect the riser and prepare for pressure test.
4. Pick up CT and tag BHA with the stripper.
5. CT stack up pressure test against Wellhead Crown valve. Pumping treated sea water through the CT, apply low pressure test of **300 psi for 5 minutes** and high-pressure test of **3,000 psi for 15 minutes** after stabilization. Record the pressure test. Record test on a chart. Upon successful pressure test, bleed off pressure via Pump-In Sub.
 - 5.1. For low pressure:

Acceptance criteria: No visible leaks. Pressure drop is less than 10% (above 270 psi) over 5-minutes test interval after the pressure stabilizes.
 - 5.2. For high pressure:

Acceptance criteria: No visible leaks. Pressure drop is less than 10% (above 2,700 psi) over the 15- minutes test interval after the pressure stabilizes.
6. Pressure tests the BHA Check Valve. With **3,000 psi** in the CT stack up, bleed off the stack up pressure to **1,500 psi** via pump-in sub; and bleed off pressure in the CT to zero (0) psi via reel manifold.
 - 6.1. Acceptance criteria: **Pressure drop is less than 10% (above 1,350 psi) over the 15- minute test interval after the pressure stabilizes.** Observe for any pressure changes in the stack up. If the BHA check valve is not holding, proceed to replace the MHA; do not RIH with leaking check valve; repeat steps 7 and 8.
7. Upon successful test, bleed off the pressure in the CT stack up to zero through the pump-in sub.
8. Zero both depth counters (Orion and Mechanical) at reference point.
9. Confirm all wellhead and BOP valves are in open position via physical check.

- 9.1. Prior opening the wellhead valve, pressure up above master valves to a pressure equal to the expected shut-in wellhead pressure.
- 9.2. Count and record wellhead valves turns while opening and record it the operation report for reference in future.

CV Opening Turns	LMV Opening Turns

- 9.3. Record initial SITHP and all annulus pressure (PCP, ICP, SCP etc) in the Daily Operation Report (DOR).
- 9.4. Manipulate surface valve to the following position:

Valve	Position
Reel Manifold	OPEN
Flow Cross Return Valve (Cetco lines)	OPEN
Wing Valve	CLOSE

10. Start RIH BHA while pumping TSW at idle rate, once at depth **2,059 m / 6,756 ft**, if still not encounter HUD, start to perform cleanout until MA plug depth at 2,257 m / 7,405 ft MDTHF.
 - 10.1. Refer to CT Tubing Force simulation (Orpheus modelling), refer **Appendix III**.
 - 10.2. Conduct pull test for every 300m (1,000ft) interval, use CT Fatigue graph as reference. [Ensure the CT Fatigue graph is available at location before RIH. Record RIH, Hanging and POOH weight in treatment report.](#)
 - 10.3. Pump drag reducer solution, 2 bbls as lubricant if encounter high dragging (if required).
 - 10.4. Maximum CT RIH speed is **30-50 ft/min/ 9-10m/min**.
 - 10.5. Slow down coil speed to **10 ft/min/ 10m/min**, 50 ft / 15m before and after passing through completion accessories.
 - 10.6. Closely observe weight indicator in control cabin while RIH.
 - 10.7. Observe return all the times.
 - 10.8. Do not exceed operating safety limits **5,000 psi (Circulating pressure)**.
 - 10.9. If the well condition differs from original job design, contact appropriate personnel in charge before proceeding.
 - 10.10. At all time, while RIH, the injector torque control shall be set at the minimum pressure required to move the CT at specified speed.
11. Once BHA reached 2,059 m (Slickline latest HUD), stop coil and conduct pull test of 10m/30ft and record the pulling weight both static and dynamic. (If encounter early HUD, Pick-up BHA and record the weight parameter).

Depth	RIH weight, lbf	Static weight, lbf	Pick up weight, lbf

12. Continue RIH to tag top of HUD (for the maximum allowable set down weight, refer to the TFA graph, do not exceed 50% from the maximum allowable setdown weight). Run 5 meter below from last slickline HUD, if not tag proceed to pick-up at slickline HUD area and flag the coil.
13. Proceed with Acid Cleanout step as per below: - (Soak 5 bbls of 15% HCl first after soaking, follow with 5 bbls 15% HCl Jetting at HUD depth. Proceed attempt to penetrate with high jetting TSW)

15% HCl				10	BBL	Description
Seq.	Product	Concentration		Volume		
1	Sea Water	419	gptg	176	gals	Base Fluid
2	ACM CORR 400	4	gptg	2	gals	Acid Corrosion Inhibitor
3	MESB NE 200	4	gptg	2	gals	Non-Emulsifier
4	ACM Surf 210	3	gptg	1	gals	Surfactant
5	Ammonium Chloride	417	pptg	175	lbs	Clay Stabilizer
6	ACM Iron 300	25	pptg	11	lbs	Iron Sequestering
7	ACM Iron 200	15	gptg	6	gals	Iron Control
8	33% HCl	419	gptg	176	gals	Raw Acid
9	MESB MS 300	100	gptg	42	gals	Mutual Solvent

Mixing Instruction:

1. Fill up tank with Sea Water.
2. Add additives as per above sequence.
3. Agitate until mixture is homogenous.

Neutralization Fluid				10	BBL	Description
Seq.	Product	Concentration		Volume		
1	Sea Water	976	Gptg	410	gal	Base fluid
2	Soda Ash	500	pptg	210	lbs	Neutralization fluid

Mixing Instruction:

1. Prepare Sea water in the mixing tank.
2. Mix soda ash into tank and agitate until mixture is homogenous.

- 13.1. Upon completion mixing 15% HCl acid, proceed to soaking 5 bbls of 15% HCl on top of the obstruction to loosen the HUD. Pick up CT at least 500m above the obstruction depth to soak the acid for 2 hours. After complete soaking, proceed to jetting with 5 bbls 15% HCl (high rate) if able to pass through, use pump rate recommended by CIRCA to circulate (refer cleanout table in step 14).
- 13.2. If unsuccessful, proceed with high jetting TSW while attempt to penetrate the HUD.
- 13.3. If unable to penetrate, repeat step 13.1 – 13.2 for at least 2 times every time encounter New HUD.
- 13.4. If still unsuccessful in clearing the HUD, flag CT string on surface and POOH to surface. Handover to slickline to perform TCC.
- 13.5. In the event of encounter waxy return at surface, spot 3 drums of Waxclen and soak for 2 hours (pickup to safe depth) before proceed with 13.1.
- 13.6. During circulation, if return is tested to be negative in pH, inject soda ash using chemical injection pump to the surface return line to neutralize the acid.

Notes: if able to pass through for few feet, and re-encounter hard tag again, repeat step Soaking/ jetting with 15% HCl until EOT.

14. Increase Jetting rate and establish circulation

Rate suggest by CIRCA: -

- 0.7 bpm with 300 scfm

Notes:

- **For Gas rate minimum at 300 scfm, maximum up to 4,600 psi circulation pressure.**
- **After establish constant return at surface, divert the flow into surge tank for 15 – 30 minutes, record the volume inside the surge tank to calculate losses rate into reservoir. Repeat this step every time change in choke size (due to several reason such as high and low THP).**
- **Continuously record return volume during cleanout operation. (Record inside improved FDR)**
 - 14.1.1. For the event of lost return, kindly refer to the step below for reference:
 - 14.1.1.1. Check surface flowback back pressure. Must be less than WHP
 - 14.1.1.2. Wait till system stabilizes
 - 14.1.1.3. Check gas lift injection
 - Is it on?
 - Injection pressure > Wellbore pressure?
 - 14.1.1.4. Manipulate choke size
 - 14.1.2. If still no return at surface, pick-up BHA by stages to establish return. (Proposed to depth where returns were previously obtained.
 - 14.1.3. If no return establishes at surface, consult town. (Provide the details of THP, choke size and circulation pressure).
 - 14.1.4. After return establish, RIH to perform cleanout.
 - 14.1.5. At all times, monitor the return pattern, THP and debris sample at surface. (Take note if there any THP drop during penetration).
 - 14.1.6. **If no debris recover at surface while penetrating HUD with fluid return, stop penetration and circulate with Gel and CBU until debris recover at surface.**
 - 14.1.7. **Pump 5 bbls gel to lift the suspected debris to surface.**
 - 14.1.8. **CBU at least 2x Annulus volume at that depth.**
 - 14.1.9. **After confirm there's no longer debris at that depth, proceed penetration.**
 - 14.1.10. **In the event unable to penetrate due to hard solid, slowly increase jetting rate until maximum allowable during penetration (ensure the return always establish at surface), after complete 1 cycle penetration, follow rate suggest by CIRCA to lift up the debris.**

15. Every 30m bite, circulate with 5 bbls of gel, until BHA at MA plug depth 2,257 m / 7,405 ft MDTFH

No.	Stage	Fluid	Liquid Rate (Vary)	Total Liquid	N2 Rate	CT Speed	Duration	Depth	Remarks
			BPM	BBL	SCFM	ft/min	Minute	m	
1	CT at 10 m above HUD	TSW	0.7 - 1		300 (minimum)	0	0	10 m above HUD	Establish return on surface
2	RIH to HUD and Penetrate HUD/Fill	TSW	0.7 - 1		300 (minimum)	10	10	HUD + 30 m	Monitor return & CT weight on surface
3	Circulate	D801 Gel	0.7 - 1	5	300 (minimum)	0	13	Stationary CT	Provide suspension to the fill and lift to surface

DIMENSION BID	DIMENSION BID COILED TUBING SERVICES		
	DULANG C-15L	SCO	

4	Circulation	TSW	0.7 - 1		300 (minimum)	0	30 (expected to arrive at surface)	Stationary CT	Until gel return at surface, once confirm the return is clean, proceed with next step as per below.
Pull Test 10m									
5	RIH to last HUD and Penetrate HUD/Fill	TSW	0.7 - 1		300 (minimum)	10	10	HUD + 30 m	Monitor return & CT weight on surface
6	Circulate	D801 Gel	0.7 - 1	5	300 (minimum)	0	13	Stationary CT	Provide suspension to the fill and lift to surface
7	Circulation	TSW	0.7 - 1		300 (minimum)	0	30 (Expected to arrive at surface)	Stationary CT	Until gel return at surface, once confirm the return is clean, proceed with next step as per below.
Pull Test 10m									
Repeat above step 1 to 7 until reached MA plug Depth, 2,257 m / 7,405 ft MDTHF									
7	Hole Cleaning (Circulate)	D801 Gel	0.7 - 1	20	300 (minimum)	0		Stationary CT	Hole cleaning stage.
8	Bottoms Up (Circulate)	TSW	0.7 - 1		300 (minimum)	0	60	Stationary CT	Hole Cleaning stage.1 Hour CBU
Once completed CBU and clear return is established, flag#2 at surface.									
9	POOH	TSW	0.7 - 1		300 (minimum)	10 – 30		To Surface	Monitor return on surface

16. Once at target depth, flag CT string on surface.
17. Remaining stationary and proceed to pump 20 bbls of gel followed with CBU for 1 hours (as per CIRCA analysis).
18. Once complete CBU, start to wiper trip up and POOH to surface
19. Wiper trip speed suggested base on CIRCA analysis **10 ft/min**, until depth 1,100 m. After that continue to POOH normal speed **30-50 ft/min/ 9-10m/min**.
20. Once at surface, handover to slickline for TCC and retrieve MA plug.

Prepared By: Muhammad hafiz	Reviewed By: Kung Yee Han	Date: 15/4/2024	Rev. Rev0	Controlled Document DB-CT-MHS-24006	Pg. 24
--------------------------------	------------------------------	--------------------	--------------	--	-----------

CT RUN#2: CLEANOUT UNTIL EOT (2,323 m / 7,622 ft MDTHF)

Conduct safety meeting with all personnel on location detailing the program, pressure limitations, personnel responsibilities, emergency well control drill, and safety precautions.

21. Make up 1-11/16" Spincat as per **BHA#1: 1-11/16" Spincat** in **Appendix 1**.

NOTE: Take the BHA measurement and record in the DOR.

22. Perform function test of the Spincat to determine the pumping parameter. Record the data in the table below, do not exceed 5,000psi.

Flow rates (bpm)	Flowrate (scfm)	Pressure (psi)	Remark
... (as minimum as possible)			
0.3			
0.5			
0.7			
1.0			
1.1			
1.3			
... (as maximum as possible, below 5,000 psi)			

23. Box up to connect the riser and prepare for pressure test.
24. Pick up CT and tag BHA with the stripper.
25. CT stack up pressure test against Wellhead Crown valve. Pumping treated sea water through the CT, apply low pressure test of **300 psi for 5 minutes** and high-pressure test of **3,000 psi for 15 minutes** after stabilization. Record the pressure test. Record test on a chart. Upon successful pressure test, bleed off pressure via Pump-In Sub.
- 25.1. For low pressure:
Acceptance criteria: No visible leaks. Pressure drop is less than 10% (above 270 psi) over 5-minutes test interval after the pressure stabilizes.
- 25.2. For high pressure:
Acceptance criteria: No visible leaks. Pressure drop is less than 10% (above 2,700 psi) over the 15- minutes test interval after the pressure stabilizes.
26. Pressure tests the BHA Check Valve. With **3,000 psi** in the CT stack up, bleed off the stack up pressure to **1,500 psi** via pump-in sub; and bleed off pressure in the CT to zero (0) psi via reel manifold.
- 26.1. Acceptance criteria: **Pressure drop is less than 10% (above 1,350 psi) over the 15- minute test interval after the pressure stabilizes.** Observe for any pressure changes in the stack up. If the BHA check valve is not holding, proceed to replace the MHA; do not RIH with leaking check valve; repeat steps 7 and 8.
27. Upon successful test, bleed off the pressure in the CT stack up to zero through the pump-in sub.
28. Zero both depth counters (Orion and Mechanical) at reference point.
29. Confirm all wellhead and BOP valves are in open position via physical check.

- 29.1. Prior opening the wellhead valve, pressure up above master valves to a pressure equal to the expected shut-in wellhead pressure.
- 29.2. Count and record wellhead valves turns while opening and record it the operation report for reference in future.

CV Opening Turns	LMV Opening Turns

- 29.3. Record initial SITHP and all annulus pressure (PCP, ICP, SCP etc) in the Daily Operation Report (DOR).

- 29.4. Manipulate surface valve to the following position:

Valve	Position
Reel Manifold	OPEN
Flow Cross Return Valve (Cetco lines)	OPEN
Wing Valve	CLOSE

- 30. Start RIH BHA while pumping TSW at idle rate, once at depth 2,257 m / 7,405 ft MDTHF or Latest slickline HUD Depth, if still not encounter HUD, start to perform cleanout until EOT at depth, 2,323 m / 7,622 ft MDTHF.
 - 30.1. Refer to CT Tubing Force simulation (Orpheus modelling), refer **Appendix III**.
 - 30.2. Conduct pull test for every 300m (1,000ft) interval, use CT Fatigue graph as reference. [Ensure the CT Fatigue graph is available at location before RIH. Record RIH, Hanging and POOH weight in treatment report.](#)
 - 30.3. Pump drag reducer solution, 2 bbls as lubricant if encounter high dragging (if required).
 - 30.4. Maximum CT RIH speed is **30-50 ft/min/ 9-10m/min**.
 - 30.5. Slow down coil speed to **10 ft/min/ 10m/min**, 50 ft / 15m before and after passing through completion accessories.
 - 30.6. Closely observe weight indicator in control cabin while RIH.
 - 30.7. Observe return all the times.
 - 30.8. Do not exceed operating safety limits **5,000 psi (Circulating pressure)**.
 - 30.9. If the well condition differs from original job design, contact appropriate personnel in charge before proceeding.
 - 30.10. At all time, while RIH, the injector torque control shall be set at the minimum pressure required to move the CT at specified speed.
- 31. Once BHA reached previous MA plug setting depth or Slickline latest HUD depth, stop coil and conduct pull test of 10m/30ft and record the pulling weight both static and dynamic. (If encounter early HUD, Pick-up BHA and record the weight parameter).

Depth	RIH weight, lbf	Static weight, lbf	Pick up weight, lbf

- 32. Continue RIH to tag top of HUD (for the maximum allowable set down weight, refer to the TFA graph, do not exceed 50% from the maximum allowable setdown weight). Run 5 meter below from last slickline HUD, if not tag proceed to pick-up at slickline HUD area and flag the coil.
- 33. Proceed with Acid Cleanout step as per below: - (Soak 5 bbls of 15% HCl first after soaking, follow with 5 bbls 15% HCl Jetting at HUD depth. Proceed attempt to penetrate with high jetting TSW)

15% HCl				10	BBL	Description
Seq.	Product	Concentration		Volume		
1	Sea Water	419	gptg	176	gals	Base Fluid
2	ACM CORR 400	4	gptg	2	gals	Acid Corrosion Inhibitor
3	MESB NE 200	4	gptg	2	gals	Non-Emulsifier
4	ACM Surf 210	3	gptg	1	gals	Surfactant
5	Ammonium Chloride	417	pptg	175	lbs	Clay Stabilizer
6	ACM Iron 300	25	pptg	11	lbs	Iron Sequestering
7	ACM Iron 200	15	gptg	6	gals	Iron Control
8	33% HCl	419	gptg	176	gals	Raw Acid
9	MESB MS 300	100	gptg	42	gals	Mutual Solvent

Mixing Instruction:

1. Fill up tank with Sea Water.
2. Add additives as per above sequence.
3. Agitate until mixture is homogenous.

Neutralization Fluid				10	BBL	Description
Seq.	Product	Concentration		Volume		
1	Sea Water	976	Gptg	410	gal	Base fluid
2	Soda Ash	500	pptg	210	lbs	Neutralization fluid

Mixing Instruction:

3. Prepare Sea water in the mixing tank.
4. Mix soda ash into tank and agitate until mixture is homogenous.

- 33.1. Upon completion mixing 15% HCl acid, proceed to soaking 5 bbls of 15% HCl on top of the obstruction to loosen the HUD. Pick up CT at least 500m above the obstruction depth to soak the acid for 2 hours. After complete soaking, proceed to jetting with 5 bbls 15% HCl (high rate) if able to pass through, use pump rate recommended by CIRCA to circulate (refer cleanout table in step 14).
- 33.2. If unsuccessful, proceed with high jetting TSW while attempt to penetrate the HUD.
- 33.3. If unable to penetrate, repeat step 33.1 – 33.2 for at least 2 times every time encounter New HUD.
- 33.4. If still unsuccessful in clearing the HUD, flag CT string on surface and POOH to surface. Handover to slickline to perform TCC.
- 33.5. In the event of encounter waxy return at surface, spot 3 drums of Waxclen and soak for 2 hours (pickup to safe depth) before proceed with 33.1.
- 33.6. During circulation, if return is tested to be negative in pH, inject soda ash using chemical injection pump to the surface return line to neutralize the acid.

Notes: if able to pass through for few feet, and re-encounter hard tag again, repeat step Soaking/ jetting with 15% HCl until EOT.

34. Increase Jetting rate and establish circulation

Rate suggest by CIRCA: -

- 0.7 bpm with 300 scfm

Notes:

- **For Gas rate minimum at 300 scfm, maximum up to 4,600 psi circulation pressure.**
- **After establish constant return at surface, divert the flow into surge tank for 15 – 30 minutes, record the volume inside the surge tank to calculate losses rate into reservoir. Repeat this step every time change in choke size (due to several reason such as high and low THP).**
- **Continuously record return volume during cleanout operation. (Record inside improved FDR)**
 - 34.1.1. For the event of lost return, kindly refer to the step below for reference:
 - 34.1.1.1. Check surface flowback back pressure. Must be less than WHP
 - 34.1.1.2. Wait till system stabilizes
 - 34.1.1.3. Check gas lift injection
 - Is it on?
 - Injection pressure > Wellbore pressure?
 - 34.1.1.4. Manipulate choke size
 - 34.1.2. If still no return at surface, pick-up BHA by stages to establish return. (Proposed to depth where returns were previously obtained).
 - 34.1.3. If no return establishes at surface, consult town. (Provide the details of THP, choke size and circulation pressure).
 - 34.1.4. After return establish, RIH to perform cleanout.
 - 34.1.5. At all times, monitor the return pattern, THP and debris sample at surface. (Take note if there any THP drop during penetration).
 - 34.1.6. If no debris recover at surface while penetrating HUD with fluid return, stop penetration and circulate with Gel and CBU until debris recover at surface.**
 - 34.1.7. Pump 5 bbls gel to lift the suspected debris to surface.**
 - 34.1.8. CBU at least 2x Annulus volume at that depth.**
 - 34.1.9. After confirm there's no longer debris at that depth, proceed penetration.**
 - 34.1.10. In the event unable to penetrate due to hard solid, slowly increase jetting rate until maximum allowable during penetration (ensure the return always establish at surface), after complete 1 cycle penetration, follow rate suggest by CIRCA to lift up the debris.**

35. Every 30m bite, circulate with 5 bbls of gel, until BHA at EOT depth 2,323 m / 7,622 ft MDTHF

No.	Stage	Fluid	Liquid Rate (Vary)	Total Liquid	N2 Rate	CT Speed	Duration	Depth	Remarks
			BPM	BBL	SCFM	ft/min	Minute	m	
1	CT at 10 m above HUD	TSW	0.7 - 1		300 (minimum)	0	0	10 m above HUD	Establish return on surface
2	RIH to HUD and Penetrate HUD/Fill	TSW	0.7 - 1		300 (minimum)	10	10	HUD + 30 m	Monitor return & CT weight on surface

DIMENSION BID	DIMENSION BID COILED TUBING SERVICES		
	DULANG C-15L	SCO	

3	Circulate	D801 Gel	0.7 - 1	5	300 (minimum)	0	13	Stationary CT	Provide suspension to the fill and lift to surface
4	Circulation	TSW	0.7 - 1		300 (minimum)	0	30 (expected to arrive at surface)	Stationary CT	Until gel return at surface, once confirm the return is clean, proceed with next step as per below.
Pull Test 10m									
5	RIH to last HUD and Penetrate HUD/Fill	TSW	0.7 - 1		300 (minimum)	10	10	HUD + 30 m	Monitor return & CT weight on surface
6	Circulate	D801 Gel	0.7 - 1	5	300 (minimum)	0	13	Stationary CT	Provide suspension to the fill and lift to surface
7	Circulation	TSW	0.7 - 1		300 (minimum)	0	30 (Expected to arrive at surface)	Stationary CT	Until gel return at surface, once confirm the return is clean, proceed with next step as per below.
Pull Test 10m									
Repeat above step 1 to 7 until reached EOT Depth, 2,323 m / 7,622 ft MDTHF									
7	Hole Cleaning (Circulate)	D801 Gel	0.7 - 1	20	300 (minimum)	0		Stationary CT	Hole cleaning stage.
8	Bottoms Up (Circulate)	TSW	0.7 - 1		300 (minimum)	0	60	Stationary CT	Hole Cleaning stage. 1 Hour CBU
Once completed CBU and clear return is established, flag#2 at surface.									
9	POOH	TSW	0.7 - 1		300 (minimum)	10 - 30		To Surface	Monitor return on surface

36. Once at target depth, flag CT string on surface.
37. Remaining stationary and proceed to pump 20 bbls of gel followed with CBU for 1 hours (as per CIRCA analysis).
38. Once complete CBU, start to wiper trip up and POOH to surface
39. Wiper trip speed suggested base on CIRCA analysis **10 ft/min**, until depth 1,100 m. After that continue to POOH normal speed **30-50 ft/min/ 9-10m/min**.
40. Once at surface, handover to slickline for TCC.

Prepared By: Muhammad hafiz	Reviewed By: Kung Yee Han	Date: 15/4/2024	Rev. Rev0	Controlled Document DB-CT-MHS-24006	Pg. 29
--------------------------------	------------------------------	--------------------	--------------	--	-----------

DIMENSION BID

DIMENSION BID COILED TUBING SERVICES



DULANG C-15L

SCO

APPENDIX I – BHA SCHEMATIC

BHA#1: 1-11/16 SpinCAT Nozzle

DIMENSION BID

BHA DIAGRAM #1 - 1.69" SPINCAT NOZZLE

Client	Petronas Carigali
Field	Dulang C
Job Type	
Job No.	Run#1

Well	C-15L
Min Restriction	
BHP	
BHT	

BHA DRAWING	DESCRIPTION	CONNECTION		ID	OD	TOOL LENGTH	CUMULATIVE LENGTH
		UPHOLE	DOWNHOLE				
	Internal Dimple Connector	1.5" CT	1.0" AMMT PIN		1.690	0.3	0.3
	MHA Disconnect drop ball 5/8"	1.0" AMMT BOX	1.0" AMMT PIN		1.690	2.3	2.6
	Circulating drop ball 1/2"						
	Burst Disc 5000 psi						
	3 ft Straight Bar	1.0" AMMT BOX	1.0" AMMT PIN		1.690	3.0	5.6
	Downhole Filter	1.0" AMMT BOX	1.0" AMMT PIN		1.690	3.2	8.80
SpinCat	1.0" AMMT BOX			1.690	1.0	9.8	
BHA LENGTH						9.80	
MAXIMUM OD						1.69	
MINIMUM ID							

APPENDIX II – CT STACK UP

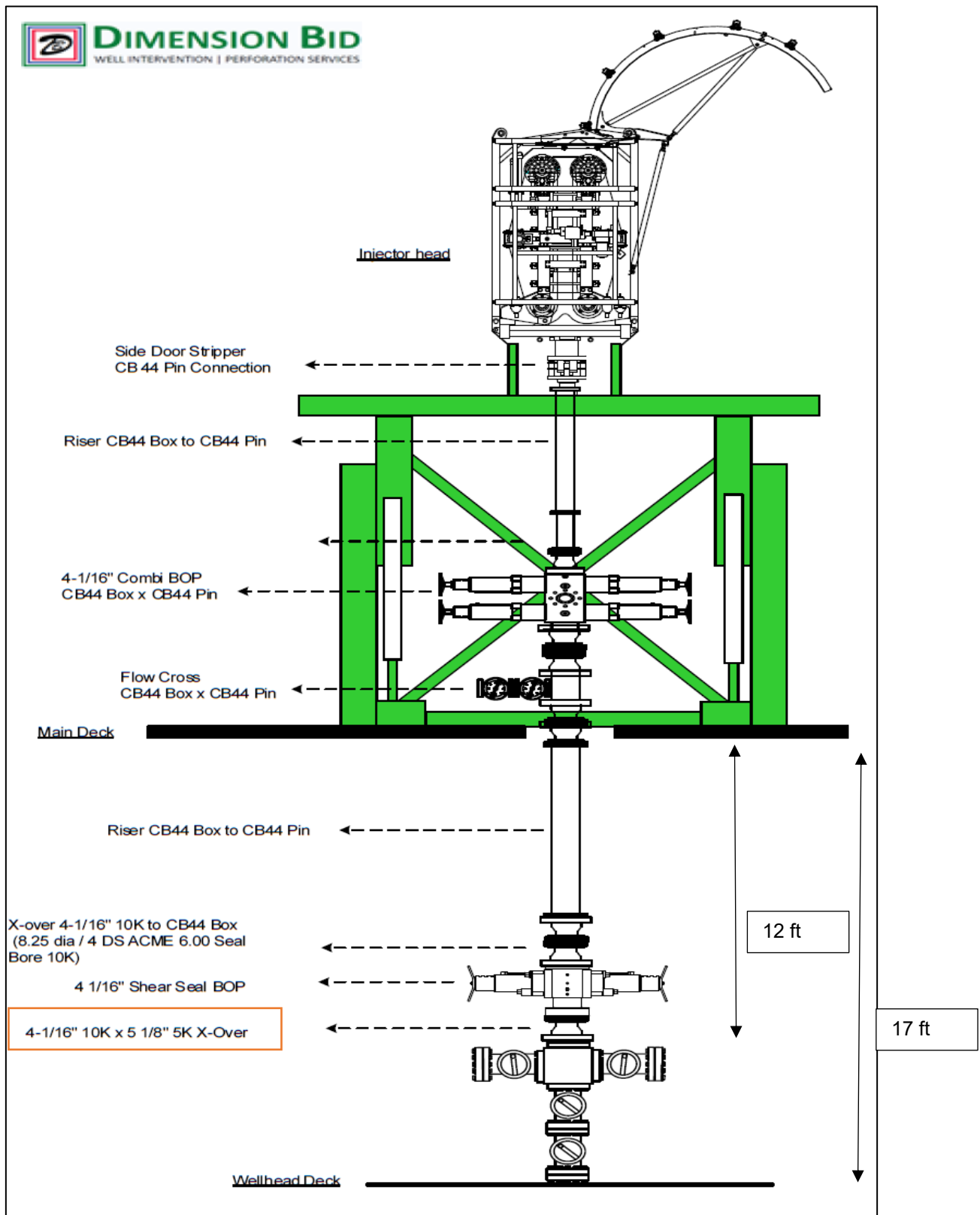

APPENDIX III – ORPHEUS SIMULATIONS

TUBING FORCE ANALYSIS

Graph(1)

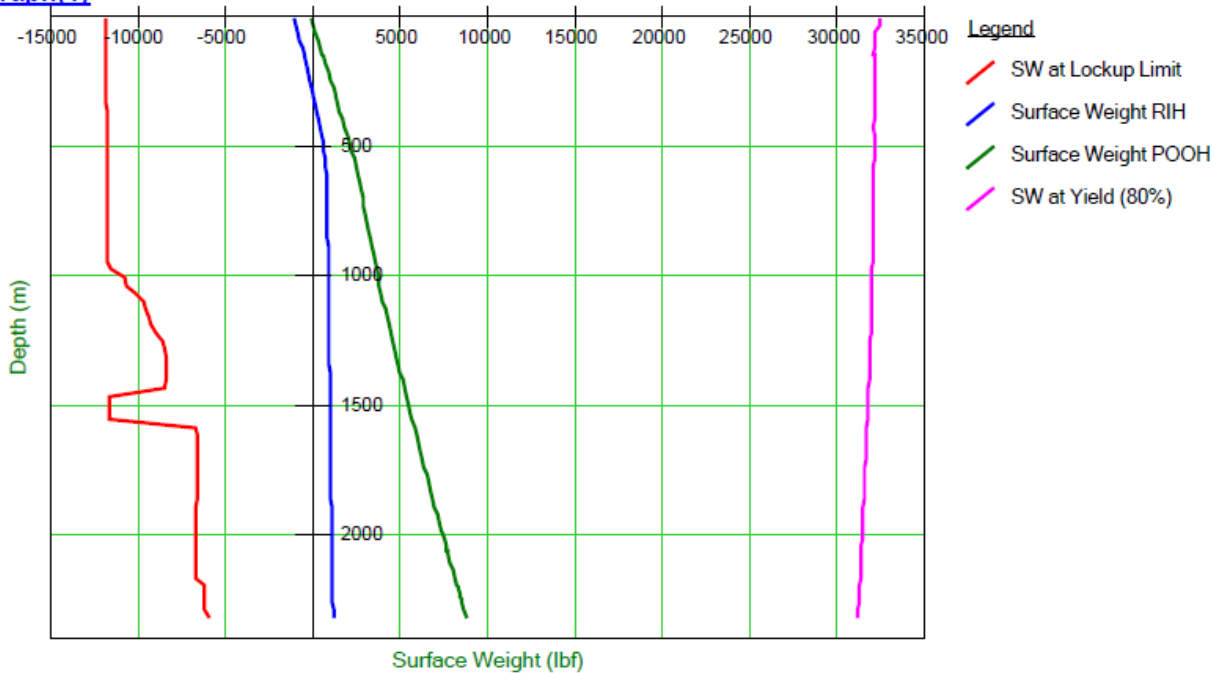

RIH & POOH WEIGHT

RIH and POOH
between 0.0 m and 2323.0 m

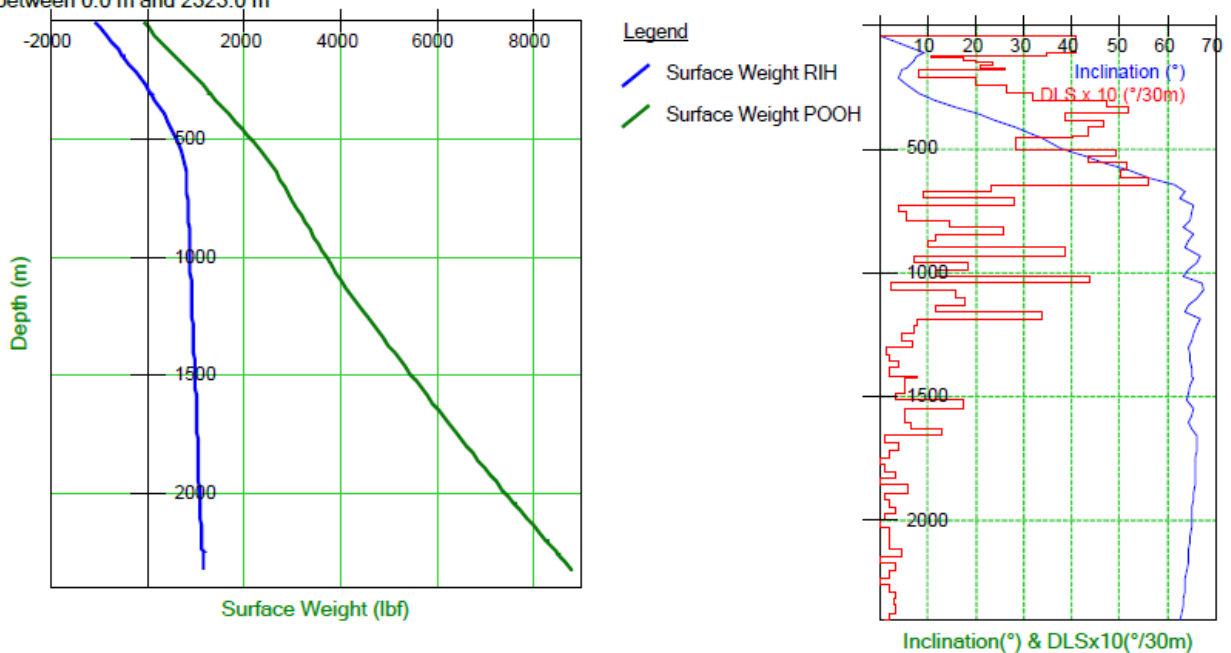

MAXIMUM STRING SET DOWN LIMIT

MD3 ■ The available set-down force at 2323.0 m is -2760 lbf at the end of the string.
 The weight indicator reading will be -5930 lbf on surface.
 The minimum available set-down force is -2654 lbf at 1677.5 m.

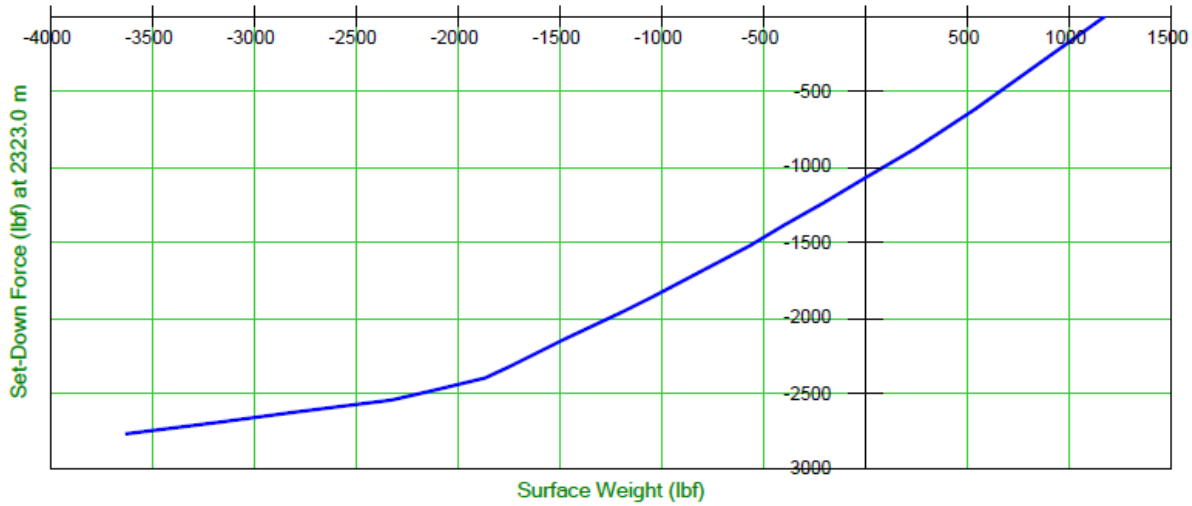

MAXIMUM STRING PICK UP LIMIT

Calculations at 2323.0 m

MD1 ■ The available pick-up at 2323.0 m based on 80% of yield strength is 13633 lbf.
 The weight indicator reading will then be 31172 lbf.

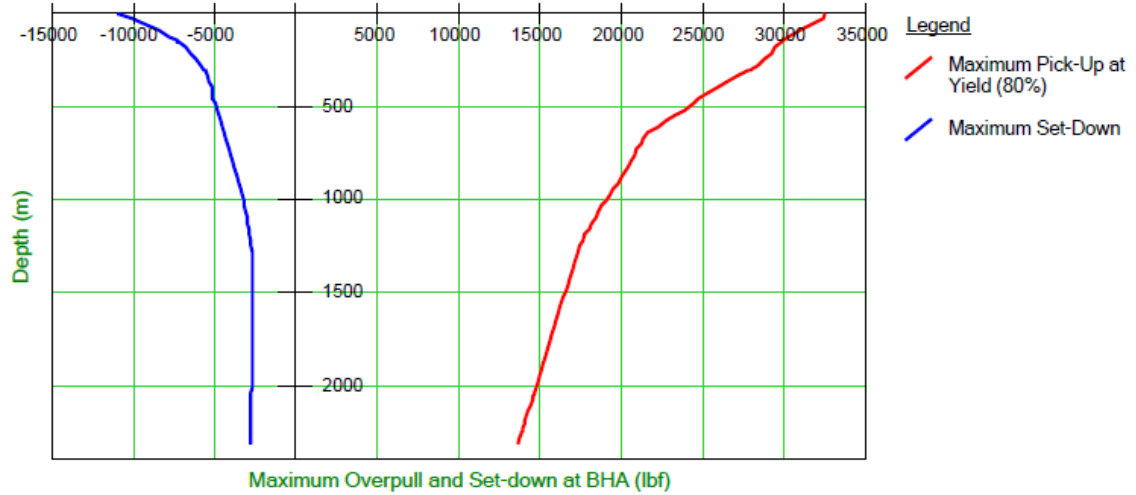

STRING LIMIT

CT Limits

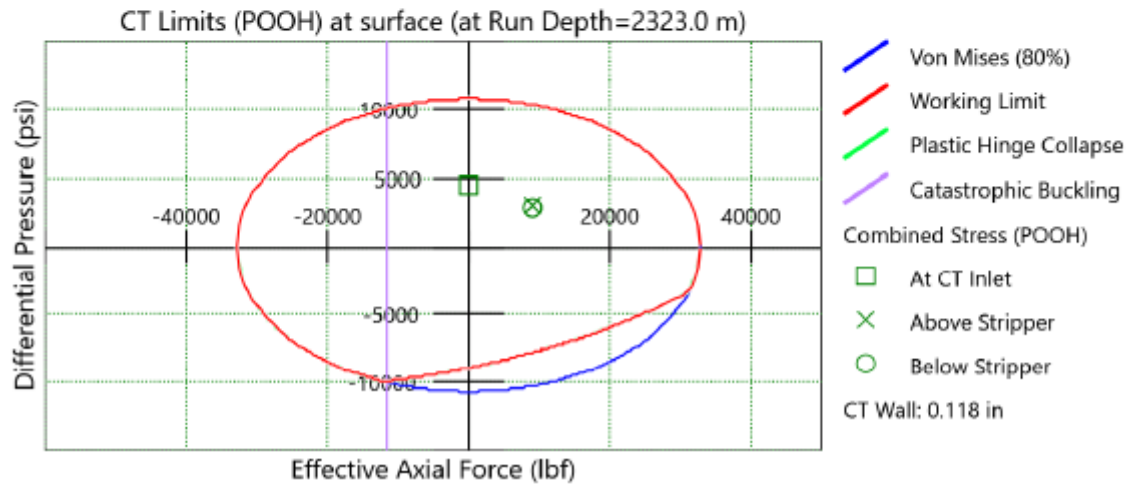
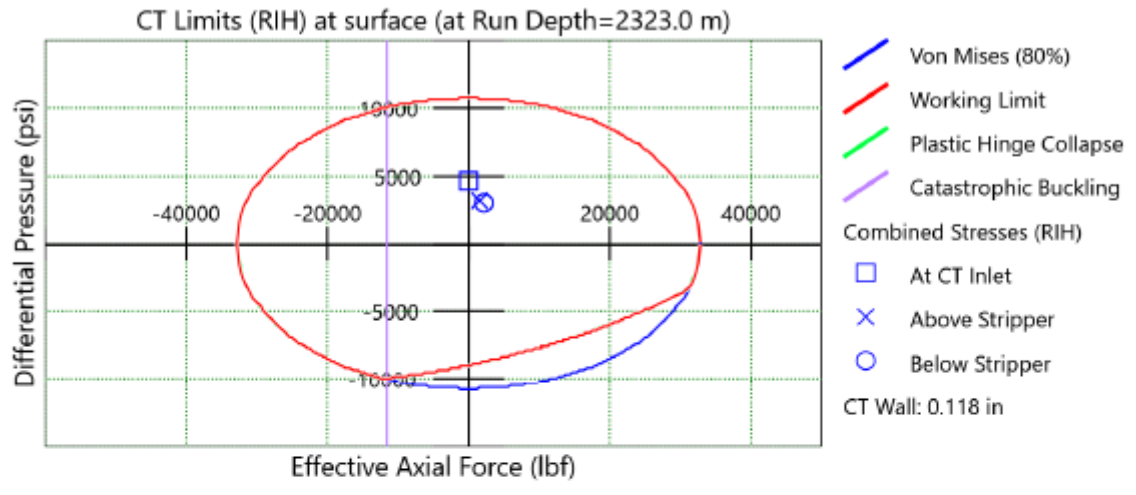

SENSITIVY ANALYSIS TFA

Idle Rate (0.3 bpm)

RIH and POOH

between 0.0 m and 2323.0 m

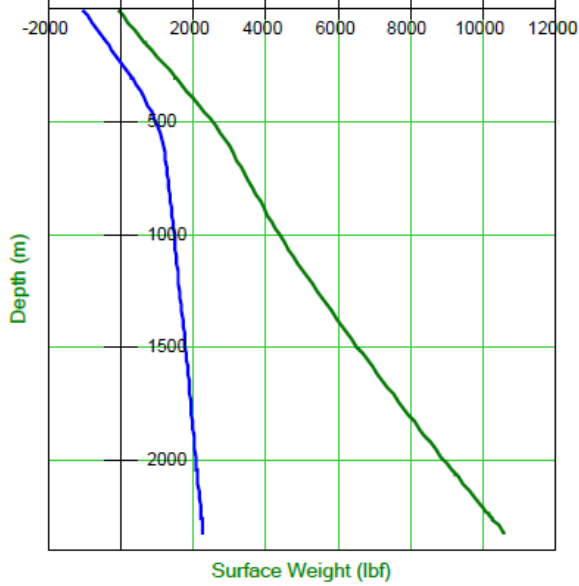

Legend

- Surface Weight RIH
- Surface Weight POOH

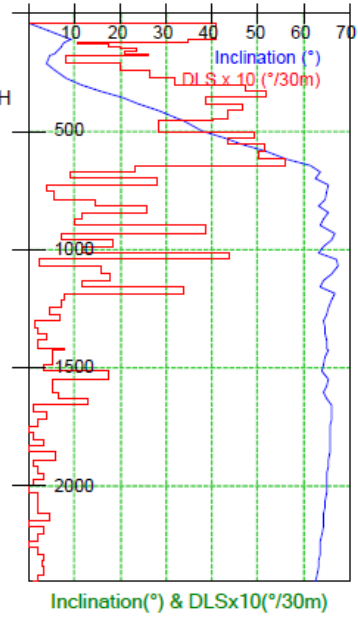

High Rate (1 bpm)

RIH and POOH

between 0.0 m and 2323.0 m

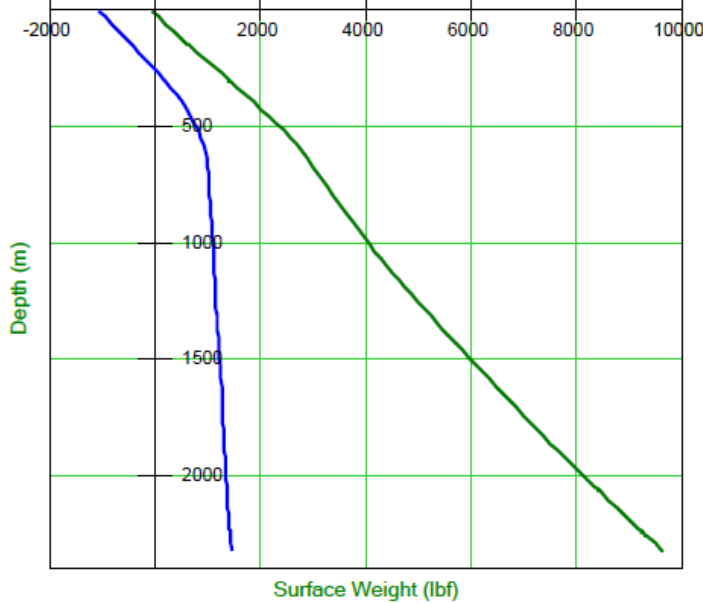

Legend

- Surface Weight RIH
- Surface Weight POOH

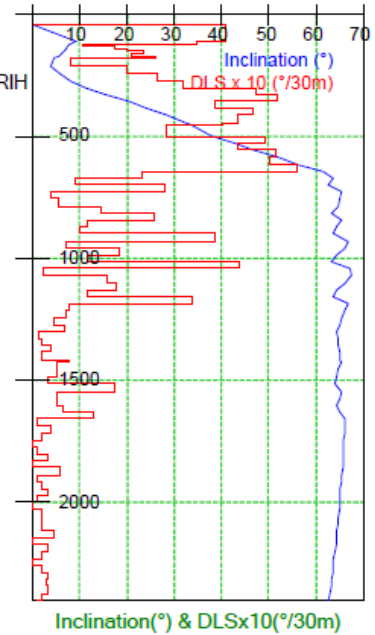

Nitrified (1 bpm 300 scfm)

DIMENSION BID

DIMENSION BID
COILED TUBING SERVICES



DULANG C-15L

SCO

RIH and POOH
between 0.0 m and 2323.0 m

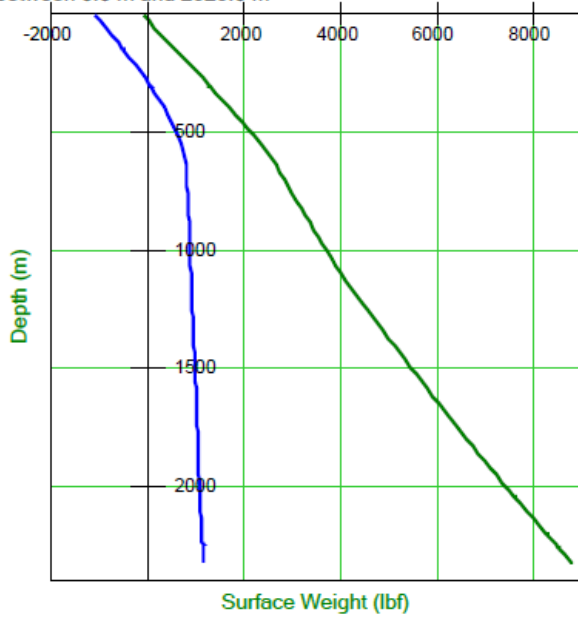

Legend

- Surface Weight RIH
- Surface Weight POOH

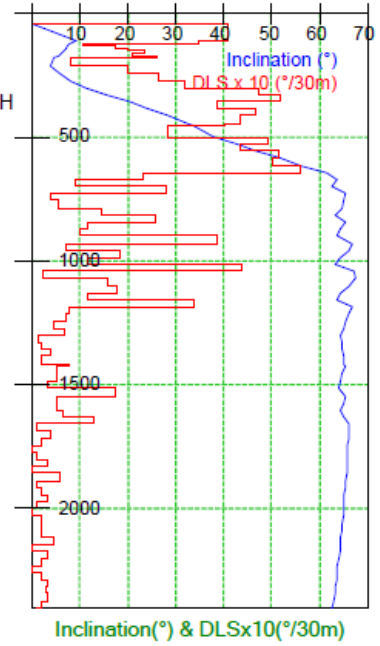

DIMENSION BID	DIMENSION BID COILED TUBING SERVICES		
	DULANG C-15L	SCO	

APPENDIX IV – EMERGENCY PROCEDURE

EMERGENCY BOP OPERATIONS

In the event of an emergency arising and the well having to be secured, the following steps should be taken:

1. Stop CT movement, close the Slip and Pipe rams and slack off string weight to ensure slips are holding. If time permits, review all options with the client representative. (Ensure that rams with guides are activated first to avoid damaging the CT).

Note: The decision to proceed past the above step should normally be made after consultation with the client representative unless there is an immediate and serious danger to personnel and/or equipment and the client representative is not immediately available to be involved in the decision.

2. Stop pumping.
3. Close the upper Shear Seal rams to cut the CT.
4. Set up to circulate well to kill fluid through the CT remaining in the well.
5. Make arrangements necessary to fish the CT from the BOP.

Note: When actuating any ram in the BOP system, the corresponding manual lock should be closed behind it to prevent accidental release in the event of total loss of hydraulic power. The force required to close the rams manually against pressure cannot be supplied by turning in the locks. Use of a pipe wrench, cheater bars or snipes will damage the internal workings of the ram actuators. Some form of hydraulic power is required to operate the actuators. This pressure can be supplied via a hand pump or a hydraulic pump from any other piece of equipment on location, including a fluid pumper.

Actuating the BOP System Hydraulic Controls

1. Remove locks on control panel
2. Move the control lever to the desired position.
3. Push the BOP activate button supplying pressure to the circuit.
4. Observe the pressure drop in the hydraulic circuit and subsequent pressuring back up to system pressure as ram opens or closes completely.
5. Observe the ram indicator pins to verify the operation of the ram.
6. Close in the manual locks if required. (Flag system to indicate position of rams.)

The connections below the CT BOP must be all flanged. Should one of these connections start leaking, the following steps should be taken in consultation with the client representative:

1. Call local alert and ensure all personnel are removed from the wellhead area.
2. Notify the client representative of the problem and determine the best method to make the area safe.
3. If the leak is minor, it may be possible to continue to pull the CT to surface. Assess the scenario and consider all the risks associated then proceed to pull the CT to surface. Once at surface, close available valves below the leak point.
4. If the leak is more severe, initiate a well kill through the well kill line and continue to pull the CT to surface.
5. If the leak is catastrophic, run the CT to HUD; pick up sufficient so that after the CT is cut at surface by CT BOP shear; the top of the CT falls below the X-mass Tree. Once the end of the CT is off bottom, proceed to cut the cut the CT with the shear RAM then close the available valves below the leak point. A well kill operation can be started through the kill line if requested by the client representative.

Prepared By: Muhammad hafiz	Reviewed By: Kung Yee Han	Date: 15/4/2024	Rev. Rev0	Controlled Document DB-CT-MHS-24006	Pg. 37
--------------------------------	------------------------------	--------------------	--------------	--	-----------

DIMENSION BID	DIMENSION BID COILED TUBING SERVICES		
	DULANG C-15L	SCO	

LEAK IN CT AT SURFACE

In the event of a leak in the CT occurring at surface, the following steps should be taken:

1. Call local alert and ensure all personnel are removed from the operational area. In particular make sure all personnel remain clear of the area between the Injector Head and the CT reel.
2. If the leak is small or a pinhole leak, POOH and position the leak on the lower part of the CT reel as soon as possible. Be careful when area of leak is bent onto the reel as failure may occur. Make arrangements to have a water hose present to wash away any fluid from the reel which may be hazardous. Make arrangements to start pumping water through the CT reel. Depressurize reel as much as conditions allow without exceeding collapse limitations of CT.
3. Notify client representative of problem and determine best method to make area safe. If leak is minor and water can be displaced to leak, continue to POOH and change reel.
4. If leak is considered to be too serious to displace to water and POOH, or serious and uncontrolled leakage of hydrocarbon or hazardous materials prevents this, (i.e. check valves not holding, lost BHA, parted CT) set the CT slips and pipe rams. Activate the upper Shear Seal rams on either the triple or quad BOP and manually lock in place.
5. Depressurize the CT reel and flush through the reel. If hydrocarbons are present in the reel, displace the reel with water and empty the contents to specified safe disposal area.

LEAK IN CT BELOW SURFACE

If a leak occurs in the CT below the Stuffing Box during down hole operations (usually indicated by a drop in pump pressure or loss of string weight), suspend CT operations and alert the client representative.

Note: If indications are that the BHA has been lost in hole then revert to section 0.

1. Once the client representative has been alerted, clear all personnel from the immediate area of the CT around the Injector Head and between the Injector Head and the CT reel.
2. Displace the CT to water and commence to POOH at not more than 20 ft per minute (5 meters/min). Ensure at all times that all personnel are clear of the immediate area as the possibility exists to pull the CT out of the Stuffing Box. Continue pumping water at a slow rate through the CT.
3. When the leak in the CT appears above the Stuffing Box, stop the injector and hold the leaking section of CT between the chains and the Stuffing Box.
4. Inspect leak. If leak is minor continue to POOH.
5. If leak is major, or CT is actually severed or well bore fluids are escaping through the CT, continue as per Section 09.2.

Prepared By: Muhammad hafiz	Reviewed By: Kung Yee Han	Date: 15/4/2024	Rev. Rev0	Controlled Document DB-CT-MHS-24006	Pg. 38
--------------------------------	------------------------------	--------------------	--------------	--	-----------

DIMENSION BID	DIMENSION BID COILED TUBING SERVICES		
	DULANG C-15L	SCO	

LEAK IN SURFACE PRESSURE CONTROL EQUIPMENT

Stuffing Box

1. **Stop** CT movement and close both sets of pipe rams to seal CT annulus. Set manual lock.
2. On semi-submersible operations this will be a set of pipe rams and pipe/slip rams.
3. Notify Client representative.
4. Ensure the injector is in neutral and that the brake is engaged.
5. Bleed off pressure above pipe rams
6. Set reel brake. On Semi-Submersible jobs the CT should be clamped at the level wind and CT run out of hole until enough slack between the injector and reel is obtained to cope with the heave from the rig, prior to setting reel brake.
7. Bleed off closing pressure on Stuffing Box. Open side doors and apply pressure to retract piston. Replace packer elements and then re-apply pressure to Stuffing Box. Close side doors.

Note: 3" side door Stuffing Boxes first bleed off closing pressure. Remove hoses from pack and retract piston and connect to open and close on side door. Open door and replace packer element. Close door, bleed off pressure and connect to pack and retract piston.

8. Slowly open both equalizing valve on pipe rams and check that stripper is holding pressure.
9. If stripper is holding pressure, undo manual locks and open pipe rams or pipe slip rams. When using pipe/slip rams the depth that they were set on the CT must be recorded. Release reel brake and continue operations.

Surface Leaks Other Than Stuffing Box

1. If leak is minor and a relatively short length of CT is in the hole and the Shear Seal safety head is **below the leak**:
2. Call local alert and notify the client representative.
3. Clear all non-essential personnel away from the area
4. Continue POOH and monitor situation closely
5. Hook up kill line to BOP and pump water slowly down annulus.

Note: Avoid collapse situation

1. Close swab valve and Shear Seal once CT is in riser and repair leak
2. Perform reinstatement test on surface equipment after leak has been repaired
3. If CT is in the well to a considerable depth and leak is considered serious:
4. Call local alert and notify Client representative.
5. Ensure all non-essential personnel are removed from the area.
6. Ensure that CT is sufficiently off bottom so that when the Shear Seal safety head is activated the pipe will drop below the Xmas tree manual master valve. If the CT is stuck down hole, pull to 80% of operating limit before activating Shear Seal BOP, thus allowing the CT to drop below the Xmas tree manual master valve. If the CT is attached to a fish, packer etc pull to 80% of operating limit (if possible) or maximum weight possible before activating Shear Seal BOP, thus allowing the CT to drop below the Xmas tree manual master valve. **If at all possible**, the decision to cut the CT and activate the system will be taken by the Client representative in charge of the operation. This may not always be possible. If the situation is extremely dangerous and requires a fast decision, the Supervisor in charge will take this decision.

Prepared By: Muhammad hafiz	Reviewed By: Kung Yee Han	Date: 15/4/2024	Rev. Rev0	Controlled Document DB-CT-MHS-24006	Pg. 39
--------------------------------	------------------------------	--------------------	--------------	--	-----------

7. Close the Shear Seal rams in the safety head to cut the pipe and allow it to drop. (If the safety head has separate shear and blind rams, close the shear rams to cut the pipe, pull up the CT and close the blind rams).
8. Close the swab valve on the Xmas tree.
9. Close the master valve on the Xmas tree
10. Repair leak and pressure test riser.
11. Plan for fishing operations.

Rotating Joint Leak

Eliminate the potential for reel movement by securing the reel with turnbuckles and set reel brake. On Semi-Submersible jobs the CT should be clamped at the level wind and CT run out of hole until enough slack between the injector and reel is obtained to cope with the heave from the rig. Close the reel isolation valve inside the reel and repair or replace the rotating joint as required. Re-test and resume operations.

CT RUNS AWAY INTO WELL

If the inside chain tension system on the Injector Head should fail for any reason, and CT is pulled into the well under its own weight with no control, the procedure should be as per the following:

1. Call a local alert.
2. Attempt to speed the injector up to match the speed of the descending CT.
3. Increase inside chain tension to increase friction on CT.
4. Increase stripper pressure to exert more friction on CT.
5. If these actions fail to make any difference, reduce injector hydraulic pressure to zero.
6. In the event that there is insufficient CT on the reel to reach bottom close CT slips. This action may damage or break the CT. This is the preferred option to using the pipe rams as these will become damaged and a primary well control system will be lost.
7. If the CT is not too far off bottom it may be practical to let it fall to bottom then investigate the causes and repair. This can only be done if there is sufficient CT on the reel to reach bottom.

Note: CT may helix when hitting bottom making it difficult to pull into tail pipe.

8. Once CT has been controlled, examine Injector Head for damage including chains and POOH.
9. The CT run away may be caused by the injector becoming overloaded with the weight of the CT and fluid in the CT. This situation should not occur if proper pre job planning is done. Correct selection of Injector Head or ensuring CT is full of Nitrogen would prevent this situation from occurring.
10. If a runaway situation occurs, reduce the injector hydraulic pressure to zero. This may cause the safety brake in the motors to actuate and counter balance valves to close, stopping the injector.
11. Under certain circumstances if the runaway CT is at a speed above the critical speed, the back pressure created by the circulating hydraulic fluid may prevent the injector motor brakes from actuating. If this situation occurs, select the pull mode for the injector and increase system hydraulic pressure until the CT comes to a standstill.

DIMENSION BID	DIMENSION BID COILED TUBING SERVICES		
	DULANG C-15L	SCO	

CT IS PULLED OUT OF STUFFING BOX

This situation is most likely to occur when the CT is being pulled into the riser section. If the BHA is lost including the End Connector there will be no external upset to prevent the CT from passing through the Stuffing Box. If this situation occurs, stop injector before CT passes through the chains and shut in Shear Seal rams on upper BOP's.

If it is thought that the BHA may be lost while down hole, stop the CT at 300ft from surface. Slowly close in the swab valve counting the number of turns. If the CT is still deemed to be across the wellhead, POOH the CT no more than the distance between the top of the wellhead and the top of the CT BOP's. Repeat this step until the swab valve can be fully shut. Once the swab valve is shut, bleed off the pressure in riser.

CT COLLAPSED AT SURFACE

Collapsed CT at surface will be obvious by escape of well bore fluids from the Stuffing Box, as the strippers will no longer seal round the deformed pipe. In addition to this the collapsed pipe will not allow the Injector Head to grip the CT due to its change in shape. Usually collapsed CT will not pull through the bottom brass bushings on the Stuffing Box.

1. If POOH, immediately run CT back in well a sufficient distance to make sure round pipe is in contact with the Stuffing Box.
2. Call alert and notify client representative.
3. Ensure that all non-essential personnel are cleared from the immediate area.
4. Immediately reduce well head pressure by all safe means possible; either flow well through choke at a higher rate or stop annular fluid injection if reverse circulating.
5. Increase CT internal pressure by circulating.
6. Once pressure conditions inside and outside the CT have been optimized, a decision can be taken on how to proceed. If it is not possible to position un-collapsed pipe across the stripper rubbers, i.e., well contents are escaping from stripper rubbers:
7. Call alert and notify client representative.
8. Close pipe rams in an effort to reduce flow of fluid/gas around CT.

Note: If it is not possible to control the well, the slips will have to be set, and the CT cut using the Shear Seal rams.

9. Arrange for clamps to be fitted to CT above Injector Head.
10. Remove all non-essential personnel from immediate area
11. Under authority from client representative, kill well.
12. Release pressure from Stuffing Box and remove bushings.
13. Open pipe rams.
14. Attempt to pull CT from the well using the Injector Head.
15. Cut CT at the gooseneck and use the rig or a crane to pull the CT through the injector. Re-clamp the CT above the Injector Head and cut off in thirty-foot sections (or as appropriate to the crane or rig)
16. Continue pulling and cutting CT until the CT pulled to surface can be pulled by the Injector Head.
17. Once CT in good condition (i.e. not collapsed) is at surface, set CT slips and pipe rams and make up roll-on connector to CT on reel.
18. Continue POOH.

If the leak is too serious and cannot be controlled and well fluids are escaping, continue as per Section 9.2.

CT BREAKS AT SURFACE

If CT breaks at surface into two separate sections:

Prepared By: Muhammad hafiz	Reviewed By: Kung Yee Han	Date: 15/4/2024	Rev. Rev0	Controlled Document DB-CT-MHS-24006	Pg. 41
--------------------------------	------------------------------	--------------------	--------------	--	-----------

1. Stop the injector and set the slips.
2. Stop pumping operations.
3. Call alert and notify client representative. Ensure all non-essential personnel are cleared from the area and that the area is secure.
4. Secure CT reel.
5. If the reel capacity is insufficient to hold all of the CT remaining in the well due to uneven spooling resulting from the CT failure, it may be necessary to obtain another reel with sufficient capacity to hold the CT remaining in the well.
6. After consulting with client representative, remove damaged section of CT and insert in line roll-on connector and continue to POOH.
7. If this course of action is considered inappropriate or dangerous due to well conditions or condition of CT still in the well, continue as per Section 0.

BUCKLED TUBING

Should the CT hit an obstruction down hole while RIH with the thrust pressure set too high or running speed too fast, the CT will buckle in a 'Z' shape (plastically hinged).

CT being run inside CT and through small ID BOP's/lubricators will normally buckle between the Stuffing Box and the chains.

CT being run through casing or open hole will normally break below the BOP, usually somewhere around the largest ID.

- The CT will generally buckle several times.
- This type of failure is a little more difficult to detect.

If the CT is being run into casing and a large amount of weight is lost suddenly, there is a very good possibility that the CT is buckled somewhere down hole. Indications of this could be:

- An increase in pump pressure as fluid or gas is now being pushed through an additional restriction created by a hinge.
- A decrease in pump pressure as the CT may have broken removing a restriction such as a BHA.
- A loss of string weight due to the CT breaking and falling off.
- An increase in string weight while pulling out of the hole as the buckled portion of CT creates additional drag or needs to be straightened to get through a restricted ID.

In the event CT buckling is suspected, the CT movement should be stopped and the pump pressure kept within operating limits allowing the situation to be analyzed and determine the correct action to be taken for existing conditions.

If there is an increase in pump pressure or an increase in string weight:

1. Stop the pumps and pick up slowly.
2. POOH slowly (10 to 20 feet per minute) watching the weight indicator carefully.
3. If the CT is buckled close to surface, the buckled CT will pull into the bottom of the Stuffing Box and stop.
4. Close and lock the slip and pipe rams.
5. If the ram indicators show that the rams are not completely closed, there may be more than one piece of CT inside the BOP. In this event, open the rams and try to put undamaged CT across the pipe and slip rams.
6. Make arrangements to kill the well and retrieve the remaining CT from the well.

7. If the buckled CT is down hole and cannot be pulled free, consult the client representative as he may want the CT left at TD prior to being hung off in the slip and CT rams.
8. Arrangements should be made to run CT cutter on wireline to retrieve the CT above stuck point.

If there is a decrease in pump pressure or a loss of string weight:

1. It must be assumed that the CT has parted somewhere down hole.
2. Calculate from the remaining string weight approximately how much CT is left in the well.
3. Stop the pumps and POOH slowly.
4. Should the CT come out of the Stuffing Box, the blind rams should also be closed in.

If the CT is buckled above the Stuffing Box, the following steps should be taken:

1. Stop the injector as quickly as possible.
2. Close the slip and pipe rams and manually lock them.
3. If the down hole check valves are holding, bleed the pressure in the CT down to zero and monitor for 15 minutes for pressure build up.
4. Consider at this stage whether to kill the well.
5. Use a hacksaw to start the cut until you are sure there is no trapped pressure in the CT.
6. Cut the CT
7. Remove as much of the buckled CT as possible leaving any undamaged CT showing above the Stuffing Box intact so that it may be rejoined later.
8. Bleed the pressure from above the CT rams and undo the connection below the injector.
9. Slowly raise the injector until it is clear of the damaged CT.
10. Cut away any damaged CT, dress the CT and install an inline connector.
11. Run some fresh CT down through the injector until it is just out of the Stuffing Box.
12. Lower the injector until immediately over the pipe sticking out of the BOP.
13. Attach the pipe to the inline connection attached to the pipe sticking up out of BOP.
14. Pump off the inside chain tension and rotate the chains slowly in the OOH direction, while lowering the injector until the connection below the injector can be fastened.
15. Pump up the inside chain tension and pull weight equal to the weight of the CT suspended below the slips plus 2,000 lbf for friction or CERBERUS prediction, whichever is greatest.
16. Equalize the pressure across the CT rams.
17. Unlock the pipe and slip rams.
18. Open the slip and pipe rams and POOH.
19. If the down hole check valves do not hold then the CT will have to be cut.

CT STUCK IN HOLE PROCEDURES

There are various scenarios by which CT can be deemed as a stuck in hole situation. The following procedures are to be used as generic guidelines prior to the compilation of a signed off chemical cutting program applicable to the current situation.

In the event of being stuck in hole, several factors would have to be taken into consideration, the first of which would be whether the CT is stuck in hole on a platform, or a semi-submersible, as the procedures to be followed may vary greatly between the two options.

Other factors to be considered are:

DIMENSION BID	DIMENSION BID COILED TUBING SERVICES		
	DULANG C-15L	SCO	

- Type of well, i.e., flowing oil or gas well, water injector etc.
- The type of BHA being used, i.e., perforating guns, milling assembly, plug etc.
- The type of operation being carried out when the CT became stuck.

In all of the above cases, the CT would be defined as being “stuck” when the pipe cannot be retrieved from the well bore without the pipe exceeding its 80% minimum yield rating, or without exceeding 80% stress of the weak link release rating. The lower of these two factors should always be used when attempting large pulls.

Regardless of the specifics involved, the following procedures should be adopted:

1. Inform the client representative of the situation.
2. Inform the Onshore Engineer.
3. From the information available, and taking into account the well conditions, try to determine the reason for the pipe/BHA being stuck.
4. Attempt to pull free by applying a steady pull to a maximum of 80% of the CT yield. If in doubt as to what this figure is, consult Engineering Department before proceeding.
5. When applying the maximum pull, hold the maximum value for a minimum of 10 minutes and observe the trend (if any) on the weight indicator and chart. Measure the amount of pipe extension that is required when this pull is applied. The figure can be used to determine where the CT is stuck. As a rule of thumb, the depth that the pipe is held at will be the extension of the CT (in feet) when pulled to 80% of yield divided by 0.002. This can be determined using CERBERUS.

The following are options that may be appropriate depending on the particular circumstances:

1. If possible, flow the well, or increase well flow in an effort to remove debris in the well bore that may be holding the CT/BHA. Maintain maximum circulation through the CT at the same time. This is particularly relevant if well cleanout or drilling operations have been performed.
2. Circulate acid across the BHA in an attempt to remove any acid soluble material that may be holding the CT.
3. Pump fluid down the backside of the CT to the formation in an attempt to dislodge debris from around the BHA. Potential CT collapse must be considered if engineering this scenario.
4. Displace CT contents to a lighter fluid (base oil) or gas (Nitrogen) to increase buoyancy and allow greater end force to be applied at BHA.
5. Underbalance the well in the case of differentially stuck CT.
6. Cool the well if the CT is helically stuck in corkscrewed Production Tubing.
7. Pump down the CT / completion annulus to try and move the source of hold-up.
8. Displace slugs of Nitrogen with water to create a surge effect at the BHA.
9. Pump friction reducer, IM Lube in seawater at 2-3% by volume, down the CT and into the well. Ideally, one well volume will be pumped.
10. After consultation with the client representative and the on-call Engineer, activate the emergency disconnect mechanism in the BHA to allow the CT to be released. The release mechanism should only be implemented after all avenues have been explored.
11. When attempting maximum pull, do not work the CT violently across the gooseneck by frequent intervals.
12. The number of cycles across the gooseneck must be logged, and if in doubt of the CT fatigue condition, the Engineer must be consulted and the cycles entered into the CERBERUS FATIGUE program, to determine the number of cycles left available.

After consultation with the client representative, kill the well and commence preparations for External/Internal cutting operations.

Prepared By: Muhammad hafiz	Reviewed By: Kung Yee Han	Date: 15/4/2024	Rev. Rev0	Controlled Document DB-CT-MHS-24006	Pg. 44
--------------------------------	------------------------------	--------------------	--------------	--	-----------

STUCK CT COIL RECOVERY PROCESS

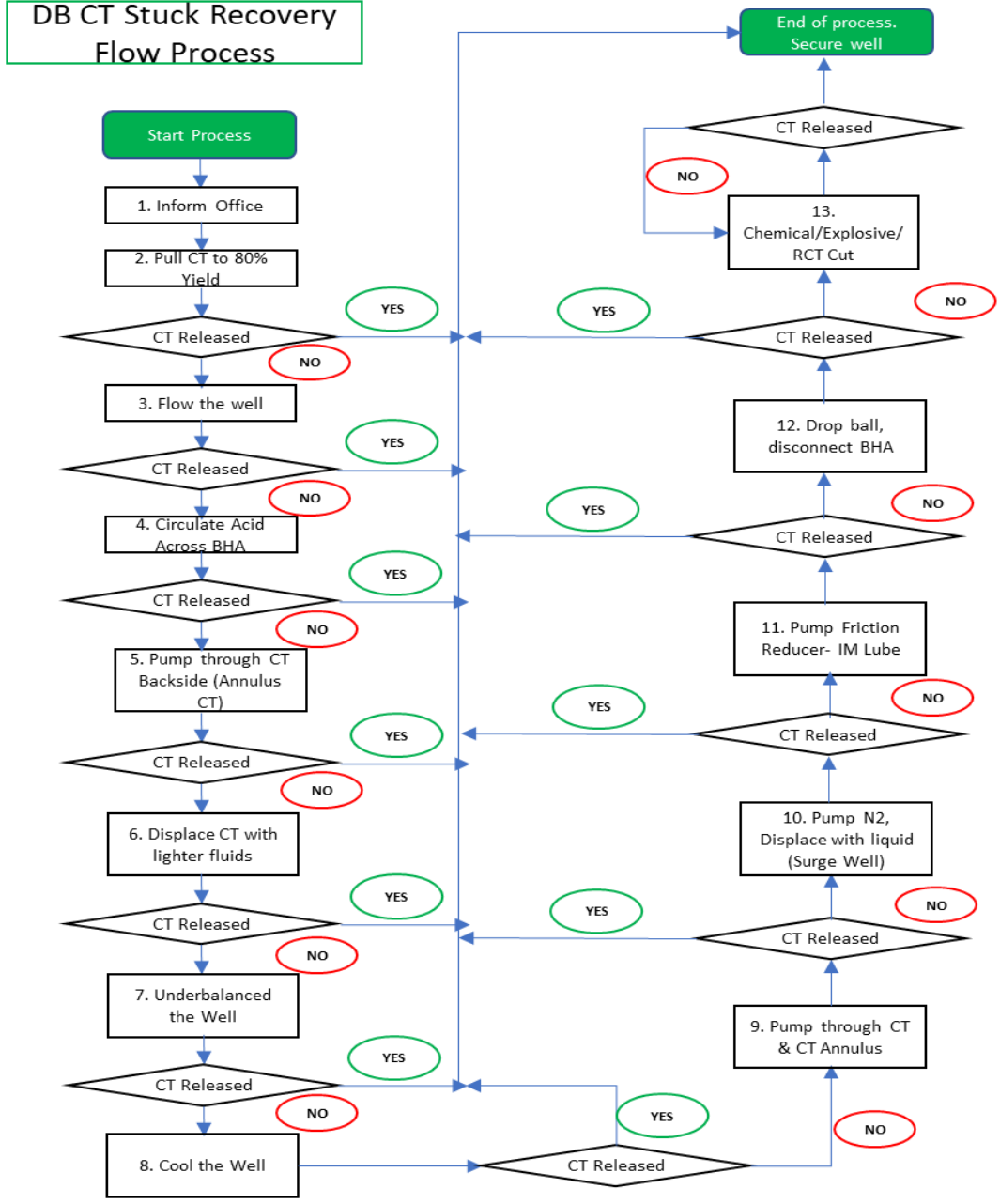

Precautionary Steps to avoid Stuck while Cleanout in Dual string Completion:

- 1) To monitor pressure trending all the times during operation and record for any abnormalities. If there is continue pressure increasing trend during cleanout, proceed to pick up coil to the previous pull test depth and perform flow rate test.
- 2) In the event of coil entangle on the Long string, proceed to pick up coil and simulate pumping lost prime scenario to create vibration and tip of coil wobble to release from entanglement.

APPENDIX V – DOWNHOLE TOOL SPECS

SpinCAT

<p>SC-168: 9.8 in – 25 cm</p> <p>Outside Diameter: 1.68 in 4.3 cm</p>	<p>STONEAGE SPINCAT™ SC-168 <small>†SHARE</small></p> <p>The StoneAge SpinCat™ SC-168 can be used at operating pressures of 1000 to 5000 psi and flow rates of .7 to 1.33 bpm (30 to 56 gpm). It has a 1" AMMT inlet thread.</p>																																										
<table border="1" style="width: 100%; border-collapse: collapse;"> <tr> <td>Tool Family</td> <td colspan="2">StoneAge SpinCat™</td> </tr> <tr> <td>Tool Model</td> <td colspan="2">SC-168</td> </tr> <tr> <td>Pressure Range</td> <td>1-5k psi</td> <td>70-340 bar</td> </tr> <tr> <td>Flow Range</td> <td>0.7-1.33 bpm</td> <td>30-56 gpm</td> </tr> <tr> <td>Flow Rating</td> <td colspan="2">2.3 Cv</td> </tr> <tr> <td>Rotation Speed</td> <td colspan="2">150-200 rpm</td> </tr> <tr> <td>Inlet Connection</td> <td colspan="2">1" AMMT</td> </tr> <tr> <td>PSI Loss (@ 1 bpm)</td> <td>330 psi</td> <td>23 bar</td> </tr> <tr> <td>Tension (pull)</td> <td>Safe load to 8500 lbs</td> <td>3856 kg</td> </tr> <tr> <td>Compression (set down)</td> <td>Safe load to 12000 lbs</td> <td>5443 kg</td> </tr> <tr> <td>Outside Diameter</td> <td>1.68 in.</td> <td>4.3 cm</td> </tr> <tr> <td>Overall Length</td> <td>9.8 in.</td> <td>25 cm</td> </tr> <tr> <td>Weight</td> <td>4.6 lbs</td> <td>2 kg</td> </tr> <tr> <td>Maximum Temperature</td> <td>390° F</td> <td>200° C</td> </tr> </table>		Tool Family	StoneAge SpinCat™		Tool Model	SC-168		Pressure Range	1-5k psi	70-340 bar	Flow Range	0.7-1.33 bpm	30-56 gpm	Flow Rating	2.3 Cv		Rotation Speed	150-200 rpm		Inlet Connection	1" AMMT		PSI Loss (@ 1 bpm)	330 psi	23 bar	Tension (pull)	Safe load to 8500 lbs	3856 kg	Compression (set down)	Safe load to 12000 lbs	5443 kg	Outside Diameter	1.68 in.	4.3 cm	Overall Length	9.8 in.	25 cm	Weight	4.6 lbs	2 kg	Maximum Temperature	390° F	200° C
Tool Family	StoneAge SpinCat™																																										
Tool Model	SC-168																																										
Pressure Range	1-5k psi	70-340 bar																																									
Flow Range	0.7-1.33 bpm	30-56 gpm																																									
Flow Rating	2.3 Cv																																										
Rotation Speed	150-200 rpm																																										
Inlet Connection	1" AMMT																																										
PSI Loss (@ 1 bpm)	330 psi	23 bar																																									
Tension (pull)	Safe load to 8500 lbs	3856 kg																																									
Compression (set down)	Safe load to 12000 lbs	5443 kg																																									
Outside Diameter	1.68 in.	4.3 cm																																									
Overall Length	9.8 in.	25 cm																																									
Weight	4.6 lbs	2 kg																																									
Maximum Temperature	390° F	200° C																																									
<p>SC-212™ Overall Length: 12.3 in – 31.2 cm</p> <p>Outside Diameter: 2.12 in 5.4 cm</p>	<p>STONEAGE SPINCAT™ SC-212 <small>†SHARE</small></p> <p>The StoneAge SpinCat™ SC-212 can be used at operating pressures of 1000 to 5000 psi and flow rates of 0.8 to 2 bpm (32 to 80 gpm). It has a 1 1/2" AMMT inlet thread.</p>																																										
<table border="1" style="width: 100%; border-collapse: collapse;"> <tr> <td>Tool Family</td> <td colspan="2">StoneAge SpinCat™</td> </tr> <tr> <td>Tool Model</td> <td colspan="2">SC-212</td> </tr> <tr> <td>Pressure Range</td> <td>1-5k psi</td> <td>70-340 bar</td> </tr> <tr> <td>Flow Range</td> <td>0.8-2.0 bpm</td> <td>32-80 gpm</td> </tr> <tr> <td>Flow Rating</td> <td colspan="2">4.6 Cv</td> </tr> <tr> <td>Rotation Speed</td> <td colspan="2">150-200 rpm</td> </tr> <tr> <td>Inlet Connection</td> <td colspan="2">1-1/2" AMMT</td> </tr> <tr> <td>PSI Loss (@ 1 bpm)</td> <td>83 psi</td> <td>6 bar</td> </tr> <tr> <td>Tension (pull)</td> <td>Safe load to 15000 lbs</td> <td>6804 kg</td> </tr> <tr> <td>Compression (set down)</td> <td>Safe load to 21000 lbs</td> <td>9525 kg</td> </tr> <tr> <td>Outside Diameter</td> <td>2.12 in.</td> <td>5.4 cm</td> </tr> <tr> <td>Overall Length</td> <td>12.3 in.</td> <td>31.2 cm</td> </tr> <tr> <td>Weight</td> <td>8.9 lbs</td> <td>4 kg</td> </tr> <tr> <td>Maximum Temperature</td> <td>390° F</td> <td>200° C</td> </tr> </table>		Tool Family	StoneAge SpinCat™		Tool Model	SC-212		Pressure Range	1-5k psi	70-340 bar	Flow Range	0.8-2.0 bpm	32-80 gpm	Flow Rating	4.6 Cv		Rotation Speed	150-200 rpm		Inlet Connection	1-1/2" AMMT		PSI Loss (@ 1 bpm)	83 psi	6 bar	Tension (pull)	Safe load to 15000 lbs	6804 kg	Compression (set down)	Safe load to 21000 lbs	9525 kg	Outside Diameter	2.12 in.	5.4 cm	Overall Length	12.3 in.	31.2 cm	Weight	8.9 lbs	4 kg	Maximum Temperature	390° F	200° C
Tool Family	StoneAge SpinCat™																																										
Tool Model	SC-212																																										
Pressure Range	1-5k psi	70-340 bar																																									
Flow Range	0.8-2.0 bpm	32-80 gpm																																									
Flow Rating	4.6 Cv																																										
Rotation Speed	150-200 rpm																																										
Inlet Connection	1-1/2" AMMT																																										
PSI Loss (@ 1 bpm)	83 psi	6 bar																																									
Tension (pull)	Safe load to 15000 lbs	6804 kg																																									
Compression (set down)	Safe load to 21000 lbs	9525 kg																																									
Outside Diameter	2.12 in.	5.4 cm																																									
Overall Length	12.3 in.	31.2 cm																																									
Weight	8.9 lbs	4 kg																																									
Maximum Temperature	390° F	200° C																																									

APPENDIX VI – CIRCA SIMULATION

Cleanout until top of Plug

Flow Summary

SUMMARY OF FLOW RESULTS

Produced Fluids

Pressure known at:

Production Mode:

Fluid Composition:

Perforations

No Production

Oil Only

Circulated Fluids

Fluid Composition:

Liquid:

Solids:

Gas:

Circulation Point:

HHP Required :

Nitrified Water

0.70 bbl/min

0.00 bbl/min

300.0 scf/min

2257.00 m

41.36 HP

COMPLETION:

Wellhead Pressure.....	327.3 psi g
Hydrostatic pressure loss.....	837.1 psi
Friction pressure loss.....	368.3 psi
Kinetic pressure loss.....	-2.4 psi
Restriction pressure loss.....	0.8 psi
Equivalent Circulation Density[ECD]...	5.60 lb/gal (US)

Perforation Pressure.....	1531.0 psi g
Hydrostatic pressure loss.....	24.5 psi

Bottom Hole Pressure.....	1555.5 psi g
---------------------------	--------------

FROM CIRCULATION POINT TO WELLHEAD:

Liquid transit time.....	16 min
Gas transit time.....	13 min
Annular volume.....	26.7 bbl
Volume below circulation point.....	1.3 bbl
Total liquid volume.....	13.5 bbl
Total gas volume.....	14.4 bbl

WORKSTRING:

Liquid:	0.7000 bbl/min
Gas:	0.43 MMscf/day
Pressure at reel rotating joint.....	2396.5 psi g
Friction pressure loss on reel.....	694.4 psi
Hydrostatic pressure loss on reel.....	0.1 psi
Pressure inside WS at Gooseneck.....	1702.1 psi g
Hydrostatic pressure loss.....	-1129.5 psi
Friction pressure loss.....	1071.5 psi
Equivalent Circulation Density[ECD]...	0.27 lb/gal (US)
BHA total pressure loss	244.7 psi
BHA Hydrostatic loss	-0.1 psi
BHA Friction loss	0.2 psi
Nozzle	244.7 psi
Circulation Point pressure	1515.2 psi g

FROM REEL ROTATING JOINT TO CIRCULATION POINT:

Liquid transit time.....	17 min
Gas transit time.....	15 min
Displacement Volume.....	16.2 bbl
Internal Volume.....	18.8 bbl
Internal liquid volume.....	11.8 bbl
Internal gas volume.....	7.0 bbl
(Surface equivalent).....	4501.3 scf
Length of Workstring on reel.....	1431.30 m

Ctran Summary

SUMMARY OF HOLE CLEANING RESULTS

Initial Condition:	
% of fill interval occupied by solids before cleanout ...	100.0 %
Top of fill	2202.00 m
Deepest Circulation point	2257.01 m
Bottom of fill	2257.01 m
Initial Volume of Solids.....	1.0 bbl
Initial Mass of Solids.....	535.2 lb
Solids type:	Mud Residue/Formation Fines
Fluid Description:	Nitrified Water
Penetration Hole Cleaning Mode:	
Penetration rate.....	5.0 ft/min
Penetration time.....	0.60 hr
Solids volume in the well after penetration	1.0 bbl
Solids mass in the well after penetration	535.2 lb
Circulation Hole Cleaning Mode:	
Hole circulation time	1.00 hr
Solids volume in the well after circulation.....	1.0 bbl
Solids mass in the well after circulation.....	535.2 lb
Wiper Trip Hole Cleaning Mode:	
Wiper Trip Scheme:	User Specified rate, Tornado not
Wiper trip time	6.08 hr
Solids volume in the well after wiper trip	0.0 bbl
Solids mass in the well after wiper trip	0.0 lb
Volume of Fluids Pumped During Penetration, Circulation & Wiper Trip:	
Gas volume	138306.7 scf
Liquid Volume	322.7 bbl
Penetration, Circulation & Wiper Trip time	7.68 hr

Circulation results at point of Maximum Solids Head:

Project: Dulang Charlie	Field-Well: Unknown
<hr/>	
BHA Depth	1712.18 m
Elapsed time	3.9854 hr
Wellhead Pressure	280.0 psi g
Additional Head created by Solids.....	17.3 psi
Maximum % solids circulated up hole was 0.8%.	
This occurred at a measured depth of	1810.21 m
after the transient had run for	0.0 hr

DIMENSION BID

DIMENSION BID COILED TUBING SERVICES



DULANG C-15L

SCO

Flow State

Measured Depth[Flow] <i>m</i>	Temperature	Completion Pressure	Workstring Pressure	Concentric Pressure	Completion Liquid Velocity <i>m</i>	Workstring Liquid Velocity <i>Deg. C</i>	Concentric Liquid Velocity <i>psi g</i>
0.0	40.0	327.3	1702.1	0.0	706	850	0
12.5	40.6	335.7	1707.8	0.0	696	850	0
35.7	41.7	351.3	1718.5	0.0	679	850	0
58.8	42.8	367.0	1729.2	0.0	662	850	0
82.0	43.9	382.7	1739.8	0.0	647	851	0
105.2	45.0	398.5	1750.4	0.0	633	852	0
128.3	46.1	414.3	1760.9	0.0	620	853	0
151.5	47.2	430.3	1771.5	0.0	729	852	0
166.0	47.9	440.5	1778.2	0.0	601	852	0
189.2	49.0	456.7	1788.9	0.0	590	851	0
212.3	50.1	473.0	1799.6	0.0	579	851	0
235.5	51.2	489.4	1810.4	0.0	570	852	0
258.7	52.2	505.8	1821.1	0.0	560	852	0
281.8	53.3	522.4	1831.7	0.0	552	853	0
305.0	54.4	538.9	1842.2	0.0	651	855	0
327.8	55.5	555.3	1852.3	0.0	536	858	0
351.0	56.5	571.6	1862.2	0.0	529	861	0
374.1	57.5	587.8	1871.7	0.0	522	865	0
397.3	58.5	603.8	1880.7	0.0	515	869	0
420.5	59.5	619.5	1889.2	0.0	509	873	0
443.6	60.5	634.9	1897.2	0.0	504	876	0
466.8	61.4	650.0	1904.6	0.0	499	879	0
490.0	62.3	664.9	1911.6	0.0	494	881	0

DIMENSION BID

DIMENSION BID COILED TUBING SERVICES



DULANG C-15L

SCO

Flow State (continued)

Measured Depth[Flow] <i>m</i>	Temperature	Completion Pressure	Workstring Pressure	Concentric Pressure	Completion Liquid Velocity <i>m</i>	Workstring Liquid Velocity <i>Deg. C</i>	Concentric Liquid Velocity <i>psi g</i>
513.1	63.1	679.5	1918.1	0.0	489	883	0
536.3	63.9	693.5	1923.8	0.0	485	885	0
559.5	64.7	707.0	1923.7	0.0	481	756	0
582.6	65.4	719.9	1923.1	0.0	477	745	0
605.8	66.1	732.0	1922.1	0.0	473	733	0
628.9	66.7	743.4	1920.6	0.0	470	721	0
652.1	67.2	753.9	1918.4	0.0	468	708	0
675.3	67.7	764.0	1915.8	0.0	465	701	0
698.4	68.2	774.1	1913.3	0.0	462	701	0
721.6	68.7	784.0	1910.7	0.0	460	699	0
744.8	69.2	793.6	1907.7	0.0	458	695	0
767.9	69.6	803.2	1904.8	0.0	455	696	0
791.1	70.1	813.0	1902.0	0.0	453	698	0
814.3	70.6	823.0	1899.3	0.0	451	700	0
837.4	71.1	832.8	1896.5	0.0	448	699	0
860.6	71.5	842.5	1893.5	0.0	446	697	0
883.8	72.0	852.3	1890.6	0.0	444	700	0
906.9	72.5	862.3	1887.9	0.0	442	700	0
930.1	72.9	871.8	1884.7	0.0	440	696	0
953.3	73.4	881.2	1881.4	0.0	438	694	0
976.4	73.8	890.8	1878.3	0.0	437	697	0
999.6	74.3	900.7	1875.5	0.0	435	702	0
1022.7	74.8	910.8	1872.7	0.0	433	703	0

DIMENSION BID

DIMENSION BID COILED TUBING SERVICES



DULANG C-15L

SCO

Flow State (continued)

Measured Depth[Flow] <i>m</i>	Temperature	Completion Pressure	Workstring Pressure	Concentric Pressure	Completion Liquid Velocity <i>m</i>	Workstring Liquid Velocity <i>Deg. C</i>	Concentric Liquid Velocity <i>psi g</i>
1045.9	75.2	920.2	1869.4	0.0	431	697	0
1069.1	75.7	929.4	1872.0	0.0	429	778	0
1092.2	76.1	938.7	1868.6	0.0	428	695	0
1115.4	76.5	948.4	1865.4	0.0	426	700	0
1138.6	77.0	958.4	1862.5	0.0	424	704	0
1161.7	77.5	968.5	1859.7	0.0	423	706	0
1184.9	78.0	978.2	1856.5	0.0	421	701	0
1208.1	78.4	987.7	1853.1	0.0	420	698	0
1231.2	78.8	997.3	1849.8	0.0	418	701	0
1254.4	79.3	1007.1	1846.6	0.0	417	703	0
1277.6	79.8	1016.9	1843.4	0.0	415	705	0
1300.7	80.2	1026.9	1840.3	0.0	414	707	0
1323.9	80.7	1037.0	1837.3	0.0	412	708	0
1347.1	81.2	1047.0	1834.2	0.0	411	708	0
1370.2	81.6	1057.0	1831.0	0.0	410	708	0
1393.4	82.1	1067.0	1827.8	0.0	408	708	0
1416.6	82.6	1077.0	1824.6	0.0	407	707	0
1439.7	83.0	1086.9	1821.3	0.0	406	708	0
1462.9	83.5	1097.0	1818.2	0.0	404	710	0
1486.0	84.0	1107.1	1815.0	0.0	403	712	0
1509.2	84.5	1117.4	1811.9	0.0	402	713	0
1532.4	84.9	1127.6	1808.8	0.0	400	712	0
1555.5	85.4	1137.6	1805.5	0.0	399	710	0

DIMENSION BID

DIMENSION BID COILED TUBING SERVICES



DULANG C-15L

SCO

Flow State (continued)

Measured Depth[Flow] <i>m</i>	Temperature	Completion Pressure	Workstring Pressure	Concentric Pressure	Completion Liquid Velocity <i>m</i>	Workstring Liquid Velocity <i>Deg. C</i>	Concentric Liquid Velocity <i>psi g</i>
1578.7	85.9	1147.6	1802.2	0.0	398	711	0
1601.9	86.3	1157.8	1798.9	0.0	397	713	0
1625.0	86.8	1167.9	1795.7	0.0	396	713	0
1648.2	87.3	1177.9	1792.3	0.0	395	711	0
1671.4	87.7	1187.7	1795.1	0.0	393	801	0
1694.5	88.2	1197.5	1797.8	0.0	392	801	0
1717.7	88.6	1207.3	1800.7	0.0	391	801	0
1740.9	89.1	1217.2	1803.5	0.0	390	801	0
1764.0	89.5	1227.1	1806.4	0.0	389	801	0
1787.2	89.9	1238.2	1809.3	0.0	416	801	0
1810.4	90.4	1251.4	1812.2	0.0	497	801	0
1833.5	90.9	1264.6	1815.2	0.0	495	802	0
1856.7	91.3	1277.9	1818.1	0.0	494	802	0
1879.8	91.8	1291.2	1814.7	0.0	493	713	0
1903.0	92.2	1304.6	1811.3	0.0	492	714	0
1926.2	92.7	1318.0	1807.9	0.0	491	714	0
1949.3	93.1	1331.4	1804.5	0.0	489	715	0
1972.5	93.6	1345.0	1801.1	0.0	488	716	0
1995.7	94.1	1358.5	1797.7	0.0	487	717	0
2018.8	94.5	1372.1	1794.3	0.0	486	718	0
2042.0	95.0	1385.7	1790.9	0.0	581	718	0
2062.0	95.4	1397.6	1788.0	0.0	580	719	0
2071.3	95.6	1403.2	1786.6	0.0	483	720	0

DIMENSION BID	DIMENSION BID COILED TUBING SERVICES		
	DULANG C-15L	SCO	

Flow State (continued)

Measured Depth[Flow] <i>m</i>	Temperature	Completion Pressure	Workstring Pressure	Concentric Pressure	Completion Liquid Velocity <i>m</i>	Workstring Liquid Velocity <i>Deg. C</i>	Concentric Liquid Velocity <i>psi g</i>
2094.5	96.1	1417.0	1783.3	0.0	482	720	0
2117.7	96.5	1430.8	1779.9	0.0	481	722	0
2140.8	97.0	1444.7	1776.6	0.0	480	723	0
2164.0	97.5	1458.7	1773.2	0.0	574	723	0
2178.8	97.8	1467.7	1771.1	0.0	479	724	0
2202.0	98.3	1481.7	1767.8	0.0	572	725	0
2216.8	98.6	1490.8	1765.6	0.0	473	726	0
2240.0	99.1	1504.9	1762.3	0.0	566	727	0
2256.7	99.4	1515.1	1760.0	0.0	471	727	0
2257.0	99.5	1515.2	1759.9	0.0	264	10326	0
2259.8	99.5	1516.9	0.0	0.0	0	0	0
2283.0	100.0	1531.0	0.0	0.0	0	0	0
2298.8	100.3	1540.7	0.0	0.0	0	0	0
2322.0	100.8	1554.9	0.0	0.0	0	0	0
2323.0	100.9	1555.5	0.0	0.0	0	0	0

Solids Bulk Cross Sectional Area

CTran Analysis

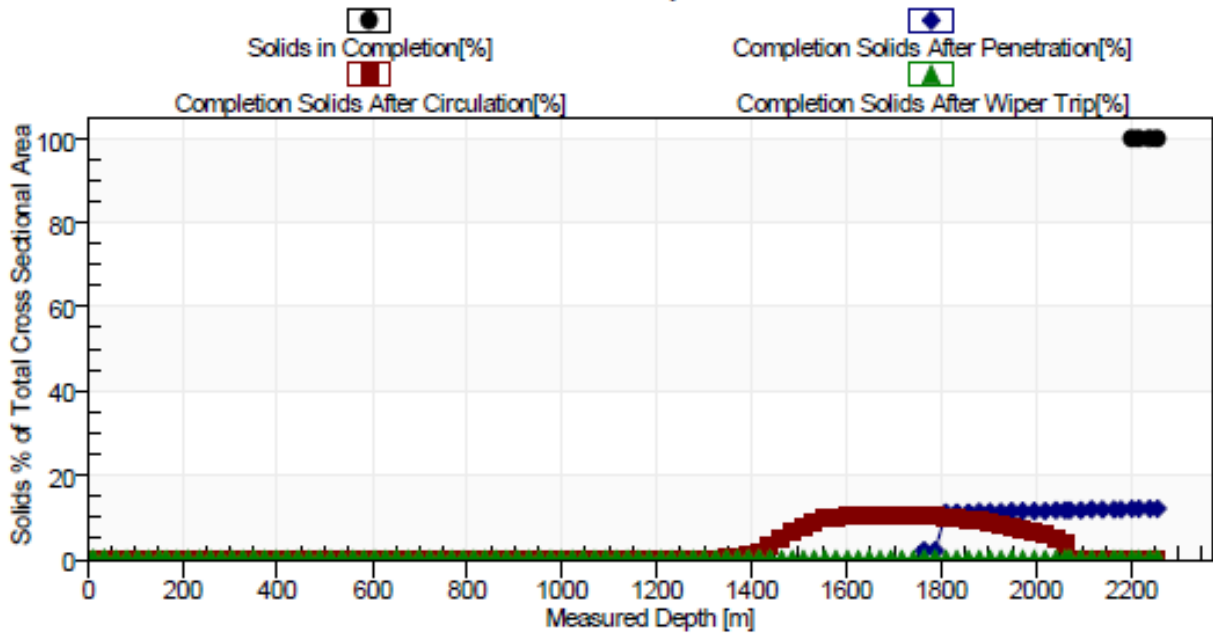

Solids Removal after Penetration to Target Depth

CTran Analysis [Transient response during Circulation and Wiper Trip]

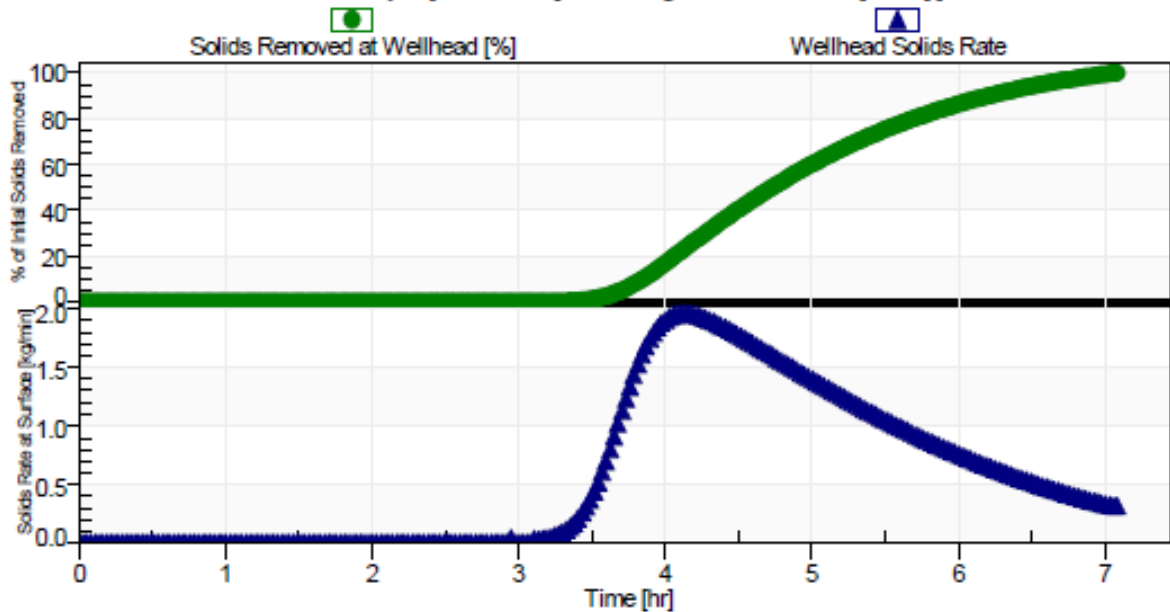

Tripping Speed to be used while Pulling Out of Hole
CTran Analysis

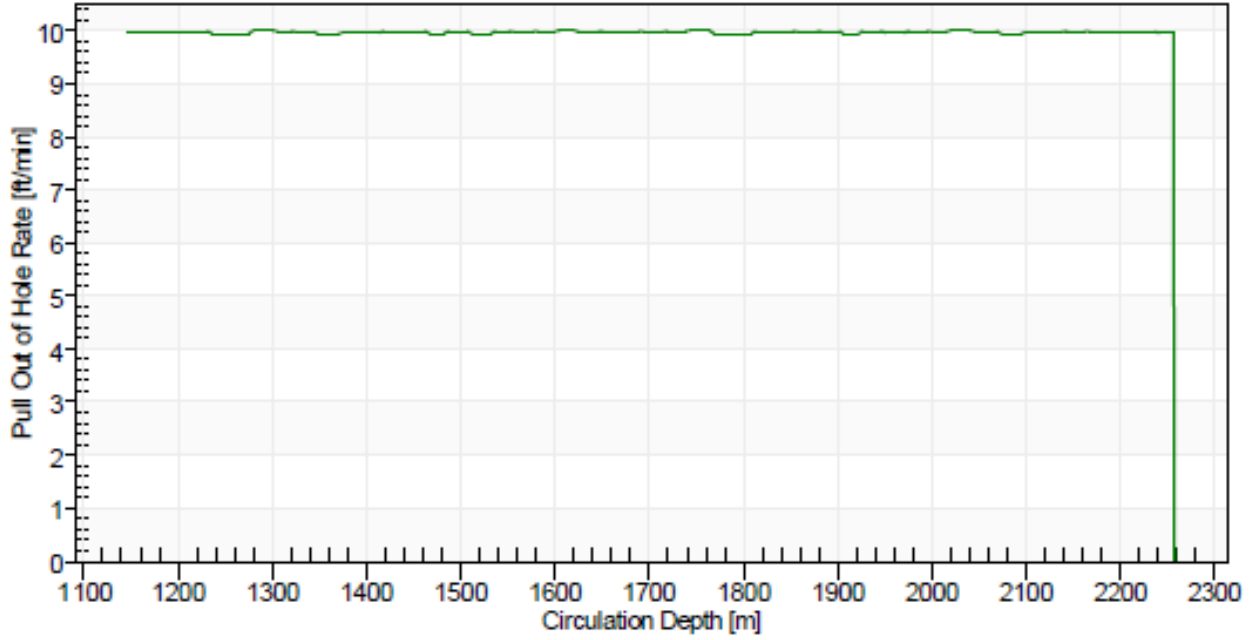

Cleanout from plug until EOT

Flow Summary

SUMMARY OF FLOW RESULTS

Produced Fluids	
Pressure known at:	Perforations
Production Mode:	No Production
Fluid Composition:	Oil Only
Circulated Fluids	
Fluid Composition:	Nitrified Water
Liquid:	0.70 bbl/min
Solids:	0.00 bbl/min
Gas:	300.0 scf/min
Circulation Point:	2323.00 m
HHP Required :	42.22 HP

COMPLETION:

Wellhead Pressure.....	324.5 psi g
Hydrostatic pressure loss.....	830.3 psi
Friction pressure loss.....	377.9 psi
Kinetic pressure loss.....	-2.6 psi
Restriction pressure loss.....	0.9 psi
Equivalent Circulation Density[ECD]...	5.61 lb/gal (US)
Perforation Pressure.....	1531.0 psi g
Hydrostatic pressure loss.....	16.0 psi
Friction pressure loss.....	8.9 psi
Kinetic pressure loss.....	-0.1 psi
Restriction pressure loss.....	0.2 psi
Bottom Hole Pressure.....	1556.0 psi g
FROM CIRCULATION POINT TO WELLHEAD:	
Liquid transit time.....	16 min
Gas transit time.....	13 min
Annular volume.....	27.5 bbl

Volume below circulation point.....	0.0 bbl
Total liquid volume.....	12.7 bbl
Total gas volume.....	14.7 bbl
(Surface equivalent).....	4264.0 scf

WORKSTRING:

Liquid:	0.7000 bbl/min
Gas:	0.43 MMscf/day
Pressure at reel rotating joint.....	2446.9 psi g
Friction pressure loss on reel.....	654.8 psi
Hydrostatic pressure loss on reel.....	0.1 psi

Pressure inside WS at Gooseneck.....	1792.1 psi g
Hydrostatic pressure loss.....	-1176.3 psi
Friction pressure loss.....	1169.1 psi
Equivalent Circulation Density[ECD]...	0.03 lb/gal (US)

BHA total pressure loss	243.3 psi
BHA Hydrostatic loss	-0.1 psi
BHA Friction loss	0.2 psi
Nozzle	243.2 psi

Circulation Point pressure	1556.0 psi g
----------------------------------	--------------

FROM REEL ROTATING JOINT TO CIRCULATION POINT:

Liquid transit time.....	17 min
Gas transit time.....	15 min
Displacement Volume.....	16.7 bbl
Internal Volume.....	18.8 bbl
Internal liquid volume.....	12.0 bbl
Internal gas volume.....	6.8 bbl
(Surface equivalent).....	4528.1 scf

Length of Workstring on reel.....	1365.30 m
-----------------------------------	-----------

Ctran Summary

SUMMARY OF HOLE CLEANING RESULTS

Initial Condition:

% of fill interval occupied by solids before cleanout ...	100.0 %
Top of fill	2257.01 m
Deepest Circulation point	2323.00 m
Bottom of fill	2323.00 m
Initial Volume of Solids.....	1.3 bbl
Initial Mass of Solids.....	642.3 lb
Solids type:	Mud Residue/Formation Fines
Fluid Description:	Nitrified Water

Penetration Hole Cleaning Mode:

Penetration rate.....	5.0 ft/min
Penetration time.....	0.72 hr
Solids volume in the well after penetration	1.3 bbl
Solids mass in the well after penetration	642.3 lb

Circulation Hole Cleaning Mode:

Hole circulation time	1.00 hr
Solids volume in the well after circulation.....	1.3 bbl
Solids mass in the well after circulation.....	642.3 lb

Wiper Trip Hole Cleaning Mode:

Wiper Trip Scheme:	User Specified rate, Tornado not
Wiper trip time	6.41 hr
Solids volume in the well after wiper trip	0.0 bbl
Solids mass in the well after wiper trip	0.0 lb

Volume of Fluids Pumped During Penetration, Circulation & Wiper Trip:

Gas volume	146400.0 scf
Liquid Volume	341.6 bbl
Penetration, Circulation & Wiper Trip time	8.13 hr

Circulation results at point of Maximum Solids Head:

BHA Depth	1793.44 m
Elapsed time	3.9033 hr
Wellhead Pressure	281.4 psi g
Additional Head created by Solids.....	18.7 psi

Maximum % solids circulated up hole was 0.9%.

This occurred at a measured depth of	1793.75 m
after the transient had run for	0.0 hr

DIMENSION BID

DIMENSION BID COILED TUBING SERVICES



DULANG C-15L

SCO

Flow State

Measured Depth[Flow] <i>m</i>	Temperature	Completion Pressure	Workstring Pressure	Concentric Pressure	Completion Liquid Velocity <i>m</i>	Workstring Liquid Velocity <i>Deg. C</i>	Concentric Liquid Velocity <i>psi g</i>
0.0	40.0	324.5	1792.1	0.0	710	840	0
16.2	40.8	335.4	1799.8	0.0	697	840	0
38.7	41.8	350.5	1810.7	0.0	680	841	0
61.3	42.9	365.8	1821.5	0.0	664	841	0
83.8	44.0	381.1	1832.4	0.0	649	841	0
106.4	45.0	396.5	1843.1	0.0	635	843	0
128.9	46.1	411.9	1853.8	0.0	623	843	0
151.5	47.2	427.4	1864.6	0.0	732	843	0
169.7	48.0	440.1	1873.3	0.0	601	842	0
192.2	49.1	455.9	1884.2	0.0	591	842	0
214.8	50.2	471.7	1895.1	0.0	580	842	0
237.3	51.2	487.7	1906.0	0.0	571	842	0
259.9	52.3	503.7	1916.9	0.0	562	843	0
282.4	53.4	519.8	1927.7	0.0	553	844	0
305.0	54.4	535.8	1938.4	0.0	653	846	0
305.2	54.4	536.1	1938.5	0.0	545	847	0
327.8	55.5	552.2	1948.9	0.0	538	848	0
350.4	56.5	568.1	1959.0	0.0	530	852	0
372.9	57.5	583.8	1968.6	0.0	524	855	0
395.5	58.5	599.4	1977.9	0.0	517	859	0
418.0	59.4	614.7	1986.6	0.0	511	862	0
440.6	60.3	629.7	1994.8	0.0	506	866	0
463.1	61.2	644.4	2002.5	0.0	501	869	0

DIMENSION BID

DIMENSION BID COILED TUBING SERVICES



DULANG C-15L

SCO

Flow State (continued)

Measured Depth[Flow] <i>m</i>	Temperature	Completion Pressure	Workstring Pressure	Concentric Pressure	Completion Liquid Velocity <i>m</i>	Workstring Liquid Velocity <i>Deg. C</i>	Concentric Liquid Velocity <i>psi g</i>
485.7	62.1	658.9	2009.8	0.0	496	871	0
508.2	62.9	673.2	2016.6	0.0	491	873	0
530.8	63.7	687.0	2022.7	0.0	487	875	0
553.4	64.5	700.2	2022.9	0.0	483	755	0
575.9	65.2	712.9	2022.7	0.0	479	745	0
598.5	65.9	725.0	2022.1	0.0	476	734	0
621.0	66.5	736.3	2021.0	0.0	472	722	0
643.6	67.0	746.8	2019.3	0.0	470	709	0
666.1	67.5	756.7	2017.1	0.0	467	699	0
688.7	68.0	766.5	2014.8	0.0	464	697	0
711.2	68.5	776.3	2012.6	0.0	462	696	0
733.8	68.9	785.7	2010.0	0.0	460	693	0
756.4	69.4	795.0	2007.3	0.0	457	691	0
778.9	69.9	804.5	2004.7	0.0	455	693	0
801.5	70.3	814.1	2002.2	0.0	453	695	0
824.0	70.8	823.8	1999.8	0.0	451	696	0
846.6	71.2	833.2	1997.1	0.0	449	694	0
869.1	71.7	842.7	1994.5	0.0	447	694	0
891.7	72.2	852.3	1991.9	0.0	444	697	0
914.2	72.6	862.0	1989.4	0.0	442	696	0
936.8	73.1	871.1	1986.4	0.0	441	691	0
959.4	73.5	880.3	1983.4	0.0	439	691	0
981.9	73.9	889.7	1980.6	0.0	437	695	0

DIMENSION BID

DIMENSION BID COILED TUBING SERVICES



DULANG C-15L

SCO

Flow State (continued)

Measured Depth[Flow] <i>m</i>	Temperature	Completion Pressure	Workstring Pressure	Concentric Pressure	Completion Liquid Velocity <i>m</i>	Workstring Liquid Velocity <i>Deg. C</i>	Concentric Liquid Velocity <i>psi g</i>
1004.5	74.4	899.4	1978.0	0.0	435	699	0
1027.0	74.9	909.2	1975.5	0.0	433	698	0
1049.6	75.3	918.3	1972.4	0.0	432	692	0
1072.1	75.7	927.2	1969.2	0.0	430	689	0
1094.7	76.1	936.3	1966.0	0.0	428	692	0
1117.2	76.6	945.7	1963.2	0.0	427	697	0
1139.8	77.0	955.5	1960.5	0.0	425	701	0
1162.3	77.5	965.3	1957.9	0.0	423	702	0
1184.9	78.0	974.7	1955.0	0.0	422	698	0
1207.5	78.4	984.0	1951.9	0.0	420	695	0
1230.0	78.8	993.3	1948.8	0.0	419	697	0
1252.6	79.3	1002.8	1945.9	0.0	417	699	0
1275.1	79.7	1012.4	1943.0	0.0	416	701	0
1297.7	80.2	1022.1	1940.2	0.0	415	703	0
1320.2	80.6	1031.9	1937.4	0.0	413	704	0
1342.8	81.1	1041.7	1934.6	0.0	412	704	0
1365.3	81.5	1051.4	1931.7	0.0	410	704	0
1387.9	82.0	1061.1	1928.8	0.0	409	704	0
1410.5	82.5	1070.8	1925.9	0.0	408	704	0
1433.0	82.9	1080.5	1922.9	0.0	406	704	0
1455.6	83.4	1090.2	1920.0	0.0	405	705	0
1478.1	83.8	1100.1	1917.1	0.0	404	707	0
1500.7	84.3	1110.1	1914.3	0.0	403	709	0

DIMENSION BID

DIMENSION BID COILED TUBING SERVICES



DULANG C-15L

SCO

Flow State (continued)

Measured Depth[Flow] <i>m</i>	Temperature	Completion Pressure	Workstring Pressure	Concentric Pressure	Completion Liquid Velocity <i>m</i>	Workstring Liquid Velocity <i>Deg. C</i>	Concentric Liquid Velocity <i>psi g</i>
1523.2	84.8	1120.1	1911.5	0.0	401	709	0
1545.8	85.2	1129.8	1908.5	0.0	400	707	0
1568.3	85.7	1139.6	1905.5	0.0	399	706	0
1590.9	86.1	1149.4	1902.5	0.0	398	708	0
1613.5	86.6	1159.3	1899.6	0.0	397	709	0
1636.0	87.0	1169.1	1896.6	0.0	396	708	0
1658.6	87.5	1178.7	1893.4	0.0	395	706	0
1681.1	87.9	1188.3	1890.1	0.0	394	705	0
1703.7	88.3	1197.8	1886.9	0.0	393	706	0
1726.2	88.8	1207.4	1883.6	0.0	392	706	0
1748.8	89.2	1217.0	1880.4	0.0	390	707	0
1771.3	89.6	1228.9	1877.1	0.0	486	708	0
1793.9	90.1	1241.7	1873.9	0.0	498	708	0
1816.4	90.5	1254.5	1870.6	0.0	496	709	0
1839.0	91.0	1267.4	1867.4	0.0	495	710	0
1861.6	91.4	1280.3	1864.1	0.0	494	710	0
1884.1	91.8	1293.3	1860.9	0.0	493	711	0
1906.7	92.3	1306.3	1857.7	0.0	492	712	0
1929.2	92.7	1319.4	1854.4	0.0	490	713	0
1951.8	93.2	1332.5	1851.2	0.0	489	714	0
1974.3	93.6	1345.6	1848.0	0.0	488	714	0
1996.9	94.1	1358.8	1844.8	0.0	487	715	0
2019.4	94.5	1372.1	1841.6	0.0	486	716	0

Flow State (continued)

Measured Depth[Flow] <i>m</i>	Temperature	Completion Pressure	Workstring Pressure	Concentric Pressure	Completion Liquid Velocity <i>m</i>	Workstring Liquid Velocity <i>Deg. C</i>	Concentric Liquid Velocity <i>psi g</i>
2042.0	95.0	1385.3	1838.4	0.0	581	716	0
2062.0	95.4	1397.2	1835.5	0.0	580	717	0
2073.8	95.6	1404.3	1833.9	0.0	483	718	0
2096.3	96.1	1417.7	1830.7	0.0	482	719	0
2118.9	96.6	1431.1	1827.5	0.0	481	720	0
2141.4	97.0	1444.7	1824.3	0.0	480	721	0
2164.0	97.5	1458.3	1821.2	0.0	574	722	0
2179.4	97.8	1467.7	1819.0	0.0	479	722	0
2202.0	98.3	1481.3	1815.9	0.0	572	723	0
2217.4	98.6	1490.8	1813.8	0.0	477	724	0
2240.0	99.1	1504.6	1810.7	0.0	570	725	0
2257.0	99.5	1515.1	1808.3	0.0	569	725	0
2260.4	99.5	1517.2	1807.8	0.0	471	725	0
2283.0	100.0	1531.0	1804.7	0.0	470	726	0
2299.4	100.3	1541.2	1802.5	0.0	471	727	0
2322.0	100.8	1555.2	1799.4	0.0	620	728	0
2322.7	100.8	1555.8	1799.3	0.0	470	728	0
2323.0	100.9	1556.0	1799.2	0.0	470	10342	0

Solids Bulk Cross Sectional Area

CTran Analysis

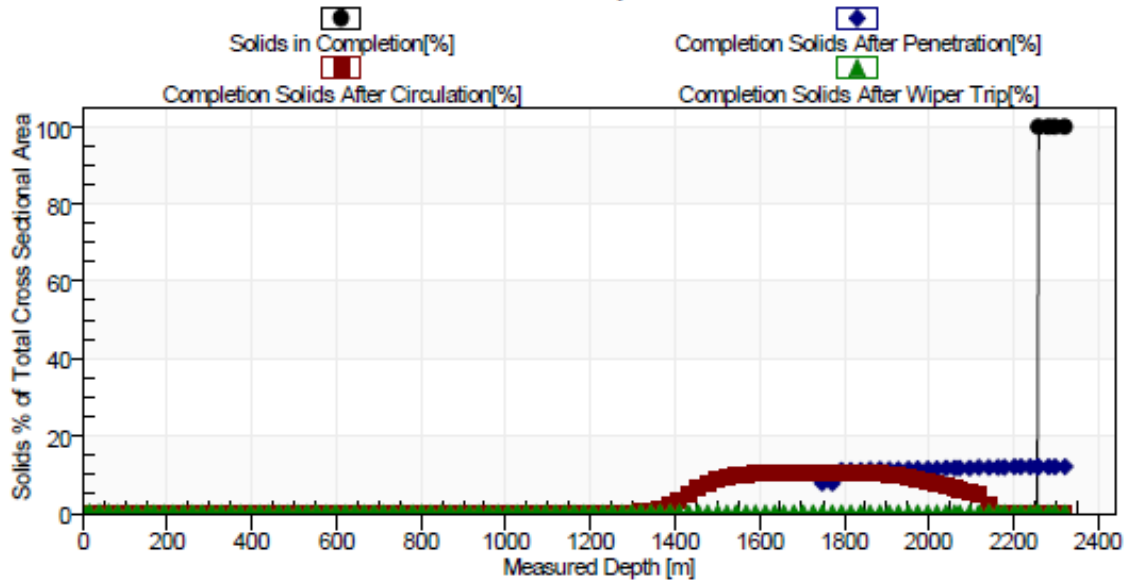

Solids Removal after Penetration to Target Depth

CTran Analysis [Transient response during Circulation and Wiper Trip]

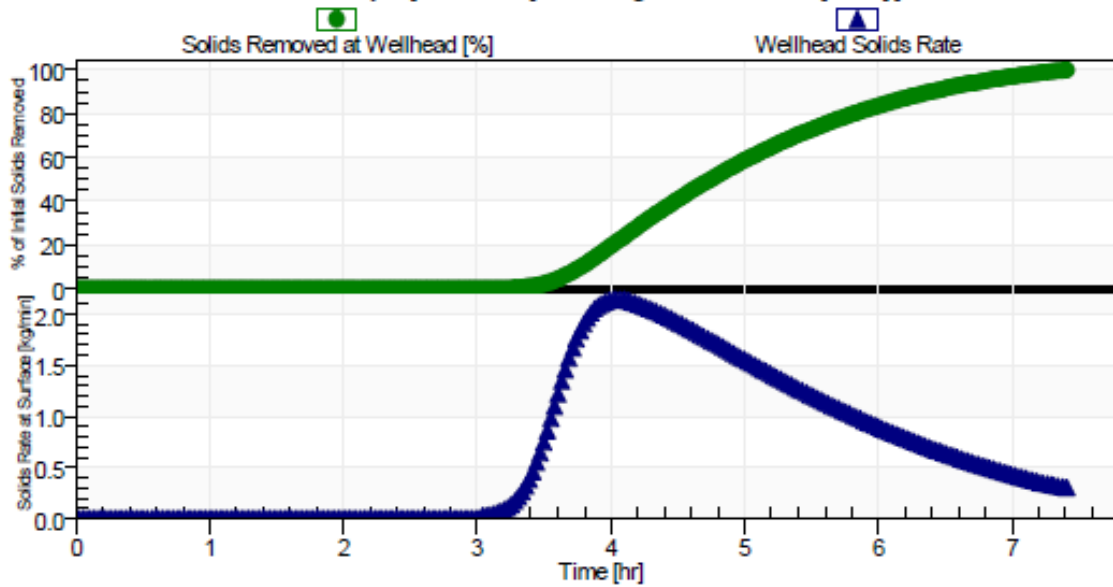

Tripping Speed to be used while Pulling Out of Hole
CTran Analysis

