

TSA THEORETICAL ASSESSMENT

Presented By
Mohammad Farhan bin Saifudin

Basic of Wireline – Equipment & Operation

- ① Slickline Introduction
- ② Basic Safety
- ③ Pressure Control Equipment
- ④ Surface Equipment
- ⑤ Downhole Equipment
- ⑥ Safety Sharing

Slickline Introduction

- **Well Intervention**

- operation carried out during or end of productive life.
- improve performance of production well.
- provide access to stranded.
- additional hydrocarbon reserves.

- **Typical Intervention Services**

- Wireline (Slickline, E-line).
- Well services (Coiled Tubing).
- Hydraulic Workover.

Slickline History

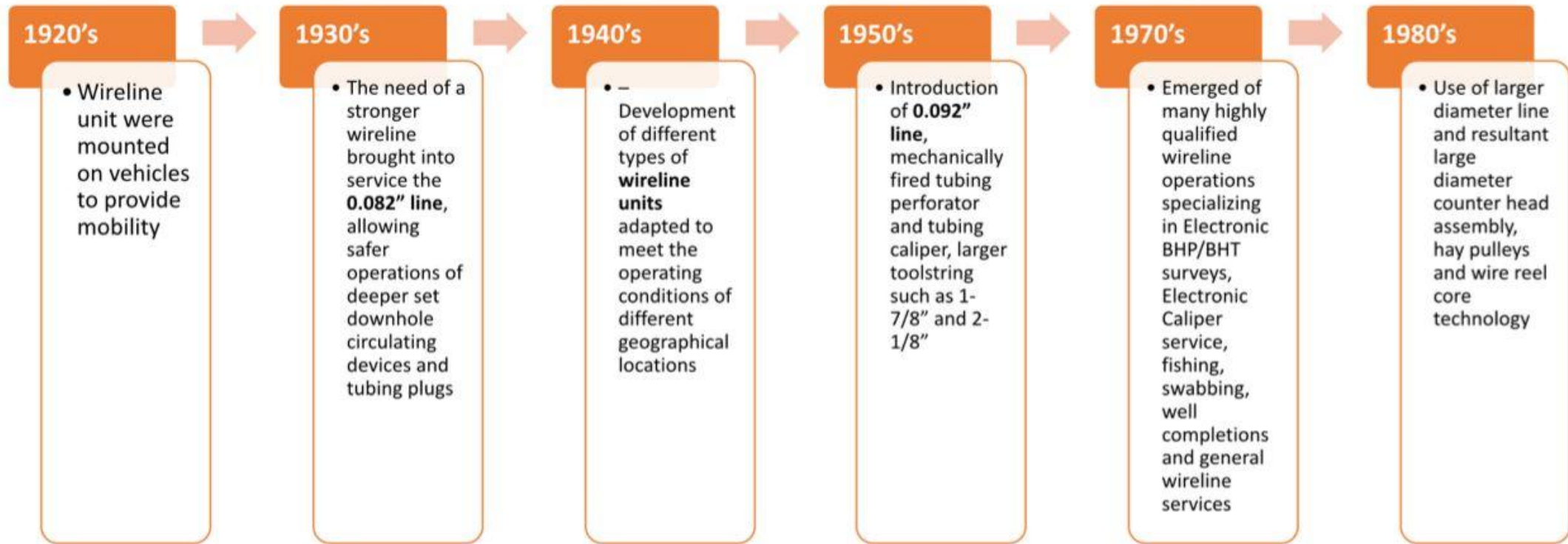

- **What is Slickline?**
 - single strand wire used to run toolstring in well
 - used during well drilling operations
 - long, smooth, unbraided wire, shiny, silver/chrome look a like
- **Advantages:**
 - low cost, basic technology
 - easy to transport the equipment
 - small crew members
 - much faster than other intervention techniques
- **Disadvantages:**
 - low strength of wire
 - inability to rotate or circulate
 - difficult to use in high angle wells

-diameter of wire commonly 0.092", 0.108", 0.125", 0.140", 0.160"

-length of wire available is 18000ft, 20000ft, 25000ft, 30000ft.

-type of wire:

- a) ZERON (100 HS stainless steel)
- b) EIPS (Carbon Steel EIPS Grade)
- c) ZAPP (SUPA 75 Alloy)

-always advisable to keep wire size small as possible:

- a) reduces load of its own weight
- b) can be run over smaller diameter sheaves, spools, reels, without overstress bending
- c) to keep reel drum size minimum

Basic Safety

- 7 Safety Policy
 - Driving policy
 - Drugs and Alcohol Policy
 - Harrassment in Workplace Policy
 - HSSE Policy
 - PPE Policy
 - Smoking and Vaping Policy
 - Stop Work Policy

Personal Protective Equipment

- to minimize exposure to hazard
- include coverall, hard hat, safety glass, safety shoe, impact gloves and ear plugs
- all PPEs must follow standard requirement in industry
- PPE includes:
 - eye & face protection
 - hearing protection (over 90dB)
 - hand & skin protection
 - body protection
 - head protection
 - foot protection
 - respiratory protection



Hydrogen Sulphide (H₂S)

- **Definition**

- H₂S is colourless, highly flammable and toxic gas that liquefied under pressure
- detectable in low concentration with “rotten egg” odour
- may affects sense smell and cannot be detected
- it is toxic by inhalation a skin/eye absorption

- **Responsibilities**

Employer	Employee
<ul style="list-style-type: none">-provide training-frequently remind of H₂S awareness-establish and communicate clear expectation and goals of acceptable safety performance-provide top-of-the-line monitoring and PPE	<ul style="list-style-type: none">-comply with working in H₂S environment regulations-make sure not influence by intoxicant-crew member should help anyone may be injured or overcome by toxic gases-always put Self-Contained Breathing Apparatus (SCBA) before helping anyone-go to Safe Briefing Area when alarm sounded-report any H₂S indications

- **Definition**

- work in any place where a person could fall a distance to cause personal injury
- working at height of above ground/floor level, could fall from an edge with an opening or fragile surface, and could fall from ground level into an opening in floor or a hole

- **Responsibilities**

Employer	Employee
<ul style="list-style-type: none">-ensure employees are trained to work at height-check that all equipment for WAH are checked and inspected-ensure work is planned, organized and supervised at all times-maintain and replace PPE when required-make sure WAH workplace are safe	<ul style="list-style-type: none">-comply with WAH regulations-are not under influenced of intoxicant-use WAH equipment or tools they have access to which prevents falls or dropping tools-report any known dangers in workplace-behave in a responsible manner

- Hazard Identification

- ❖ to keep workplace safe and healthy
- ❖ to look for hazard in advance as part of their risk management plan to prevent potential hazards

- Risk Assessment

- ❖ is the process of evaluating the risk to safety and health from hazards at work

- Determination Control

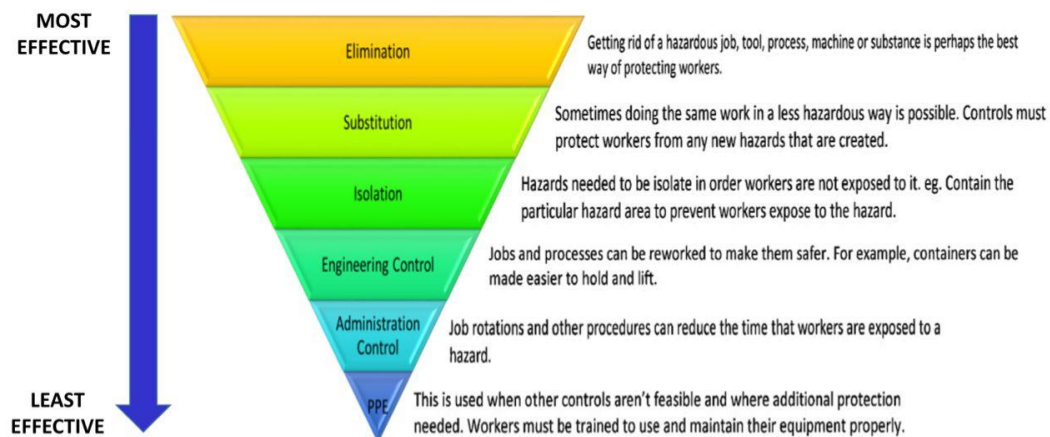

- Process of cleaning site and ensure all materials or equipment are kept at their suitable place after been used
- Importance of Housekeeping
 - to reduce illnesses and injuries and promotes positive behaviors, habits, and attitudes
 - improve productivity
 - to reduce the hazard
 - better hygienic conditions
 - to reduce exposures to hazardous products (dust, vapors, etc)
 - more efficient equipment and maintenance

- Known as ACT card, UCUA card
- Step to write Hazard Hunt:
 - observe unsafe act/condition
 - intervene/action
 - findings writing
 - agreed solution
 - follow up (if any)
 - closure

Neu Dimension - EMO Onshore Hazard Hunt E-Card

Your response has been recorded.

[Submit another response](#)

This content is neither created nor endorsed by Google.
[Report Abuse](#) - [Terms of Service](#) - [Privacy Policy](#)

Google Forms

Job Hazard Analysis (JHA)

- A technique to focus on job tasks as a way to identify hazard before occur
- After identify hazard, can take step to eliminate or reduce hazard to acceptable risk
- Activities involved for JHA:
 - chipping
 - painting
 - lifting
 - spooling
 - pressure test

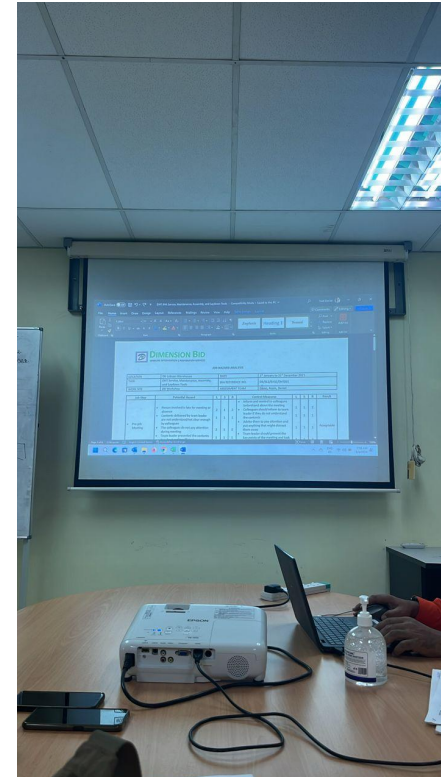

Permit To Work (PTW)

- A written record which authorized specific work at specific location for a specific period
- Following permit used in DB's daily operation (onshore and offshore)
 - hot work permit
 - cold work permit
 - electrical work permit
 - radioactive work permit
 - lifting permit

Pressure Control Equipment

- equipment that helps in maintaining the optimal pressure levels inside a wellbore
- used to flowing oil well, gas well, water injection well and coal seams well for wire logging with pressure
- mainly consist of:
 - stuffing box
 - lubricator
 - quick test sub (QTS)
 - blow out preventor (BOP)
 - ball valve
 - pump in tee & low torque valve
 - crossover & wellhead adapter
 - pressure test unit (PTU)
 - wellhead control panel

PCE Configuration

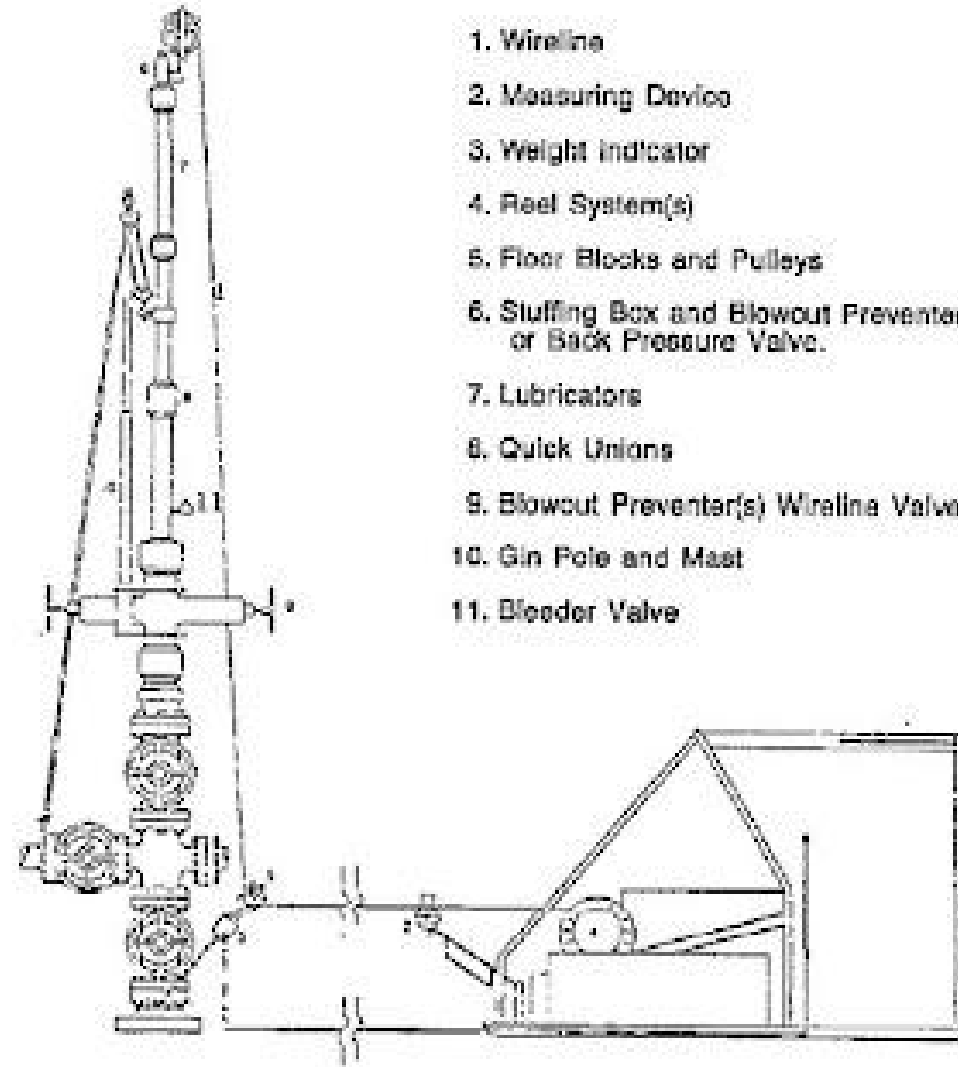
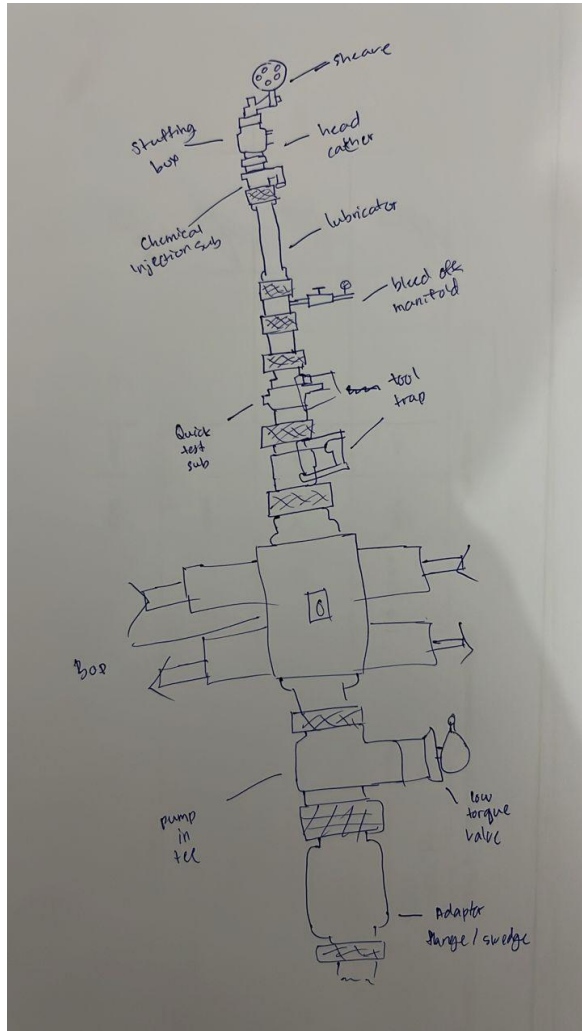

1. Wireline
2. Measuring Device
3. Weight Indicator
4. Reel System(s)
5. Floor Blocks and Pulleys
6. Stuffing Box and Blowout Preventer or Back Pressure Valve.
7. Lubricators
8. Quick Unions
9. Blowout Preventer(s) Wireline Valve
10. Gin Pole and Mast
11. Bleeder Valve

- Connections to assemble lubricator and related equipment, they are assemble by hand
- O-ring on pin section to seal into the box
- Collar has internal ACME thread to match external thread on box
- Differences of Otis and Bowen:
 - external - holes
 - internal - angle (Otis 45*, Bowen 90*)
 - pin diameter (Otis 3.5" , Bowen 4.375")
- Eg. Bowen 5.5"- 4 - 4.375"
- Eg 5-4 ACME thread = 5" bore ID with 4 TPI
- Common type in DB, Otis, Bowen, Elmar type
- 5k psi WP

Pin

Box

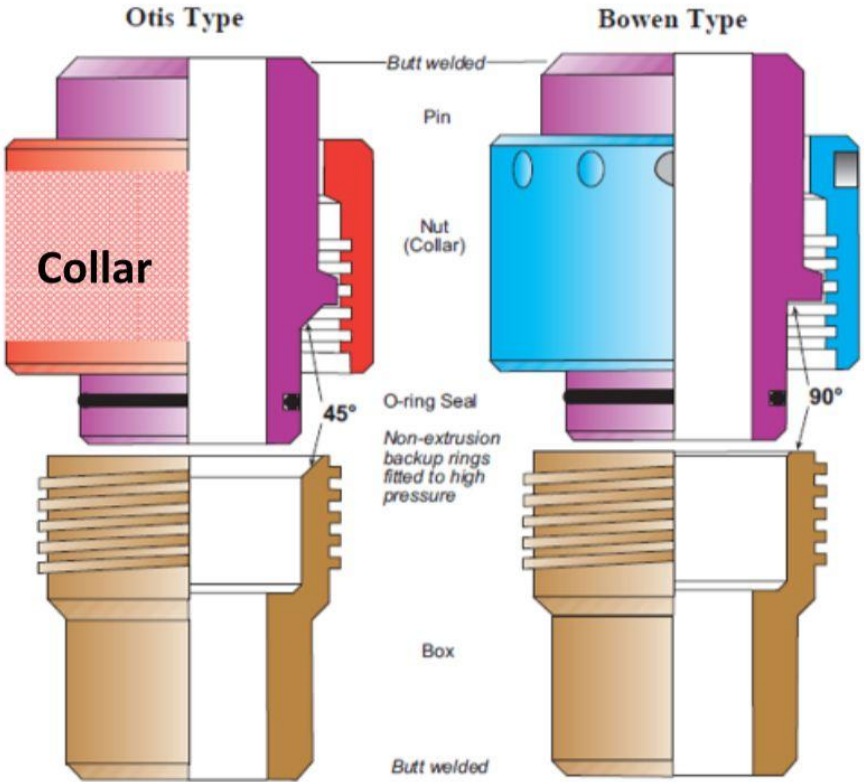

OTIS QU

BOWEN QU

ELMAR QU

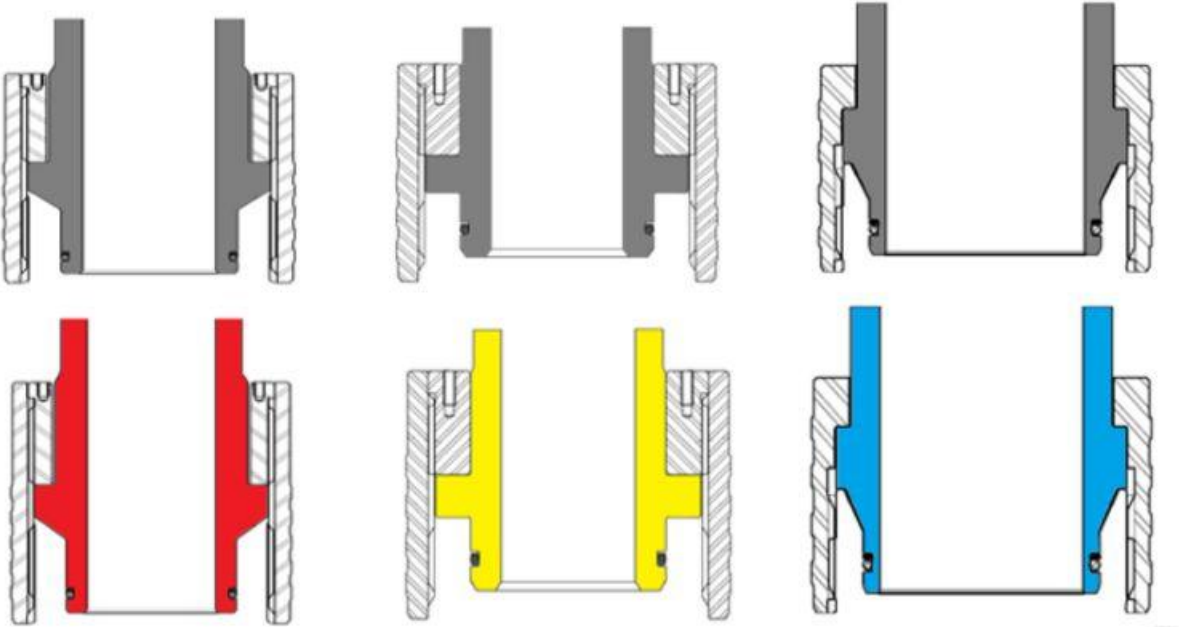

- Allow wireline to enter well under pressure and a primary barrier
- Sheave catch wire if suddenly snaps in the hole which BOP plunger force up by well pressure and seal againsts lower gland
- Available for all wire sizes, and from 5K psi to 15K psi WP
- Piston forced downward againsts spring when received pressure from above
- This action transmitted to upper gland cause packing to squeeze wireline

Stuffing Box

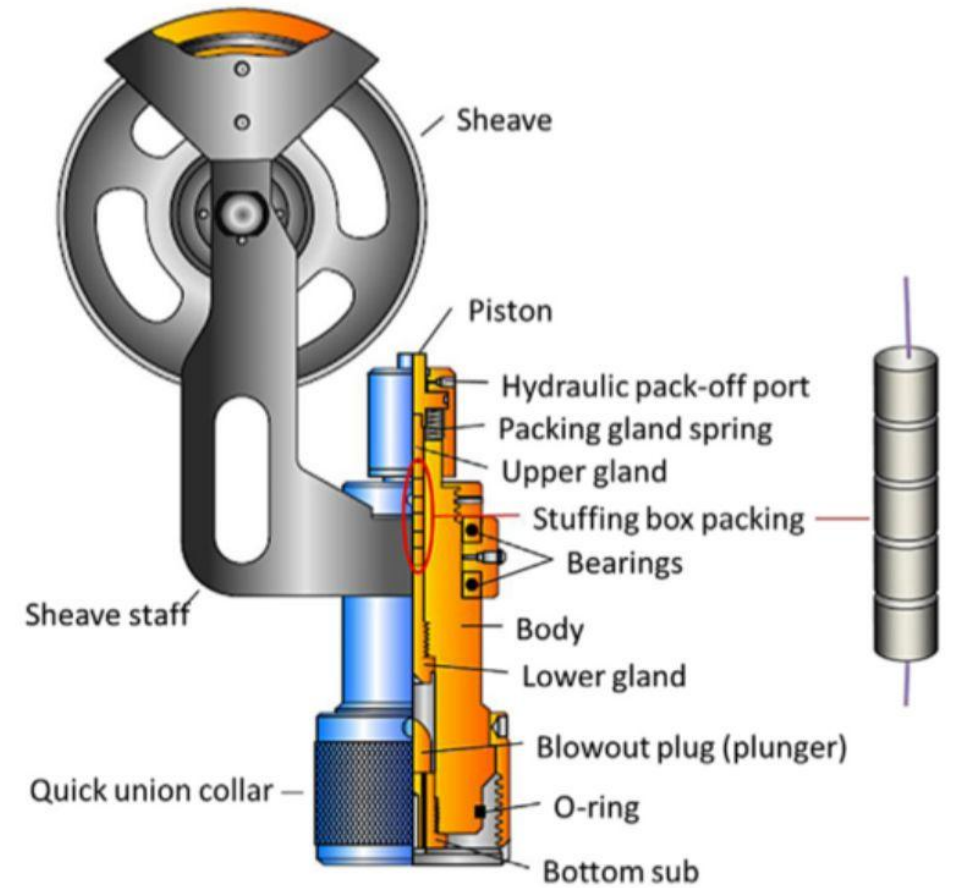

- Provide space for tools to be contained in well under pressure
- Lubricator connection should be longer than toolstring
- ID lubricator should be 0.15" to 0.25" larger than OD largest tool
- Ported lubricator should be at lowermost
- Standard length is 8ft, but shorter sections (pup) is 4 to 2ft
- If lubricator has 2 fittings:
 - to monitor pressure
 - to bleed off pressure

Working pressure (psi)	Test pressure (psi)
3000	4500
5000	7500
10000	15000
15000	22500



- Types of Lubricator

- Conventional Lubricator

- consist of heavy wall with QU connection thread, seal using o-ring, metal to metal seal
 - this type is rugged reliable and good rigidity

- Slimline Lubricator

- consist slender (optimum wall thickness) with QU connection thread, seal using o-ring, metal to metal seal
 - not as rugged as conventional type, versatility is same

- Lightweight Lubricator

- consist of very light duplex stainless steel tube with smaller than normal QU connection thread, seal using o-ring, metal to metal seal
 - exceptional lightweight, easy handling and rig up
 - not as rigid as other type, handle with care to avoid excessive bending, which resulted wire abrading
 - not recommend for slickline

- Above BOP to insert and retrieve tool from well
- First test to check integrity and another test to verify integrity of joint by connecting hydraulic hand-pump to the port and testing the joint O-ring seal from the outside
- Pressure testing: Hydrotest, Function Test

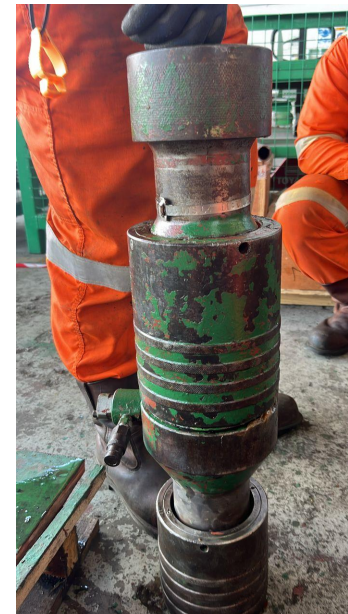
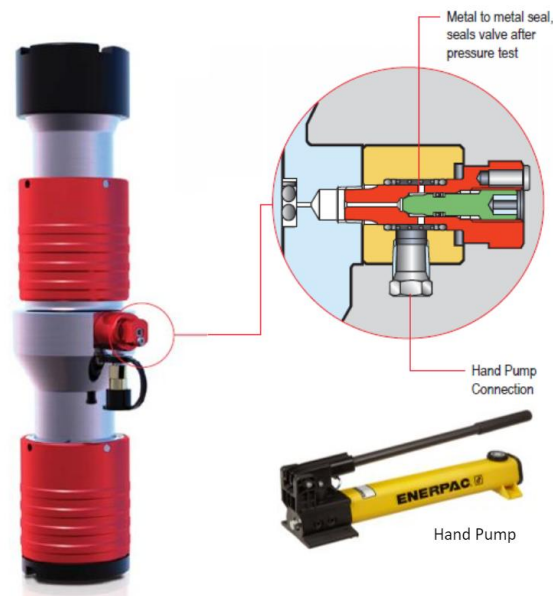

Blow Out Preventer (BOP)

- Known as wireline valve, installed between tree connection and lower lubricator
- Function:
 - enable well pressure to be isolated without cutting the wire by closing the MV
 - permit the assembly of wireline cutter above BOP rams and dropping if wireline stuck
 - allow slickline work to be conducted while containing well pressure on surface with wire
- Mechanical and hydraulic force applied to close the rams which seal against wire
- Has 2 fittings on each ram to connect hydraulic hose to open and close position
- Hydraulically actuated used because of speed closing action and ease of operation
- Will only hold pressure from below
- Size that commonly used are 3" , 4" and 7"

Blow Out Preventer (BOP)

- Fitted with equalizing valve to equalize pressure between lubricator and well when opening rams to continue operation
- If rams opened without equalization, pressure surge could blow toolstring or wire
- Must be pressure tested and inspection checking before operation
- Use blind rams rubber insert on sealing faces to seal with or without wire across rams
- WP is 5K psi and TP is 10K psi

Blow Out Preventer (BOP)

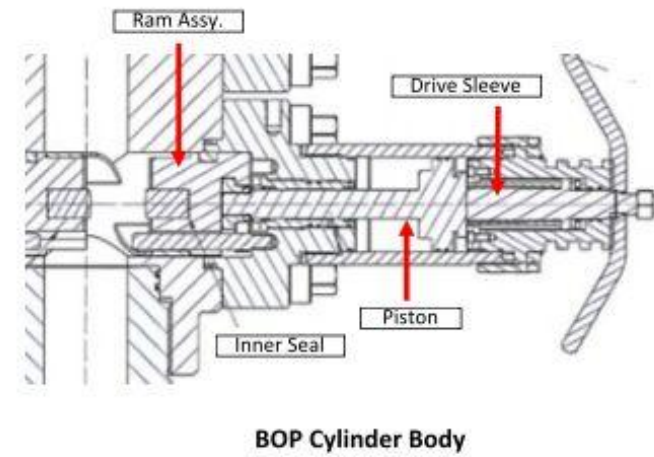
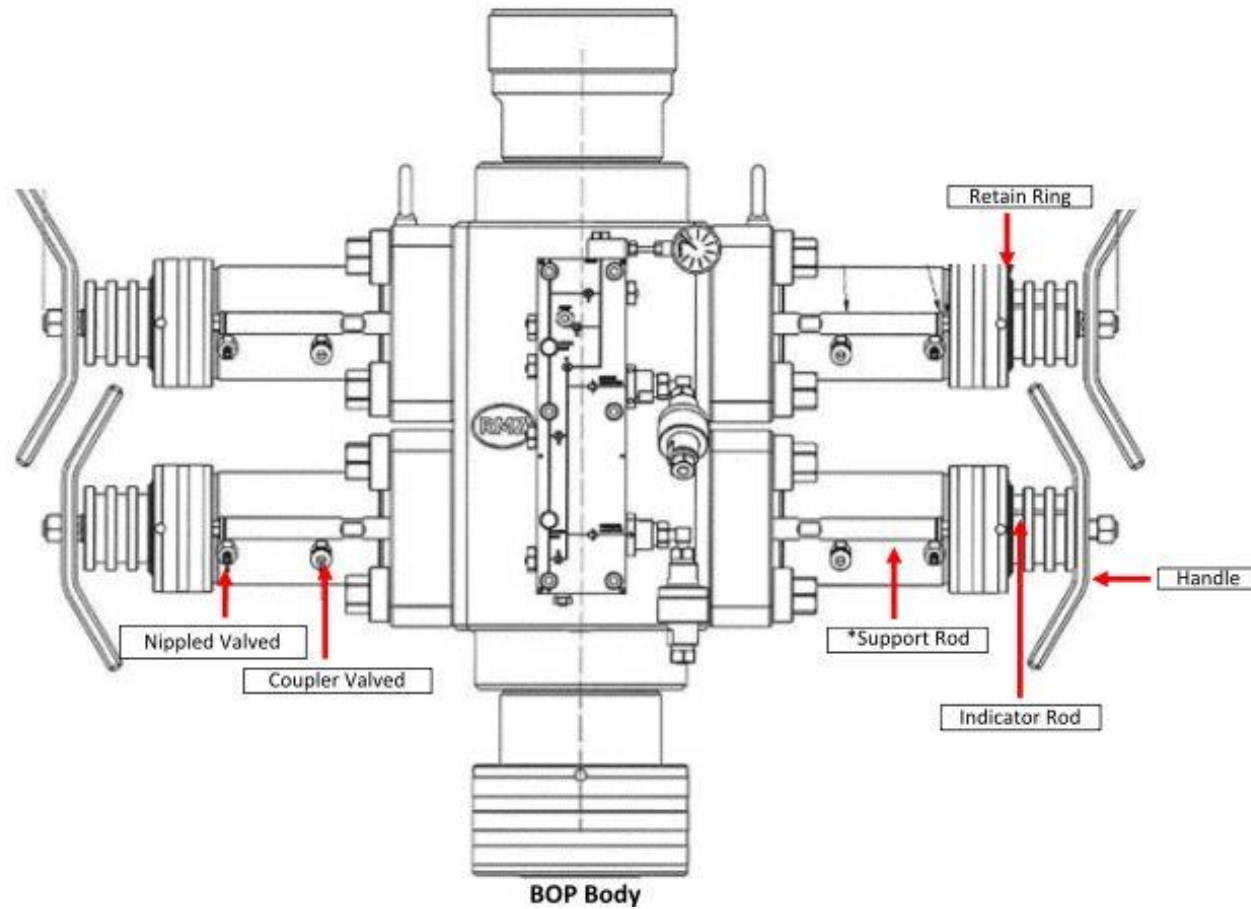

Blow Out Preventer (BOP)



- to allow well control by pumping the fluid below closed BOP
- for fluid sampling/inhibitor injection
- wellhead crossover with different top and bottom unions
- provide large bleed off path for wire

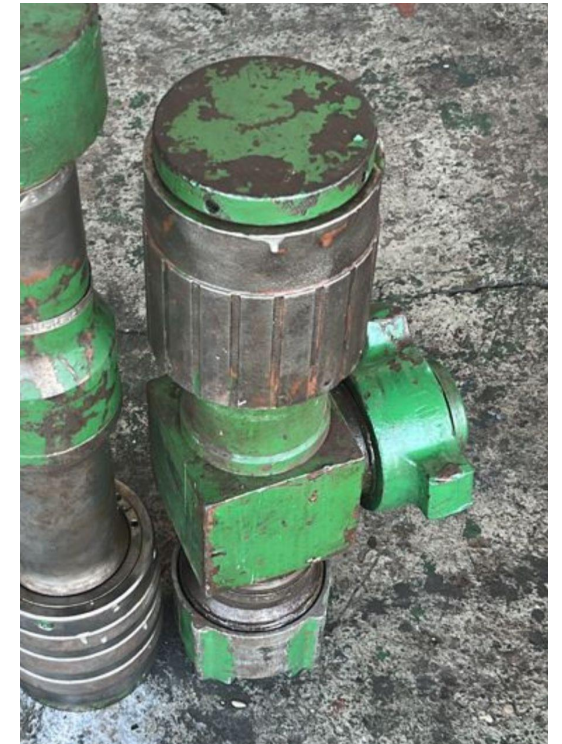

Low Torque Valve

- To control the flow by opening and closing
- Know as plug valve
- Tightening protruding lugs using sledgehammer
- Has one or more horizontal passageways to allow flow through the valve when open
- Eg. FMC Weco 1502 Plug Valve



- To provide transition between different size thread and otherwise incompatible unions made by same or different manufacture
- Design with Union Box Up and Union Pin & Collar Down
- Commonly used is QU to QU type (depends on Xmas tree)

Ball Valve

- To hold pressure from below and above
- While close ball valve, theres a possibility to cut wire
- Manually operate with torque handle
- Can be close and open by hand pump
- WP is 5K psi

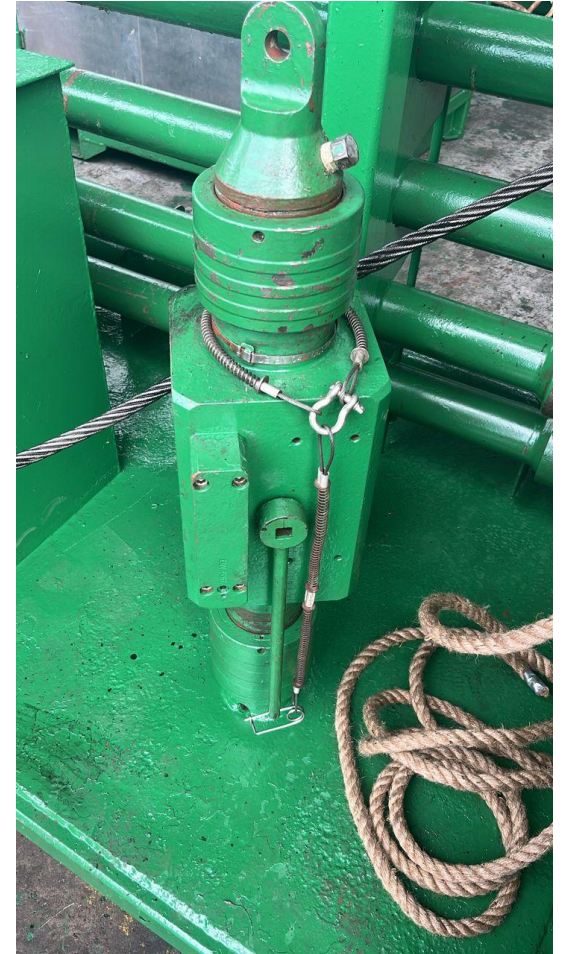

- Used to operate a number of valves
- Types and functions:
 - CP- operate BOP
 - SWCP- operate MV and SCSSV
 - WCP- operate BOP, stuffing box, MV and SCSSV
- Provide hydraulic in high pressure from low air pressure or gas input
- Air supply 75psi-120psi (standard is 100-110psi)
- Hydraulic oil supplied 3K - 5K psi to dual BOP and stuffing box
- Supplied 10K psi to DHSV, MV, test line

Control Panel



Pressure Test Unit (PTU)

- To pump in fluid or pressure PCE equipment
- Has high volume pump for fast filling and high pressure pump for test up to max 15K psi
- Manual lifting
- Suitable with water/soluble oil or glycol
- Test with chart recorder if required



Surface Equipment

- Equipment
 - Powerpack
 - RSU
 - Wireline Mast
 - Hay Pulley
 - Air Compressor

- A single piece configuration, skid mounted with integral crash frame, constructed in carbon steel with single point lifting (JCB 444, 4 cylinder, 84hp, Denison Vane pump for SOP)
- To supply hydraulic power to RSU and WM
- Used diesel to power up engine
 - more reliable than petrol
 - more safety in hydrocarbon area
- Hydraulic, spring starter which powered by diesel
- Open loop (SOP, TIS, NOV Lightline) and closed loop (NOV Flyline)
- Zone 2 rated
- Connection:
 - Holmbury- PP to RSU
 - Snaptite- mostly PCE

- Zone 2 spec

- flame trap
- spark arrestor
- intake valve
- manicooler
- overspeed shutdown
- exhaust
- coolant temp
- low engine oil
- screw in dip stick

- Safety Shutdown

1. overspped shutdown @ 2200RPM
2. low engine oil @ 15psi
3. high coolant temp @ 99deg celsius
4. high exhaust temp @ 200deg celsius

Power Pack



Open loop

Return to sump (atmospheric pressure)
SOP, TIS, NOV Lightline
Good control of line force and speed
Best for fishing

Closed loop

Return to circuit (always pressurized)
NOV Flyline
Better response to speed and direction changes
Best for logging

- Starting Checklist

- check hydraulic tank suction line ball valve fully open
- check hydraulic oil level
- check diesel level
- check engine oil level
- check air inlet/outlet and exhaust
- check engine fan belt and guards
- check exhaust flametrap
- check accumulator pressure > 2500psi
- check all hydraulic quick connector for winch and BOP
- check radiator coolant level

- Starting Procedure
 - keep engine stop cable fully IN
 - keep diesel cut off valve in start position
 - keep winch unit drum directional control valve in neutral
 - start engine by pulling and holding inlet Overspeed shut down valve and depressing foot pedal starter
 - keep continue holding Overspeed shut down valve for 10second until oil pressure in built
 - release foot pedal starter and inlet Overspeed shut down valve

- **During Operation**

- check engine oil pressure
- check radiator coolant for any leakage
- run engine for 5-10mins, before duty
- check coolant and hydraulic oil temperature, not exceed 90* C

- **End of Operation**

- fill diesel tank
- clean the unit
- during transportation keep hydraulic hose on top of skid frame
- cover unit with canvas cover

Reel Skid Unit (RSU)

- To turn the wire drum lower and rise tool string in well
- Also known as wireline unit or winch
- Drum assembly can be single or double
- WP is 2200psi to 2500psi
- Spooling: Tension of wire should be 300lbs to 400lbs
- Available in SOP, TIS, NOV Lightline, NOV Flyline



- **Pre-operational check:**
 - Ensure gear is in NEUTRAL
 - Handbrake is ON
 - Check drive chain tension
- **Parts and basic control**
 - Drum brake- to keep drum stationary
 - Direction lever- to select rotation direction of drum
 - Gear box- to select speed of drum rotation
 - Hydraulic control valve- to control speed of drum rotation
 - Weight indicator- to measure strain on wireline
 - Odometer- to indicate wireline depth

Reel Skid Unit (RSU)

- Counter Wheel Assembly

- an essential component which accurately display depth or wireline tools (in meter and feet)
- consist:
 - counter wheel- in vary size from 8" to 16" diameter (OD wire x 120 = correct pulley)
 - pressure wheel- to prevent wire from springing out of counter wheel
 - wheel unit
 - measuring wheel = 16"
 - right angle drive = 1:2
 - odometer ratio = 1:2



Reel Skid Unit (RSU)

- Odometer/Depth Indicator

- to indicate depth of wireline toolstring hanging in well (feet)
- known as depth counter/depth measuring device
- manually set to zero and start reading from tubing head flench (THF)
- drum rotation:
 - forward- into well & depth increase
 - backward- out of well & depth decrease
- provided with mechanical right angle drive
- right angle drive converts wheel rotation to depth units
- consist counter cable:
 - a cable that connect both odometer and right angle drive at RSU which convert counter wheel rotation to depth units

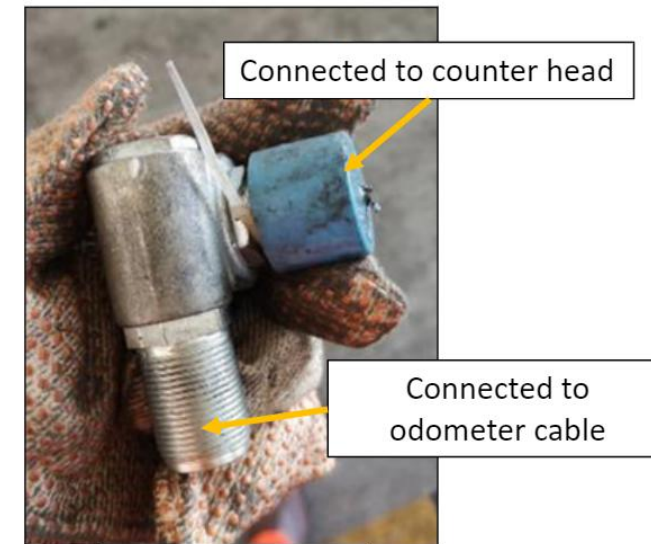

Right Angle Drive

Weight Indicator

- To determine total weight of toolstring hung in tubing
- Martin Decker type, quite positive in showing jar action, fairly accurate reading of weight pulled (slow pull)
- Time lag caused by hydraulic response between load cell and indicator (high speed jarring)
- To get best possible result, completely flush the hose and recharge the unit (once per month)
- Load cell is connected to hay pulley and Xmax tree forming a pull at 90*, each side
- Calibrated in lbs. Available in 2000lbs, 4000lbs, 5000lbs
- If fluid leaks, plated of load cell will close, may cause of incorrect reading

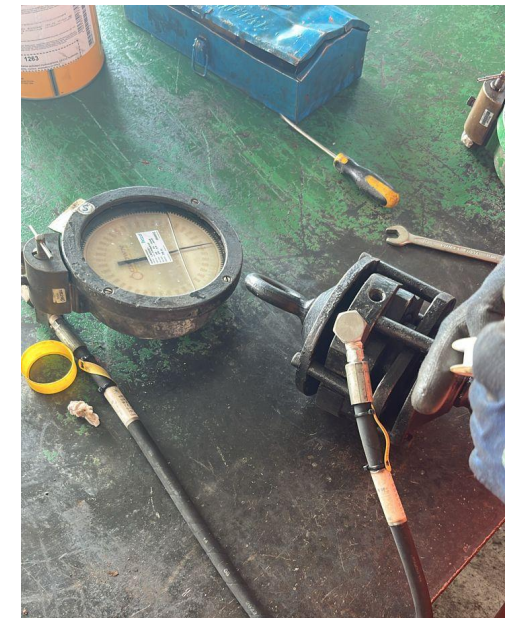

Hay Pulley

- To bring wireline down from stuffing box and into horizontal to the wireline winch drum
- Wire should be parallel to lubricator to reduce side loading and bending stress
- Wire should form a 90 degree angle at the pulley, important to provide accurate reading
- Hole in the frame of hay pulley is to permit a line wiper attachment to be fitted to apply lubricant corrosion inhibitor
- To clean the wire of corrosive well completion fluids, increase lifetime of wire

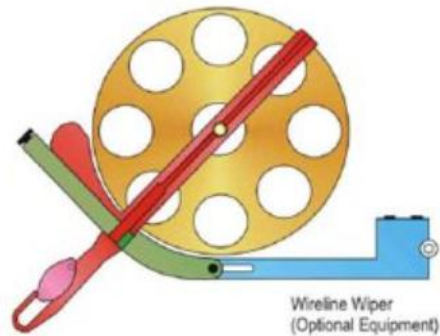

Wireline Mast

- To hold and lift lubricator from horizontal to vertical conditon during operation
- Height available in 30ft, 40ft and 70ft mast
- Powered by powerpack via hydraulic hose
- 70ft mast is zone 1, meanwhile 40ft and 30ft mast is no zone
- Capability of weight for 40ft (1.5ton) while 70ft (2ton)
- Always use 4 guide wires to secure mast
- WM used when theres no gin pole or crane
- Consist:

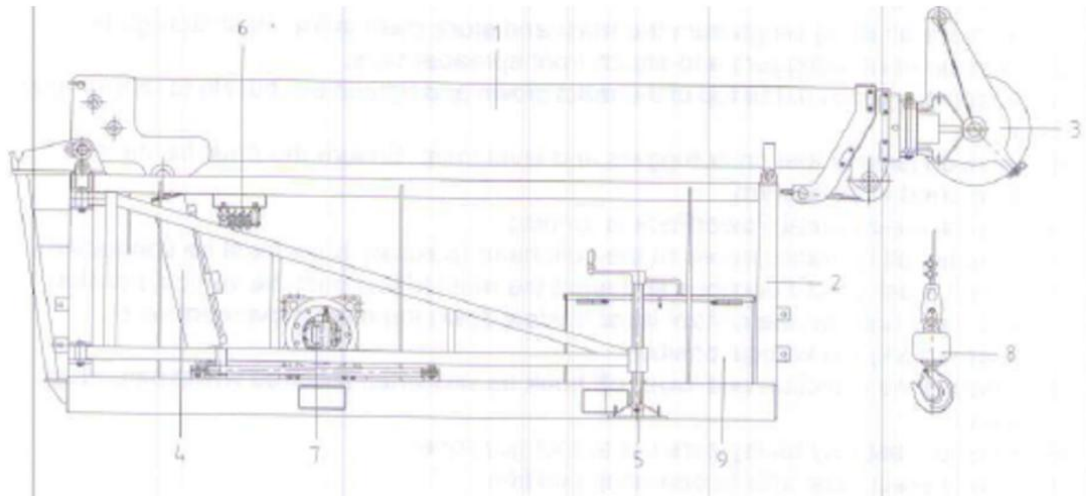

1. Mast
2. Frame
3. Sheave
4. Lifting cylinder
5. Outrigger
6. Control levers
7. Winch
8. Hook
9. Storage box



- Operating procedure consist:
 - erecting
 - lowering
 - hook hoisting/lowering
 - mast telescoping
 - mast topping

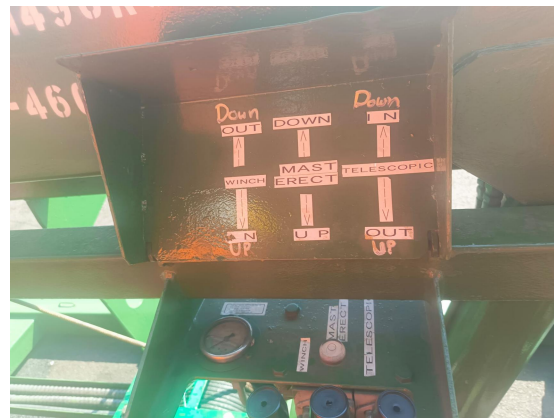

- K-Winch Mast 70ft (Zone 1)
 - Elmar Zone 1 Lightweight Wireline Mast is a compact, lightweight and heavy duty unit capable of operating in wind gusts of up to 60mph
 - Height from 27ft (8.23m) to 70ft (21.3m)
 - Hydraulically operated mast sections are easily erected by 2 men approx. 15mins
 - Load Safe Working load rating 20000lbs (9072kgf)
 - Features and benefits:
 - sheaves provided for running wireline over horse head
 - lower sheave fixed to mast frame
 - fully erected in 15mins
 - rated for use in 60mph wind
 - ATEX approved for use in Cat 2 (Zone 1) hazardous area

Downhole Equipment

Basic Toolstring

- Wireline toolstring is an assembly that run downhole to perform specific operation
- Toolstring operation manipulated by upward and downward movement of wire, operated by WM
- Toolstring configuration depends on each difference operation

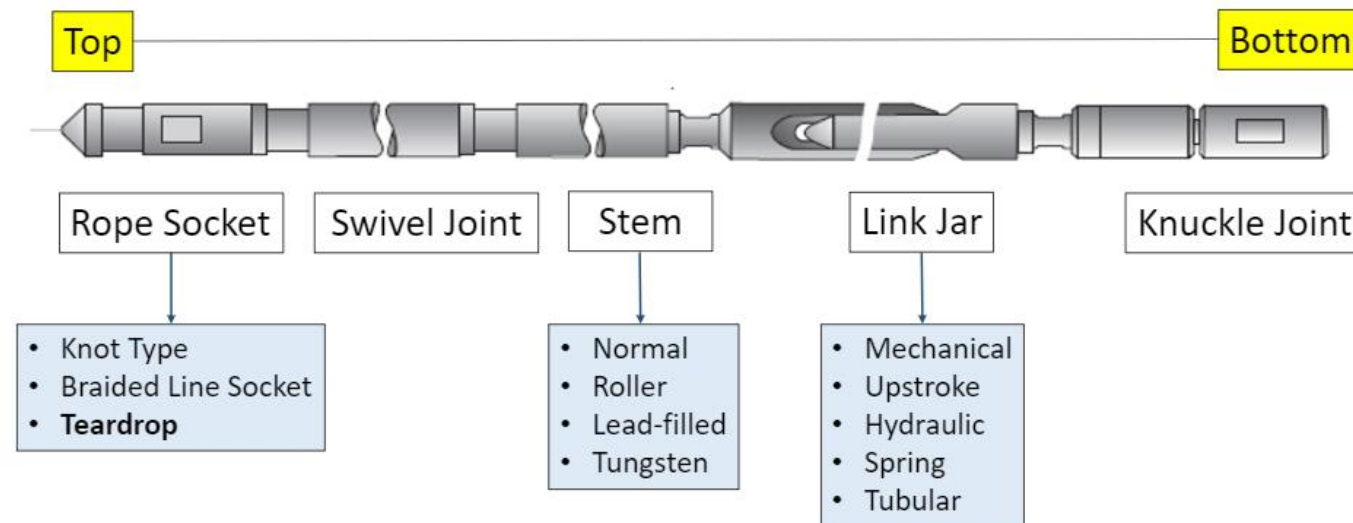

DHT Connection

Sucker Rod Thread (in.)	QLS (in.)
15/16	1.1/2
1.1/16	1.7/8
1.9/16	2.1/2

Shear Pin Sized (in.)
1/8
3/16
1/4
5/16
3/8

Types of Shear Pin
Brass
Stainless Steel
Aluminium

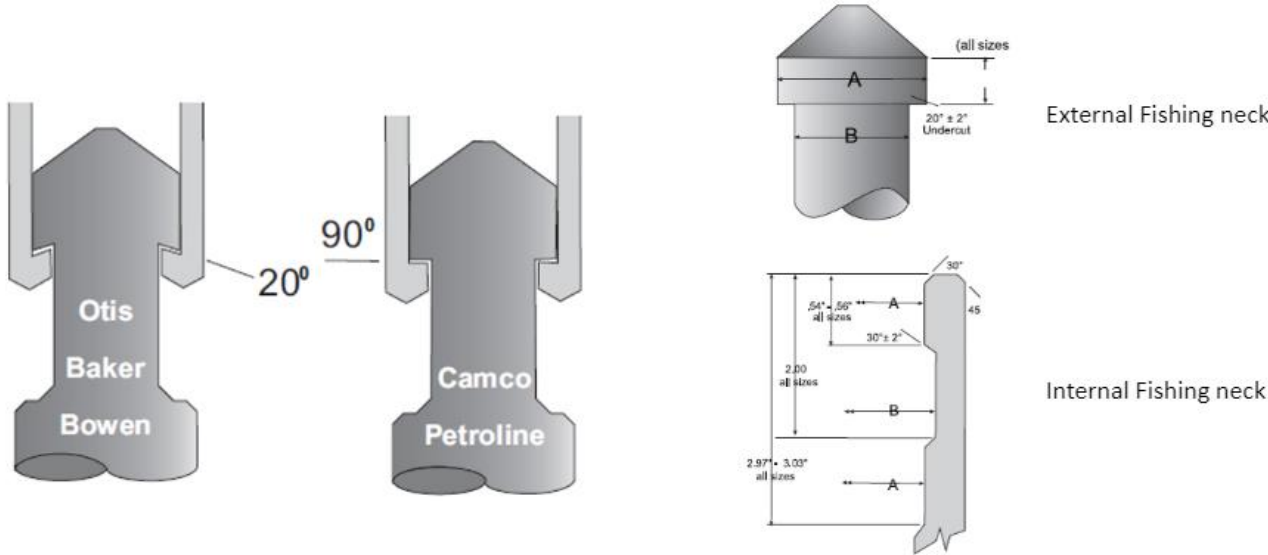

Sucker Rod Thread (SRT)

- Standard slickline tool connection
- Connection of Pin and Box
- Can be damaged from:
 - direct damage in toolbox
 - corrosion if not protected
 - overthightening
- 10 TPI (eg. 15/16" - 10 SRT)



Quick Connect

- To connect tool without using wrenches
- Easier make-up and break out without using pipe wrenches
- Connection consist of Male(pin) and Female(box)
- Available type: QLS, HD-QRJ, Trinity
- Advantages
 - Speed of assembly
 - Easy changing tool
 - Higher strength than SRT
 - No needed pipe wrenches
- Consist of 4 part:
 - QLS Female
 - QLS Male
 - Coil Spring
 - Locking Slip



QLS Female

Size (in)	Fishneck OD (in)	Pin Connection (in)
1.1/2	1.375	15/16
1.7/8	1.750	1.1/16
2.1/2	2.313	1.9/16

QLS Male

Size (in)	Fishneck OD (in)	Pin Connection (in)
1.1/2	1.375	15/16
1.7/8	1.750	1.1/16
2.1/2	2.313	1.9/16

Rope Socket

- Uppermost component to form an essential link between toolstring and wire
- Teardrop type (common in DB)
- External fishing neck, thimble eye (brass), thimble sleeve, grub screw
- More conventional RS (Teardrop)

OD (in)	Fishneck (in)	Bottom Connection (in)
1.250	1.187	15/16
1.500	1.375	15/16
1.875	1.750	1.1/16
2.125	1.750	1.9/16
2.500	2.313	1.9/16



- To minimize the effect of wire twisting
- Essential to use swivel between RS and stem is to prevent twisting of wire in following toolstring
- Has a bearing that built-in which used to minimize the rotation of toolstring while in well
- Has double fishing neck and standard pin and box threads
- Differences between swivel joint and knuckle joint is sideways angle and swivels have bearing for rotation
- Consist of 6 parts:
 - Upper body
 - Nut
 - Roll pin
 - Lower body
 - Shaft
 - Bearing

Swivel Joint

OD (in)	Fishneck (in)	Bottom Connection (in)
1.250	1.187	15/16
1.500	1.375	15/16
1.750	1.375	1.1/16
1.875	1.750	1.1/16
2.125	1.750	1.1/16
2.500	2.313	1.9/16

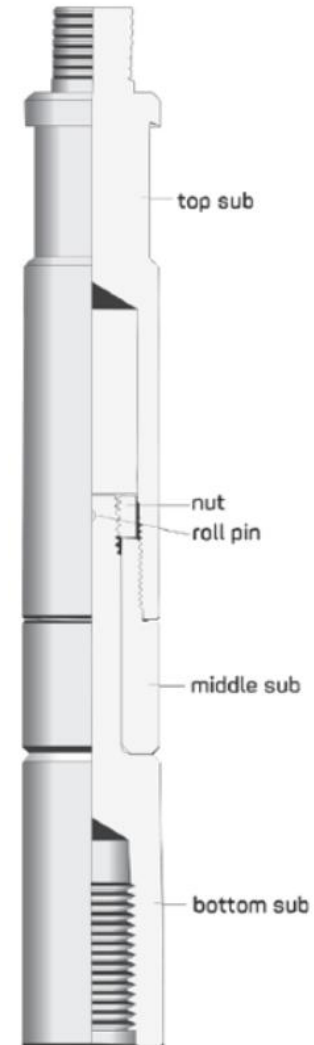

- To provide additional weight to increase impact force delivered by jars
- Known as Sinker Bar/Weight Bar
- Available in 2ft, 3ft and 5ft
- Has pin and box
- Useful with hydraulic jar
- Other types of stem:
 - Roller stem (for deviated well)
 - Lead-filled (no heavy jarring action)
 - Tungsten stem (higher density)



Normal Stem - OD sizes

O.D.	Fishneck O.D.	Connections	Weight	Length
1.250"	1.187"	15/16UN	8lbs	2ft
1.250"	1.187"	15/16UN	12lbs	3ft
1.250"	1.187"	15/16UN	20.5lbs	5ft
1.500"	1.375"	15/16UN	12lbs	2ft
1.500"	1.375"	15/16UN	18lbs	3ft
1.500"	1.375"	15/16UN	30lbs	5ft
1.875"	1.750"	1 1/16UN	19lbs	2ft
1.875"	1.750"	1 1/16UN	28.5lbs	3ft
1.875"	1.750"	1 1/16UN	47.5lbs	5ft
2.125"	1.750"	1 1/16UN	24lbs	2ft
2.125"	1.750"	1 1/16UN	36lbs	3ft
2.125"	1.750"	1 1/16UN	69lbs	5ft
2.500"	2.313"	1 9/16UN	34lbs	2ft
2.500"	2.313"	1 9/16UN	50lbs	3ft
2.500"	2.313"	1 9/16UN	83lbs	5ft

Roller Stem

- Has same weight and mass as normal stem
- Designed to reduce friction againsts tubing wall in deviated wells, or in wells with paraffin, asphaltene, etc
- Allow to roll down the tubing wall and cut down the friction when using normal stem
- Rollers should be inspected for free rotation before operation
- Consist of 3 parts:
 - Body
 - Roller
 - Pin
- Available in 3ft and 5ft



OD (in)	FN (in)	Roller size (in)
1.1/4	1.187	1.625
1.1/2	1.375	1.975
1.7/8	1.750	2.500

- Provide greater mass for same diameter and length of normal stem
- Has regular steel pin and box connections and tubular steel outer barrel. Inside is filled with lead to provide greater weight
- Should not be used in heavy jarring operation which leads will creep downward and split the outer barrel

- Higher density of heavy weight stem
- Consist of a tube which carries the tungsten inserts and a bottom sub with box connection
- Used instead of normal stem to provide kinetic energy to assist upward and downward jarring impact in higher pressure applications
- Should not be used in heavy jarring operations

Differences of Stem Appearance



Normal Stem

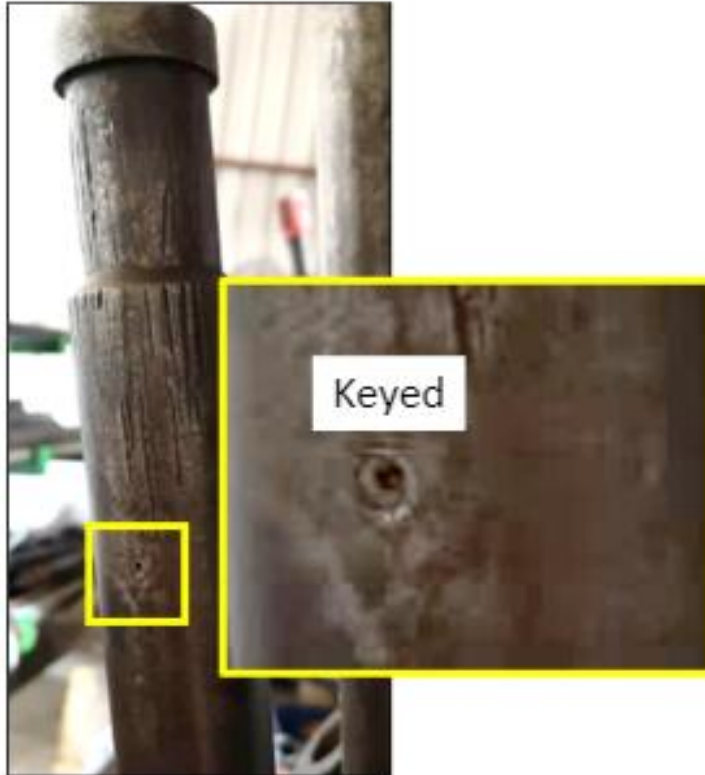

Lead-filled Stem



Tungsten Stem

Mechanical Jar

- To deliver effective jarring down or up impacts
- Used because it is mechanically simple, low maintenance and used for both jarring actions
- 2 pieces are linked together which are free to be extended and collapsed
- 2 length of jar stroke in closed position:
 - for 20inc jar known as 20 stroke
 - for 30inc jar known as 30 stroke
- Effectiveness of the impact:
 - weight of stem used
 - length of stroke jars
 - size and straightness of tubing

OD (in)	FN OD (in)	Bottom Connection (in)	Stroke (in)
1.250	1.187	15/16	20/30
1.500	1.375	15/16	20/30
1.875	1.750	1.1/16	20/30
2.125	1.750	1.1/16	20/30



- Used for jarring up
- Has a ball locking mechanism and a compression spring tension
- Piston mandrel is unlocked as compression force of spring is exceeded, produce upward impact
- Jarring is brought about by pulling on wireline, without acceleration
- Advantages of upstroke jar over hydraulic jar are that they are fully mechanical and have no seals, enabling to be used in gas wells
- Springs tension is:
 - 400lbs
 - 700lbs
 - 1000lbs

Upstroke Jar



Operation:

1. Line overpull will compress lower spring against the balls.
2. As ball gage moves upwards, balls move out into the groove.
3. Link rod releases and accelerates upwards to create the impact.
4. Stem weight resets jars as balls retract into space above internal ring.

- Used in same condition to spring jar when mechanical jar have been unsuccessful
- Always include link jar to provide downward jar to shear off in necessary
- For jar up only
- Advantage is the jarring force is adjustable, since it is determined by the initial pull on wire
- Hydraulic oil- 10-W-30 / Tellus 32 / Silicone Oil
- Jar should be operate in 30seconds to 2minutes of pull
- In gas well, hydraulic oil can be contaminated, reduce jarring efficiency and jar closing
- Never place hydraulic jar below link jar, can act as shock absorber

Hydraulic Jar

- Always CLOSE the jar as toolstring is lowered from lubricator before laying down
- Failure to do so:
 - Bent / cracked piston shaft
 - Piston shaft exposed to corrosion or damage
- Operation
 - Jars in closed starting position
 - Line tension being applied
 - Rapid upward motion creates upward impact
 - Stem weight closes the jar

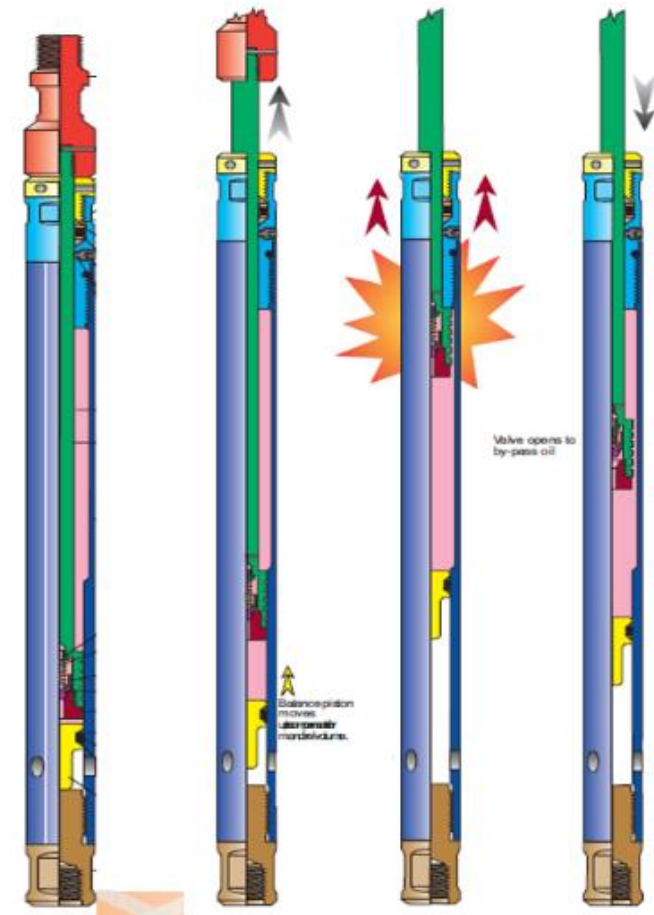

- To provide upward impact force
- Used in same condition to hydraulic jar
- Used in deviated wells when wire speed is insufficient
- Used to jar up and gas wells compared to hydraulic jar
- More durable than hydraulic jar as their are purely mechanical
- Impact force of jar detemined by selection or determined of mechanism
- Advantages of spring jar
 - No O-ring seals to leak and allow internal pressure build-up
 - Fluid bypass permits free access of well fluids through the jars
 - Generally greater upward impact than comparable hydraulic jars

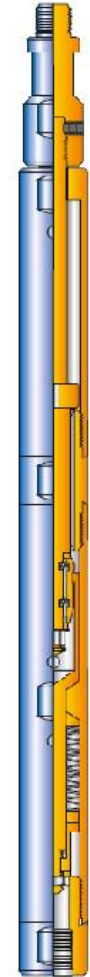

SPRING
JAR

- To check the trip point and correct function of spring jar
- Apply hydraulic pressure to trip the jar and note the trip point indicated as a hydraulic pressure
- This pressure is converted to lbs of jar pull

<u>Jar Pull (lbs)</u>	<u>Gauge Pressure (psi)</u>
500	610
600	705
700	800
800	895
900	990
1000	1085
1100	1180
1200	1275
1300	1370
1400	1465
1500	1560



Tubular Jar

- Used for fishing operation
- By manipulating the wireline, jarring forces can be delivered in both upward and downward
- Jar rod is completely enclosed
- Effectiveness of impact depends on weight of stems and length of stroke jar
- Mostly used jarring in debris in tubing
- Jar is tubular and tube is perforated for fluid bypass
- Recommended to place directly below wireline stem



Knuckle Joint

- To add flexibility to toolstring and used in deviated well
- Consist if two bodies which are connected to each other by ball and stem, and external fishing neck at top sub
- Permits 15* of sideways movement and should be used when necessary
- Ball and socket of knuckle provide rotation and angular deviation of tool. Seals in ball provide sealing capability
- Also used at fishing operations to give flexibility between fishing tool and jar, aid in latching

- Consists of 5 parts:

- Fishing neck
- Upper body
- Ball pin
- Roll pin
- Lower body

O.D. (in.)	Fishneck O.D. (in.)	Connections Box & Pin
1.000	0.875	5/8
1.250	1.187	15/16
1.500	1.375	15/16
1.875	1.750	1.1/16
2.125	1.750	1.1/16
2.500	2.313	1.1/16
2.500	2.313	1.9/16

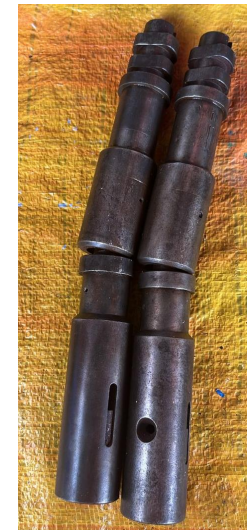

- Allow angular movement in deviated wells and when light jarring required
- Can be run with pressure/temperature gauges in conjunction with a shock absorber
- Due to its construction, it will always be a weak point in the toolstring and therefore its use should be kept minimum
- Not recommended for fishing, but used only to latch toolstring that already has jarring facility

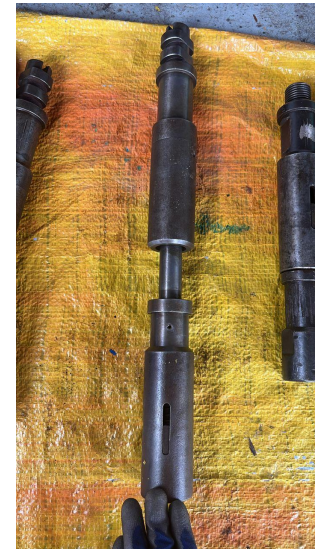

- To reduce the shock loading at RS and causes stem to “accelerate” faster when Spring/Hydraulic Jar go off
- Known as Stretch Simulators
- Usually used above Spring/Hydraulic Jar
- Installed in toolstring below RS when Spring/Hydraulic Jar are used at shallow depth (<300m)
- It is good practice to use at all time, but makes toolstring assembly complicated

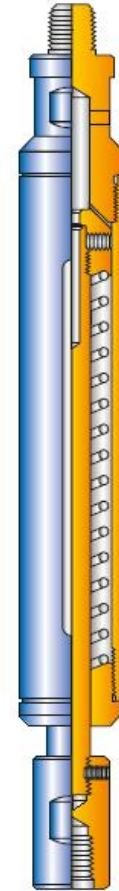

WIRELINE
ACCELERATOR

- Lift and support toolstring off the low side of the well
- Large rollers reduce friction, making it easier to convey toolstring to working depth
- Type available:
 - Roller bogie slickline cased hole
 - Roller bogie E-line cased hole
 - Roller bogie E-line open hole
- Roller bogie and toolstring section should be as rigid as possible to avoid grounding on tubing wall or other obstruction
- If knuckle in toolstring, roller bogie must be positioned below and above knuckle



Slickline VariBall

- Provides efficient and effective downhole roller chasis for high angle wells
- Minimizes frictional toolstring drag, minimizes roller contact and self-aligns during deployment
- Important when running in plastic and ceramic coated tubing
- Offer flexibility and adaptability
- Easily interchangeable roller sizes

Slickline VariBall™ Roller System

VariBall. Go **Further**. Go **Faster**.



Tubing Drift

- Drift runs are mandatory for TCC
- There is hole below tool which permits pressure/fluid bypass
- Functions:
 - check tubing is clear and accessible
 - establish hold-up depth (HUD) inside tubing
 - establish liquid level in tubing
 - establish tight spots and resistance in tubing
 - check condition of wireline in use
 - check condition and function of measuring head assembly
 - check proper working of depth counter
 - check efficiency of RSU
 - check presence of wax/scale/sand in tubing

2.3/8"	2.7/8"	3.1/2"
1.867"	2.441"	2.867" (above TR)
	2.302"	2.735" (below TR)

Drift size 2.302" can be used at tubing 2.7/8" and 2.3/8"



Gauge Cutter

- To check tubing ID, tag total depth, locate the nipple ID and No-Go, cut sand, scale, paraffin from tubing well
- Can be used to run in hole before running toolstring
- Known as Tubing Gauge/Gauge Ring
- Designed with open space in body to allow fluid bypass
- Has no moving parts



OD (in)	FN OD (in)	Pin (in)
1.25 - 1.50	1.187	15/16
1.50 - 2.00	1.375	15/16
2.00 - 2.50	1.375	15/16
2.50 - 3.00	1.750	1.1/16

Wire Scratcher

- To clear wax, scale and sand in well, nipple profiles, SSD sleeves and SPM
- Commonly made from an old piece of stem and sucker rod drilled and tapped
- Size if tool can be altered, depends on length of wire used
- Advantages- used at fishing to dislodge scale, sand, paraffin etc
- Disadvantages- have no sheer off and time consuming when redress

OD (in)	FN OD (in)	Pin (in)
1.000	1.375	15/16
1.500	1.375	15/16
1.875	1.750	1.1/16
2.125	1.750	1.1/16

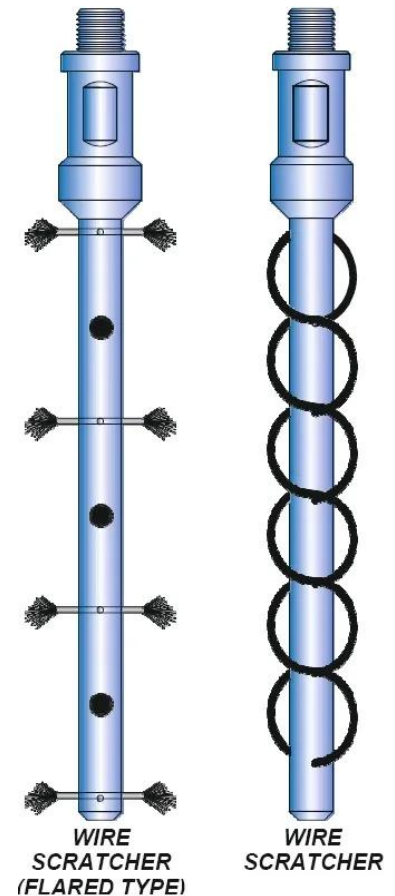

Lead Impression Block

- Known as 'bottom-hole camera'
- Used during fishing to check shape or size of top of fish
- Similar in appearance to blink box, but it is filled with lead
- During operation, LIB will be run down in hole and will be jarred downward once to capture the situation downhole

OD (in)	FN OD (in)	Bottom connection (in)
1.25 - 1.50	1.187	15/16
1.50 - 2.00	1.375	15/16
2.00 - 2.50	1.375	15/16
2.50 - 3.00	1.750	1.1/16

OD (in)	Tubing Size (in)
1.23	1.1/4
1.86	2
2.25	2.5
2.62	3
2.81	3



Fluted Centralizer

- Used in deviated wells to ensure toolstring remains in centralized position
- Normally attached to toolstring just above the running/pulling or fishing tool
- OD is constructed to suit ID of tubing
- Can be used as drift

OD (in)	FN OD (in)	Bottom connection (in)
1.50 - 2.50	1.375	15/16
2.50 - 3.50	1.750	1.1/16
3.50 - 4.50	2.313	1.9/16



- Used when heavy downward jarring is required to dislodge a fish, or push something down the hole
- Act as “Cutter Bar”, cut wire at top of RS of toolstring cannot be retrieved

OD (in)	FN OD (in)	Bottom connection (in)
1.25 - 1.50	1.187	15/16
1.50 - 2.00	1.375	15/16
2.00 - 2.50	1.375	15/16

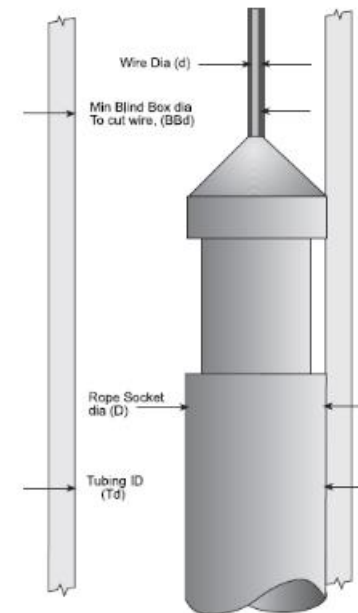

As a “Cutter Bar”

- Worst possible case, toolstring laying against one wall of tubing.
- Blind box diameter should be large enough to prevent the blind box from passing down slide of toolstring.



BLIND BOX

Tubing Swage

- To restore light collapse in tubing and remove large obstructions
- Recommend to run with hydraulic/spring jar
- Has fluid bypass hole permits the passage of fluid when OD of swage fills the tubing ID
- Have no moving parts which required little maintenance but have no sheer pin can make it stuck in restrictions

OD (in)	FN OD (in)	Bottom connection (in)
1.25 - 1.50	1.187	15/16
1.51 - 2.50	1.375	15/16
2.51 - 3.00	1.750	1.1/16
3.01 - 5.00	2.313	1.1/16

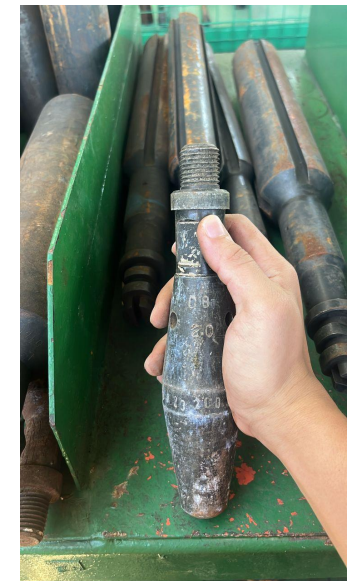
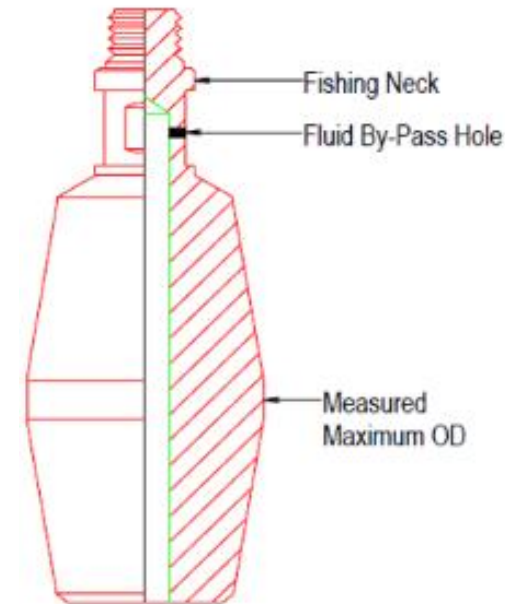

Tubing Broach

- To remove burrs and build up within the well bore and remove scale and rust from tubing internal diameter
- It is good practice to include hydraulic jar in toolstring
- Available types:
 - Diamond cut broach
 - Straight cut broach
 - Center cut broach

OD (in)	FN OD (in)	Bottom connection (in)
1.50 - 2.50	1.375	15/16
2.51 - 4.00	1.750	1.1/16
4.01 - 5.00	2.313	1.1/16
5.01 - 6.00	3.125	1.9/16



Check Set Tool

- To check that X, XN, R and RN lock mandrel has been set correctly in tubing nipple
- Available in different lock mandrel sizes
- Available types:
 - Shear pin check set tool
 - Collar check set tool



**X CHECK
SET TOOL**

“R” Series Pulling Tool

- To engage fishing neck, and jar up to shear pin/release
- “R” is defined as ring
- Three type available “RB,RS and RJ”
- Difference is in length of core
 - RB - longest core
 - RS - immediate length core
 - RJ - shortest core
- Reach determined by length of core
 - Longest core - short reach
 - Shortest core - long core



	Part #	Size (ins)	OD (ins)	Fish Neck	Will Latch	Top Thread	Shear Pin (ins)	Reach (ins)
RB	40RB14	1 1/2	1.430	1.187"	1.187"	15/16 - 10	1/4	1.265
	40RB1	2	1.770	1.375"	1.375"	15/16 - 10	5/16	1.219
	40RB18	2 1/2	2.180	1.375"	1.750"	15/16 - 10	5/16	1.203
	40RB19	3	2.740	2.313"	2.313"	1 1/16 - 10	3/8	1.297
RS	40RS5	1 1/2	1.430	1.187"	1.187"	15/16 - 10	1/4	1.797
	40RS6	2	1.770	1.375"	1.375"	15/16 - 10	5/16	1.984
	40RS7	2 1/2	2.180	1.375"	1.750"	15/16 - 10	5/16	1.984
	40RS9	3	2.740	2.313"	2.313"	1 1/16 - 10	3/8	1.190

“S” Series Pulling Tool

- To engage external fishing neck, and jar down to shear/release
- “S” defined as Sleeve
- Available type is SB, SS and SM
- Difference is length of core:
 - SB - longest core
 - SS - middle core
 - SSJ - shortest



	Part #	Size (ins)	OD (ins)	Fish Neck	Will Latch	Top Thread	Shear Pin (ins)	Reach (ins)
SB	40SB6	1 1/2	1.437	1.187"	1.187"	1 5/16 - 10	3/16	1.297
	40SB1	2	1.766	1.375"	1.375"	1 5/16 - 10	1/4	1.219
	40SB2	2 1/2	2.188	1.375"	1.750"	1 5/16 - 10	1/4	1.281
	40SB9	3	2.734	2.313"	2.313"	1 1/2 - 10	5/16	1.380
SS	40SS3	1 1/2	1.430	1.187"	1.187"	1 5/16 - 10	3/16	1.780
	40SS1	2	1.770	1.375"	1.375"	1 5/16 - 10	1/4	2.030
	40SS2	2 1/2	2.180	1.375"	1.750"	1 5/16 - 10	1/4	2.000
	40SS4	3	2.840	2.313"	2.313"	1 1/2 - 10	5/16	2.210
* SM	40SM7	1.66	1.187	0.875"	0.875"	1 5/16 - 10	3/16	1.680



- Is a standard Camco Jar Up to shear and release tool
- JU series differ by length of core

Core	JU Assembly	Reach	Core Length	Otis Core Equivalent*
'C'	JUC	Short	Long	'B'
'S'	JUS	Medium	Intermediate	'S'
'J'	JUL	Long	Short	'J'



- Is a standard Camco Jar Down to shear and release tool
- JD type differs by length of core

Core	JD Assembly	Reach	Core Length	Otis Core Equivalent*
'C'	JDC	Short	Long	'B'
'S'	JDS	Medium	Intermediate	'S'
'J'	-	Long	Short	'J'



GS Pulling Tool

- To latch internal fishing neck, to shear/release by jarring down
- Available in 2 types:
 - GS pulling tool
 - GSL pulling tool
- GSL mostly used with bigger and stronger prong
 - pulling out FXE safety valve

Nominal Size (ins)	Lock OD Reference	Will Latch ID (ins)	Maximum OD (ins)	Top Thread	Tool Fish Neck (ins)
2	1.875"	1.38	1.81	15/16" - 10	1.375
2 1/2	2.313"	1.81	2.25	15/16" - 10	1.750
3	2.750"	2.31	2.72	1 1/16" - 10	2.313
5	4.562"	4.00	4.50	1 1/16" - 10	3.125

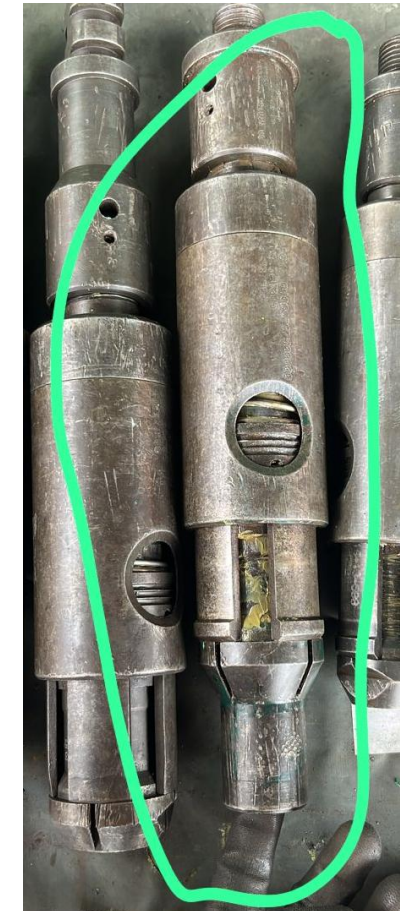

GR Pulling Tool

- To latch internal fishing neck, to shear/release by jarring upward
- Combination of GS and GU adapter
- Pin must be removed from GS
- GU adapter is to convert a standard GS, into GR which jar up to shear

Nominal Size (ins)	Lock OD Reference	Will Latch ID (ins)	Maximum OD (ins)	Top Thread	Tool Fish Neck (ins)
2	1.875"	1.38	1.81	15/16" - 10	1.375
2 1/2	2.313"	1.81	2.25	15/16" - 10	1.750
3	2.750"	2.31	2.72	1 1/16" - 10	2.313
5	4.562"	4.00	4.50	1 1/16" - 10	3.125



PCE Heavy Duty Pulling Tool

- To increase contact area against external fishing neck, jar down to release
- Reduce chances of damaged fishing neck
- Core designed to permit latching of fishing neck with or w/o thread
- Can be used with KOT to retrieve GLV from SPM



Conventional Pulling Tool
50 % Contact Area



Heavy Duty Pulling Tool
95 % Contact Area



“X” Running Tool

- Used to run/set type X and XN lock mandrel
- Run in two position:
 - Selective position - used when setting in any profile except a top one or no-go (XN) profile
 - Non- selective position - used when setting the lock at top profile or no-go (XN) profile
- JAR DOWN to shear TOP pin and JAR UP to shear BOTTOM pin

Selective Position	
Lock Mandrel	<ul style="list-style-type: none">• Keys are FULLY RETRACTED – with running tool holding the lock fully EXTENDED
Running Tool	<ul style="list-style-type: none">• Nipple locator dogs OUT• Lug segments LOCKING the core to the main mandrel• No GAP between the fishing neck and spring housing
Non-selective Position	
Lock Mandrel	<ul style="list-style-type: none">• Keys are SPRUNG forward to permit the 90° shoulder to locate in the nipple
Running Tool	<ul style="list-style-type: none">• Nipple locator dogs IN - now holding the inner mandrel in the ‘up’ position• Lug segments FREE to permit the core to move when the top pin shears• GAP between the fishing neck and spring housing

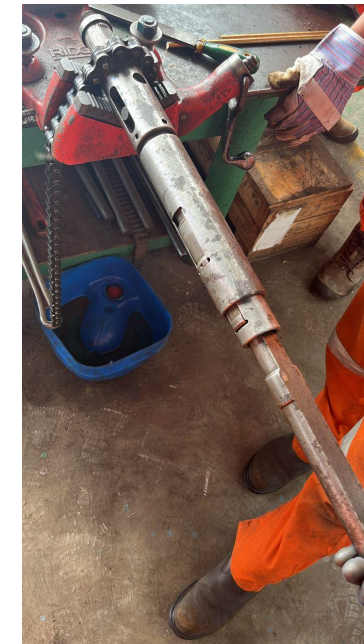
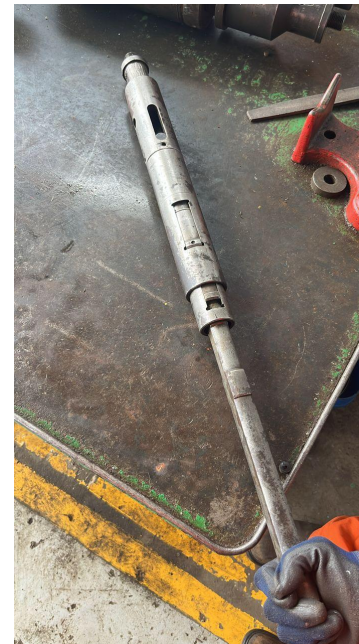

“R” Running Tool

- Developed as high pressure variation of X/XN system
- Nominal pressure rating 20K psi R/RN locks
- Difference between ‘X’ line:
 - dog
 - dog retainer
 - core
- Used to run type R and RN lock mandrel in:
 - Selective position - to run ‘R’ lock at any profile
 - Non-selective position - to run ‘R’ lock into top profile or an ‘RN’ lock

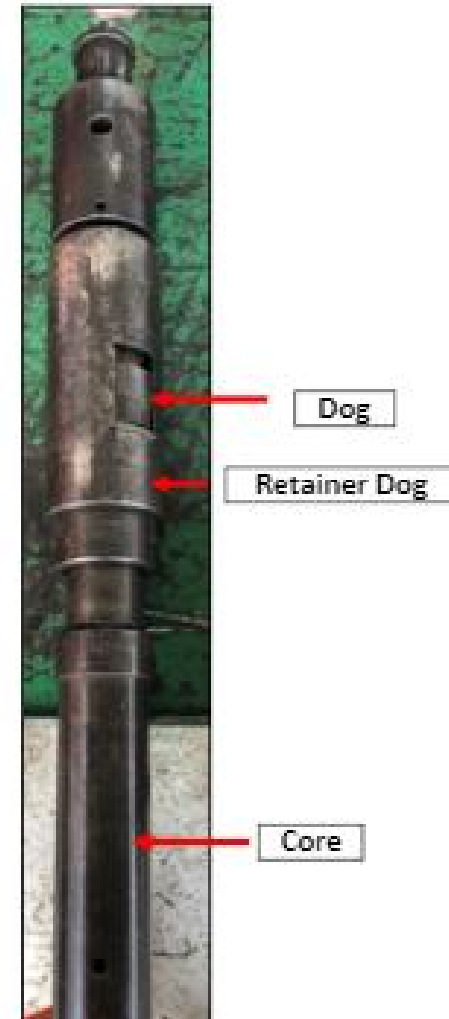

QXD Running Tool

- Used to run QXD lock or uniset lock with Camco B7 safe
- Pulling lock by GS pulling tool with appropriate prong

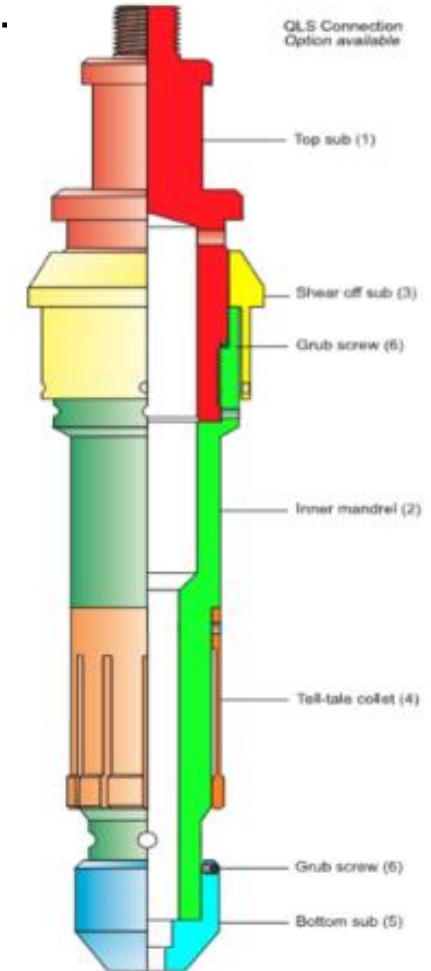

- Similar to QXT but with XT seal
- Used in larger profile
- Specifically for use in tubing hanger profile and run uniset QXT tubing hanger series of lock mandrel or Camco WRDP-2 safety valve

42 BO Shifting Tool

- To engage inner sleeve of SSD before shifting to open or close SSD
- Has 2 pin connection
- Can be inverted
- Run on a standard set of toolstring
- Jar down or jar up
- If pin not sheared, SSD is open

	With the 90° shoulder on keys facing DOWN	With the 90° shoulder on keys facing UP
XO SSD	Opens	Closes



1 42 BO Shifting Tool

- To selectively open XO and XD SSD by passing through the upper sleeve
- Should never be inverted
- Jar down only
- Designed for multiple SSD devices of same size
- No pin to shear and automatically release itself
- Run in two position:
 - Selective - shifting with selected SSD
 - Non-selective - shifting top of SSD

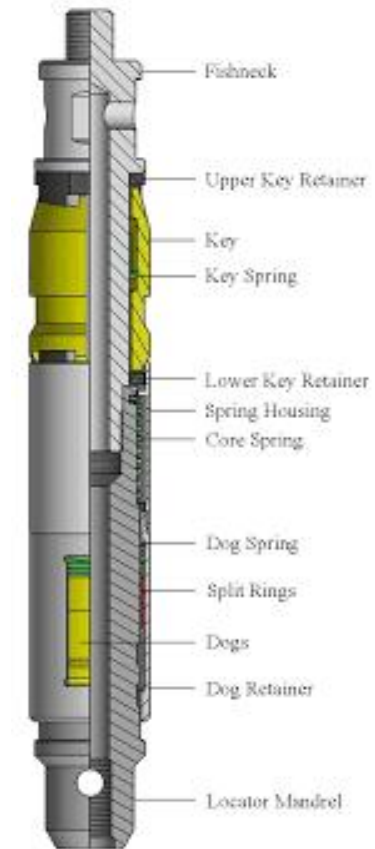

“X” Shifting Tool

- To selectively open or close “X” or “A” SSD
- Can be shifted in any desire sequences
- Jar up and jar down



- Known as Split Skirt Wire Finder
- To locate and ball the upper end of broken wire
- Locate top of wire and direct it inside wire finder
- Jar down will ball the broken wire in wellbore

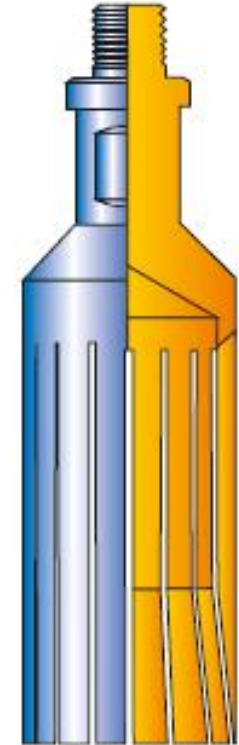

**WIRELINE
WIRE
FINDER**

Wireline Retriever

- Has a flexible spring steel skirt
- Finger of skirt can be flexed gently to a 'snug' fit in tubing
- Some limitation:
 - if wire below nipple, dont jar down against nipple ID which possible to bend or break the finger of skirt
 - can be difficult to successfully pass a nipple
 - if wire is expected/calculated to be below nipple, this tool should be considered

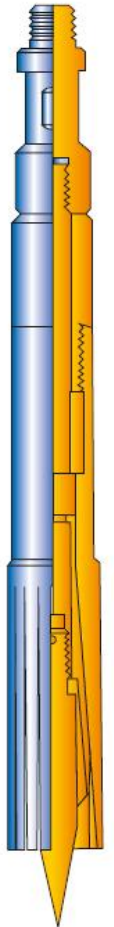

WIRELINE
RETRIEVER

- To retrieve broken wire in wellbore after 'ball' with a wire finder
- Has two or three prong
- Failure to located and balled wire will:
 - causes the wire grab to miss the top of wire and bypass several feet before engaging
 - once this happens, wire will tend to 'stack' around the grab and will foul the grab to extend and cannot be retrieved



- Used to grab downhole tools when:
 - fishing neck is worn or broken
 - there's no fishing neck
 - when larger upward force is required
 - upward jarring only is required
- Available in Releasable type
- Consist set of hardened steel slips, with sharp upward facing teeth to grip fish

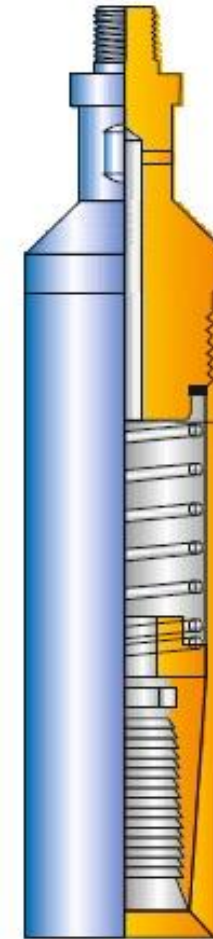

**WIRELINE
OVERSHOT**

- Used to magnetically attract and retrieve ferrous debris lost in wellbore
- Outer sleeve is manufactured from non-magnetic stainless steel
- This focus magnetic flux downwards and guarantees effortless conveyance in well

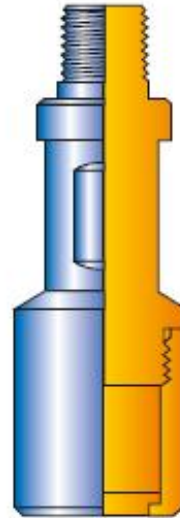

**WIRELINE FISHING
MAGNET**

Alligator Grab

- To retrieve wire and loose debris or junk from the well at depth and deviated well
- Requires a small pin to be sheared before it can active
- Jar down will shear a pin will allow two jaws to snap closes and caught an object
- Grip of jaws can be adjusted by manipulating the compression ring



ALLIGATOR
GRAB

Wireline Center Spear

- To retrieve broken wireline from wellbore after making a small ball
- Used when wire is balled up so badly where 2/3 prong wire grab are impossible to get hold.
- Not recommended for general wire fishing due to:
 - tool can be very difficult to move up
 - wire above it will ball up and become tighter as it jarred up
 - cannot be released from its bite once wire is wrapped around



- **Cutter Bar**
- To cut wire at top of rope socket of toolstring which cannot be retrieved
- Made of rope socket, stem and blind box
- Can be run on SB tool
- Criteria blind box: OD to suit ID of tubing and OD of rope socket

- **Sidewall Cutter**

- To run down into well and beside the broken wire and cut against the tubing wall
- Clear down to ball of wire
- Can be run on SB
- Has shear pin which prevent from extending
- Jar down to expand and harden blades radially outwards



**SIDE WALL
CUTTER**

- **Bevelled/Angled Bottom Go-Devil**
- Used to slide down wire and cut at rope socket by a slicing action
- Length is determined by well content:
 - long in heavy oil
 - short in light fluid
- Not recommended in gas

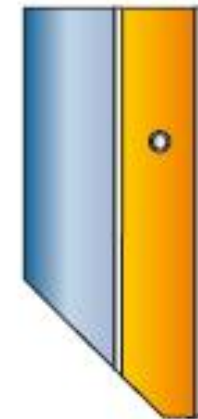

**GO DEVIL
45° ANGLED
BOTTOM**

- **Flat Bottomed Go-Devil**
- Used to:-
 - trip flopetrol cuter and kinley
 - provide a cutting base on sand/wire
 - add weight to the toolstring to jar down
 - assist the toolstring back into tubing



GO DEVIL
FLAT BOTTOM

- **Flopetrol Cutter**

- Required when wire must be cut in well
- Run down under its own weight guided by line and when it strikes the stuck tool, it cuts the wire
- Some, cuts wire and wedges it into the body
- Retrieved along with the cut wire



**WIRELINE
CUTTER**

Safety Sharing

Slips, Trips and Falls

- Slips occur when there is little to no traction between the footwear and the walking surface. Since the friction is too small to hold the feet on the ground, a person can lose their balance. For example, when spilled oil on the workplace floor and stepped-on, they will most likely slip on the floor.
- On the other hand, tripping happens when a person's foot hits an object or steps down to a lower, uneven surface. Any of the two can disrupt a person's balance and make them lose their footing. For example, a mechanic can trip on tangled hoses lying on the floor.
- Falls are the number one cause of fatalities among construction workers. They can happen to anyone if they stumble and fall too far off their center balance. For example, a crew can fall from a gin-pole while setting a chain block.

***THANK YOU FOR
YOUR TIME!***



***By
Mohammad Farhan bin Saifudin***