

An aerial photograph of a large offshore oil rig in the middle of the ocean. The rig is a complex of yellow and white metal structures, including a tall derrick and various platforms. The water is a deep blue. The text 'TRAINEE ASSESSMENT' is overlaid in large white letters across the center of the image.

# TRAINEE ASSESSMENT

---

AHMAD SYAHIR KHAIRUDDIN

# TABLE OF CONTENT

1. HSSE
2. SLICKLINE
3. DOWNHOLE TOOL
  - BASIC TOOLSTRING
  - PULLING TOOLS
  - SERVICE TOOLS
4. PRESSURE CONTROL EQUIPMENT
5. SURFACE EQUIPMENT
6. CONCLUSION
7. JOB SUMMARY
8. Q & A SESSION



# Safety Policy

- DB management is committed to fostering a safe and healthy work environment while conducting all business operations in an environmentally sustainable manner.
1. Driving Policy
  2. Drugs & Alcohol Policy
  3. Harassment In The Workplace Policy
  4. HSSE Policy
  5. PPE Policy
  6. Smoking & Vaping Policy
  7. Stop Work Policy

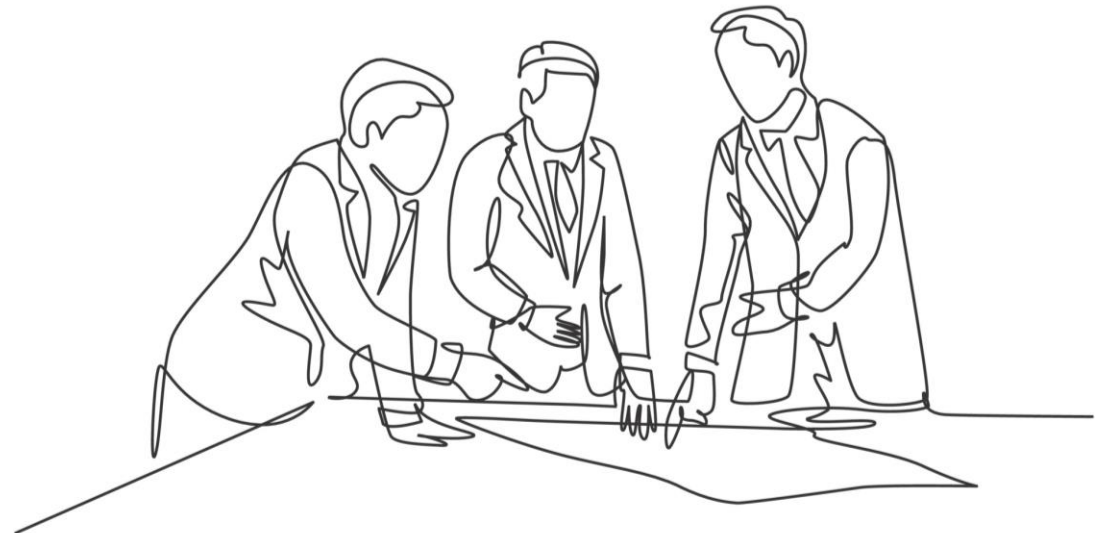

# Golden Safety Rules

- Golden safety rules are fundamental principles designed to prevent accidents and injuries in the workplace. These rules are typically easy to remember, and cover essential safety practices.

1. Personal ownership of Safety
2. Stop Work
3. Risk Assessment
4. Management of Change
5. Full Compliance of PPE
6. Working at Height
7. Lifting Operations
8. Approved PTW (Permit to work)
9. Operate Vehicles Safely
10. Avoid position in the line of fire



# Personal Protection Equipment (PPE)

---

1. Coverall
2. Hard Hat
3. Ear Plug
4. Safety Glasses
5. Gloves
6. Safety Boot



## Why Is PPE Important

PPE, or Personal Protective Equipment, is crucial for safeguarding workers from potential hazards in the workplace. It serves as the last line of defense when other safety measures fail

### When do employees need to wear PPE

1. Working on or around hot, wet or slippery surfaces.
2. Working when electrical hazards are present.
3. Handling the hazardous substances and uncontained chemicals.
4. Working at the high place or place with high tendency of falling objects.
5. Working around overhead tools or machinery.
6. Working with highly toxic chemicals or dusty environment



# Permit To Work (PTW)

- A Permit to Work (PTW) is a formal authorization document used in workplaces to control high-risk activities. It's a crucial safety management tool that ensures proper safety measures are in place before work commences, reducing the risk of accidents, injuries, and incidents.

## When is a PTW Required?

PTWs are typically used for:

1. High-risk activities: Working at heights, confined spaces, hot work (welding, cutting), electrical work, and working with hazardous substances.
2. Non-routine tasks: Work that is not part of regular operations.
3. Contractor work: When external contractors are involved.

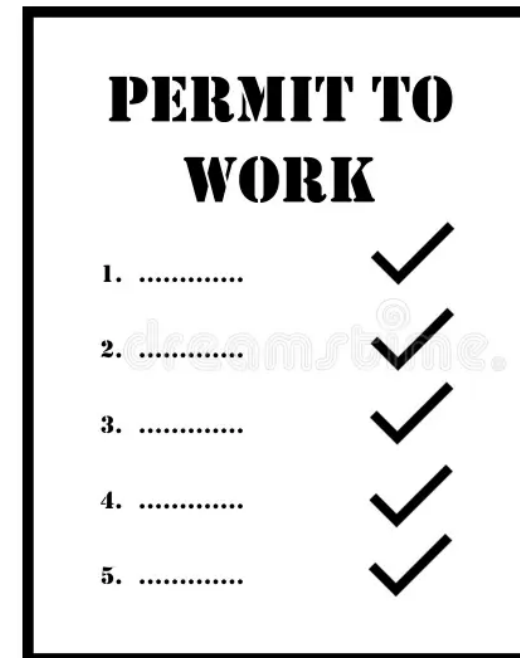

# Job Hazard Analysis (JHA)

- A Job Hazard Analysis (JHA) is a systematic process to identify potential hazards and risks associated with a specific job or task. It involves breaking down the job into steps, identifying potential hazards at each step, and determining preventive measures to control these hazards.

JOB STEP	DESCRIPTION OF JOB STEP	POTENTIAL HAZARD	POTENTIAL CONSEQUENCES	CONTROL BARRIERS	ACTION PARTY	RECOVERY BARRIERS	ACTION PARTY
1	Check Condition Diesel	<ul style="list-style-type: none"> <li>• Incorrect refueling method</li> </ul>	<ul style="list-style-type: none"> <li>• Spill oil</li> <li>• Sharp edge</li> </ul>	<ul style="list-style-type: none"> <li>• Wear rubber glove.</li> </ul>	wireline	Apply first aid and get medical assistance if the injuries are severe	wireline
2	Check diesel level in power pack and air compressor	<ul style="list-style-type: none"> <li>• Overheat and leaking oil</li> <li>• Hydrocarbon</li> <li>• Flammable liquid</li> </ul>	<ul style="list-style-type: none"> <li>• Hand injury</li> <li>• Broken equipment</li> </ul>	<ul style="list-style-type: none"> <li>• Standby P.D.C at work site</li> <li>• Grounding Cable</li> <li>• Wear rubber glove</li> </ul>	wireline	Medical treatment	wireline

# Example JHA - Epoms

		<b>JOB HAZARD ANALYSIS [JHA] WORKSHEET</b>			
<b>JHA NO.</b>		<b>PTW NO</b>		<b>WORK PERMIT TYPE</b>	FW
<b>FACILITY :</b>		<b>LOCATION</b>	MAINDECK	<b>SPECIFIC WORKSTATION</b>	
<b>EQUIPMENT NO. :</b>		<b>WORK DESCRIPTION</b>	Perform <del>topup</del> diesel on wireline equipment		
<b>NOTE</b>					
<ol style="list-style-type: none"> <li>JHA shall be applicable for all work activities which requires PTW.</li> <li>The pre-prepared JHA and JHA prompts will be used as a reference/guide during the development of JHA.</li> <li>Personnel carrying out the work shall be fully familiar with the written Work/Operating Procedures developed for the job. The Work/Operating Procedures shall describe, in step-by-step instructions, the correct method of executing the specified work.</li> <li>Prior to commencement of work (after PTW has been approved), the task-specific JHA shall be discussed amongst all personnel involved in the execution; and requirements contained therein shall be fully understood and agreed by all involved personnel.</li> </ol>					

JOB STEP	DESCRIPTION OF JOB STEP	POTENTIAL HAZARD	POTENTIAL CONSEQUENCES	CONTROL BARRIERS	ACTION PARTY	RECOVERY BARRIERS	ACTION PARTY
1	Preparation for PTW	<ul style="list-style-type: none"> <li>Wrong job or task.</li> <li>To avoid clash of work at platform</li> <li>Incomplete detail of work.</li> </ul>	To avoid clash of work at platform	<ul style="list-style-type: none"> <li>PTW approval from in charge personal.</li> <li>Competent personal to conduct the operation.</li> <li>Inform to all crew on location and description of work</li> </ul>	wireline	Ensure all team member review <del>jha</del>	wireline
2	Pre Job Meeting	<ul style="list-style-type: none"> <li>Wrong job or task.</li> <li>To avoid clash of work at platform</li> <li>Conflict of work.</li> </ul>	Other parties are not aware where you are performing the job	<ul style="list-style-type: none"> <li>Inform to all crew on location</li> <li>Inform the hazard involved at place of work</li> </ul>	wireline	Ensure team member not miss toolbox meeting	wireline

# Slickline

- **What is Slickline?**
- Slickline is a single-strand wire used to deploy various tools into the wellbore for multiple purposes during well drilling operations in the oil and gas industry.
- It is specifically utilized to lower downhole tools into an oil or gas well to carry out maintenance tasks.



# SLICKLINE

---

- **SLICKLINE WIRE**

- Solid wireline is available in various diameters, including 0.092", 0.108", 0.125", 0.140", and 0.160" (with 0.140" being commonly used in fishing operations at Dimension Bid).

There are three different types of wire used:

- ZERON (100 HS Stainless Steel)
- EIPS (Carbon Steel EIPS Grade)
- ZAPP (SUPA 75 Alloy)



## OPERATION

TCC (TUBING CLEARANCE CHECK) : Tubing Drift, Gauge Ring, LIB

Gas Lift Job (Retrieve & Set GLV/Dummy)

# Basic Tool String

1. Rope Socket
2. Swivel Joint
3. Stem
4. Knuckle Joint
5. Jar



# Rope Socket

- To connect the wire to the tool string, three types of Rope Sockets (RS) are used: Tear Drop (available in 0.108", 0.125", and 0.140" sizes), Regular Knot Type (0.092"), and Braided Clamp.



Spring and Disc Type



Pear Drop Wedge Type

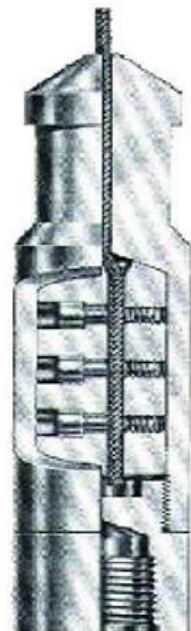

Braided Clamp Type

OD (in)	Fish Neck (in)
1"	1.000"
1.1/4"	1.187"
1.1/2"	1.375"
1.7/8"	1.750"
2.1/8"	1.750"
2.1/2"	2.313"

# How to make up Rope Socket

- Get in the wire into rope socket and follow up by timber eye sleeve.
- Bend the wire 90-degree, measure wire with timber eye, bend the other side.



- Put the wire into timber eye, measure and cut the wire.
- Make sure wire fit on timber cross section.



- Put thimble eye into the timber sleeve.



# Done

---



# Swivel Joint

---

- A swivel joint in slickline operations is a mechanical device that allows rotation between connected components without twisting the wireline. It is commonly used to prevent the wireline from becoming twisted during downhole operations, ensuring smooth and efficient tool deployment and retrieval.



O.D. (in.)	Fishneck O.D. (in.)
1.1/4	1.187
1.1/2	1.375
1.3/4	1.375
1.7/8	1.750
2.1/8	1.750
2.1/2	2.313

OD (inc)	Weight lb/ft	Fishing Neck
1	2.5lbs	0.875"
1.1/4	4.2lbs	1.187"
1.1/2	6.0lbs	1.375"
1.7/8	9.4lbs	1.750"
2.1/8	12lbs	1.750"
2.1/2	16.7lbs	2.313"

## Stem

- Stem is a weighted steel rod that is attached to the tool string. It serves two primary purposes:
  1. Providing additional weight to help the tool string descend into the wellbore
  2. Ensuring the tool string remains stable and properly aligned during downhole operations.





## Knuckle Joint

- A knuckle joint in slickline operations is a flexible connection in the tool string that allows for angular movement between connected components.
- Max15 degree angle



O.D. (in.)	Fishneck O.D. (in.)
1.1/4	1.187
1.1/2	1.375
1.7/8	1.750
2.1/8	1.750

## Jar

- Function: a downhole hammer upward and downward to provide impact.
- 20” and 30” stroke.
- Mechanical Jar, Hydraulic jar, spring jar, Tubular jar ,etc

# Downhole Tools Connection

1. Sucker Rod Thread
2. Quick Lock System
  - Shear pin Size
    1. 1/8
    2. 3/16
    3. 1/4
    4. 5/6
    5. 3/8



# Pulling Tool

- Otis ` S type (Jarring down to shear)
  - SB
  - SS
- Otis ` R type (Jarring up to shear)
  - RS
  - RB
- Otis ` GS (Jarring down to shear)
- Otis ` GR (Jarring up to shear)



# OTIS `S Series Pulling tool

- S Series pulling tool used to engage an external fishing neck.
- SB (Long Core – Short Reach)
- SS (Short Core - Long Reach)
- Jarring down to shear pin.
- Top sub not attached directly to core.



Sleeve on "S"



Tool Size (in)	Fishing Neck (in)	Pulls F/Neck
1.1/2 SB	1.187"	1.187"
2 SB	1.375"	1.375"
2.1/2" SB	1.375"	1.750

# OTIS S' Series Pulling Tool

## SB

Size (ins)	OD (ins)	Fish Neck
1.1/2	1.437	1.187
2	1.766	1.375
2.1/2	2.188	1.375
3	2.734	2.313

## SS

Size (ins)	OD (ins)	Fish Neck
1.1/2	1.437	1.187
2	1.766	1.375
2.1/2	2.188	1.375
3	2.734	2.313



SB Pulling Tool

SS Pulling Tool

# COMPONENT OTIS `S PULLING TOOL

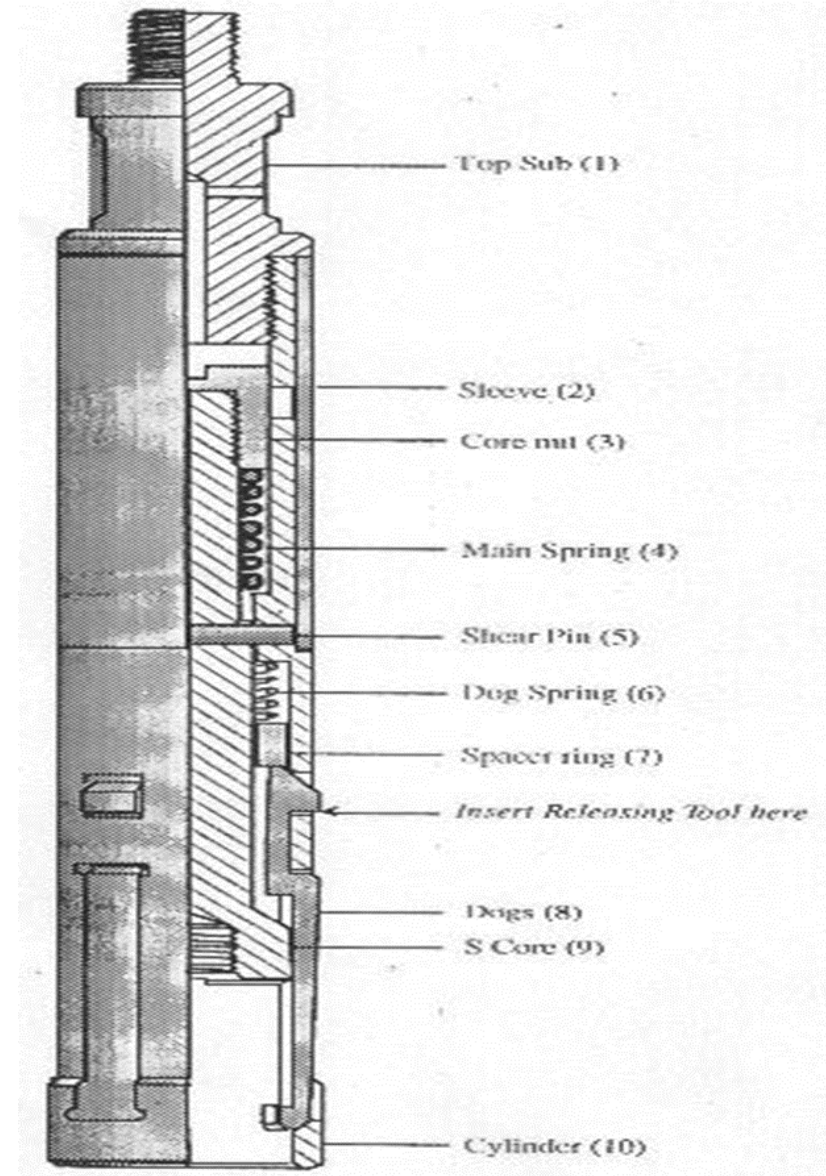

# OTIS `R Series Pulling Tool

1. To engage an external fishing neck.
2. RB (Long Core - Short Reach)
3. RS (Short Core - Long Reach)
4. Jarring up to shear pin



Ring on "R"



# OTIS `R Series Pulling Tool



RB Pulling Tool



RS Pulling Tool

## RB

Size ( ins)	OD (ins)	Fish Neck
1.1/2	1.430	1.187
2	1.770	1.375
2.1/2	2.180	1.375
3	2.740	2.313

## RS

Size ( ins)	OD (ins)	Fish Neck
1.1/2	1.430	1.187
2	1.770	1.375
2.1/2	2.180	1.375
3	2.740	2.313

# COMPONENT OTIS R SERIES PULLING TOOL

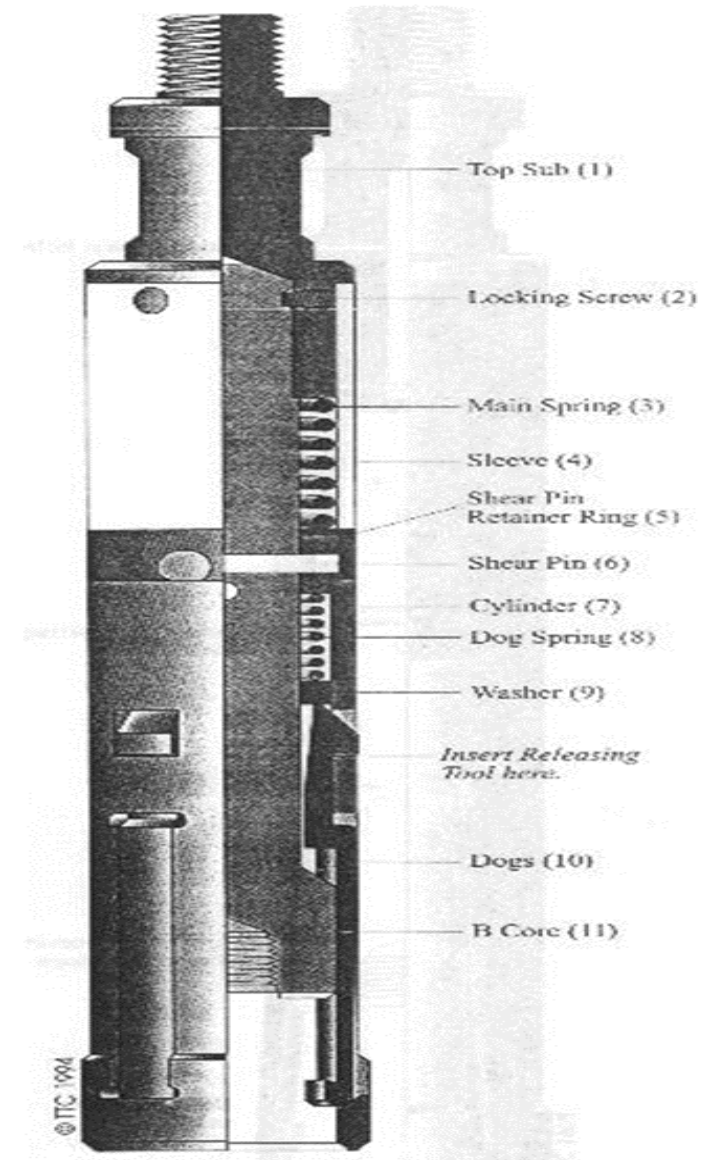
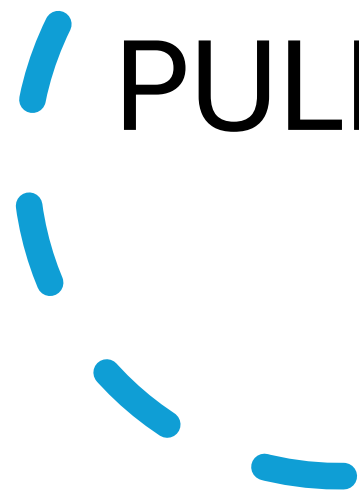

## Tools for 'R' and 'S' series

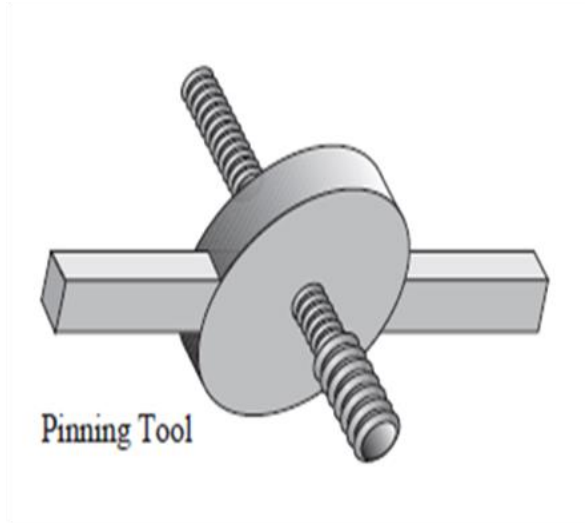

Used to re-pin the pulling tool 'R' and 'S' Series  
*\*Inserting it into the bottom of tool*

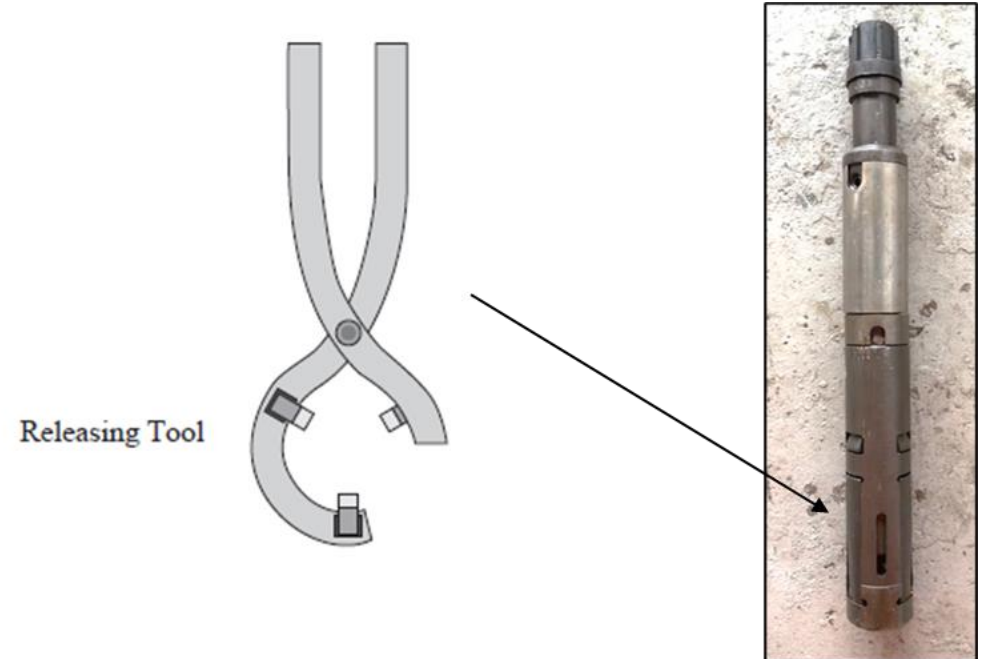

Used to release pulling tool 'R' and 'S' Series  
from the fish engaged

# OTIS GS Pulling Tool

1. Jarring down to shear pin.
2. To pull any subsurface flow control devices which have internal fishing neck.

Nominal Size (ins)	Tools O.D (ins)	Tool Fish Neck (in)
2	1.875	1.375
2.1/2	2.313	1.750
3	2.750	2.313
5	4.562	2.125



# COMPONENT OTIS GS PULLING TOOL

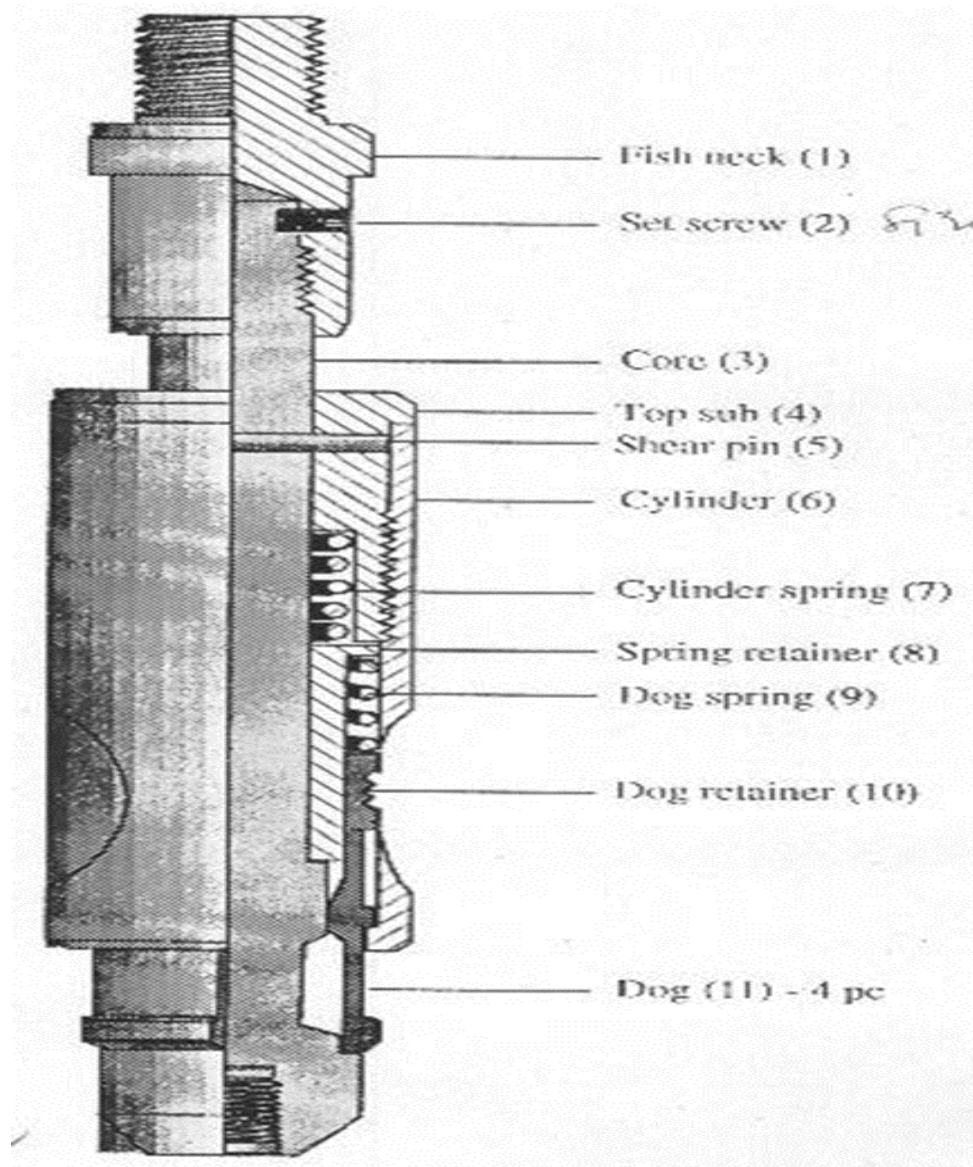

# OTIS GR Pulling Tool

- Jarring upward to shear.
- Used for setting and retrieving items with internal "Otis" type fish necks.
- The pin **MUST BE REMOVED** from the GS tool, otherwise, it will not shear in either direction.
- This involves a combination of GS and GU tools.



# COMPONENT OTIS GR PULLING TOOL

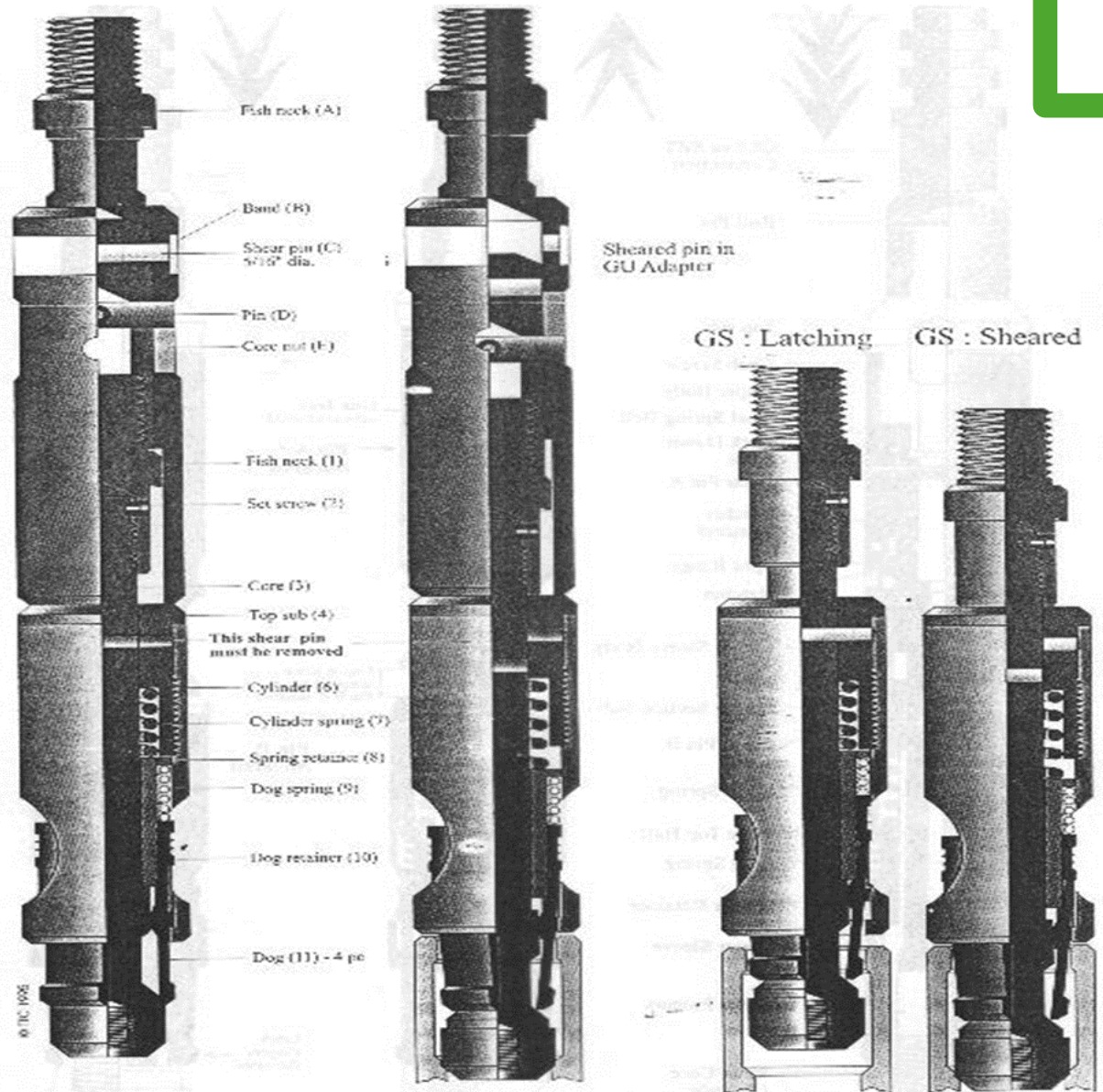

# Service Tools

Tubing Drift

Gauge Cutter

Wire  
Scratcher

Lead  
Impression  
Block

Fluted  
Centralizer

Blind Box

Tubing Swage

Tubing  
Broach



---

## Tubing Drift

- A tubing drift in slickline operations is a cylindrical gauge.
- It is used to verify the internal diameter of well tubing.
- Ensures the tubing is clear of obstructions.
- Confirms proper clearance for downhole tools.
- Helps verify that the wellbore is free from restrictions that could impede tool movement.

# Gauge Cutter

Gauge Cutter		
O.D. (in.)	Fishneck O.D. (in.)	Bottom Connection (in.)
1.25 – 1.50	1.187	15/16
1.50 – 2.00	1.375	15/16
2.00 – 2.50	1.375	15/16
2.50 – 3.00	1.750	1.1/16



- Gauge cutter is a slickline tool used to verify the wellbore diameter.
- It is designed to detect and clear obstructions or debris in the wellbore.
- To check tubing ID, tag total depth, locate the nipple ID and No-Go, cut sand/scale/paraffin from tubing wall.
- Typically run before deploying other downhole tools to confirm wellbore clearance.
- Helps prevent tool string from getting stuck during operations.



# Wire Scratcher

---

- Used to clear wax, scale, and sand from tubing walls, nipple profiles, SSD sleeves, and Side Pocket Mandrels.
- A wire scratcher is a brush-like tool designed for this purpose.
- If the wire scratcher is ineffective in removing deposits, a gauge cutter, ring, or tubing broach will be used as alternatives.

Wire Scratcher		
O.D. (in.)	Fishneck O.D. (in.)	Bottom Connection (in.)
1.000	1.375	15/16
1.500	1.375	15/16
1.875	1.750	1.1/16
2.125	1.750	1.1/16

## Lead Impression Block

O.D. (in.)	Fishneck O.D. (in.)	Bottom Connection (in.)
1.25 – 1.50	1.187	15/16
1.50 – 2.00	1.375	15/16
2.00 – 2.50	1.375	15/16
2.50 – 3.00	1.750	1.1/16

### Lead Impression Block

- Function: Used in fishing operations to assess the shape or size of the top of the fish.
- Helps determine the appropriate tool needed for the fishing operation.
- Also referred to as the "slickline bottom-hole camera."



## Fluted Centralizer

O.D. (in.)	Fishneck O.D. (in.)	Bottom Connection
1.50 – 2.50	1.375	15/16
2.50 – 3.50	1.750	1.1/16
3.50 – 4.50	2.313	1.9/16

### Fluted Centralizer

- Is used in deviated wells to ensure the toolstring remains in a centralized position.



# Blind Box

- Function: Utilized when heavy downward jarring is needed to dislodge a fish or push an object down the hole.
- Acts as a "Cutter Bar," severing the wireline at the top of the rope socket when the tool string cannot be retrieved.
- The flat bottom surface is hardened to minimize wear and damage.



## Tubing Swage

O.D. (in.)	Fishneck O.D. (in.)	Top Connection (in.)
1.25 – 1.50	1.187	15/16
1.51 – 2.50	1.375	15/16
2.51 – 3.00	1.750	1.1/16
3.01 – 5.00	2.313	1.1/16

### Tubing Swage

- Function: Used to restore minor tubing collapses and remove large obstructions.
- Recommended to run with a hydraulic or spring jar to allow the operator to jar upward if the swage becomes stuck in the tubing.



# Tubing Broach

- Function: Removes burrs and buildup within the wellbore, as well as scale and rust from the tubing's internal diameter.
- Available Types:
  - Diamond Cut Broach
  - Straight Cut Broach

Tubing Broach		
O.D. (in.)	Fishneck O.D. (in.)	Top Connection
1.50 – 2.50	1.375	15/16
2.51 – 4.00	1.750	1.1/16
4.01 – 5.00	2.313	1.1/16
5.01 – 6.00	3.125	1.9/16



Diamond Cut broach



Straight Cut broach

# Pressure Control Equipment (PCE)

---

- Stuffing Box
- Lubricator
- Quick Test Sub
- Blowout Preventer
- Ball Valve
- Wellhead Crossover
- Control Panel
- Single Well Control Panel



# Quick Union

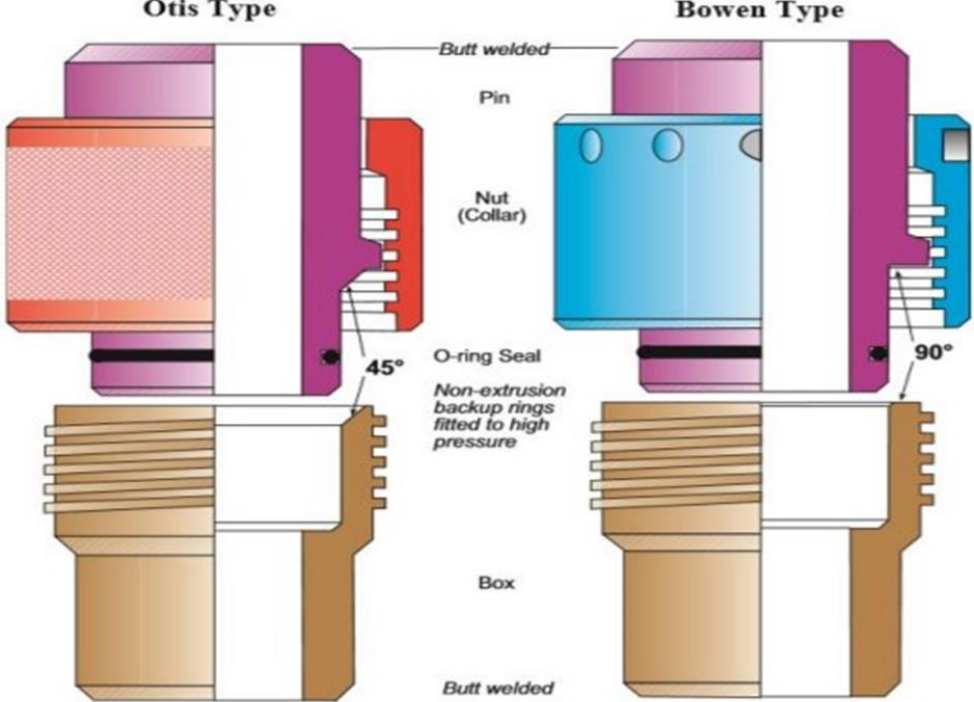
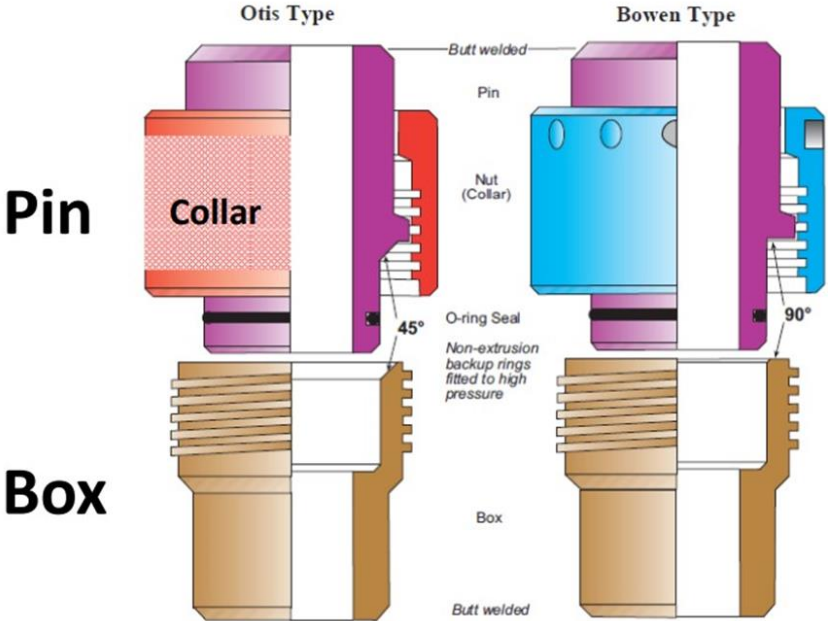

## Components/Parts

---

- Otis type connection - 45 degree angle.
- Bowen type connection - 90 degree angle.

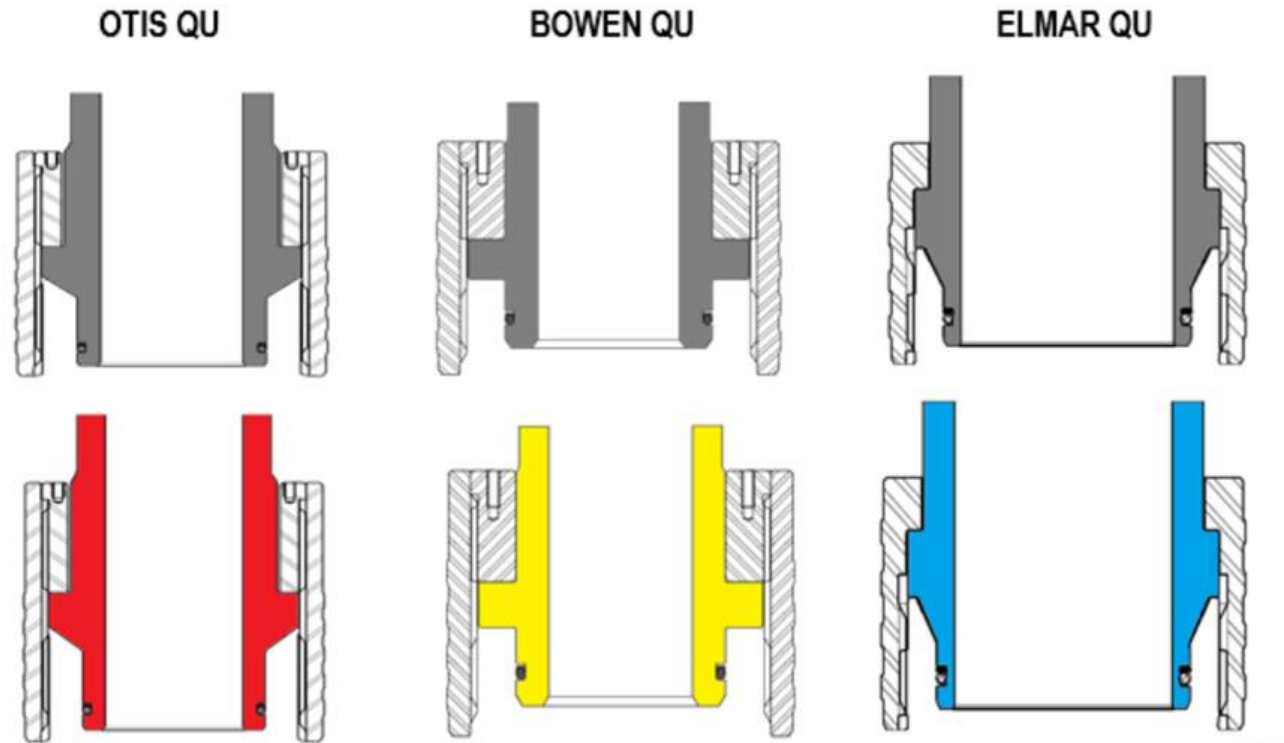



# Stuffing Box

- Sealing Device: Connected to the top of lubricator sections.
- Primary Barrier: Serves as the main barrier in operations.
- Wire to Sheave Ratio: 1:120.
- Hydraulically Controlled Packing Nuts: Available for use; can be operated with a hand pump.

# Components / Parts

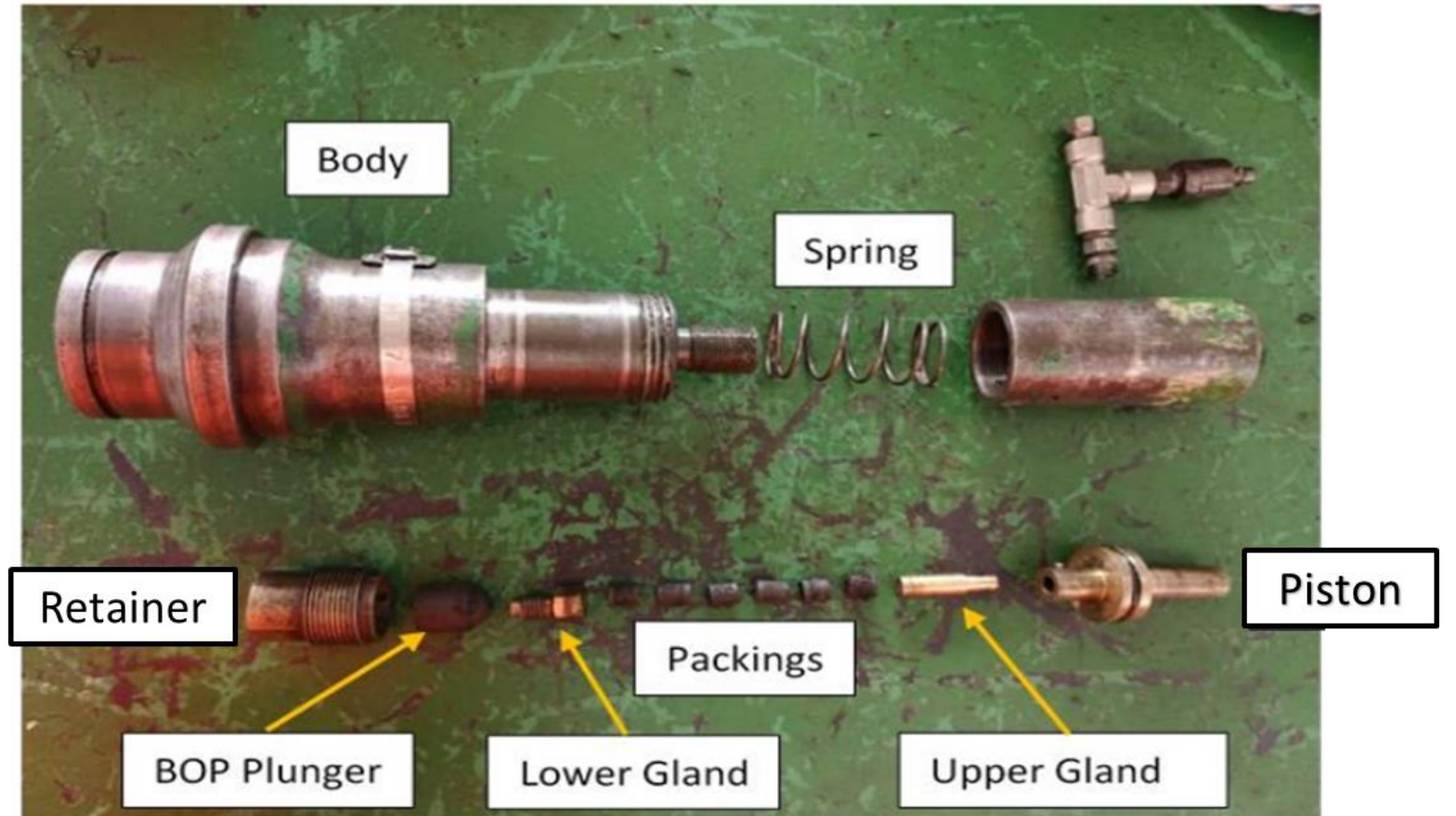

# Lubricator

---

- Lubricator: Allows wireline toolstring to be inserted and removed from a well under pressure.
- Types: Ported Lubricator: Includes a bleed-off valve to vent pressure from the well.
- Non-Ported Lubricator: Does not have a bleed-off valve.
- Length: 8 feet for the main lubricator.
- Pup Joints: Available in 2, 3, and 4-foot lengths.



# Quick Test Sub

- Purpose: Used for pressure testing pressure control equipment (PCE).
- Features: Equipped with two O-rings at the disconnection points.
- Can be tested with hydraulic pressure to ensure the PCE can still hold pressure.



# Blowout Preventer (BOP)

---

- Secondary Barrier: Functions as an additional safety measure.
- Pressure Holding: Maintains pressure from one direction.
- Operation: Hydraulic force is used to close rams that seal around the wire.
- Control: Operated via a control panel.



# Ball Valve

---

- Design: Holds pressure from both below and above.
- Operation: Can be operated hydraulically or with a manual handle.
- Features: Ball valves available for cutting wire.
- Safety: Provides additional safety for shutting the well; positioned below the wireline valve/BOP and above.

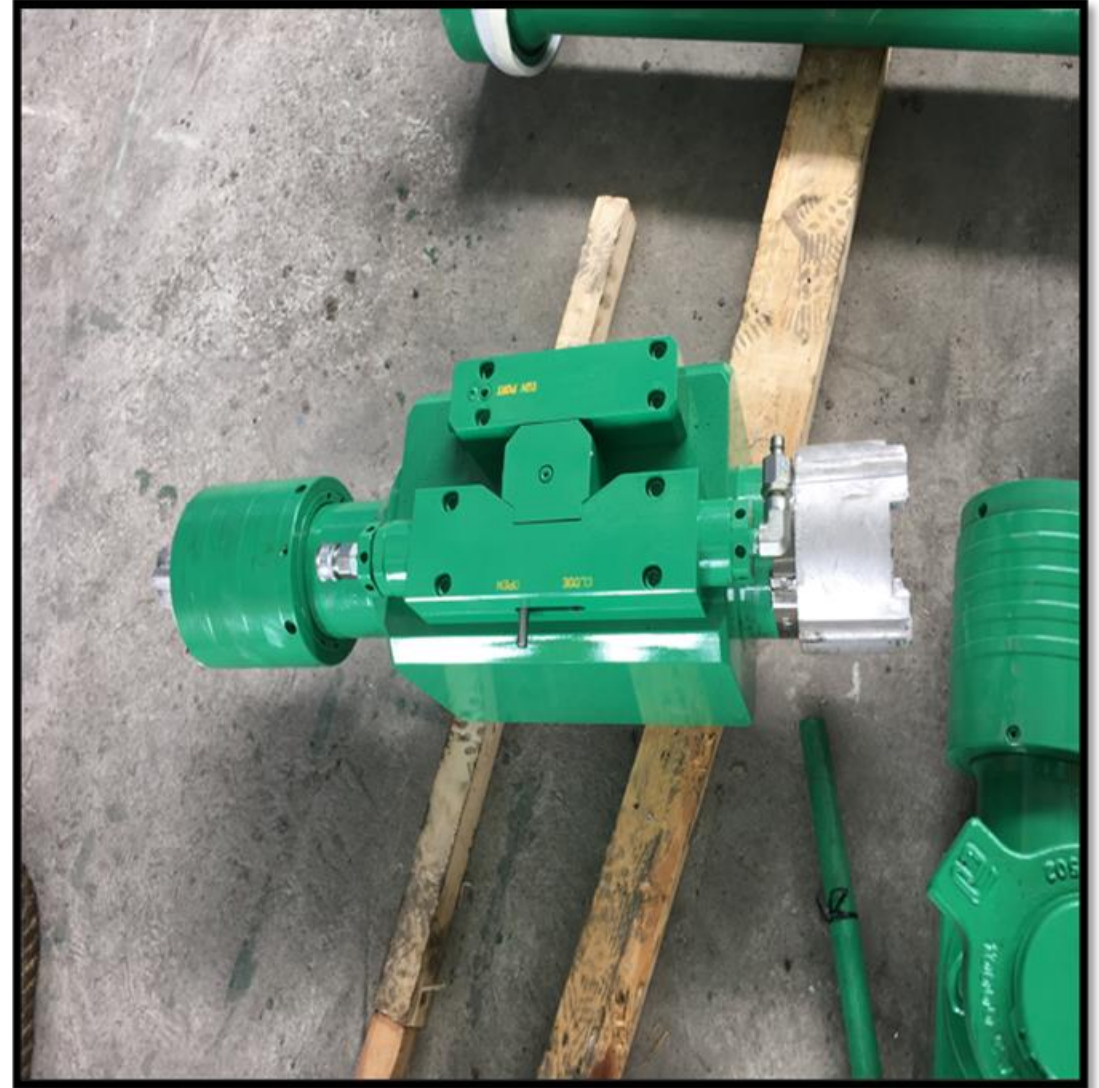

# Wellhead Crossover

---

- **Connection:** Links to the wellhead, allowing pressure measurement and control equipment to interface with the wellhead.
- **Purpose:** Provides pressure seals for casing strings extending from the surface to the bottom of the wellbore.
- **Variety:** Different wellheads require different sizes of wellhead adapters.



# Control Panel

- Purpose: Operates dual ram BOP, stuffing box, safety valve, master valve, and test line.
- Emergency Shutdown: Includes an emergency shutdown facility.
- Function Test: Conducts tests at pressures between 2000 psi and 3000 psi.



# Single Well Control Panel

---

- Purpose: Ensures safe and reliable operation of Xmas tree valves by providing hydraulic power and controls.
- Operates: SSV (actuator 2800 psi) and TRSCSSV (3800 psi).
- Equipment: Equipped with 2 Haskel pumps.
- Max Working Pressure: 10,000 psi.
- Function Test: Conducts tests at pressures between 5,500 psi and 6,500 psi.



# PCE Accessories



*Enerpac Hand Pump*



*Hunting Lifting Clamp*



*Hunting Lifting Cap*

# Surface Equipment

---

- Wireline Mast
- Air Compressor
- Power Pack
- Reel Skid Unit

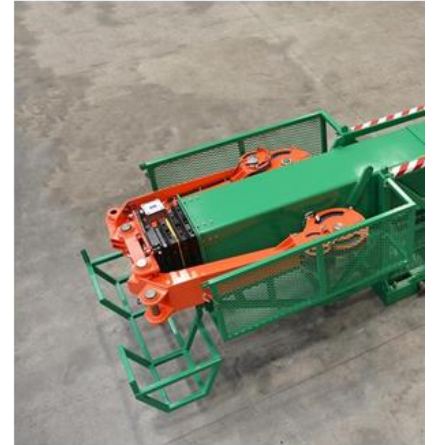

# Oil and Gas Hazardous Zone

## Oil and Gas Hazardous Zone

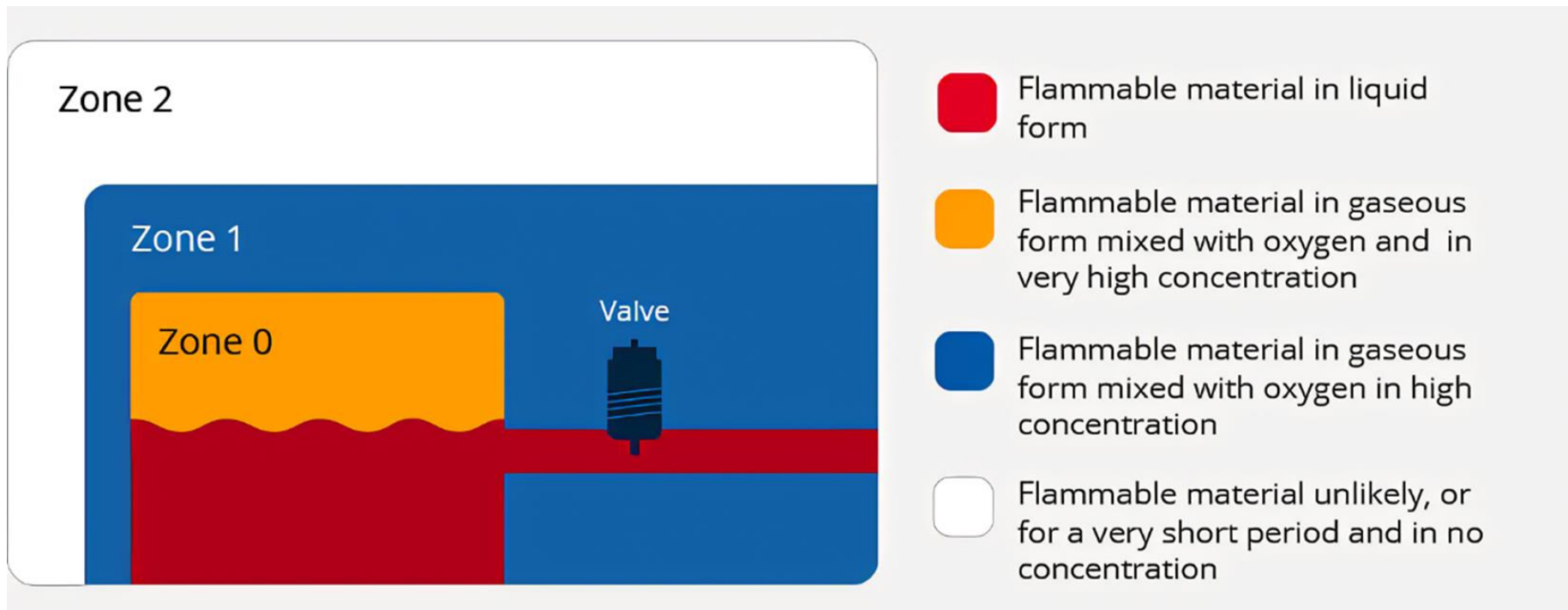

# Wireline Mast

---

- Function: Lifts and hangs the lubricator during wireline operations.
- Zone: Zone 1.



# Wireline Mast Control

1. Inlet pressure gauge
2. Erector
3. Extender
4. Block (green)
5. Block (red)

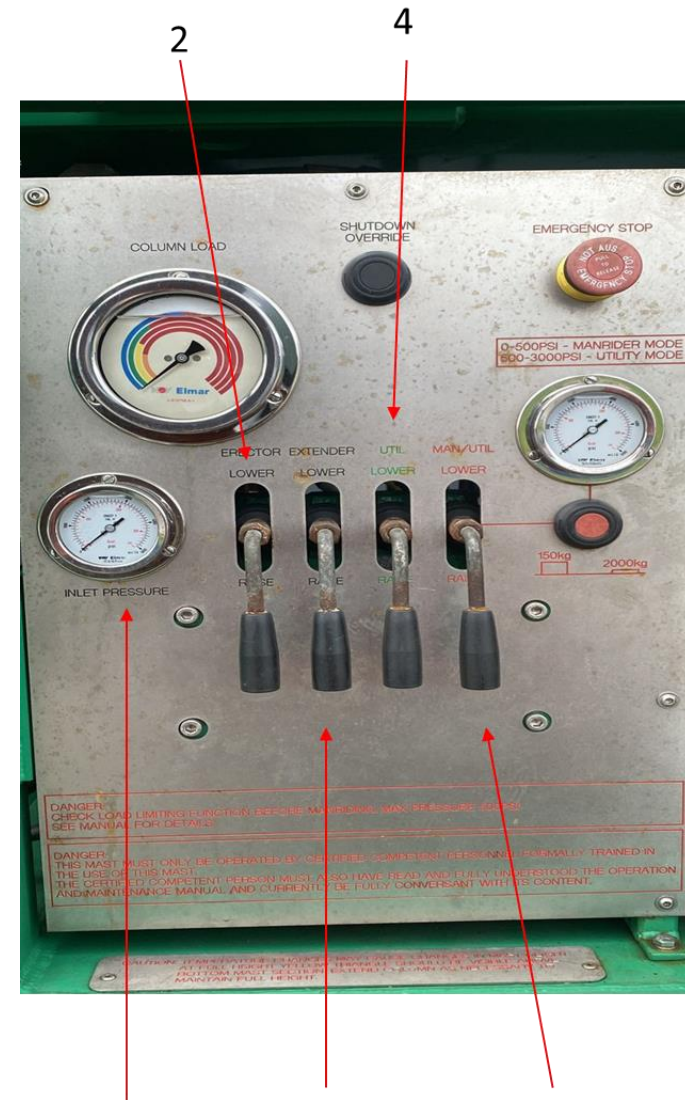

# Air Compressor

---

- Function: Supplies air.
- Rating: Zone 2 rated equipment.
- Start: Equipped with both spring and hydraulic starters.



# Power Pack

---

- Type: Diesel-driven power pack.
- Certification: Zone 2 hazardous area rated equipment.
- Starters: Includes spring, hydraulic, and air starters.
- Function: Provides and supplies hydraulic power to the reel skid unit and wireline mast.
- Hydraulic Supply: Delivers hydraulic power to the reel skid unit at 2500 psi.
- Requirement: Requires a hot work permit.



# Powerpack Daily Checklist

- Hydraulic oil
- Engine oil
- Radiator
- Coolant
- Oil filter
- Connection hose

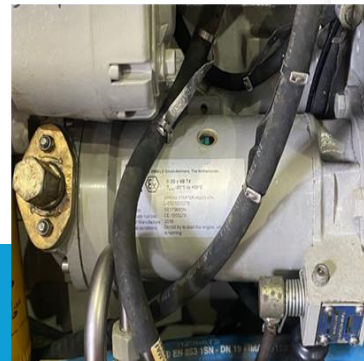

1. Rotate the sentinel valve clockwise.

2. turn the winding nut till the spring tension sight glass turn to green.

4. Engine oil pressure at 40-60psi

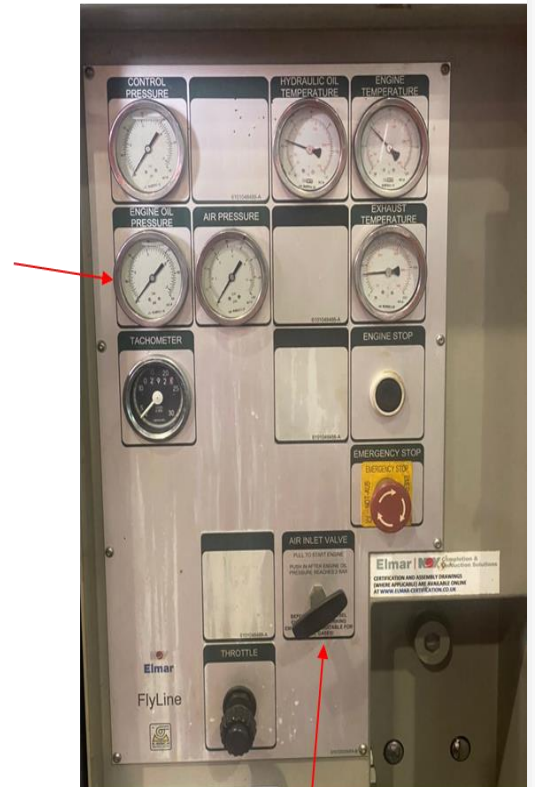

3. Pull the air inlet valve up.

# Reel Skid Unit

---

- Purpose: Wireline winch is used for lowering and raising the toolstring in the well.
- Direction Lever: Selects the direction of the drum's rotation.
- Drum Brake: Keeps the drum stationary or is used during jarring.
- Hydraulic Control Valve: Controls the speed of drum rotation.
- Odometer: Indicates wireline depths.
- Weight Indicator: Measures the tension on the wireline.





## Conclusion

- Function Equipment and Tools: Understand their roles and uses.
- Basic Rig-Up Process: Learn the fundamental rig-up procedures.
- Slickline Operation: Learn the steps involved in slickline operations.
- Preventive Maintenance: Learn how to perform routine preventive maintenance.



# Job Summary

- Monitor WHCP for CTU job (BLB-CHESS)
  - Set insert valve (BLB-CHESS)
  - Monitor WHCP for Eline job(BLC-CHESS)
  - Set insert valve (HESS)
  - GLVCO & retrieve pxx plug (VESTIGO LARUT)
  - Set kx valve (SYA-CHESS)
  - TCC & perforation (VESTIGO LARUT)
  - GLVCO (VESTIGO LARUT)
-



Q & A Session