

SLICKLINE ASSISTANT WORKBOOK

IMPORTANT NOTE:

1. Your point of reference to complete this workbook may be obtained from the following
 - Training Manual and any other training materials provided together with this workbook
 - Your Trainer, Assessor (Slickline Operator), Verifier (FSM) or senior colleagues
 - SOP / Quality Procedures & Processors
2. The completion of this Workbook is a joint effort and responsibility between you and your assessor therefore you have the obligation to request from your assessor to be assessed upon your completion of each topic
3. The completion of this Workbook is part of the MANDATORY requirements which you must fulfill to qualify for a promotion
4. Your training program is mostly self-driven, including this Workbook. It requires individual initiatives, dedication and commitment to complete the process.

NAME	Aubrey Andrew Bernard
DATE OF JOIN	
CONTACT NO.	
RECEIVED DATE	11.06.2019
DATE COMPLETED	

TABLE OF CONTENT

Topic	Page
Introduction	2
Public Course Records & In-house Training Records	3-5
Module 1: Basic of Wireline - Equipment and Operation	
Assessment Summary	7
Wireline Operations Basic Safety	8-14
Basic Surface Equipment	15-40
Basic Downhole Tools	41-46
Basic Rig up Wireline Surface Equipment	47-50

NAME <i>Adrian Andrew</i>	
DATE OF JOB	
CONTACT NO.	
RECEIVED DATE <i>11-06-11</i>	
DATE COMPLETED	

INTRODUCTION

CORPORATE PROFILE

Dimension Bid is a Malaysia-based International Well Intervention and Perforation Services company, specializing in Slickline Intervention, Cased Hole Electric Line Logging, Coiled Tubing Services and Braided Line Fishing. Established in 1994 and home-grown, Dimension Bid has developed into a full-fledged intervention service company, having more than 20 years of experience in providing services to National Oil Companies and Multi-National Oil Companies domestically and internationally. Our footprint is located across Malaysia, South East Asia and Central Asia, reflecting our ambition to be a truly global Well Intervention Solutions Partner.

THE GROWTH

Growing from strength to strength our list of client includes Sarawak Shell, ExxonMobil, PCSB and Talisman-Energy Malaysia Limited, ROC Oil, just to name a few. Our involvement expanded from production drilling operations

OUR TEAM

From a humble beginning of 18 employees in 1997, Dimension workforce has now grown to over 200 employees. we believe in realizing full potential of every employee - reason for substantial investment allocated to train everyone, both locally and abroad, in order to achieve the expected high performance and professionalism.

MISSION

To enrich client's business through our expertise in providing an integrated, high-value added solutions in the oil and gas industry.

VISION

To be a Solution Partner of choice to our clients.

THE PHILOSOPHY

Continuous pursuit of excellence in anything we do.



PUBLIC COURSE RECORDS

1. Offshore Safety Orientation

Date Training	Venue	Expiry Date

2. Sea Survival

Date Training	Venue	Expiry Date

3. Basic Fire Fighting

Date Training	Venue	Expiry Date



4. H.U.E.T

Date Training	Venue	Expiry Date

5. Permit to Work

Date Training	Venue	Expiry Date

6. IWCF

Date Training	Venue	Expiry Date



Module 1: Basic of Wireline - Equipment and Operation

DESCRIPTION		THEORY & ASSIGNMENT		
		DATE	ASSESSED & APPROVED BY	VERIFIED & APPROVED BY
A	Basic Safety			
1	PPE			
2	Responsibilities			
3	Policies			
4	Hazard ID & Incident Report			
5	Operational Safety			
B	Surface Equipment Familiarization			
1	Stuffing box			
2	Lubricator			
3	Blow Out Preventer (BOP)			
4	X-Mass Tree			
5	Wireline Reel Skid Unit (Single Drum & Double Drum)			
6	Odometer			
7	Weight Indicator (200 lbs and 4000 lbs)			
8	Spooling Device			
9	Control Panel			
10	Huskel pump			
11	Power Pack (Electrical & Diesel)			
12	Air Compressor			
13	Drum			
C	Downhole Equipment Familiarization			
1	Basic Toolstring			
2	Pulling / Running Tools			
3	Wireline Wire			
4	Inspection / Maintenance of Tools			
D	Rig-up Wireline Surface Equipment			
1	Wireline Mast			
2	Lubricator Assembly			
3	Operating the BOP			
4	Make Rope socket and Toolstring Configuration			
5	Toolstring Configuration			
6	Operate the Control Panel and Huskel Pump			
7	Service of basic wireline tools			

Comment:



Module 1: Basic of Wireline - Equipment and Operation

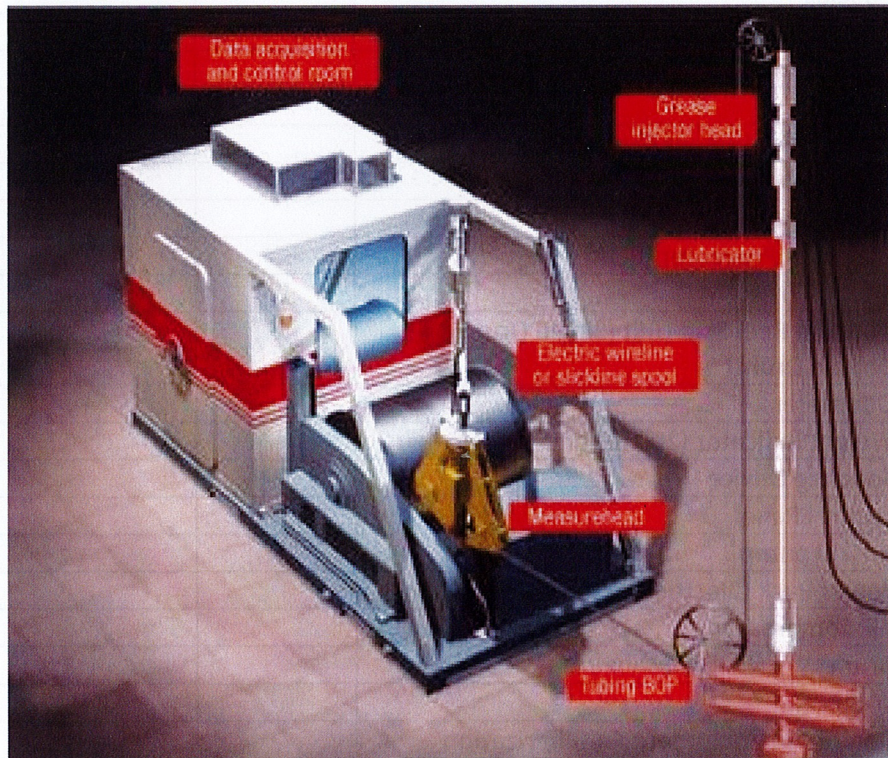



A. Wireline Operation Basic Safety Protection

1. Personal Protective Equipment

1.1 What is definition of Person Protective Equipment

Personnel protective equipment (PPE) is protective clothing, helmets, goggles, or other garments or equipment designed to protect the wearer's body from injury or infection. The hazards addressed by protective equipment include physical, electrical, heat, chemical, biohazards and airborne particulate matter

1.2 List out all compulsory PPE required to be worn while perform job offshore

Safety glasses, hand glove, hard hat, safety boots, coverall with fire retardants, ear plug

1.3 List the area where the PPE should be worn while working

worn when working or from the accommodation area which work implemented by client or company if self which include worksite area where worker do the job.

1.4 List the PPE should be worn while doing maintenance at tools and equipment

Safety helmet, glasses, impact glove, safety shoes, certified coverall with fire retardant and safety mask

1.5 PPE should you wear while working in mercury and H₂S are

Full face mask, cartridge respirator or self contained Breathing apparatus, gas detector (H₂S detector)



2. Responsibility

2.1 Employee Responsibilities towards Health, Safety and Environmental (HSE)

The employee should take care of safe about safety and health and people may be affected by his care or omission at work. Always wear the personal protective equipment (PPE), always maintain a safe work site and housekeeping, report immediately on unsafe condition. And no job is important that we can by pass the safety.

2.2 What are the safety precautions to be taken during tool maintenance at warehouse?

wear proper PPE (Impact glove, safety glasses and safety boots) correct body posture apply step back 5x5 recognize unsafe condition

2.3 When should we do housekeeping?

all the time during the task we do effective housekeeping is an on going operation when it is not a one time only.

2.4 Why housekeeping is important?

control and eliminate workplace hazard prevent slip, trip and fall or other hazards.

2.5 How should you react while seeing somebody committing into unsafe act/behavior?

Stop work and intervene the workers, discuss the hazards or injuries that will occur by unsafe act/behavior. Importantly they ensure understand and comply the procedure and safety requirement.



3. Policies

3.1 List down all DB policies in regards to HSE

- ASSE policy
- Stop work
- Smoking & Vaping
- PPE policy
- Harassment
- Drug & alcohol
- Drivably

3.2 What is HSE Policies

A healthy and safety policy is written statement by an employer stating and company's commitment for the protection of the healthy and safety of employees and to the public. It is endorsed commitment by management to its employees regarding their health and safety.

3.3 What is the purpose of 'STOP WORK' policy?

to stop any job if they have risk of injuries, health hazards, damage to properties or environment



4 Hazard ID and Incident Reporting

4.1 How can we report hazard or unsafe act?

Verbal report to a supervisor, Completing a hazard report form and then raising the issue at a staff meeting

4.2 If there is an incident happened at workplace what should we do?

- preferably remove danger from casualties, if impossible remove the casualties from danger.
- apply first aid kit treatment (if you are first aider), report to supervisor
- site first aider
- if necessary, send victim to clinic - supervisor report to H&A

4.3 What is the incident reporting process?

- 1 within 24 hours
- 2 report near miss ASAP
- 3 All reporting via Verbal & written report
- 4 All report must forward to SO, OM, EM, CEO

4.4 What is the purpose of Hazard Hunt? And how does that help to be safe?

- To aim of hazards hunt identifying risks, opening them up for discussion, eliminating them.
- The risks can be prevented by modifying procedure, this is important because potential hazards can lead to personal injury or damage to property or environment

4.5 Please explain what is Near Miss

Incident which did not result injury or illness to people or damage (loss) to assets and environment.

4.6 In case of emergency,

a) Firstly what should you do?

Stop work and secure work site area

b) Where is DB assembly point (Base)?

Designated muster point



4.7 Where can you find the emergency contact Number?

employee personal information / note board

5. Operational Safety

5.1 How to prevent an accident before executing certain job or activities

All team member fully understand job task the hazards that prepared by team leader which described in PTW & JHA.

crew know the job task

5.2 What is the purpose of Safety Morning Meeting

to ensure all ~~to~~ give ~~more~~ attention and take extra vigilant about work scope and potential hazard.

5.3 What is the purpose of briefing and Debriefing

- Briefing to what instruction, guidance and warning before going out on a mission. Receive

- debriefing refers to the process of receiving your report and narration of experience explanations for deviations form

5.4 What is Permit To Work (PTW)

To apply task/job for today on work site

- to protect worker and fellow worker
- responsibility, established guideline are followed.

5.5 Explain what do you understand from Job Safety Analysis and how does this help you to be safe?

technique to identify the dangers of specific task in order to reduce the risk of injury to worker

help reduce or eliminate them before anyone get hurt.

5.6 What are the safety precautions to be taken during tool maintenance at warehouse?

2.2 Same question



5.7 What are the safety precautions to be taken during topping up the fuel into Power Pack Tank?

- ✓ ensure the label of diesel is correct, Read MSDS and follow the instruction given.
- ✓ wear safety glasses, proper hand glove and mini platform due to power pack tank cap difficult to fill (Top up power pack)

5.8 What is work permit & why do we need them? *Some question*

Permit to work is mandatory and is system has been device to allow work to be carried out safely in onshore or offshore facilities if must clearly understand.

5.9 When do we apply the work permit

✓ we apply work permit after we get the programme from client and Job Task.

5.10 What are the safety precautions to be taken during test lubricator and BOP?

- ① announce all job onboard before test LUB and BOP
- ② Barricade the pressure area, ensure all the equipments which need to be test are valid in good condition and follow the sequences for pressure test.

5.11 What are the safety precautions to be taken during test Control Panel?

- ① checked hose condition is good
- ② Install whipcheck between air supply hose to control panel
- ③ barricade the work area.

5.12 Why JSA, Risk Assessment and Job Plan need to be discussed among the team member? How does that work?

- ① to ensure all team member involve with the task
- ② understand the task and know the hazards
- ③ remind them to used JSA, Risk assessment and Job plan
- ④ ensure all the task, performed complete with safety and know hazards will occurs when not comply.

5.13 While working, you found that there is something unsafe. What should you do?

- ① Apply stop work, inform supervisor/person in charge outside
- ② Discuss and tool. box talk about new hazard and safety precaution (recovery measure)
- ③ List in Job analysis



5.14 Before performing a hot work, what must you do/ have to ensure the work is safe

- ✓ Apply Hot work permit follows by JHA
- ✓ Put a signboard to prevent unauthorized person enter,
- ✓ always monitor out work site area to ensure in control
- ✓ eliminates hot work hazards and the worker risk.

Employee able to explained abt JHA, PTW and Hazard Identification but unable to explain little bit about the responsibilities of Others HSE. Overall good explanations. He have many answers but a bit lack when comes in explanations.

1. Please attach the supporting documents that you participated in Dimension Bid's Safety program.

a) Job Safety Analysis for each activity that you involve during probation period

- Chipping
- Painting
- Lifting
- Spooling
- Pressure Test

b) Hazard Hunt

c) Safety Talk

B. SURFACE EQUIPMENT

1. Stuffing Box

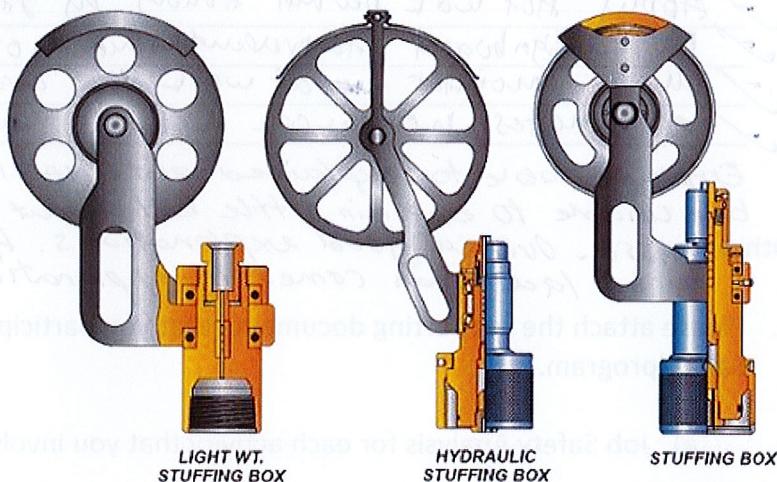

What is Stuffing Box

- The main seal on the wire
- Primary Barrier

What is the purpose of stuffing Box

to ensure sealing off around moving or stationary solid wireline at the upper end to the lubricator

How to operate Stuffing Box

- The line size determines the size of the "upper gland", lower gland and sheave diameter.
- 0.092" line diameter is 10"
- 0.108" line diameter is 15"

What is maintenance required for Stuffing Box

- ① upper gland
- ② packing
- ③ lower gland
- ④ plunger stop
- ⑤ BOP plunger

What is safety precaution required for Stuffing Box

- check packing
- check the sheave size
- check upper and lower brass packing gland
- check sheave bearings
- check alloy side arms for damage from side play in sheave wheel
- check BOP plunger

What is potential hazard during handling Stuffing Box

- ① Back Pain
- ② Drop
- ③ Pinch Point

Draw & name each part of stuffing box

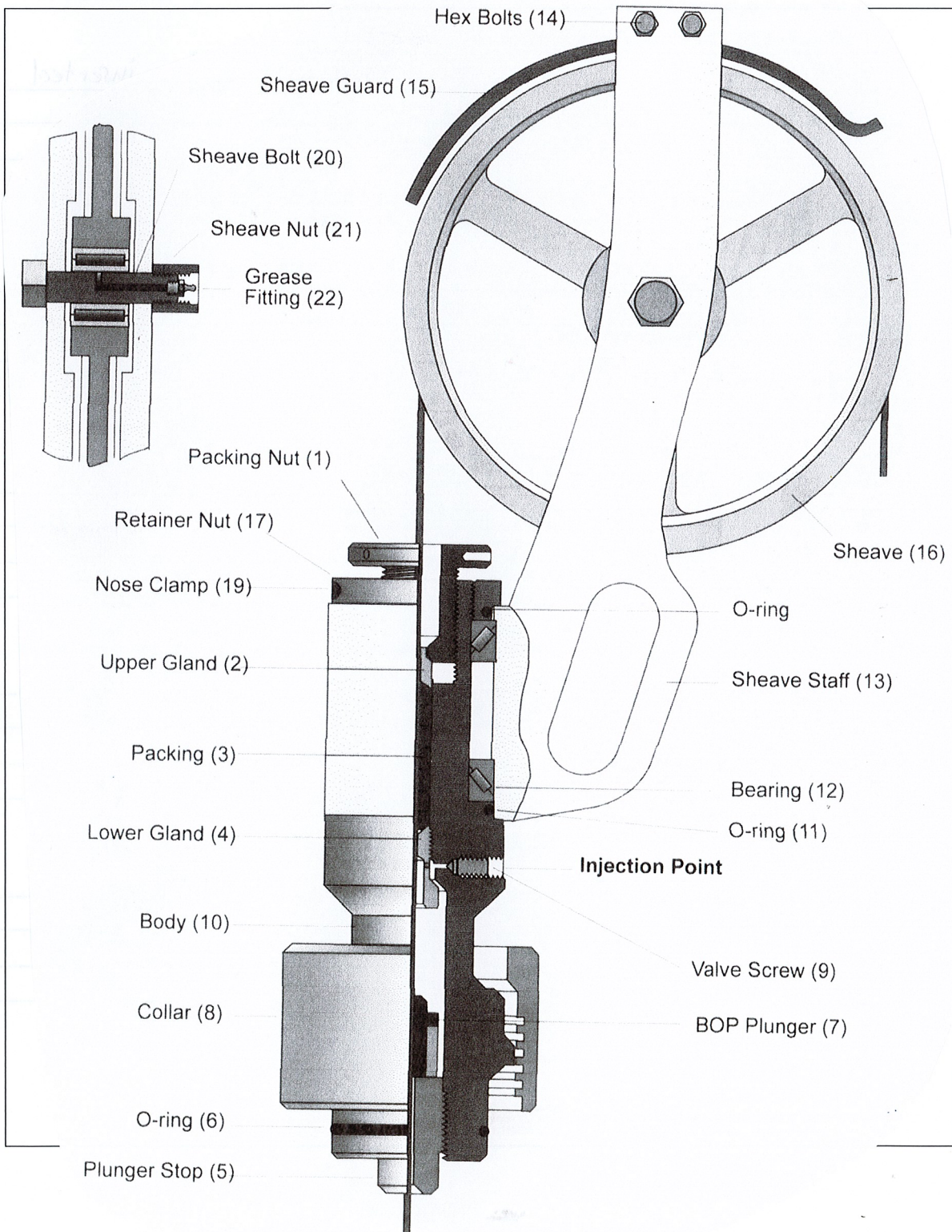



2. Lubricator

What is Lubricator

- To keep hydro carbon inside the lubricator when connect the well head string

What is the purpose of Lubricator

- enable wireline toolstring and equipment to be inserted and removed from well under pressure.

How to operate Lubricator

- manual lifting with both hand,
- must be 2 person to carry
- put the o-ring to make metal to metal seal
- Tighten the collar after connect with other connection same size with that

What is maintenance required for Lubricator

- X-rayed, magnifluxed for cracks
- visually inspected at regular intervals
- Hydro test, High pressure and low pressure

What is safety precaution required for Lubricator

- Inspection - NDT
- MPI - Hydrotest
- Hardness test
- wall thickness test

What is potential hazard during handling Lubricator

- ① Back pain
- ② Drop
- ③ pinch point



Draw & name each part of Lubricator



Slimline Lubricators (ported)

Lightweight Lubricators (ported)



3. Blowout Preventer (BOP)

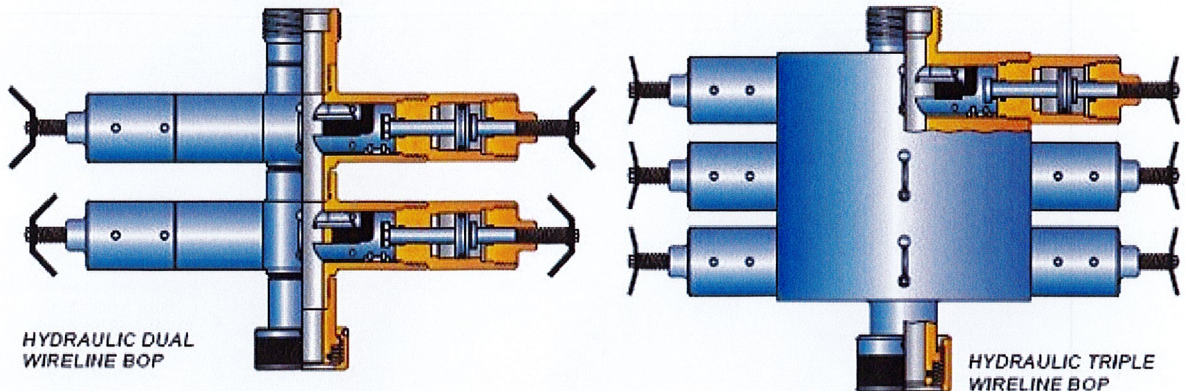

What is BOP

- Blowout Preventer is safety equipment that can close around the wireline and seal off the well below it.

What is the purpose of BOP

- to enable the well pressure to be isolated without cutting the wire
- to permit the assembly of the wireline cutter above the BOP ram
- to permit the dropping of a wireline cutter if the tool string becomes stuck in the well

How to operate BOP

- check BOP open & close position
- pressure test the ram to ensure inner seal hold pressure
- connect hose to power pack and control at the RCU

What is maintenance required for BOP

- change inner seal, outer seal
- check inner seal locking screw
- check centraliser

What is safety precaution required for BOP

- Function test the ram BOP, open & close position
- make sure no hydraulic oil leak from hose connection



What is potential hazard during handling BOP

- pinch point
- Drop

Draw & name each part of BOP

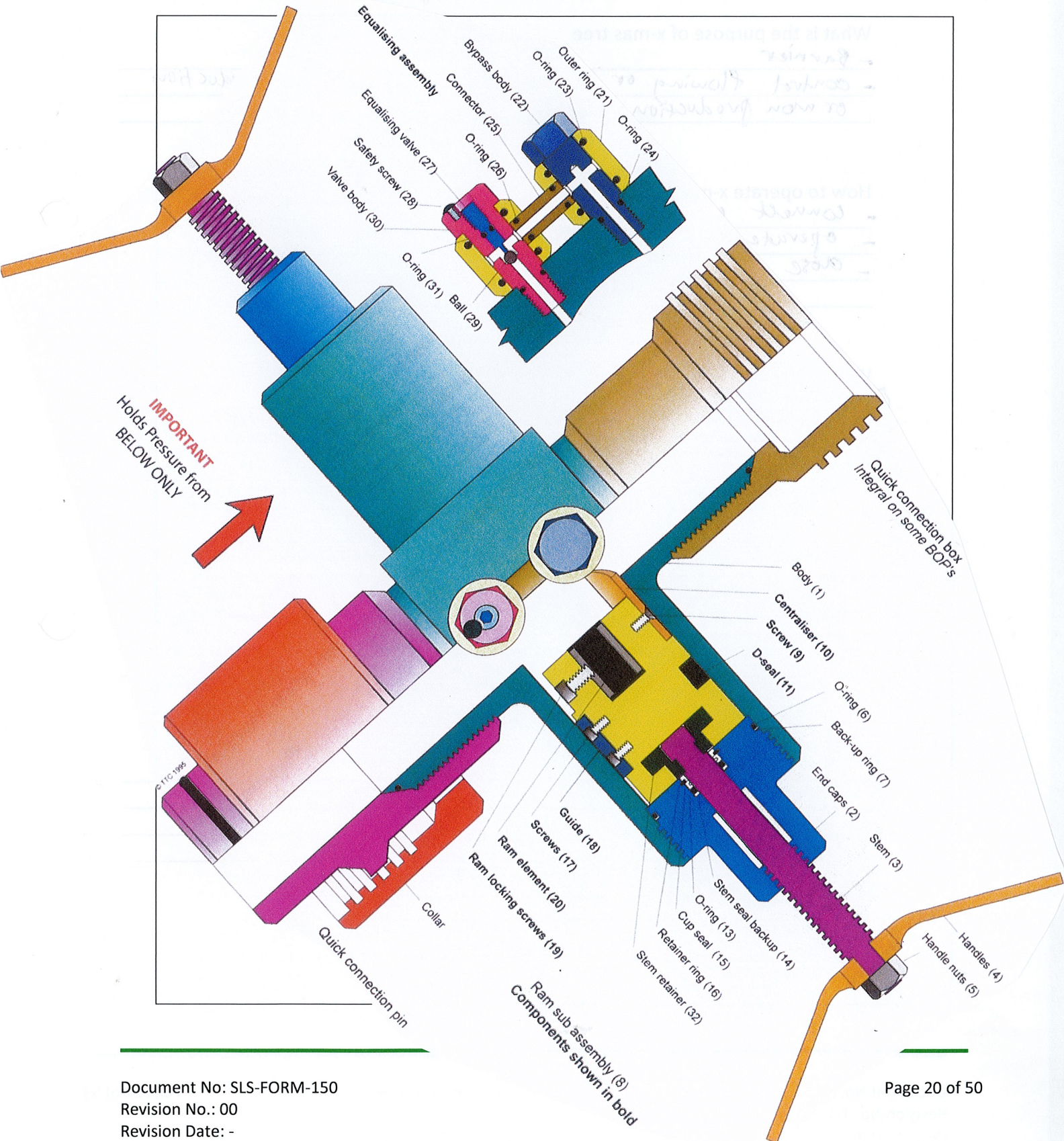



4. X-Mas Tree

What is x-mas tree

valve installation the wellhead to control
flow of fluids from the well

What is the purpose of x-mas tree

- Barrier
- control flowing or injection gas/oil on a production or non production well

How to operate x-mas tree

- connect control line for rxv to scssv
- operate the swab/crown valve
- close flow line and wing valve

What is maintenance required for x-mas tree

- ① two-way check valve
- ② wireline retrievable tubing hanger plug
- ③ vk-plug

What is safety precaution required for x-mas tree

- do not over-tighten while open and close
- count the swab/crown valve while turn open and close

What is potential hazard during handling x-mas tree

- ① pinch point
- ② drop object
- ③ suspended load
- ④ line of fire



Draw & name each part of x-mas tree

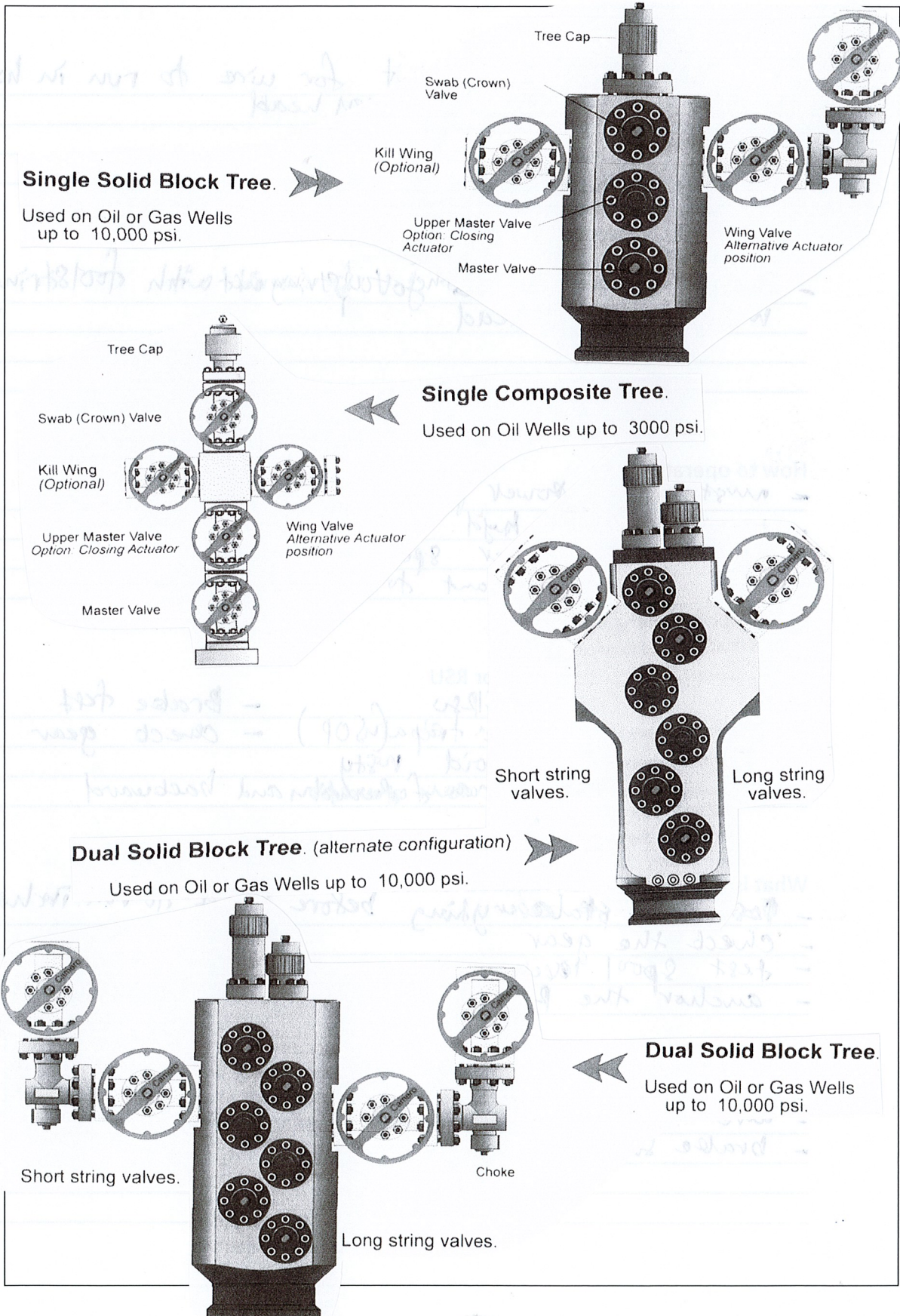



5. Wireline Reel Skid Unit (RSU) / Winch – Single Drum and Double Drum

What is RSU

- ~~Reel~~ Reel Skid Unit for wire to run in hole
the footstring inside the well head

What is the purpose of RSU

- For slickline do a job connect with footstring
inside the well head

How to operate RSU

- must have power pack
- connect the hyd hose to power pack
- operate the lower spool in and out
- used brake if want to slow down or emergency
to stop

What is maintenance required for RSU

- Service the RSU - Brake feet
- Check the main chain - check gear 1-4
- Painting for avoid rusty
- Test Spool forward if can function and backward

What is safety precaution required for RSU

- Double check everything before start to run in hole
- check the gear
- set spool
- anchor the RSU to prevent moving when run in hole

What is potential hazard during handling RSU

- wire tension
- brake suddenly not holding



Draw & name each part of RSU

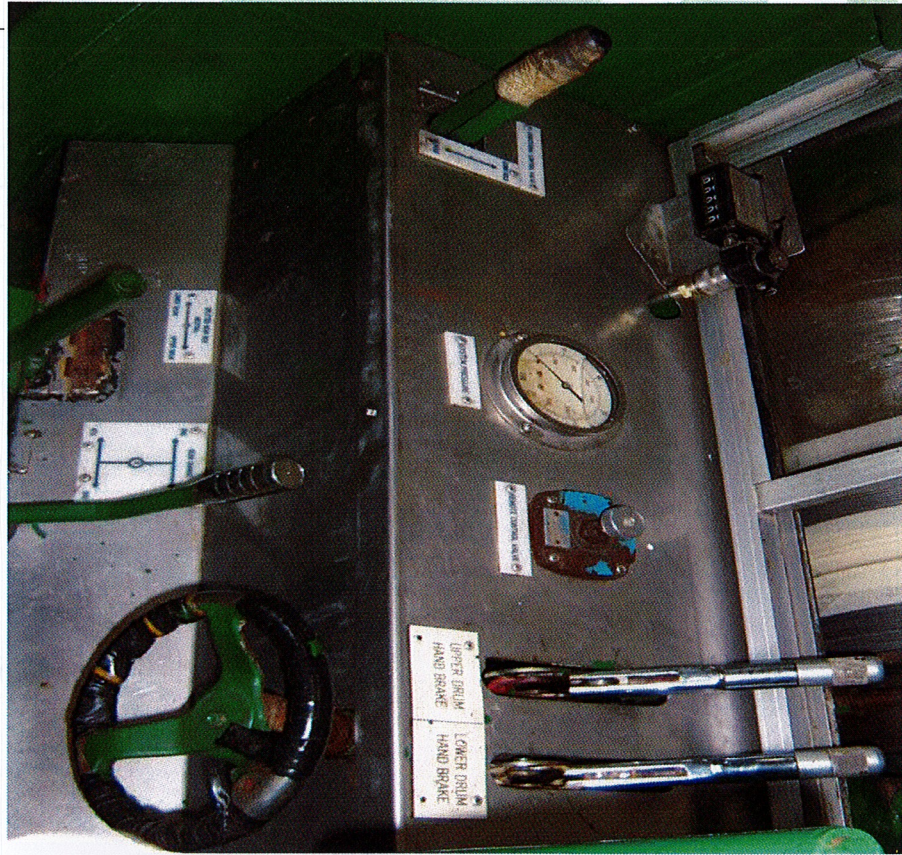

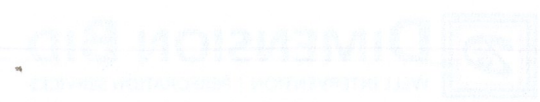

6. Odometer

What is Odometer

- measuring the distance

What is the purpose of Odometer

- count the length of wire
- to see the feet depth

How to operate Odometer

- connect cable to angle drive
- try spool out 3' in the wire if odometer can rolling the number

What is maintenance required for Odometer

- greasing on bearing
- clean the cable with anti-frost (WD 40)

What is safety precaution required for Odometer

- always monitor the number rolling in correct counting
- out of depth count
- make to test

What is potential hazard during handling Odometer

- jammed pins
- depth counting out
- jumping number



Draw & name each part of Odometer

What is the purpose of weight indicator?

- to know the level of the well
- to know the level of the well

How to operate weight indicator?

- attach to the well
-

What is maintenance required for weight indicator?

- back cell
-

What is the purpose of weight indicator?

- to keep well at the base
-

What is the purpose of weight indicator?

-
-

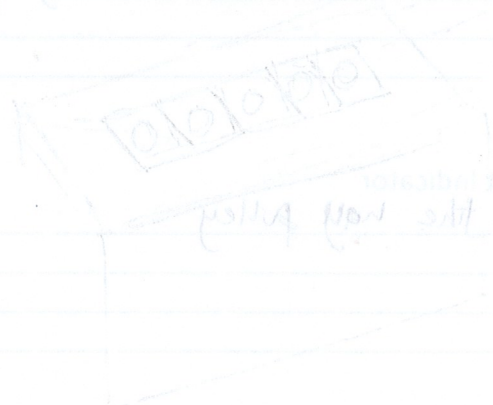



7. Weight indicator (200 lbs and 4000 lbs)

What is Weight Indicator

- to indicate toolstring weight

What is the purpose of Weight Indicator

- to know toolstring weight
- to know the limit for every job when to pull test

How to operate Weight Indicator

- attach to the way pulley

What is maintenance required for Weight Indicator

- load cell gap
- calibrate weight indicator gauge

What is safety precaution required for Weight Indicator

- no leak oil at the hose
- care the indicator glass, don't crack

What is potential hazard during handling Weight Indicator

- pinch point
- leaking



Draw & name each part of Weight Indicator

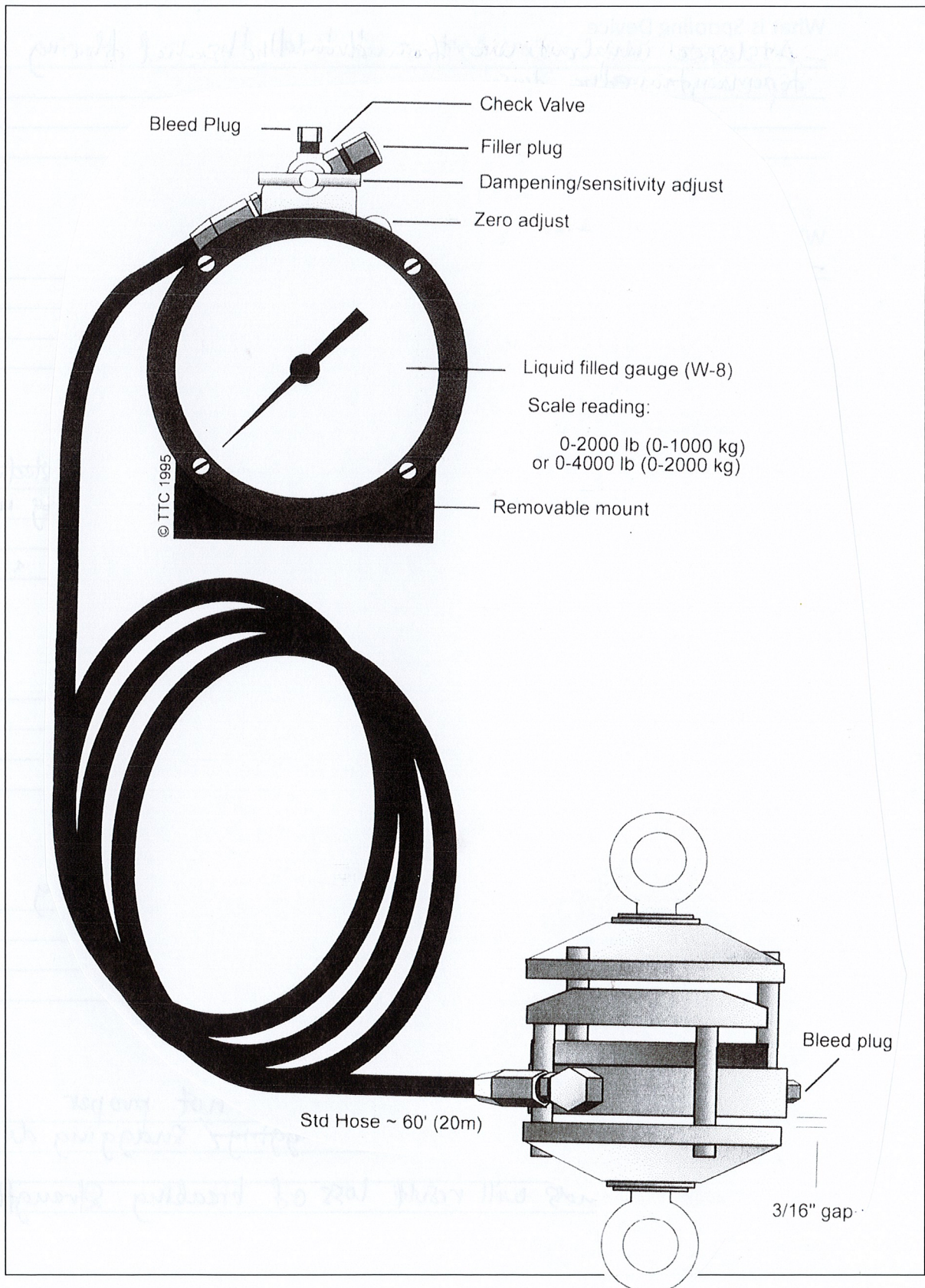



8. Spooling Device

What is Spooling Device

A device which convert and hold the reel during spooling

What is the purpose of Spooling Device

- to spool in & out wire from drum
- to maintain the wire tension

How to operate Spooling Device

- Hydraulic source from open loop hydraulic powerpack. The unit has a hydraulically driven motor on which the new drum (shipping drum) is placed.
- Hydraulic tension during spooling is controlled from a control panel mounted on the side of the unit.

What is maintenance required for Spooling Device

- Brake system
- Lever
- Gear

What is safety precaution required for Spooling Device

- make sure gear is free before start spooling
-

What is potential hazard during handling Spooling Device

- Reel damage can cause spooling result not proper
- Variable tension can cause snagging during re-winding
- Loops and bends will result loss of breaking strength



Draw & name each part of Spooling Device

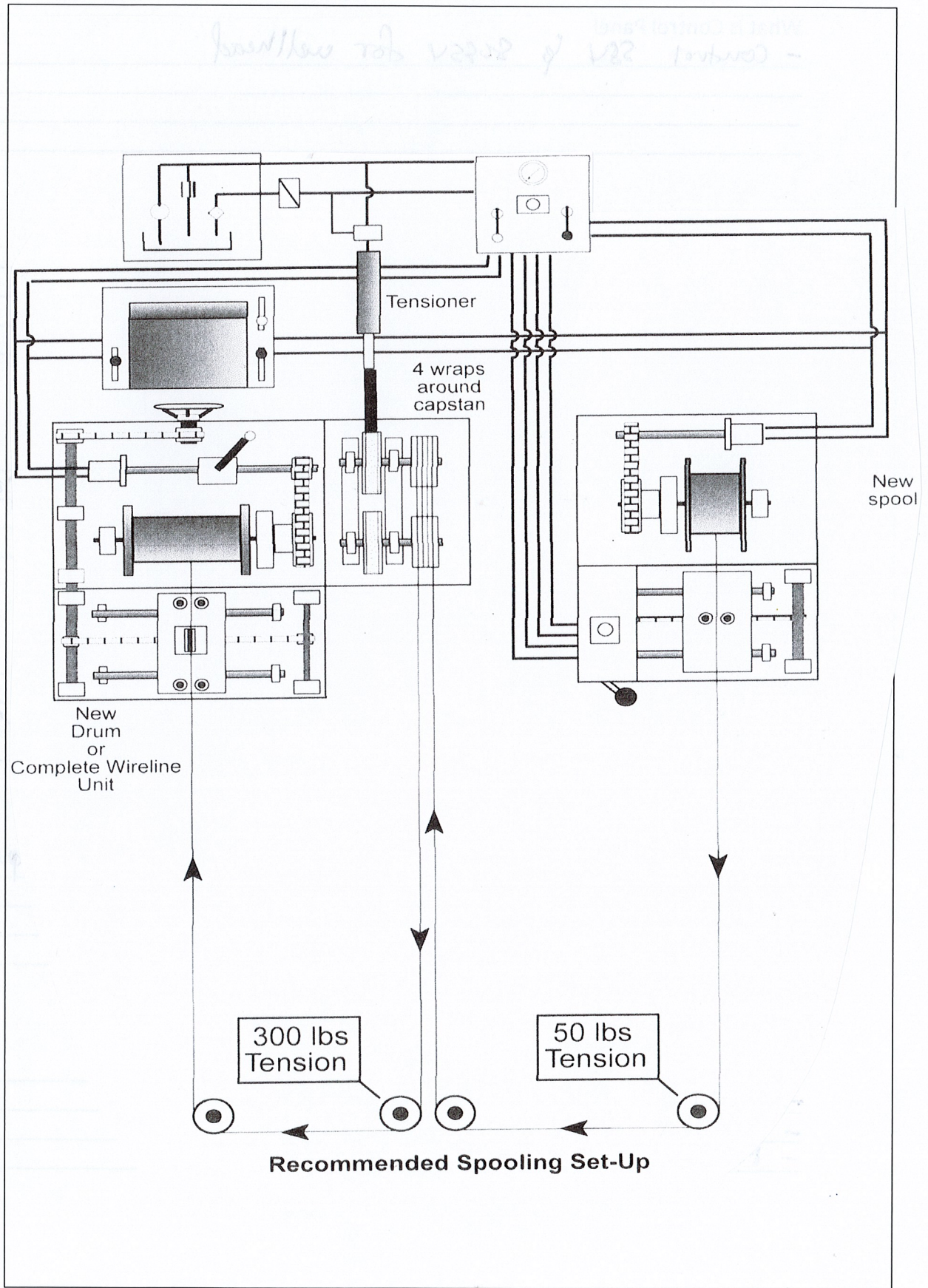



9. Control Panel

What is Control Panel

- Control SSV & SCSSV for wellhead

What is the purpose of Control Panel

- for emergency stop the pressure come out
- to secure wellhead

How to operate Control Panel

- connect air supply
- set the pressure for SSV & SCSSV for open position

What is maintenance required for Control Panel

- test regulator
- test hold pressure if no leak
- monitor pressure gauge if pressure no dropping

What is safety precaution required for Control Panel

- always monitor the pressure gauge if already pump
- make sure regulator can hold pressure

What is potential hazard during handling Control Panel

- can cut the wire while on in hole
- wellhead cannot secure
- leaking at control line
- relief valve damage

Draw & name each part of Control Panel

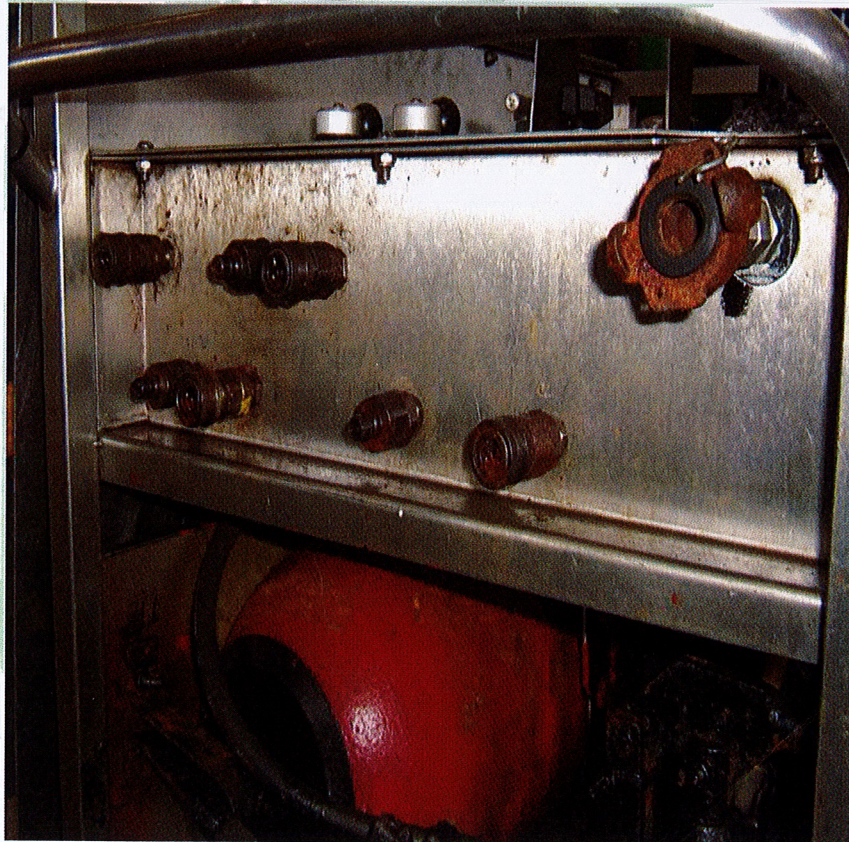
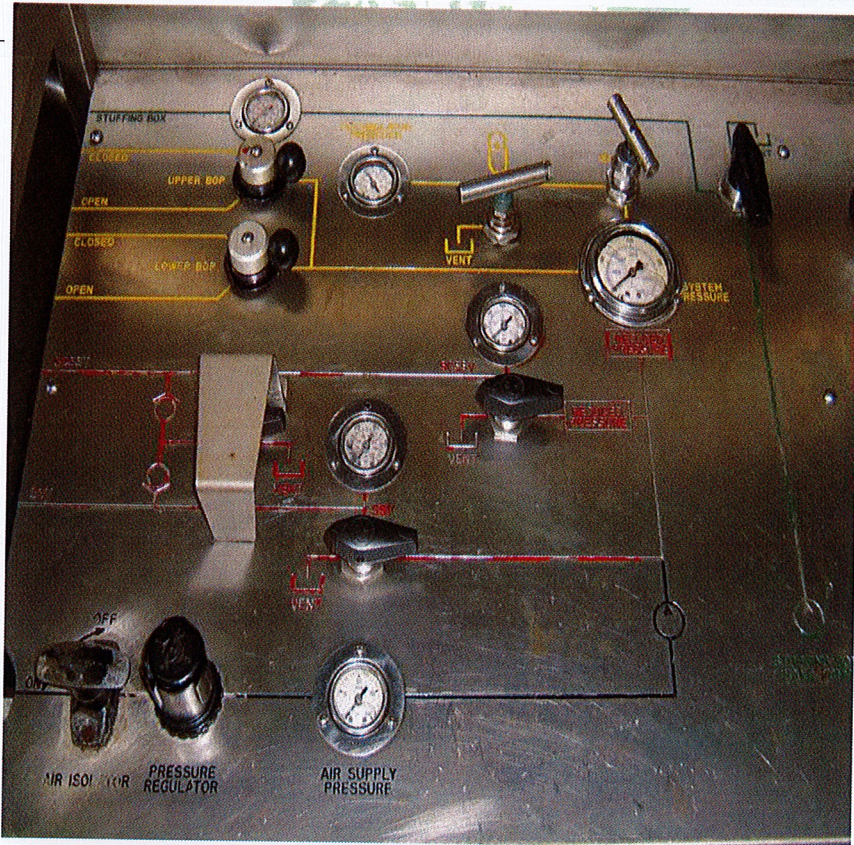



10. Huskel Drum

What is Huskel Drum

- Designed for safe, reliable, and economical source of hydraulic pressure

What is the purpose of Huskel Drum

- connect compressor air to hydraulic power satisfying any application needs for pressurizing up a component and holding it at a pressure for any sustained period of time

How to operate Huskel Drum

- automatically reciprocate on different piston principle.
A large piston driven by relatively low pressure drive acts directly upon a smaller hydraulic piston.

What is maintenance required for Huskel Drum

- Gas booster should be reser load for 500 - 1000 hours of over 15 month
- huskel drum system

What is safety precaution required for Huskel Drum

- Do not pump flammable or corrosive liquid such as gasoline or acid.

What is potential hazard during handling Huskel Drum

- mechanical seal failures
- Reduced or low flow in certain fogel pumps
- over pressurization
- High temperature



Draw & name each part of Huskel Drum

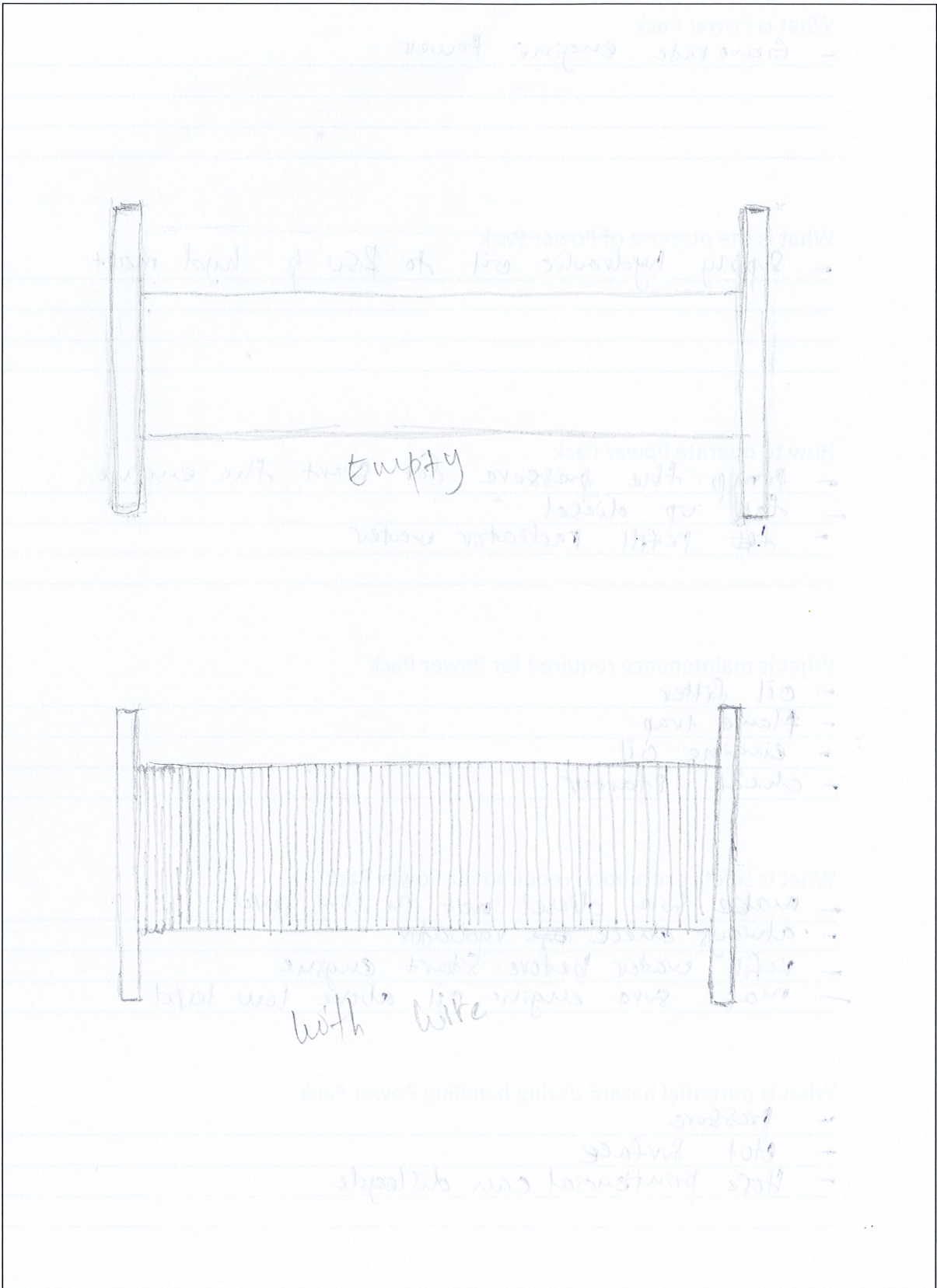



11. Power Pack (Electrical & Diesel)

What is Power Pack

- Generate engine power

What is the purpose of Power Pack

- Supply hydraulic oil to PSU & hyd mast

How to operate Power Pack

- Pump the pressure for start the engine
- top up diesel
- refill radiator water

What is maintenance required for Power Pack

- oil filter
- flame trap
- engine oil
- check starter

What is safety precaution required for Power Pack

- make sure diesel not in low level
- always check the radiator
- refill water before start engine
- make sure engine oil above low level

What is potential hazard during handling Power Pack

- pressure
- hot surface
- hose potential can dislodge



Draw & name each part of Power Pack

[Handwritten notes on lined paper, including a drawing area and text:]

What is the purpose of Air Compressor?

- to supply air for our control panel / pump
- open loop hydraulic system

What is the purpose of Air Compressor?

- to operate the pump
- to operate the pump
- to operate the pump

What is the purpose of Air Compressor?

- to operate the pump
- to operate the pump
- to operate the pump

What is the purpose of Air Compressor?

- to operate the pump
- to operate the pump
- to operate the pump

What is the purpose of Air Compressor?

- to operate the pump
- to operate the pump
- to operate the pump

What is the purpose of Air Compressor?

- to operate the pump
- to operate the pump
- to operate the pump



12. Air Compressor

What is Air Compressor

- Open loop hydraulic system unit

What is the purpose of Air Compressor

- to supply air for air control panel / sweep

How to operate Air Compressor

- use Spring Starter to operate
- Rotate the shaft clockwise until red indicator
- Release the Spring to start

What is maintenance required for Air Compressor

- air inlet shut down valve
- inspect for cleanliness or damage

What is safety precaution required for Air Compressor

- shut down valve set at 1800 rpm
- low engine oil pressure set at 20 psi
- Coolant temperature set at 95°
- high exhaust temperature set at 200°

What is potential hazard during handling Air Compressor

- pinch point
- Back injury
- Hot surface



Draw & name each part of Air Compressor

What is the purpose of Oil
- Shore & replace wire

Do the right and wrong with attachment from first to last policy

Right Method

Wrong Method

What is maintenance required for Drums
- Check drum pressure
- Check drum level and

What is safety procedure required for Drums
- A clamp first or "tag knot" used to secure connector line
- do the seal
- put 2 to 3 wraps of line on the reel to ensure
- that wire not free

What is potential hazard during handling Drums
- overexertion
- back strain



13. Drum

What is the purpose of Drum

- Store slickline wire

Do the right and wrong wire arrangement from drum to hay pulley

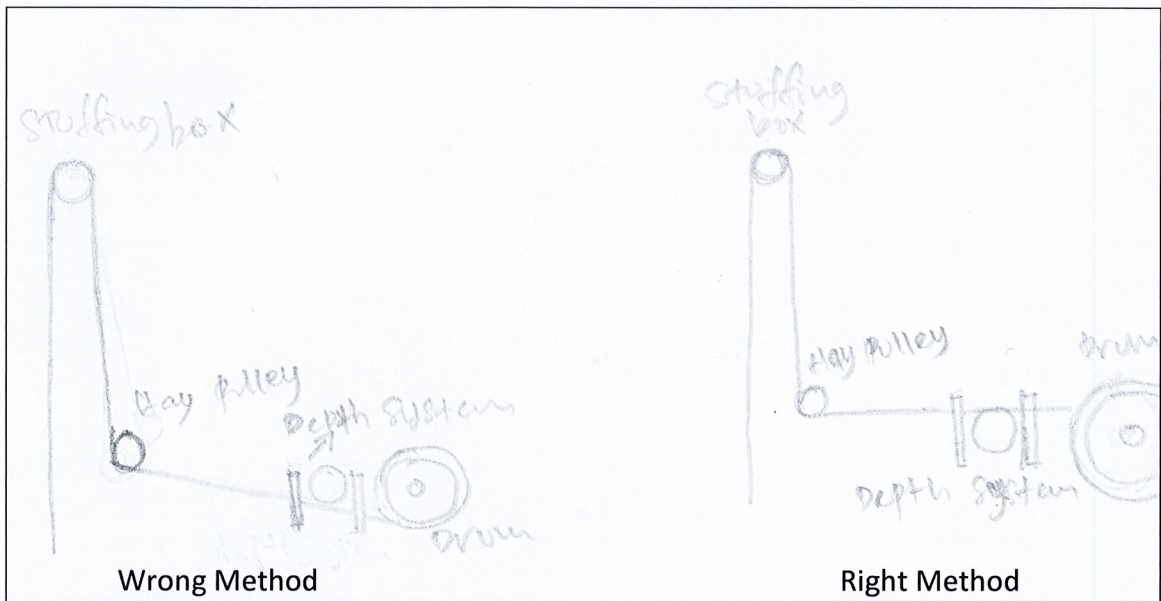

What is maintenance required for Drum

- check drum brake
- check drum lever and

What is safety precaution required for Drum

- A clamp bust or "dog knot" used to secure conductor line to the reel
- Put 3 to 5 wraps of line on the reel to ensure knot does not free

What is potential hazard during handling Drum

- uneven winding
- Fatigue cracks

Please draw/sketch the toolstring configuration for:

- 1) Drift run/tubing clearance check
- 2) Sinker bar run
- 3) Set and retrieve plug
- 4) Set and retrieve insert valve

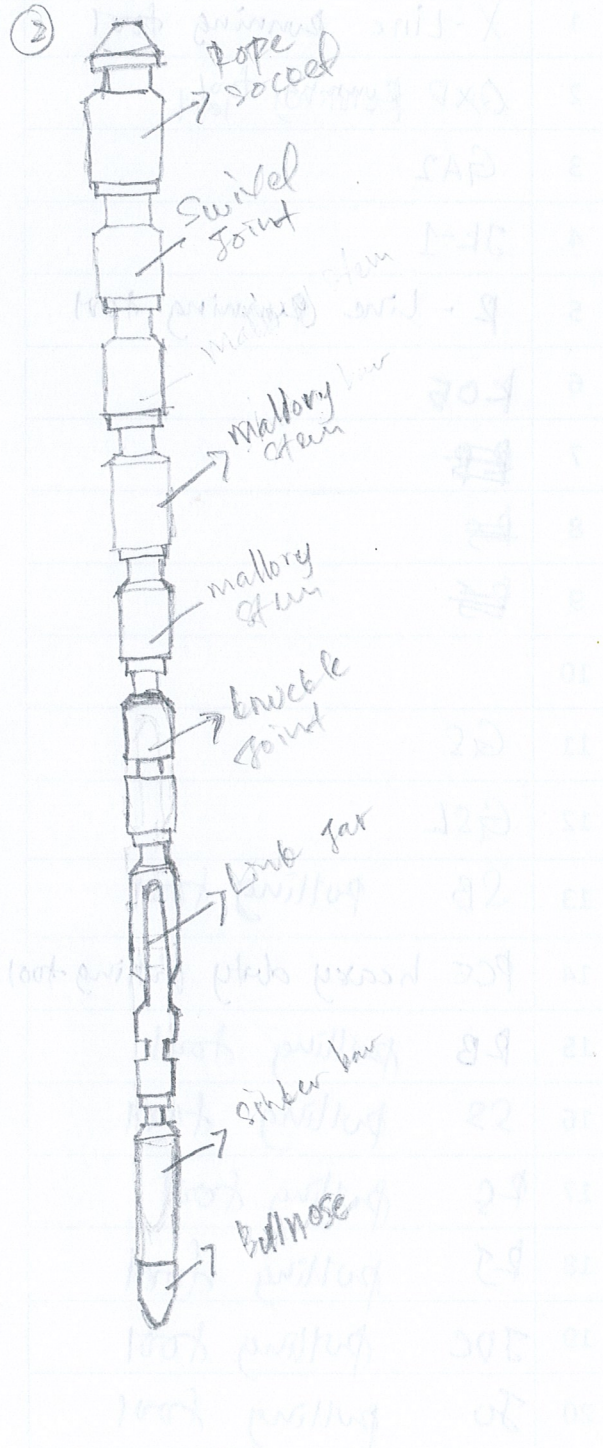
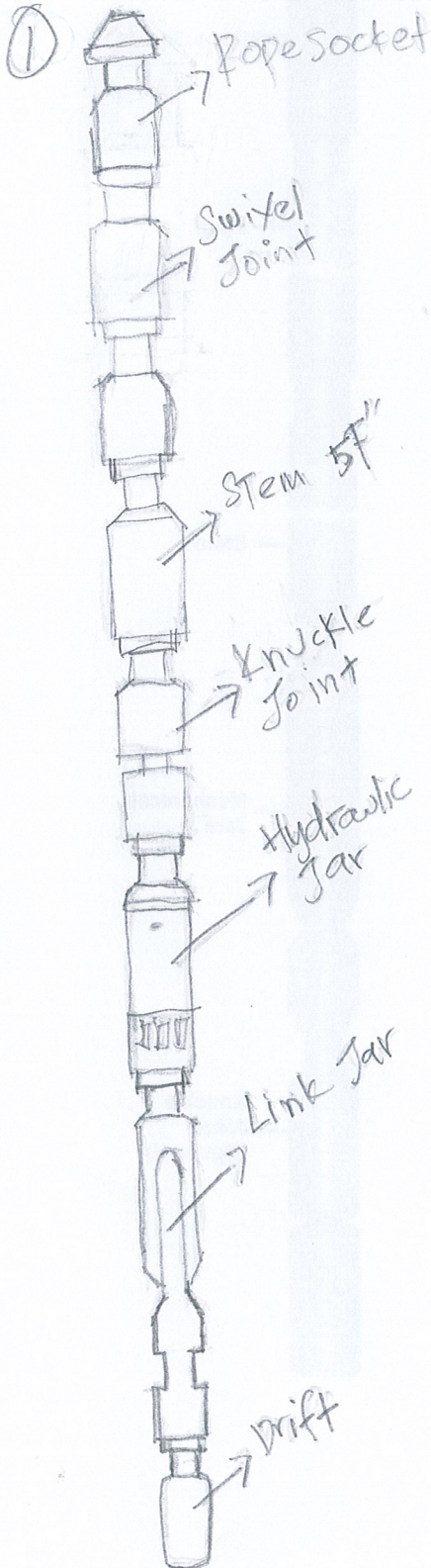



C. DOWNHOLE EQUIPMENT

1. List out all basic running and pulling tools

No.	Items
1	X-Line Running tool
2	OXD Running Tool
3	GA2
4	JK-1
5	P-Line Running tool
6	K05
7	
8	
9	
10	
11	GS
12	GSL
13	SB pulling tool
14	PCE heavy duty pulling tool
15	RB pulling tool
16	SS pulling tool
17	RS pulling tool
18	RS pulling tool
19	JDC pulling tool
20	Ju pulling tool

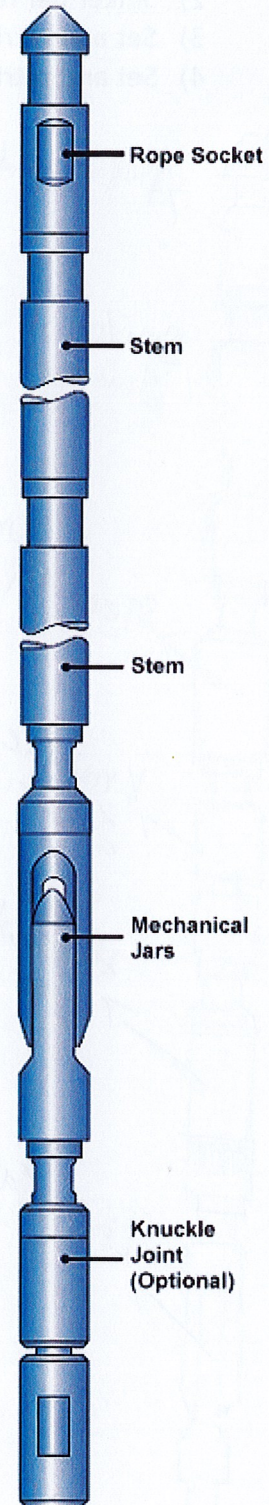



Primary Wireline Tool-string

Tool-string configuration according to requirement. Introduction to

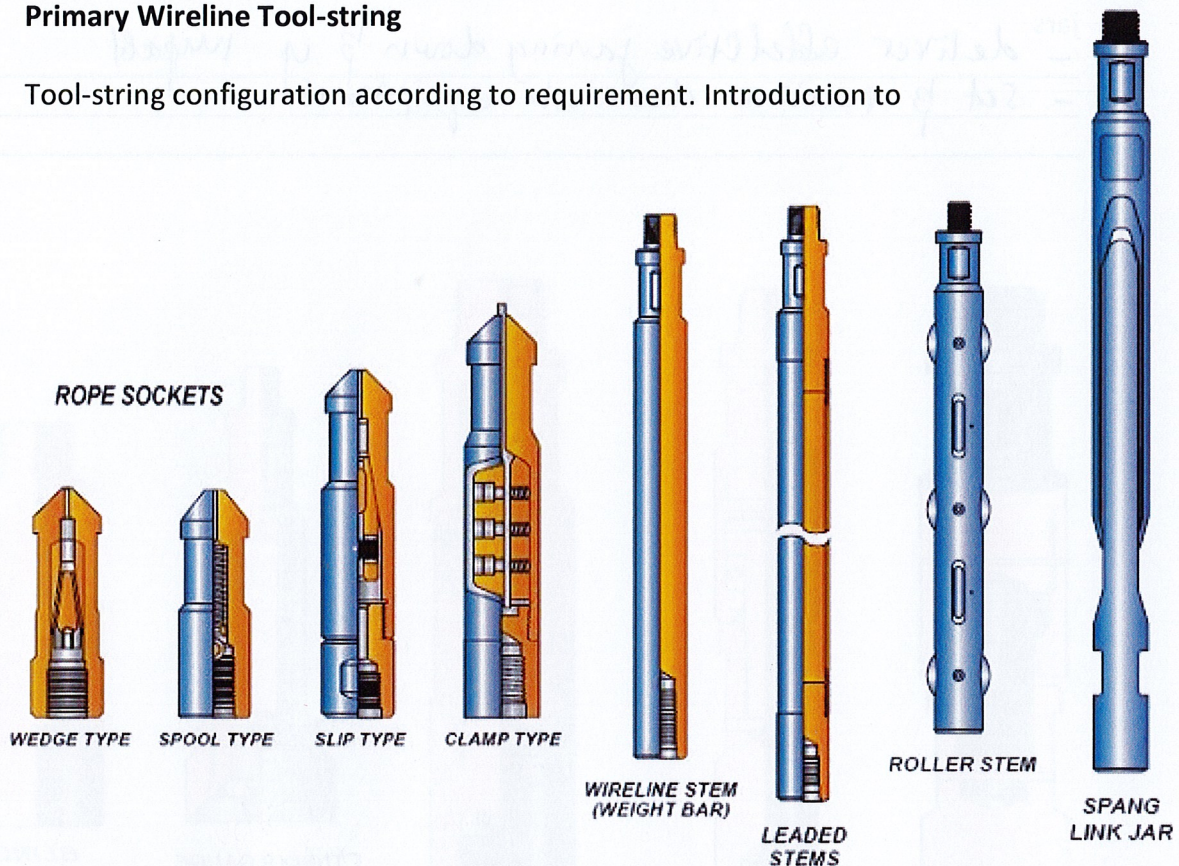

- a) rope sockets
- used to make the connection between the stickline and tool string
- b) stem lead
- used to provide additional weight to the tool string which may be required to run into the well bore against high pressure & stuffing box friction.
- c) tungsten stem
- heavy than normal stem
- to make more impact for jar down and jar up
- d) roller stem
- reduce friction against tubing wall
- to make tool string easy pass through down hole
- used for work on deviated wells



- e) jars
- deliver effective jarring down by up impact
 - set by retrieve downhole equipment

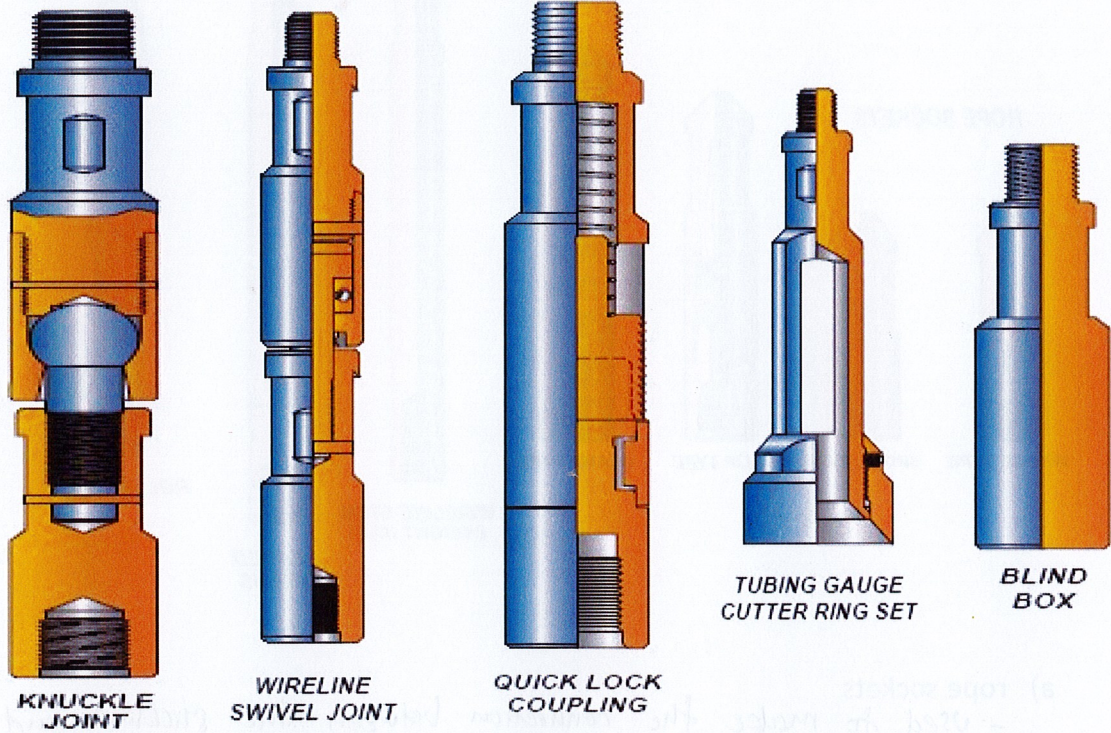

- f) knuckle joints,
- to add flexibility to the tool string and used in deviated well
 - easy for 45° of sideways movement

- g) swivel joints,
- minimize effect of wire twisted
 - double fishing neck

- h) quick-lock coupling
- used instead of the threaded type
 - no need pipe wrench



- i) gauge cutter,
- to clear hard wax and scale that stick at the tubing wall
- clear the way inside tubing before run drift.
- j) Blind Box
- to cut wire on top rope socket
- used when heavy downward jarring is required to dislodge a fish or push tool down hole.

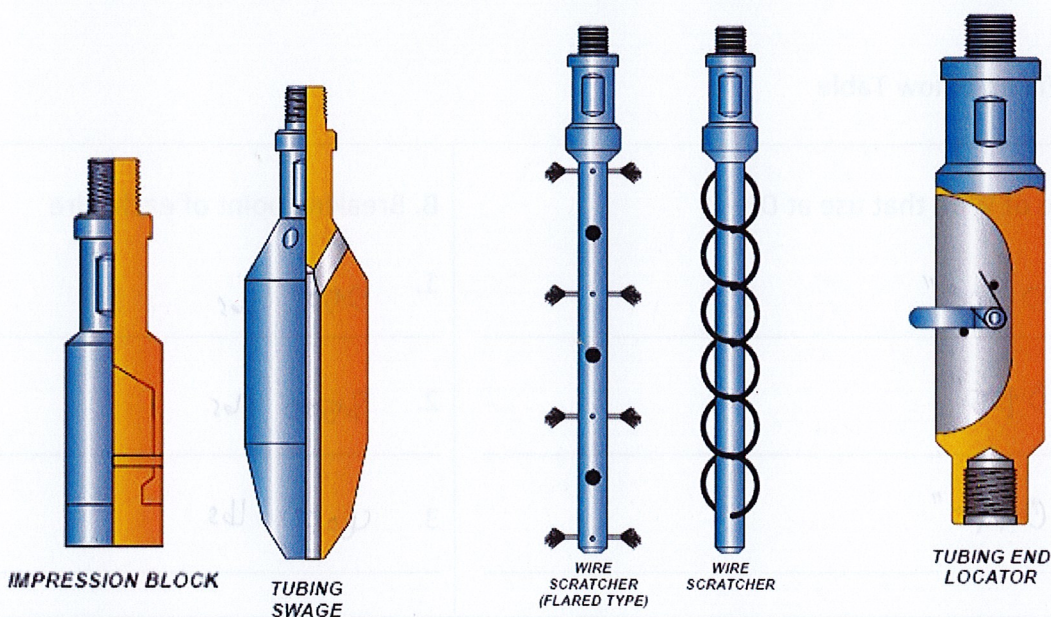

- k) lead impression box
- to obtain an image profile of a wide range of equipment downhole to be latched or fished
- l) swage
- used to clear minor restriction caused by light collapse in the tubing string
- m) wire scratcher
- used to dislodge scale, salt, paraffin
- can be used to fish small piece of wireline lying loose
- locate ripples, side pocket mandrels (SPM)



n) tubing end locator

- Identify the end of production tubing
- to locate the end of tubing when running the completion
- check hold up depth (HUD)
- can be used plugged back total depth (PBDT)

o) wire recover tool

-

Fill up below Table

<p>A. Size of Wire that use at DB</p> <ol style="list-style-type: none"> 0.108" 0.125" 0.140" 	<p>B. Breaking point of each wire</p> <ol style="list-style-type: none"> 2500 lbs 3500 lbs 4050 lbs
<p>C. Type of wire used at DB</p> <ol style="list-style-type: none"> EIPS ZEPON ZAPP 	<p>D. How to test if wire is good or not</p> <ol style="list-style-type: none"> Tension testing Tensile testing Durability test
<p>E. Why do we need to check on the tools before running in hole (RIH)?</p> <ul style="list-style-type: none"> - prevent dislodge - to ensure all part are tighten 	



F. What do we need to do if the tool is damage or lost in hole?

- Report to Town (CDB office or workshop)
- Ask for suggestion from dedicated steering personnel
- Troubleshoot the problem, depend on situation and tools

G. What do we need to do if equipment failed to work?

- Report to town, ask for suggestion
- Communicate with supervisor onsite for replacement
- Troubleshoot the equipment



D. Rig up Wireline Surface Equipment

a. List out all surface equipment (Surface and Pressure Gauge)

1.	Power Packer
2.	Air compressor
3.	Reel stand unit (RSU)
4.	Hydraulic mast
5.	Hydro test pump
6.	SWEP
7.	Recorder chart
8.	Weight indicator
9.	Load cell
10.	Genset
11.	Tools box
12.	Lubricator stand set
13.	BOP

b. Describe how to connect lubricator section

i) Horizontal

- using stand and trolley

ii) Vertical

- Align pin to bore perfectly and put some grease on the O-ring to prevent O-ring damage



Note: Provide drawing and parts description on separate paper/page

c. Sketch the equipment required while rigging up from x-mas tree until stuffing box

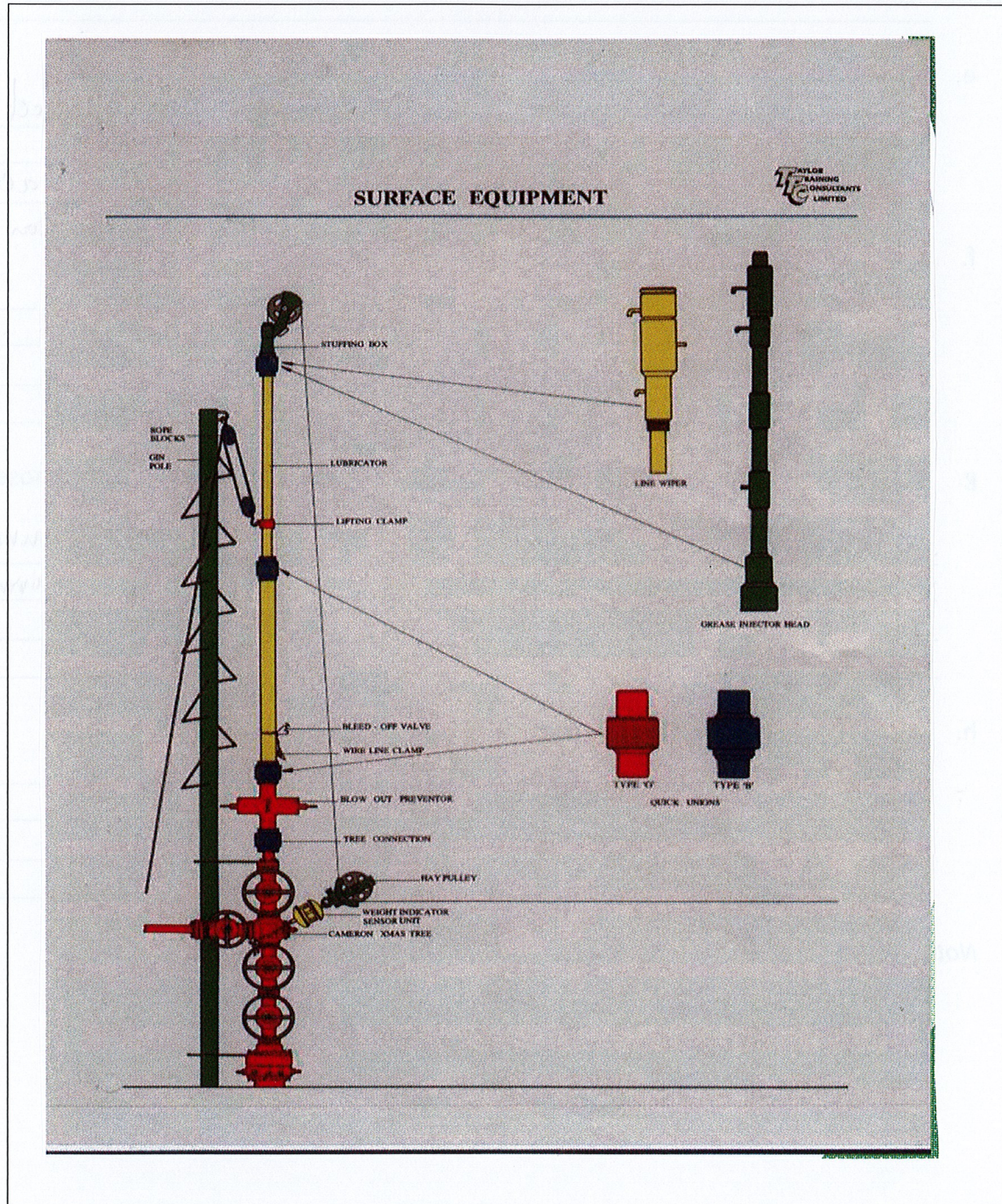

Note: Provide drawing and parts description on separate paper/page



d. What should weight indicator attached with?

- Weight Indicator attached on unit
- Load Cell attached with key (key)

e. What is the meaning of rigging up and rigging down?

- Rigging up - assemble ~~out~~ ^{over} PCE and ready to attached on well head (Christmas tree)
- Rigging down - disconnect ~~over~~ ^{over} PCE attached on well head when ~~over~~ ^{over} job is done
- also if have ~~leaking~~ ^{leaking} or PCE connection

f. What is power pack hose size used at Dimension Bid?

- Return - 1 1/4"
- Supply - 1"

g. What are the safety precautions required upon completed hook up hydraulic hose to RSU

- make sure release pressure inside the hose before connect
- make sure proper lock the connection before running

h. List out the safety precaution while rigging up and rigging down

Note: Provide drawing and parts description on separate paper/page



DIMENSION BID

WELL INTERVENTION | PERFORATION SERVICES

VERIFICATION

I hereby verify that the above paperworks and documents above has been checked and confirmed true.
I further certify that all information contained herein is true and accurate.

I understand that any falsifying of any document above could result in disciplinary action and being denied access to Training & Development System in future.

PREPARED AND SUBMITTED BY

SIGNATURE
NAME:

POST:

DATE:

ENDORSEMENT

All check points listed above have been verified completed by myself or my delegates.

I deem that this document can be use for Training & Development System support document.

VERIFIED BY

SIGNATURE
NAME:

POST:

DATE:



DIMENSION BID

WELL INTERVENTION | PERFORATION SERVICES

Job Track Record

NAME: Aubrey Andrew Bernard	
DESIGNATION: Assistant 3	
EXPERIENCE:	
NATIONALITY: Malaysia	NRIC NO/PASSPORT.: 860416-12-5289
MARITAL STATUS: Married	AGE: 33
ACADEMIC QUALIFICATIONS:	
SKILL PROFILES:	<u>TECHNICAL TRAINING</u>
WORKING EXPERIENCE:	
CURRENT DUTIES AND RESPONSIBILITIES:	
<p><u>JOB DESCRIPTION:</u></p> <p><u>Safety</u></p> <p><u>Operations</u></p> <p><u>Quality and Standards</u></p> <p><u>Planning</u></p> <p><u>Training and Support</u></p>	



DIMENSION BID

WELL INTERVENTION | PERFORATION SERVICES

Job Profile				
Years	Client	Month	Well	Services
2019	SEAH	Jun	SJ 804L	Set Separation
2019	SEAH	July	SJ 810A	Wax cut
2019	SEAH	July	"	FXE Rectification
2019	SEAH	"	SJ 810B	Set Mox Valve
2019	"	August	SJ 804L	- Retrieve Separation - close SSP - open SSP zone 5 zone 4
2019	"	"	SJ 809B	- set separation wax cut
2019	"	Sept	SJ 702N	wax cut
2019	"	"	SJ 704L	wax cut
2019	"	"	SJ 707N	wax cut



DIMENSION BID

WELL INTERVENTION | PERFORATION SERVICES

Job Track Record

NAME: AUBREY ANDREW BERNARD	
DESIGNATION: Slickline ASSISTANT 3	
EXPERIENCE: 9 YEARS	
NATIONALITY: MALAYSIA	NRIC NO/PASSPORT.: 860416-12-5289
MARITAL STATUS: MARRIED	AGE: 35
ACADEMIC QUALIFICATIONS: SPM	
SKILL PROFILES:	<u>TECHNICAL TRAINING</u>
WORKING EXPERIENCE:	
CURRENT DUTIES AND RESPONSIBILITIES:	
<p><u>JOB DESCRIPTION:</u></p> <p><u>Safety</u></p> <p><u>Operations</u></p> <p><u>Quality and Standards</u></p> <p><u>Planning</u></p> <p><u>Training and Support</u></p>	

