

Technical Manual

INCLUDING:

Safety Manual
Operation Manual
Maintenance Manual
Storage Instructions

FOR:

Assembly Number	Description
11183600-0013	3.600in Guide Roller Bogie

Important Notes

All of the equipment referred to in this technical manual is designed and manufactured by Wireline Engineering Ltd in Scotland, UK. Wireline International LLC is a wholly owned subsidiary of Wireline Engineering Ltd

The ROLLER BOGIE™ tool designs are protected by international Patents.

The ROLLER BOGIE™ trademark is an internationally registered trademark.

The WELLBOSS™ trademark is an internationally registered trademark

This document is the property of Wireline Engineering Ltd and must not be used, reproduced or disclosed to any third party without prior written approval from Wireline Engineering Ltd.

Wireline Engineering Ltd
 Technology House
 Blackburn Business Park
 Blackburn
 Aberdeen
 Scotland - UK
 AB21 0PS
 Telephone: 01224 798000
 Facsimile: 01224 791410
www.wireline-engineering.com

Wireline Engineering LLC
 1406 West Pinhook Road
 Lafayette
 Louisiana 70503
 USA
 Telephone: (337) 267 7888
 Facsimile: (337) 267 7476

www.wireline-international.com

Document Number:	TM11183600-0013	Revision:	0	Date:	12/01/11
Created by:	R Greenfield	Checked by:	B. Taylor	Approved by:	M Innes

Table Of Contents

1 General Information	5
1.1 Introduction	5
1.2 Guide ROLLER BOGIE™ Tools	5
2 Safety Manual	6
2.1 General Safety	6
2.2 Residual Hazards – transportation and storage	7
2.2.1 Residual Hazard – Heavy equipment	7
2.2.2 Residual Hazard – Inadequate restraint during storage	7
2.2.3 Residual Hazard – Inadequate preparation for storage	7
2.2.4 Residual Hazard – Inappropriate storage conditions	7
2.2.5 Residual Hazard – Inadequate preparation for transportation	7
2.2.6 Residual Hazard – potentially hazardous substances	7
2.2.7 Residual Hazard – Inadequate Personal Protective Equipment (PPE)	7
2.2.8 Residual Hazard – Sharp Edges and Pinch Points	7
2.3 Residual Hazards – Field Use	8
2.3.1 Residual Hazard – Heavy equipment	8
2.3.2 Residual Hazard – Inadequate restraint during field use	8
2.3.3 Residual Hazard – Inadequate preparation for use	8
2.3.4 Residual Hazard – Incorrect tool selection or placement	8
2.3.5 Residual Hazard – potentially hazardous substances	8
2.3.6 Residual Hazard – Inadequate Personal Protective Equipment (PPE)	8
2.3.7 Residual Hazard – Sharp Edges and Pinch Points	8
2.3.8 Residual Hazard – Use of damaged ROLLER BOGIE™ tool	8
2.3.9 Residual Hazard – Unauthorised Modification of the ROLLER BOGIE™ tool	9
2.3.10 Residual Hazard – Inadequate toolstring make-up	9
2.4 Residual Hazards – Maintenance	10
2.4.1 Residual Hazard – Heavy equipment	10
2.4.2 Residual Hazard – Inadequate restraint during maintenance	10
2.4.3 Residual Hazard – Use of non-genuine spares / consumables	10
2.4.4 Residual Hazard – Incorrect disassembly / reassembly	10
2.4.5 Residual Hazard – Potentially hazardous substances	10
2.4.6 Residual Hazard – Inadequate Personal Protective Equipment (PPE)	10
2.4.7 Residual Hazard – Sharp Edges and Pinch Points	10
2.4.8 Residual Hazard – Unauthorised Modification of the ROLLER BOGIE™ tool	10
3 Operation Manual	11
3.1 Selection & Operation of Slickline ROLLER BOGIE™ Tools	11
3.1.1 Selection of Slickline ROLLER BOGIE™ tools	11
3.1.2 Operating Procedure for Slickline ROLLER BOGIE™ tools	12
4 Maintenance Manual	13
4.1 General Maintenance Guidelines	13
4.2 Routine Maintenance Service	14
4.2.1 Routine Maintenance Service Frequency	14
4.2.2 Routine Maintenance Service Procedure (for all ROLLER BOGIE™ Tool Types)	14
4.2.3 Validation Following a Routine Maintenance Service	14
4.3 Major Maintenance Service	15

Document Number:	TM1182600-0013	Revision:	0	Date:	12-01-11
Created by:	R Greenfield	Checked by:	B. Taylor	Approved by:	H Innes

4.3.1 Major Maintenance Service Frequency	15
4.3.2 Major Maintenance Service Procedure	15
4.3.3 Validation Following a Major Maintenance Service	15
4.4 Approved Grease Types	16
4.4.1 Recommended grease for grease nipples & grease points	16
4.4.2 Recommended grease for other areas of lubrication during assembly	16
5 Disassembly & Assembly Instructions	17
Disassembly & Reassembly of a Guide ROLLER BOGIE™ Tool	17
5.1.1 Tools Required	17
5.1.2 Disassembly of a Guide ROLLER BOGIE™ Tool	17
5.1.3 Reassembly of a Guide ROLLER BOGIE™ Tool	19
6 Storage & Transportation	20
The following section of the manual describes the storage and transportation instructions for all ROLLER BOGIE™ tools.	20
6.1 Storage of ROLLER BOGIE™ tools	20
6.1.1 Prior to placing a ROLLER BOGIE™ tool into storage	20
6.1.2 Storage of ROLLER BOGIE™ tools	20
6.1.3 After removal of ROLLER BOGIE™ tool from storage	20
6.2 Transportation of ROLLER BOGIE™ tools	20
6.2.1 Prior to transporting a ROLLER BOGIE™ tool	20
6.2.2 During Transportation of ROLLER BOGIE™ tools	20
6.2.3 Procedure following transportation of ROLLER BOGIE™ tools	20
7 Appendices	21

Document Number:	TM11183600-0013	Revision:	0	Date:	12/01/11
Created by:	R Greenfield	Checked by:	B. Taylor	Approved by:	M Innes

Symbols

The following symbols are used throughout the manual to highlight particular levels of hazard associated with an operation.



A danger symbol highlights a hazard with potential risk of life-threatening injury or death of personnel.



A warning symbol highlights a hazard with potential risk of physical harm to personnel.

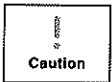

A caution symbol highlights a hazard with potential risk of damage to or loss of equipment, software, data or environment.



An information symbol highlights information that requires special attention.



A hint symbol highlights a tip or hint which will help improve a procedural step.

Document Number:	TM11 103600-0013	Revision:	0	Date:	12/01/11
Created by:	R Greenfield	Checked by:	B. Taylor	Approved by:	M Innes

1 General Information

1.1 Introduction

Wireline Engineering has developed a unique advanced roller technology and has engineered this into a series of innovative and functionally diverse conveyance products that allow intervention tool-strings to be run with virtually no frictional drag.

Installed strategically at critical points in the tool-string, Advanced Roller Systems lift and eliminate friction between the toolstring and the tubing surface.

Advanced Roller Systems from Wireline Engineering / Wireline International have become established in the international oil & gas community as the preferred means of transferring wireline or coiled tubing tool-strings to the required depth in deviated and tortuous well-bores.

With an extensive track record spanning six continents, successful operations have been performed at inclinations up to 86° and at depths below 24500ft (7470m).

The designs have also been developed to enable through-connection of hydraulic, electrical or ballistic control signals, allowing complete flexibility for integration and optimum positioning of the Advanced Roller Systems in the toolstring.

1.2 Guide ROLLER BOGIE™ Tools

Guide ROLLER BOGIE™ tools are designed to support and guide the bottom end of the toolstring.

The nose cone assists smooth passage of the toolstring past wellbore obstructions.

The body of the Guide ROLLER BOGIE™ tool is biased to ensure rotation without fail so that the rollers automatically fall on the low side of the well bore at all times.

The design features a swivel at the top of the Guide ROLLER BOGIE™ tool. This allows the toolstring to swivel, minimising wireline torque and reducing wear and tear on both the wire and the toolstring components.

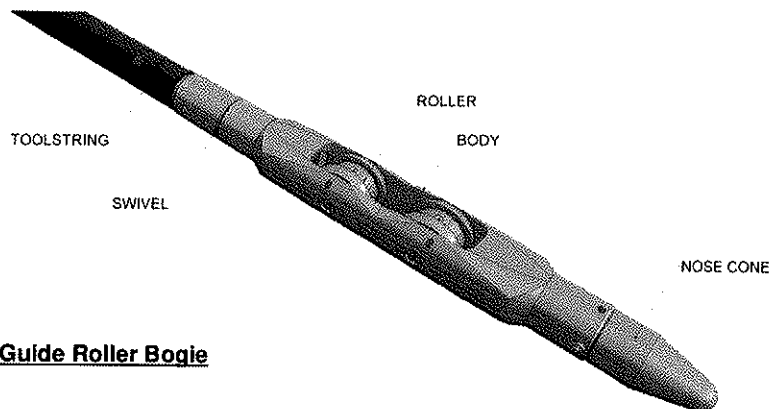

Figure 1: Guide Roller Bogie

Document Number:	TM11183600-0013	Revision:	0	Date:	12/01/11
Created by:	R Greenfield	Checked by:	B. Taylor	Approved by:	M Innes

2 Safety Manual

2.1 General Safety

SAFETY IS EVERYONE'S RESPONSIBILITY

This section of the manual highlights the residual hazards (associated with the ROLLER BOGIE™ tools) that have been identified at the design stage.

Planning (e.g. risk assessment) must be undertaken prior to any operation involving a ROLLER BOGIE™ tool in order to minimise (as far as is reasonably practical) the risks associated with these residual hazards.

This manual is not a substitute for local or national legal requirements in the region where the ROLLER BOGIE™ tool is to be used, or additional procedural requirements of the end user. These must be dealt with locally during the job planning stage.

PLAN – THINK HSE IN ADVANCE

Document Number:	TM111B3600-0013	Revision:	0	Date:	12/01/11
Created by:	R Greenfield	Checked by:	B. Taylor	Approved by:	M Innes

2.2 Residual Hazards – transportation and storage

2.2.1 Residual Hazard – Heavy equipment



ROLLER BOGIE™ tools can be very heavy. The weight of the ROLLER BOGIE™ tool is shown on the assembly drawing (see section 7). Do not manually handle the ROLLER BOGIE™ tool unless it is unavoidable. Only manually handle the ROLLER BOGIE™ tool if you have been trained in safe manual handling practices. If the ROLLER BOGIE™ tool is too heavy for safe manual handling, use a mechanical lifting device.

Potential Loss: Personal injury

2.2.2 Residual Hazard – Inadequate restraint during storage



Always store the ROLLER BOGIE™ tool either in a suitable container, or suitably restrained. Failure to do so could result in the ROLLER BOGIE™ tool rolling from its storage position and causing damage or personal injury.

Potential Loss: Personal injury / Equipment damage / Equipment Loss

2.2.3 Residual Hazard – Inadequate preparation for storage



Regardless of the expected duration of storage, always carry out appropriate maintenance (see section 4.2.2) before putting the ROLLER BOGIE™ tool into storage. Failure to do so could result in corrosion of parts and subsequent reduced performance of the ROLLER BOGIE™ tool.

Potential Loss: Equipment damage / Poor performance

2.2.4 Residual Hazard – Inappropriate storage conditions



Regardless of the expected duration of storage, always store the ROLLER BOGIE™ tool in a suitable environment indoors and protected from extremes of temperature and humidity. Failure to do so could result in corrosion of parts and subsequent reduced performance of the ROLLER BOGIE™ tool.

Potential Loss: Equipment damage / Poor performance

2.2.5 Residual Hazard – Inadequate preparation for transportation



Bearing in mind the expected duration and mode of transport, always transport the ROLLER BOGIE™ tool either in a suitable container or suitably restrained / protected. Failure to do so could result in contamination / corrosion of or vibration damage to parts and subsequent reduced performance of the ROLLER BOGIE™ tool.

If the tool has been in field use, ensure that the tool has been examined and serviced in accordance with section 4.2.2 before transportation.

Potential Loss: Equipment damage / Poor performance / Regulation breach

2.2.6 Residual Hazard – potentially hazardous substances



ROLLER BOGIE™ tools require the use of potentially hazardous substances. Material Safety Data Sheets are included in section 8. These substances must be handled, stored and transported in accordance with the appropriate countries' regulations.

Potential Loss: Personal injury / Environmental Damage

2.2.7 Residual Hazard – Inadequate Personal Protective Equipment (PPE)



Appropriate PPE must be worn during all ROLLER BOGIE™ operations. The level of PPE required must be determined locally during job planning.

Potential Loss: Personal injury

2.2.8 Residual Hazard – Sharp Edges and Pinch Points



In addition to the use of appropriate PPE, personnel must familiarise themselves with the potential pinch points and potentially sharp edges on the ROLLER BOGIE™ tool.

Potential Loss: Personal injury

Document Number:	TM11163600-0013	Revision:	0	Date:	12/01/11
Created by:	R Greenfield	Checked by:	B. Taylor	Approved by:	M Innes

2.3 Residual Hazards – Field Use

2.3.1 Residual Hazard – Heavy equipment



ROLLER BOGIE™ tools can be very heavy. The weight of the ROLLER BOGIE™ tool is shown on the assembly drawing (see section 7). Do not manually handle the ROLLER BOGIE™ tool unless it is unavoidable. Only manually handle the ROLLER BOGIE™ tool if you have been trained in safe manual handling practices. If the ROLLER BOGIE™ tool is too heavy for safe manual handling, use a mechanical lifting device.

Potential Loss: Personal injury

2.3.2 Residual Hazard – Inadequate restraint during field use



Always ensure that the ROLLER BOGIE™ tool is effectively restrained and is not left unattended on its wheels on an inappropriate surface. Failure to do so could result in the ROLLER BOGIE™ tool rolling uncontrolled from the position in which it was left and causing damage or personal injury. This is a particular hazard on floating vessels.

Potential Loss: Serious personal injury / Equipment damage / Equipment loss

2.3.3 Residual Hazard – Inadequate preparation for use



Regular maintenance of the ROLLER BOGIE™ tool is critical to its continued safe / reliable operation. Before releasing a ROLLER BOGIE™ tool for field use, ensure that it has been maintained correctly (see section 4) and is in a suitable condition for use. Failure to do so could result in reduced performance or failure of the ROLLER BOGIE™ tool.

Potential Loss: Equipment damage / Poor performance / Premature wear or tool failure

2.3.4 Residual Hazard – Incorrect tool selection or placement



Ensure that the most suitable ROLLER BOGIE™ tool is selected for the job being planned. In case of doubt, contact Wireline Engineering for technical help.

Potential Loss: Equipment damage / Poor performance

2.3.5 Residual Hazard – potentially hazardous substances



ROLLER BOGIE™ tools require the use of potentially hazardous substances. Material Safety Data Sheets are included in section 8. These substances must be handled, stored and transported in accordance with the appropriate country's regulations.

Potential Loss: Personal injury / Environmental Damage

2.3.6 Residual Hazard – Inadequate Personal Protective Equipment (PPE)



Appropriate PPE must be worn during all ROLLER BOGIE™ operations. The level of PPE required must be determined locally during job planning.

Potential Loss: Personal injury

2.3.7 Residual Hazard – Sharp Edges and Pinch Points



In addition to the use of appropriate PPE, personnel must familiarise themselves with the potential pinch points and potentially sharp edges on the ROLLER BOGIE™ tool.

Potential Loss: Personal injury

2.3.8 Residual Hazard – Use of damaged ROLLER BOGIE™ tool



If the ROLLER BOGIE™ tool has been exposed to an exceptional event (e.g. exposure to aggressive well fluids), or overload (e.g. during a fishing operation) or other damage, it is essential that the ROLLER BOGIE™ tool is examined to determine whether the exposure has been detrimental. Where damage is found, this must be rectified before further use of the ROLLER BOGIE™ tool.

Potential Loss: Personal injury / Poor performance / Premature wear or tool failure

Document Number:	TM11183600-0013	Revision:	6	Date:	12/01/11
Created by:	R Greenfield	Checked by:	B. Taylor	Approved by:	if Innes

2.3.9 Residual Hazard – Unauthorised Modification of the ROLLER BOGIE™ tool



The ROLLER BOGIE™ tool must not be modified in any way without prior approval from Wireline Engineering Department. Any unauthorised modification discovered must be rectified before proceeding with use.

Potential Loss: Personal injury / Poor performance / Premature wear or tool failure

2.3.10 Residual Hazard – Inadequate toolstring make-up



Connection of the ROLLER BOGIE™ tool to the toolstring (torque application method and torque value) must be made in accordance with the requirements of the party responsible for the toolstring e.g. the service company. Failure to do so could result in the ROLLER BOGIE™ tool becoming detached from the toolstring.

Potential Loss: Serious personal injury / Equipment damage / Equipment Loss

Document Number:	TM11163600-0013	Revision:	0	Date:	12/01/11
Created by:	B Greenfield	Checked by:	B. Taylor	Approved by:	R Innes

2.4 Residual Hazards – Maintenance

2.4.1 Residual Hazard – Heavy equipment



ROLLER BOGIE™ tools can be very heavy. The weight of the ROLLER BOGIE™ tool is shown on the assembly drawing (see section 7). Do not manually handle the ROLLER BOGIE™ tool unless it is unavoidable. Only manually handle the ROLLER BOGIE™ tool if you have been trained in safe manual handling practices. If the ROLLER BOGIE™ tool is too heavy for safe manual handling, use a mechanical lifting device.

Potential Loss: Personal injury

2.4.2 Residual Hazard – Inadequate restraint during maintenance



Always ensure that the ROLLER BOGIE™ tool is effectively restrained and is not left unattended on its wheels on an inappropriate surface. Failure to do so could result in the ROLLER BOGIE™ tool rolling uncontrolled from the position in which it was left and causing damage or personal injury. This is a particular hazard on floating vessels.

Potential Loss: Serious personal injury / Equipment damage / Equipment loss

2.4.3 Residual Hazard – Use of non-genuine spares / consumables



Only use genuine ROLLER BOGIE™ spare parts purchased directly from Wireline Engineering / Wireline International. Failure to do so could result in reduced performance or failure of the ROLLER BOGIE™ tool.

Potential Loss: Equipment damage / Poor performance / Premature wear or tool failure

2.4.4 Residual Hazard – Incorrect disassembly / reassembly



Always follow the disassembly / reassembly instructions carefully (see section 5). Always validate reassembly by testing the reassembled ROLLER BOGIE™ tool (see section 4)

Potential Loss: Equipment damage / Poor performance

2.4.5 Residual Hazard – Potentially hazardous substances



ROLLER BOGIE™ tools require the use of potentially hazardous substances. Material Safety Data Sheets are included in section 8. These substances must be handled, stored and transported in accordance with the appropriate country's regulations.

Potential Loss: Personal injury / Environmental Damage

2.4.6 Residual Hazard – Inadequate Personal Protective Equipment (PPE)



Appropriate PPE must be worn during all ROLLER BOGIE™ operations. The level of PPE required must be determined locally during job planning.

Potential Loss: Personal injury

2.4.7 Residual Hazard – Sharp Edges and Pinch Points



In addition to the use of appropriate PPE, personnel must familiarise themselves with the potential pinch points and potentially sharp edges on the ROLLER BOGIE™ tool.

Potential Loss: Personal injury

2.4.8 Residual Hazard – Unauthorised Modification of the ROLLER BOGIE™ tool



The ROLLER BOGIE™ tool must not be modified in any way without prior approval from Wireline Engineering Engineering Department. Unauthorised modifications discovered during maintenance must be rectified before releasing the ROLLER BOGIE™ tool for field service.

Potential Loss: Personal injury / Poor performance / Premature wear or tool failure

Document Number:	TM11183680-0013	Revision:	0	Date:	12/01/11
Created by:	R Greenfield	Checked by:	B. Taylor	Approved by:	M Innes

3 Operation Manual

3.1 Selection & Operation of Slickline ROLLER BOGIE™ Tools

The following section of the manual describes the selection and operating instructions for the use of slickline and monoconductor ROLLER BOGIE™ tools.

3.1.1 Selection of Slickline ROLLER BOGIE™ tools

At the job planning stage, it is essential that the most appropriate size and combination of ROLLER BOGIE™ tools for the job is selected.

Guidance on how to select the most appropriate size of ROLLER BOGIE™ tool is shown in Appendices (section 8).

The ROLLER BOGIE™ configuration in the toolstring should be designed to lift all parts of the toolstring clear of the tubing wall and to optimise the support of the toolstring.

Sections of the toolstring between ROLLER BOGIE™ tools should be as rigid as possible in order to avoid the toolstring grounding on the tubing wall, or other obstruction.

Typical toolstring configurations will use 3 or 4 ROLLER BOGIE™ tools. In special circumstances, as few as 2 ROLLER BOGIE™ tools may be used. Occasionally up to 12 ROLLER BOGIE™ tools have been used in past applications.

If knuckles are used in the toolstring then a ROLLER BOGIE™ tool must be positioned immediately above and below the knuckle.

Document Number:	TM111B3600-0013	Revision:	0	Date:	12/01/11
Created by:	R Greenfield	Checked by:	B. Taylor	Approved by:	M Innes

3.1.2 Operating Procedure for Slickline ROLLER BOGIE™ tools



Before proceeding with any ROLLER BOGIE™ tool operations ensure that provision has been made to minimise the risks associated with the residual hazards detailed in section 2.2



1. Thorough Visual Examination – Unpack the guide ROLLER BOGIE™ tool and carry out a thorough visual examination as described in section 4.2.2. This examination should determine whether the ROLLER BOGIE™ tool has suffered any damage or other ill effect during transportation to the wellsite.

2. Routine Maintenance Service – Carry out a routine maintenance service of the guide ROLLER BOGIE™ tool, as described in section 4.2.2.

3. Attach to Toolstring – Remove the thread protector and attach the guide ROLLER BOGIE™ tool to the bottom end of the toolstring. This connection (torque application method and torque value) must be made in accordance with the requirements of the party responsible for the toolstring e.g. the service company. Take care not to damage the threaded connection during this step.

4. Detach from the Toolstring – when the toolstring has been returned to surface, detach the guide ROLLER BOGIE™ tool from the toolstring. Take care not to damage the threaded connection during this step. Reattach the thread protector to the threaded connection.

5. Thorough Visual Examination – Clean the guide ROLLER BOGIE™ tool thoroughly and carry out a thorough visual examination as described in section 4.2.2. This examination should determine whether the guide ROLLER BOGIE™ tool has suffered any damage or other ill effect during the deployment.

6. Major Maintenance Service – Carry out a major maintenance service of the guide ROLLER BOGIE™ tool, as described in section 4.3.2. The extent of the major maintenance service may be customised by the competent person, taking into account the well conditions and fluids to which the guide ROLLER BOGIE™ tool has been exposed. Consumables may also be reused as deemed acceptable by the competent person following a visual examination and after taking into account well conditions and fluids to which the guide ROLLER BOGIE™ tool has been exposed.

7. Re-run – Repeat steps 3 thru 7 if the guide ROLLER BOGIE™ tool is to be run in hole again.

8. Prepare for Transportation – If the guide ROLLER BOGIE™ tool is not to be run in hole again, it should be prepared for transportation as described in section 6.2.1.

NOTE: The guide ROLLER BOGIE™ tool shown in the image is for illustration purposes only and may not accurately depict the tools described in this manual.

Document Number:	TM11183600-0013	Revision:	0	Date:	12/01/11
Created by:	R Greenfield	Checked by:	B. Taylor	Approved by:	M Innes

4 Maintenance Manual

4.1 General Maintenance Guidelines



Before proceeding with any ROLLER BOGIE™ tool maintenance ensure that provision has been made to minimise the risks associated with the residual hazards detailed in section 2.3

Regular maintenance is critical to the continued safe and reliable operation of ROLLER BOGIE™ tools. It is recommended that systems are put in place to control and record the correct periodic maintenance of ROLLER BOGIE™ products.



Application of grease is a critical part of ROLLER BOGIE™ maintenance. It is required both for lubrication, and for the exclusion of wellbore contaminants from the ROLLER BOGIE™ tool.

Ensure that suitable grease is used (see section 4.4 for Wireline Engineering recommended greases).

Document Number:	TM11103600-0013	Revision:	0	Date:	12/01/11
Created by:	R Greenfield	Checked by:	B. Taylor	Approved by:	M Innes

4.2 Routine Maintenance Service

4.2.1 Routine Maintenance Service Frequency

A routine service should be carried out at the following times:

- Prior to placing the ROLLER BOGIE™ tool into storage.
- Prior to packing the ROLLER BOGIE™ tool for transportation.
- Prior to connecting the ROLLER BOGIE™ tool to the toolstring for running in hole.
- At any other time as deemed necessary by the owner / user e.g. when the current condition of a ROLLER BOGIE™ tool is unknown.



4.2.2 Routine Maintenance Service Procedure (for all ROLLER BOGIE™ Tool Types)

1. Carry out a thorough visual examination of the ROLLER BOGIE™ tool. This examination should determine whether the ROLLER BOGIE™ tool is fit for purpose. Partial or complete disassembly may be required to the extent deemed necessary to complete the thorough examination. The examination must include:
 - An assessment of the condition of the upper end connection fitted to the ROLLER BOGIE™ tool.
 - An assessment of the level of wear of the ROLLER BOGIE™ components.
 - An assessment of the level of corrosion of the ROLLER BOGIE™ components.
1. Repair or replace any components found to be inadequate during the thorough visual examination (section 5 details the procedures for disassembly and reassembly required to replace parts). Only use genuine spare parts procured through Wireline Engineering Ltd or Wireline International LLC. Redress Kit 11180000-5003 contain all consumable items required to overhaul this ROLLER BOGIE™ tool.
2. Use the grease gun to inject grease (photo). There is one port per roller and one or two ports per body. Approximately 3-5 strokes are likely to be required per port; excess will exit from the opposite side. (see section 4.4 for suitable greases)

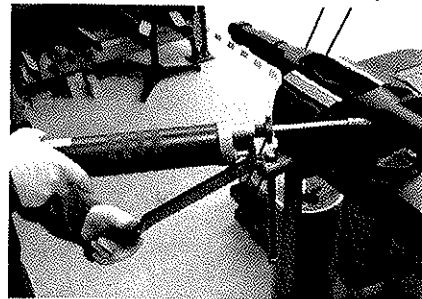

4.2.3 Validation Following a Routine Maintenance Service



Rollers and swivels may lock up initially after greasing and need to be manipulated until they rotate freely.

After completion of the routine maintenance service, the ROLLER BOGIE™ tool must be tested to ensure that it functions correctly:

1. Rotate the upper swivel to ensure that they rotate freely.
2. Lay the assembly on a flat workbench and roll back and forth to ensure that all rollers rotate freely.

Document Number:	TM11183660-0013	Revision:	0	Date:	12/01/11
Created by:	R Greenfield	Checked by:	B. Taylor	Approved by:	M James

4.3 Major Maintenance Service

4.3.1 Major Maintenance Service Frequency

A major maintenance service should be carried out at the following times:

- Following retrieval of a ROLLER BOGIE™ tool from a run in hole.
- Following an extended period of storage of the ROLLER BOGIE™ tool.
- When inferior performance or condition of the ROLLER BOGIE™ tool has been observed.
- Following an exceptional event (e.g. exposure to aggressive well fluids, or following overload – during fishing for example)
- At any other time as deemed necessary by the owner / user e.g. when the current condition of a ROLLER BOGIE™ tool is unknown and there is doubt about its performance.

4.3.2 Major Maintenance Service Procedure

2. Follow the procedure in section 5 to disassemble the ROLLER BOGIE™ tool.
3. Carry out a thorough visual examination of all of the ROLLER BOGIE™ tool components. The examination must include:
 - An assessment of the condition of the upper and lower end connections fitted to the ROLLER BOGIE™ tool.
 - An assessment of the condition of all of the internal threaded parts in the ROLLER BOGIE™ tool.
 - An assessment of the level of wear of the ROLLER BOGIE™ components.
 - An assessment of the level of corrosion of the ROLLER BOGIE™ components.
4. Repair or replace any components found to be inadequate during the thorough visual examination. Only use genuine spare parts procured through Wireline Engineering Ltd or Wireline International LLC. Redress Kit 11180000-5003 contains all consumable items required to overhaul this ROLLER BOGIE™ tool.
5. Follow the procedure in section 5 to reassemble the ROLLER BOGIE™ tool.
6. Use the grease gun to inject grease (photo). There is one port per roller and one or two ports per body. Approximately 3-5 strokes are likely to be required per port; excess will exit from the opposite side. (see section 4.4 for suitable greases)

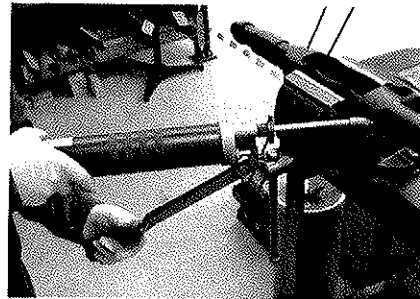

4.3.3 Validation Following a Major Maintenance Service



Rollers and swivels may lock up initially after greasing and need to be manipulated until they rotate freely.

After completion of the major maintenance service, the ROLLER BOGIE™ tool must be tested to ensure that it functions correctly:

1. Rotate the upper swivel to ensure that they rotate freely.
2. Lay the assembly on a flat workbench and roll back and forth to ensure that all rollers rotate freely.

Document Number:	TM11183600-0013	Revision:	0	Date:	12/01/11
Created by:	R Greenfield	Checked by:	B. Taylor	Approved by:	M Innes

4.4 Approved Grease Types



Application of grease is a critical part of ROLLER BOGIE™ maintenance. It is required both for lubrication, and for the exclusion of wellbore contaminants from the ROLLER BOGIE™ tool.

Ensure that suitable grease is used (see below).

4.4.1 Recommended grease for grease nipples & grease points

Wireline Engineering recommends the following high temperature grease for all ROLLER BOGIE™ tool grease nipples and grease holes, e.g. all rollers and swivels.

- **'Duron Foodmaster Clear 2'**

If an alternative grease must be used, ensure that it has equivalent or superior viscosity and high temperature performance characteristics to this recommended grease. 'Duron Foodmaster Clear 2' must be used for all ROLLER BOGIE™ tool operations within USA waters.

Other regions may also have regulatory requirements which influence the choice of grease. Ensure that the grease used satisfies local regulatory and company requirements.

4.4.2 Recommended grease for other areas of lubrication during assembly

When applying grease to areas not detailed in section 4.4.1, (e.g. grubs screws, O-ring & thread lubrication) Wireline Engineering recommends the following grease during assembly:

- **'Duron Multip 2'**

Document Number:	TM11183600-0013	Revision:	0	Date:	12/01/11
Created by:	R Greenfield	Checked by:	B. Taylor	Approved by:	M Innes

5 Disassembly & Assembly Instructions

Disassembly & Reassembly of a Guide ROLLER BOGIE™ Tool

The following section of the manual describes the disassembly and reassembly instructions for a guide ROLLER BOGIE™ tool.

5.1.1 Tools Required

- Hammer.
- 5/32in & 3/16in Diameter Short and Long Punches.
- 2 ROLLER BOGIE™ Keys.
- O-Ring / Wiper Extraction Tool.
- Bench Vice with non-marking jaws.
- 1/8" Allen Key.
- Grease Gun.

5.1.2 Disassembly of a Guide ROLLER BOGIE™ Tool



Throughout the following procedures, reference must be made to the relevant assembly drawing (see section 7)

5.1.2.1 Prior to Disassembly

Before starting disassembly, carry out a thorough visual examination of the ROLLER BOGIE™ tool. This examination should assess the general condition of the ROLLER BOGIE™ tool. The examination must include:

1. An assessment of the condition of the upper and lower end connections fitted to the ROLLER BOGIE™ tool.
2. A general assessment of the level of external wear of the ROLLER BOGIE™ components.
3. An assessment of the level of external corrosion of the ROLLER BOGIE™ components.
4. An assessment of whether there are any ROLLER BOGIE™ parts missing from the assembly.
5. An assessment of the functionality of the ROLLER BOGIE™ tool. Check the swivels at the upper and lower ends to assess whether they rotate freely and smoothly. Check the rollers to assess whether they rotate freely and smoothly. Check that the ROLLER BOGIE™ tool self rights and rolls onto its wheels from all orientations.

Document Number:	TM11183600-0013	Revision:	0	Date:	12/01/11
Created by:	R Greenfield	Checked by:	B. Taylor	Approved by:	M Innes

5.1.2.2 Guide ROLLER BOGIE™ Tool Disassembly Procedure



Unless it is seriously damaged or corroded, the nose cone need not be removed from the main body.



The linear bearing bushes are factory fitted and should not be extracted from the main body. If they show surface damage, carefully dress the damage. If the damage is more severe the ROLLER BOGIE™ tool should be returned to Wireline Engineering / Wireline International for refurbishment.

1. Grip the main body (1) in the vice.
2. Remove the roll pins (10) securing the roller pins (5) to the main body (1).
3. Unscrew each roller pin (5.1 & 5.2) using the Roller Bogie Keys.
4. Remove the rollers (6) from the main body (1).
5. Remove the roll pin (10) securing the top sub (4) to the rotating end pin (3).
6. Locate the slot in the rotating end pin (3) with the disassembly tool and unscrew the top sub (4).
7. Remove the rotating end pin (3) from the main body (1).
8. Make a unique mark to show the relationship between the rotating end pin (3) and the top sub (4).
The roll pin holes are drilled through the top sub and rotating end pin at assembly. They are therefore a "matching pair" and are not interchangeable.
9. Remove the wipers (11) from the rollers (6).
10. Thoroughly clean and dry all components.

5.1.2.3 Following Disassembly

After disassembly, carry out a thorough visual examination of the ROLLER BOGIE™ components. This examination should assess in detail the condition of the ROLLER BOGIE™ components. The examination must include:

1. An assessment of the condition of the upper and lower end connections fitted to the ROLLER BOGIE™ tool.
2. A general assessment of the level of internal wear of the ROLLER BOGIE™ components.
3. An assessment of the level of internal corrosion of the ROLLER BOGIE™ components.

Repair or replace components as deemed necessary. All O-rings and roll pins should be replaced after every disassembly.

Document Number:	TM11183600-0013	Revision:	0	Date:	12/01/11
Created by:	R Greenfield	Checked by:	B. Taylor	Approved by:	M Innes

5.1.3 Reassembly of a Guide ROLLER BOGIE™ Tool



Throughout the following procedures, reference must be made to the relevant assembly drawing (see section 7)

5.1.3.1 Guide ROLLER BOGIE™ Tool Reassembly Procedure



Use an appropriate high temperature grease sparingly on all internal connections and O-Rings (see section 4.4 for Wireline Engineering recommended greases).



Socket head set screws must be lightly greased before insertion, and tightened to a torque of 5.5 NM & 15 NM for 1/4" & 3/8" sizes respectively.

1. Insert the wipers (11) into rollers (6).
2. Insert the rotating end pin (3) into the main body (1).
3. Locate the slot on the rotating end pin (3) with the ROLLER BOGIE™ key and screw on the top sub (4).
4. Insert the roll pins (10) through the top sub (4) and rotating end pin (3).
5. Insert a roller (6) into the main body (1).
6. Pass a roller pin (5.1 & 5.2) through the main body (1) and roller (6) and tighten with Roller Bogie Keys.
7. Insert a roll pin (10) through the main body (1) to retain the roller pin (5).
8. Repeat steps 5 thru 8 for the second roller.
9. Apply grease through the grease nipples (8) in the roller and main body using a grease gun.

5.1.3.2 Validation



Rollers and swivels may lock up initially after greasing and need to be manipulated until they rotate freely.

After completion of the reassembly, the ROLLER BOGIE™ tool must be tested to ensure that it functions correctly:

1. Rotate the upper swivel to ensure that they rotate freely.
2. Lay the assembly on a flat workbench and roll back and forth to ensure that all rollers rotate freely.

Document Number:	TW11183600-0013	Revision:	0	Date:	12/01/11
Created by:	R Greenfield	Checked by:	B. Taylor	Approved by:	M Innes

6 Storage & Transportation

The following section of the manual describes the storage and transportation instructions for all ROLLER BOGIE™ tools.



Before storing or transporting any ROLLER BOGIE™ tool, ensure that provision has been made to minimise the risks associated with the residual hazards detailed in section 2.2

6.1 Storage of ROLLER BOGIE™ tools

6.1.1 Prior to placing a ROLLER BOGIE™ tool into storage

Routine Maintenance Service – Carry out a routine maintenance service of the guide ROLLER BOGIE™ tool, as described in section 4.2.2

6.1.2 Storage of ROLLER BOGIE™ tools

6.1.2.1 Packing Requirements

It is recommended that where possible a ROLLER BOGIE™ tool is stored in a suitable and appropriately sized container. Do not put other tools or items in the same container. Storage in a container serves 2 functions: firstly it provides protection and minimises the risk of damage; secondly it restrains the ROLLER BOGIE™ tool to prevent it rolling from its storage position and causing loss, damage or injury.

The contents of the container should be clearly marked for future reference, as well as the date the tool was placed into storage.

6.1.2.2 Conditions of Storage

Before placing a ROLLER BOGIE™ tool into storage ensure that the storage location is clean, dry and unaffected by extremes of temperature or humidity.

6.1.3 After removal of ROLLER BOGIE™ tool from storage

Routine Maintenance Service – Carry out a routine maintenance service of the ROLLER BOGIE™ tool, as described in section 4.2.2

6.2 Transportation of ROLLER BOGIE™ tools

6.2.1 Prior to transporting a ROLLER BOGIE™ tool

Routine Maintenance Service – Carry out a routine maintenance service of the ROLLER BOGIE™ tool, as described in section 4.2.2

6.2.2 During Transportation of ROLLER BOGIE™ tools

6.2.2.1 Packing Requirements

It is recommended that where possible a ROLLER BOGIE™ tool is transported in a suitable and appropriately sized container. Do not put other tools or items in the same container. To minimise the risk of damage to the ROLLER BOGIE™ tool and container, ensure that the ROLLER BOGIE™ tool is suitably restrained.

6.2.2.2 Conditions of Transportation

Ensure that the ROLLER BOGIE™ tool is transported in a container that is clean, dry and unaffected by extremes of temperature or humidity.

Ensure that the stored ROLLER BOGIE™ tool and/or container are adequately restrained to minimise the risk of damage or injury.

6.2.3 Procedure following transportation of ROLLER BOGIE™ tools

- 1. Thorough Visual Examination** – Unpack the ROLLER BOGIE™ tool and carry out a thorough visual examination as described in section 4.2.2. This examination should determine whether the ROLLER BOGIE™ tool has suffered any damage or other ill effect during transportation.
- 2. Routine Maintenance Service** – Carry out a routine maintenance service of the ROLLER BOGIE™ tool, as described in section 4.2.2.

Document Number:	YM11182600-0013	Revision:	0	Date:	12/01/11
Created by:	R Greenfield	Checked by:	B. Taylor	Approved by:	M Innes

7 Appendices

Appendix I
Toolstring Clearance Data

Appendix II
Using the Toolstring Clearance Table to select a ROLLER BOGIE™ tool

Appendix III
Greasing Roller Tools Guide

Appendix IV
COSHH Sheets

Appendix V
Assembly Drawing(s)

Document Number:	TM11183600-0013	Revision:	0	Date:	12/01/11
Created by:	B Greenfield	Checked by:	B. Taylor	Approved by:	M Innes

CHOOSING THE CORRECT ROLLER BOGIE™ SIZE

The purpose of Roller Bogies is to eliminate or reduce friction by lifting and carrying the complete toolstring, enabling the wireline operation to be successful under challenging conditions. Use the table overleaf to determine the clearance (the "lift", space or gap) between the toolstring and the low side of the tubing or casing.

How much clearance is enough?

The ideal clearance or lift depends on the type of job to be performed. Clearance is a function of the effective Roller Bogie OD and toolstring dimensions, which in turn are guided and governed by physical well-bore conditions including restrictions, depth, angle, wire diameter, well-bore geometry, sand protection etc.

Slickline: In an older well, the wireline operator may choose to have greater clearance due to corrosion, well bore deterioration, sand deposits etc. In a new well with clean tubing the operator may be successful with an extremely small clearance.

Electric line: When perforating, for example, typically the guns need to be as close to the wall as possible for maximum performance, yet may need to allow clearance for swelling/ burring when pulling out of hole. The configuration for subsequent runs may have to take into account the need to roll over the detritus left from previously detonated guns. PL runs have other needs & requirements.

Using the table to choose Roller Bogie size.

1. Determine the Roller Bogie size that can be used in your application. For example, if there is a 2.595in restriction, the largest Roller Bogie that could be used is 2.4in
2. What size toolstring will be used?

Example 1: We will assume 1-7/8in stem.

On the left of the table find 1-7/8in. At the top of the table find 2.4in Roller Bogie. The number shown where 1-7/8in Toolstring intersects with 2.4in Roller Bogie (0.17in) is the space in inches between the toolstring (or a toolstring component) and the low side of the tubing. **Note:** In this example, 2.275in Roller Bogies would also be appropriate, giving a clearance of 0.14in. The "Correct" choice of Roller Bogie depends on what job the wireline operator is performing.

Example 2: Although the 1.80in Roller Bogie would be suitable for a restriction of 1.925in, using a 1-7/8in toolstring yields NO clearance – the Roller Bogie wheels would not be in contact with the tubing, so the toolstring would be sliding, not rolling. This means there would be NO friction reduction.

Example 3: For the same restriction of 1.925in, using the 1.8in Roller Bogie with a 1-1/4in toolstring yields a clearance of 0.27in – this combination is an excellent means to reduce friction.

Our objective is to advise on clearances and the suitability of various tool sizes and configurations – which Roller Bogies will assist and enable you to run what size tools, etc. Ultimately, it is the knowledge, skill and experience of the wireline operator that determines the final outcome of the job.

Document Number:	TM11183600-0013	Revision:	0	Date:	12/01/11
Created by:	R Greenfield	Checked by:	B. Taylor	Approved by:	M Innes

SLICKLINE ROLLER BOGIES: RELATIVE CLEARANCE or LIFT

NOTE: REFERENCE CASING/TUBING SIZES ARE SHOWN FOR CALCULATION PURPOSES ONLY. ROLLER BOGIE SIZES SHOULD BE CHOSEN TO SUIT OPERATIONAL NEEDS

Roller Bogie Dia →	1.600	1.800	1.900	2.125	2.275	2.400	2.500	2.600	2.770	3.000	3.350	3.600	3.700	3.850	4.100	4.500	4.900	5.500		
Ref. Tbg/Csg Size →	2.3/8	2.7/8	2.7/8	2.7/8	2.7/8	3.1/2	3.1/2	3.1/2	3.1/2	4.1/2	4.1/2	4.1/2	4.1/2	4.1/2	5	5.1/2	7	7		
Ref. Tbg/Csg Wt →	4.6	6.4	6.4	6.4	6.4	9.2	9.2	9.2	9.2	12.6	12.6	12.6	12.6	12.6	15	17	29	29		
Dimension "B" →	0.797	0.892	0.930	0.977	1.074	1.104	1.171	1.240	1.313	1.363	1.573	1.690	1.738	1.849	1.938	2.103	2.285	2.585		
Component or Toolstring OD	* Dimension "B" is the distance between the center line of the Roller Bogie and the low side of the well bore.																			
1	1.000	0.30	0.39	0.49	0.48	0.57	0.60	0.67	0.74	0.81	0.86	1.07	1.19	1.24	1.35	1.44	1.60	1.79	2.09	
1.1/16	1.063	0.27	0.36	0.40	0.45	0.54	0.57	0.64	0.71	0.78	0.83	1.04	1.16	1.21	1.32	1.41	1.57	1.75	2.05	
1.1/8	1.125	0.23	0.33	0.37	0.41	0.51	0.54	0.61	0.68	0.75	0.80	1.01	1.13	1.18	1.29	1.38	1.54	1.72	2.02	
1.3/16	1.188	0.20	0.30	0.34	0.38	0.48	0.51	0.58	0.65	0.72	0.77	0.98	1.10	1.14	1.26	1.34	1.51	1.69	1.99	
1.1/4	1.250	0.17	0.27	0.31	0.35	0.45	0.48	0.55	0.62	0.69	0.74	0.95	1.07	1.11	1.22	1.31	1.48	1.66	1.96	
1.5/16	1.313	0.14	0.24	0.27	0.32	0.42	0.45	0.51	0.58	0.66	0.71	0.92	1.03	1.08	1.19	1.28	1.45	1.63	1.93	
1.3/8	1.375	0.11	0.20	0.24	0.29	0.39	0.42	0.48	0.55	0.63	0.68	0.89	1.00	1.05	1.16	1.25	1.42	1.60	1.90	
1.7/16	1.438	0.08	0.17	0.21	0.26	0.36	0.39	0.45	0.52	0.59	0.64	0.85	0.97	1.02	1.13	1.22	1.38	1.57	1.87	
1.1/2	1.500	0.05	0.14	0.18	0.23	0.32	0.35	0.42	0.49	0.56	0.61	0.82	0.94	0.99	1.10	1.19	1.35	1.54	1.84	
1.9/16	1.563	0.02	0.11	0.15	0.20	0.29	0.32	0.39	0.46	0.53	0.58	0.79	0.91	0.96	1.07	1.16	1.32	1.50	1.80	
1.5/8	1.625	0.08	0.12	0.16	0.26	0.29	0.36	0.43	0.50	0.55	0.76	0.88	0.93	1.04	1.13	1.29	1.47	1.77		
1.11/16	1.688	0.05	0.09	0.13	0.23	0.26	0.33	0.40	0.47	0.52	0.73	0.85	0.89	1.01	1.09	1.26	1.44	1.74		
1.3/4	1.750	0.02	0.06	0.10	0.20	0.23	0.30	0.37	0.44	0.49	0.70	0.82	0.86	0.97	1.06	1.23	1.41	1.71		
1.13/16	1.813			0.02	0.07	0.17	0.20	0.26	0.33	0.41	0.46	0.67	0.78	0.83	0.94	1.03	1.20	1.38	1.68	
1.7/8	1.875				0.04	0.14	0.17	0.23	0.30	0.38	0.43	0.64	0.75	0.80	0.91	1.00	1.17	1.35	1.65	
1.15/16	1.938				0.01	0.11	0.14	0.20	0.27	0.34	0.39	0.60	0.72	0.77	0.88	0.97	1.13	1.32	1.62	
2	2.000					0.07	0.10	0.17	0.24	0.31	0.36	0.57	0.69	0.74	0.85	0.94	1.10	1.29	1.59	
2.1/8	2.125					0.01	0.04	0.11	0.18	0.25	0.30	0.51	0.63	0.68	0.79	0.88	1.04	1.22	1.52	
2.1/4	2.250							0.05	0.12	0.19	0.24	0.45	0.57	0.61	0.72	0.81	0.98	1.16	1.46	
2.3/8	2.375								0.05	0.13	0.18	0.39	0.50	0.55	0.66	0.75	0.92	1.10	1.40	
2.1/2	2.500									0.06	0.11	0.32	0.44	0.49	0.60	0.69	0.85	1.04	1.34	
2.5/8	2.625										0.05	0.26	0.38	0.43	0.54	0.63	0.79	0.97	1.27	
2.11/16	2.688										0.02	0.23	0.35	0.39	0.51	0.59	0.76	0.94	1.24	
2.3/4	2.750											0.20	0.32	0.36	0.47	0.56	0.73	0.91	1.21	
2.7/8	2.875											0.14	0.25	0.30	0.41	0.50	0.67	0.85	1.15	
3	3.000											0.07	0.19	0.24	0.35	0.44	0.60	0.79	1.09	
3.1/8	3.125											0.01	0.13	0.18	0.29	0.38	0.54	0.72	1.02	
3.1/4	3.250												0.06	0.11	0.22	0.31	0.48	0.66	0.96	
3.3/8	3.375												0.05	0.16	0.25	0.42	0.60	0.90		
3.1/2	3.500													0.10	0.19	0.35	0.54	0.84		
3.5/8	3.625													0.04	0.13	0.29	0.47	0.77		
3.3/4	3.750														0.06	0.23	0.41	0.71		
3.7/8	3.875															0.17	0.35	0.65		
4	4.000																0.10	0.29	0.59	
4.1/8	4.125																0.04	0.22	0.52	
4.1/4	4.250																	0.16	0.46	
4.3/8	4.375																		0.10	0.40
4.1/2	4.500																		0.04	0.34
4.5/8	4.625																			0.27
4.3/4	4.750																			0.21
5	5.000																			0.09

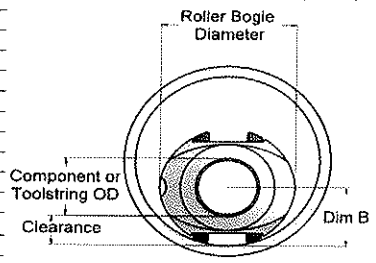

Document Number:	TM11103600-0613	Revision:	0	Date:	12/01/11
Created by:	R Greenfield	Checked by:	B. Taylor	Approved by:	M Innes

ELECTRIC LINE ROLLER BOGIES: RELATIVE CLEARANCE or LIFT

NOTE: REFERENCE CASING/TUBING SIZES ARE SHOWN FOR CALCULATION PURPOSES ONLY. ROLLER BOGIE SIZES SHOULD BE CHOSEN TO SUIT OPERATIONAL NEEDS

Roller Bogie Dia →		1.950	2.125	2.275	2.400	2.500	2.600	2.770	3.000	3.350	3.600	3.850	4.100	4.500	4.900	5.500
Ref. Tbg/Csg Size →		2.3/8	2.7/8	2.7/8	3.1/2	3.1/2	3.1/2	3.1/2	4.1/2	4.1/2	4.1/2	4.1/2	5	5.1/2	7	7
Ref. Tbg/Csg Wt →		4.600	6.400	6.400	9.200	9.200	9.200	9.200	12.6	12.6	12.6	12.6	15	17	29	29
Dimension "B" →		0.936	1.000	1.071	1.122	1.179	1.227	1.323	1.345	1.571	1.688	1.874	1.947	2.101	2.284	2.602
Component or Toolstring OD		* Dimension "B" is the distance between the center line of the Roller Bogie and the low side of the well bore.														
1	1.000	0.44	0.50	0.57	0.62	0.68	0.73	0.82	0.85	1.07	1.19	1.37	1.45	1.60	1.78	2.10
1.1/16	1.063	0.40	0.47	0.54	0.59	0.65	0.70	0.79	0.81	1.04	1.16	1.34	1.42	1.57	1.75	2.07
1.1/8	1.125	0.37	0.44	0.51	0.56	0.62	0.66	0.76	0.78	1.01	1.13	1.31	1.38	1.54	1.72	2.04
1.3/16	1.188	0.34	0.41	0.48	0.53	0.59	0.63	0.73	0.75	0.98	1.09	1.28	1.35	1.51	1.69	2.01
1.1/4	1.250	0.31	0.38	0.45	0.50	0.55	0.60	0.70	0.72	0.95	1.06	1.25	1.32	1.48	1.66	1.98
1.5/16	1.313	0.28	0.34	0.41	0.47	0.52	0.57	0.67	0.69	0.91	1.03	1.22	1.29	1.44	1.63	1.95
1.3/8	1.375	0.25	0.31	0.38	0.43	0.49	0.54	0.64	0.66	0.88	1.00	1.19	1.26	1.41	1.60	1.91
1.7/16	1.438	0.22	0.28	0.35	0.40	0.46	0.51	0.60	0.63	0.85	0.97	1.16	1.23	1.38	1.57	1.88
1.1/2	1.500	0.19	0.25	0.32	0.37	0.43	0.48	0.57	0.60	0.82	0.94	1.12	1.20	1.35	1.53	1.85
1.9/16	1.563	0.15	0.22	0.29	0.34	0.40	0.45	0.54	0.56	0.79	0.91	1.09	1.17	1.32	1.50	1.82
1.5/8	1.625	0.12	0.19	0.26	0.31	0.37	0.41	0.51	0.53	0.76	0.88	1.06	1.13	1.29	1.47	1.79
1.11/16	1.688	0.09	0.16	0.23	0.28	0.34	0.38	0.48	0.50	0.73	0.84	1.03	1.10	1.26	1.44	1.76
1.3/4	1.750	0.06	0.13	0.20	0.25	0.30	0.35	0.45	0.47	0.70	0.81	1.00	1.07	1.23	1.41	1.73
1.13/16	1.813	0.03	0.09	0.16	0.22	0.27	0.32	0.42	0.44	0.66	0.78	0.97	1.04	1.19	1.38	1.70
1.7/8	1.875		0.06	0.13	0.18	0.24	0.29	0.39	0.41	0.63	0.75	0.94	1.01	1.16	1.35	1.66
1.15/16	1.938		0.03	0.10	0.15	0.21	0.26	0.35	0.38	0.60	0.72	0.91	0.98	1.13	1.32	1.63
2	2.000			0.07	0.12	0.18	0.23	0.32	0.35	0.57	0.69	0.87	0.95	1.10	1.28	1.60
2.1/8	2.125				0.06	0.12	0.16	0.26	0.28	0.51	0.63	0.81	0.88	1.04	1.22	1.54
2.1/4	2.250					0.05	0.10	0.20	0.22	0.45	0.56	0.75	0.82	0.98	1.16	1.48
2.3/8	2.375						0.04	0.14	0.16	0.38	0.50	0.69	0.76	0.91	1.10	1.41
2.1/2	2.500							0.07	0.10	0.32	0.44	0.62	0.70	0.85	1.03	1.35
2.5/8	2.625							0.01	0.03	0.26	0.38	0.56	0.63	0.79	0.97	1.29
2.11/16	2.688									0.23	0.34	0.53	0.60	0.76	0.94	1.26
2.3/4	2.750									0.20	0.31	0.50	0.57	0.73	0.91	1.23
2.7/8	2.875									0.13	0.25	0.44	0.51	0.66	0.85	1.16
3	3.000								0.07	0.19	0.37	0.45	0.60	0.78	1.10	
3.1/8	3.125									0.13	0.31	0.38	0.54	0.72	1.04	
3.1/4	3.250									0.06	0.25	0.32	0.48	0.66	0.98	
3.3/8	3.375										0.19	0.26	0.41	0.60	0.91	
3.1/2	3.500										0.12	0.20	0.35	0.53	0.85	
3.5/8	3.625										0.06	0.13	0.29	0.47	0.79	
3.3/4	3.750											0.07	0.23	0.41	0.73	
3.7/8	3.875												0.01	0.16	0.35	0.66
4	4.000													0.10	0.28	0.60
4.1/8	4.125													0.04	0.22	0.54
4.1/4	4.250														0.16	0.48
4.3/8	4.375														0.10	0.41
4.1/2	4.500														0.03	0.35
4.5/8	4.625															0.29
4.3/4	4.750															0.23
5	5.000															0.10

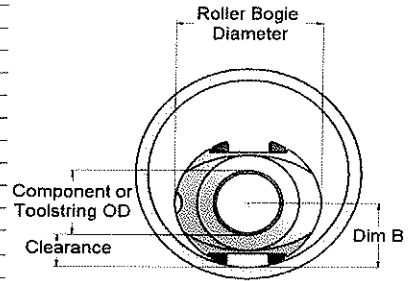

Document Number:	TM11183600-0013	Revision:	0	Date:	12/01/11
Created by:	R Greenfield	Checked by:	B. Taylor	Approved by:	M Innes

ROLLER BOGIES - FIELD MAINTENANCE

1. LOCATE GREASE PORTS ON WHEELS

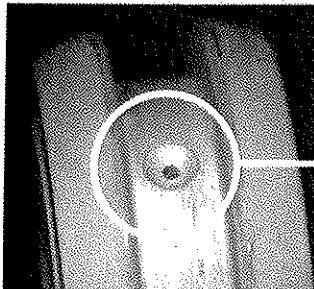

SLICKLINE

2 PORTS PER ROLLER

(GREASE IS INJECTED INTO ONE PORT PER ROLLER; ANY EXCESS GREASE EXITS FROM THE OPPOSITE SIDE).

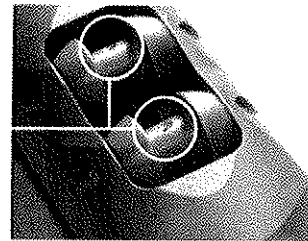

ELECTRIC LINE

2. LOCATE GREASE PORTS ON BODY

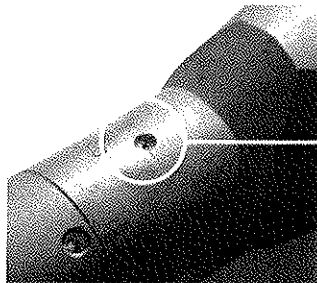

TYPE 1

BODY HAS 2 PORTS

GREASE PORTS ARE EITHER TYPE 1 OR 2 (BUT NOT BOTH).

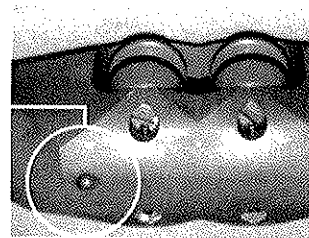

TYPE 2

3. INJECT GREASE – *PRIOR TO EVERY RUN*

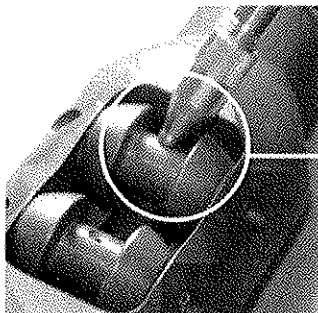

USE THE GREASE GUN AND SPECIAL PLAIN NIPPLE (PROVIDED) TO INJECT GREASE AT:

- ONE PORT PER ROLLER
 - 2 ROLLERS FOR SLICKLINE
 - 4 ROLLER FOR E-LINE
- TWO BODY PORTS

HOW MUCH GREASE?

APPROXIMATELY 3-5 STROKES PER PORT. EXCESS WILL EXTRUDE FROM OPPOSITE PORT (ROLLERS) AND AT SHOULDERS (BODY PORTS).

Document Number:	TM11183660-0013	Revision:	0	Date:	12/01/11
Created by:	R Greenfield	Checked by:	B. Taylor	Approved by:	M Innes

HEALTH & SAFETY DATA:
LUBRIPLATE 930-A (Information copied here, original documents available)

Section 1

PRODUCT NAME OR NUMBER
FORMULA

 LUBRIPLATE No. 930-A, No. 930AA,
 No. 930AAA, 930-2

Inorganic Thickener, Mineral Oil and Additives

GENERIC/CHEMICAL NAME:
USDA AUTHORIZATION

Petroleum Lubricating Grease

H-2

Manufacturer's Name

Emergency Telephone Number

Fiske Brothers Refining Co.

1-800-255-3924-CHEM-TEL(24 Hours)

Address
Telephone Number for Information

1500 Oakdale Ave., Toledo, Ohio 43605

419-691-2491 – Toledo

129 Lockwood Street, Newark, NJ 07105

Office

Section 2 – Hazardous Ingredients/Identify Information

Hazardous Components OSHA PEL ACGIH TLV Non Hazardous

Other Limits Recommended % (Optional)

Hazardous Material Identification System (HMIS) Health - 1, Flammability - 1, Reactivity - 0

Not a Controlled Product under (WHMIS) – Canada **Special Protection:** See Section 9

Section 3 – Health Hazard Data

Threshold Limit Value 5mg/m3 for oil mist in air. OSHA Regulation 29 CFR 910.1000

Effects of Overexposure: Prolonged or repeated skin contact may cause skin irritation. Product contacting the eyes may cause eye irritation. Human health risks vary from person to person. As a precaution, exposure to liquids, vapours, mists and fumes should be minimized. This product has a low order of acute oral toxicity, but minute amounts aspirated into the lungs during ingestion may cause mild to severe pulmonary injury.

Carcinogenicity: NTP? No

IARC Monographs? No

OSHA Regulated? No

Section 4 – Emergency and First Aid Procedures

EYE CONTACT: Flush with clear water for 15 minutes or until irritation subsides. If irritation persists, consult a physician.

SKIN CONTACT: Remove any contaminated clothing and wash with soap and warm water. If injected by high pressure under skin, regardless of the appearance or its size, contact a physician IMMEDIATELY. Delay may cause loss of affected part of the body.

INHALATION: Vapour pressure is very low and inhalation at room temperature is not a problem. If overcome by vapour from hot product, immediately remove from exposure and call a physician.

INGESTION: If ingested, call a physician immediately. Do not induce vomiting.

Section 5 – Fire and Explosion Hazard Data

Flash Point (Method Used) COC – 400oF **Flammable Limits** LEL 0.9% UEL 7.0%

Extinguishing Media: Foam, Dry Chemical, Carbon Dioxide or Water Spray (Fog)

Special Fire Fighting Procedures: Cool exposed containers with water. Use air-supplied breathing equipment for enclosed or confined spaces.

Unusual Fire and Explosion Hazard: Do not store or mix with strong oxidants. Empty containers retain residue. Do not cut, drill, grind or weld, as they may explode.

Document Number:	TM11183600-0013	Revision:	6	Date:	12/01/11
Created by:	R Greenfield	Checked by:	E. Taylor	Approved by:	M Innes

Section 6 – Physical/Chemical Characteristics

Boiling Point	>550oF	Specific Gravity (H2O = 1)	0.94 – 0.97
Vapour Pressure (mm Hg.)	<0.01	Melting Point	Semi-solid
Vapour Density (AIR = 1)	>5	Evaporation Rate (Butyl Acetate = 1)	<0.01
Solubility in Water	Negligible		
Appearance and Odour	Smooth, tan grease with mineral oil odour.		

Section 7 – Reactivity Data

Stability	Unstable	Conditions to Avoid	N/A
	Stable X		
Incompatibility (Materials to Avoid)	Avoid contact with s strong oxidants like liquid chlorine, concentrated oxygen.		
Hazardous Decomposition or By-products	May form SO2. If incomplete combustion. Carbon Monoxide		
Hazardous Polymerisation	May Occur		
	Will Not Occur X		
Conditions to avoid	N/a		

Section 8 – Spill or Leak Procedures

Steps to be taken in case material is released or spilled

Scrape up grease, wash remainder with suitable petroleum solvent or add absorbent. Keep petroleum products out of sewers and watercourses. Advise authorities if product has entered or may enter sewers and watercourses.

Waste disposal method

Assure conformity with applicable disposal regulations. Dispose of absorbed material at an approved waste disposal facility or site.

SARA/TITLE III, Section 313 Status – Zinc Compounds - <8%

Section 9 – Special Protection Information

Respiratory Protection (Specify type)	Normally not needed		
Ventilation	Local Exhaust	Used to capture fumes and vapours	Special N/A
	Mechanical (General)		Other N/a
Protective Gloves	Use oil-resistant gloves, if needed		
Eye Protection	If chance of eye contact, wear goggles.		
Other Protective Equipment	Use Oil-resistant apron, if needed.		

Section 10 – Special Precautions

Precautions to be taken in handling and storing

Keep containers closed when not in use. Do not handle or store near heat, sparks, flame, or strong oxidants.

Other precautions

Remove oil-soaked clothing and laundry before reuse. Cleanse skin thoroughly after contact.

The above information is furnished without warranty, expressed or implied, except that it is accurate to the best knowledge of Fiske Brothers Refining Company. The data on these sheets relates only to the specific material designated herein. Fisk Brothers Refining Company assumes no legal responsibility for use or reliance upon this data.

Document Number:	YMS1163600-0013	Revision:	0	Date:	12/01/11
Created by:	R Greenfield	Checked by:	B. Taylor	Approved by:	M Innes

HEALTH & SAFETY DATA:

DURON FOODMASTER CLEAR 2 (Information copied here, original documents available)

Fully Synthetic Food Safe Grease with PTFE Dispersion

Composition

Blend of food safe synthetic grease with PTFE dispersion.

Preparation is not classified as dangerous for supply on the basis of health effects under CHIP2.

Preparation is not subject to recognised exposure limits.

Hazards Identification

No reasonably foreseeable hazards to man or environment.

First aid Measures

- Inhalation n.a.
- Skin Wash with plenty of soap and water.
- Eyes Flush with plenty of water – if discomfort continues seek medical advice.
- Ingestion Rinse out mouth with water. Do not induce vomiting. Seek medical advice.

Fire Fighting Measures

- Extinguishing media: Sand, foam, CO2, powder.
- Combustion hazards: Fluorine compounds from decomposition of PTFE at high temperatures.
- Protective equipment: Self-contained breathing sets if large quantity of burning grease in confined space.

Accidental Release Measures

- Personal precautions: Avoid contact with skin and eyes.
- Environmental precautions: Avoid contamination of watercourses and drains.
- Methods of cleaning up: Use absorbent such as a vermiculite and sweep up into containers.

Handling and Storage

- Safe handling precautions: Normal hygiene precautions.
- Safe storage: Keep drum closed.

Exposure Controls/Personal Protection

- Exposure controls: Substance is not subject to recognised exposure limits.
- Personal protection:
 - Respiratory: n.a.
 - Hands: Wear oil resistant gloves or barrier cream if regular skin contact is expected.
 - Eyes: Wear safety glasses if there is danger of spraying.

Document Number:	TM11163600-0013	Revision:	0	Date:	12/01/11
Created by:	R Greenfield	Checked by:	E. Taylor	Approved by:	M Innes

(Duron Foodmaster Clear 2 cont'd)

Physical and Chemical Properties

Appearance: Clear Paste
 Odour: none
 PH: n.a
 Flash point: >235°C
 Drop point: none melting
 Relative density: 0.98
 Solubility in water: insoluble
 Kinematic viscosity: NLGI No 2 Grease

Stability and Reactivity

Conditions to avoid: No specific conditions
 Materials to avoid: Strong oxidising agents
 Hazardous decomposition: PTFE component may release fluorine compounds above 300 °C

Toxicological Information

Non toxic.
 Low order of irritancy.
 May act as mild laxative if swallowed.

Ecological Information

Not available.

Disposal Considerations

Disposal of virgin product should present no hazard. Do not incinerate. Used product may be contaminated with metal particles or other contaminants arising from the particular application for which the product has been used. Any method of disposal must take into account the contaminant present. The product may be disposed of via an authorised person/licensed waste disposal contractor.
 All means of disposal should comply with local regulations and (in the UK) the Environmental Protection Act 1990. Dispose of product and containers carefully and responsibly. Do not allow product to contaminate ponds, water courses, solid or drains.
 Do not re-use empty containers. Offer for recycling, reconditioning, or puncture to be disposed of in an approved land-fill site.

Transportation Information

Product is classified as **non-hazardous** under "Carriage of Dangerous Goods by Road and Rail" (Classification, Packaging and Labelling) Regulations 1994

Class: n.a.
 Packaging Group: n.a.

Regulatory Information

CHIP2 Classification

This preparation is non hazardous and therefore falls outside the requirements of the CHIP2 Regulations. It is good working practice however to avoid contact with the skin and eyes.

The classification shown above does not remove the requirement for the user to conduct a Workplace risk assessment as required by COSHH.

Document Number:	TM11183600-0013	Revision:	0	Date:	12/01/11
Created by:	R Greenfield	Checked by:	B. Taylor	Approved by:	M Jones

HEALTH & SAFETY DATA:

DURON MULTIP 2 (Information copied here, original documents available)

High Performance Lithium No 2 Grease with Zonyl PTFE from Du Pont

Composition

Blend of high purity mineral oil grease with Teflon dispersion, moisture displacement agents and corrosion inhibitors
 Preparation is not classified as dangerous for supply on the basis of health effects under CHIP2.
 Preparation is not subject to recognised exposure limits.

Hazards Identification

No reasonably foreseeable hazards to man or environment.

First aid Measures

Inhalation n.a.
 Skin Wash with plenty of soap and water.
 Eyes Flush with plenty of water – if discomfort continues seek medical advice.
 Ingestion Rinse out mouth with water. Do not induce vomiting. Seek medical advice.

Fire Fighting Measures

Extinguishing media: Sand, foam, CO2, powder.
 Combustion hazards: Fluorine compounds from decomposition of Teflon at high temperatures.
 Protective equipment: Self contained breathing sets if large quantity of burning grease in confined space.

Accidental Release Measures

Personal precautions: Avoid contact with skin and eyes.
 Environmental precautions: Avoid contamination of water courses and drains.
 Methods of cleaning up: Use absorbent such as a vermiculite and sweep up into containers.

Handling and Storage

Safe handling precautions: None required
 Safe storage: Keep drum closed.

Exposure Controls/Personal Protection

Exposure controls: Substance is not subject to recognised exposure limits.
 Personal protection:
 Respiratory: n.a.
 Hands: Wear oil resistant gloves or barrier cream if regular skin contact is expected.
 Eyes: Wear safety glasses if there is danger of spraying.

Physical and Chemical Properties

Appearance: Light brown smooth grease
 NLGI Classification 2
 Thickner Lithium - Calcium
 Dropping Point: 180°C min. ASTM D566

Document Number:	TM11 1B3600-0013	Revision:	0	Date:	12/01/11
Created by:	R Greenfield	Checked by:	B. Taylor	Approved by:	M Innes

(Duron Multip 2 cont'd)

Stability and Reactivity

Conditions to avoid: No specific conditions
 Materials to avoid: No specific materials
 Hazardous decomposition: Teflon component may release fluorine compounds above 300 °C

Toxicological Information

Current data does not indicate any delayed or immediate toxicological effects from short-term exposure.
 Long term skin contact may cause dermatitis.

Ecological Information

Contains mineral oil. Will not readily biodegrade.

Disposal Considerations

Disposal of virgin product should present no hazard. It may be treated as waste oil. Used product may be contaminated with metal particles or other contaminations arising from the particular application for which the product has been used. Any method of disposal must take into account the contamination present. The product may be disposed of via an authorised person/licensed waste disposal contractor.

All means of disposal should comply with local regulations and (in the UK) the Environmental Protection.

Act 1990. Dispose of product and containers carefully and responsibly. Do not allow product to contaminate ponds, water courses, solid or drains.

Do not re-use empty containers. Offer for recycling, reconditioning, or puncture to be disposed of in an approved land-fill site.

Transportation Information

Product is classified as **non-hazardous** under "Carriage of Dangerous Goods by Road and Rail" (Classification, Packaging and Labelling) Regulations 1994

Class: n.a.

Packaging Group: n.a.

Regulatory Information

CHIP2 Classification

This preparation is non hazardous and therefore falls outside the requirements of the CHIP2 Regulations. It is good working practice however to avoid contact with the skin and eyes.

The classification shown above does not remove the requirement for the user to conduct a Workplace risk assessment as required by COSHH.

Document Number:	TM11183690-0013	Revision:	0	Date:	12/01/11
Created by:	R Greenfield	Checked by:	B. Taylor	Approved by:	M Innes

OVERALL LENGTH 647.05 [25.474 in]

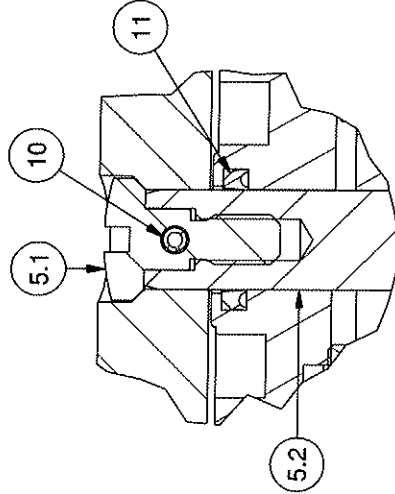
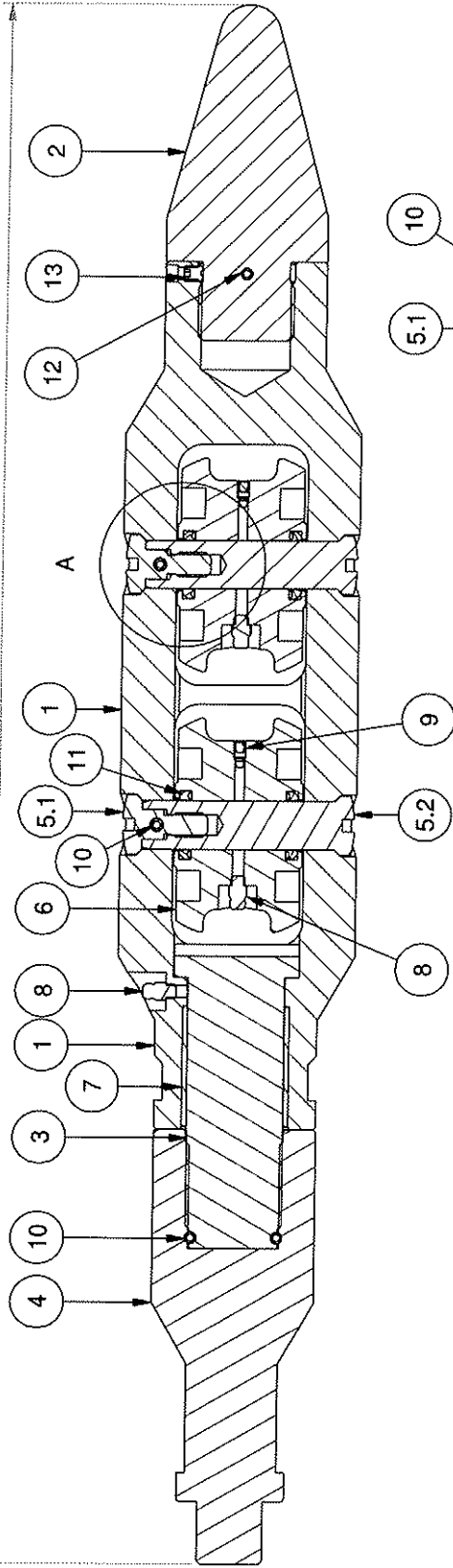

DETAIL A

Parts List			
Item	Part Number	Description	Qty
1	11183850-0101	Main Body	1
2	11183850-0301	Bottom Sub	1
3	11183850-0601	Rotating End Pin	1
4	11183850-0801	Top Sub	1
5	11183850-0076	Roller Pin / Retaining Head	2
5.1	11183600-0806	Roller Pin Retaining Head	1
5.2	11183850-0406	Roller Pin	1
6	11183850-0503	Roller	2
7	84750000-0499	Linear Bearing	1
8	84620006-0299	Grease Nipple	3
9	84640187-0199	Screen	2
10	84100187-0399	Roll Pin 2" Long	4
11	83980020-0299	Wiper Seal 20mm	4
12	84100187-0499	Roll Pin 2.5" Long	1
13	84000250-0205	Soc Head Set Screw	1

DESIGN SPECIFICATION	
Service	SOUR
Top Connection	1-1/16in -10 UN SR Pin
Bottom Connection	-
Fishneck	1.75in
Max O/D	3.850in
Make Up Length	621.05mm [24.45in]
Weight	10.12kg [22.26 lbs] (CAD)



Material Spec:	X ± 0.5	T.I.R.	0.15	Checked By:	R Greenfield	Description:	3.850in Guide Roller Bogie
Coating Spec:	X.X ± 0.25	Corner Radii	0.80	Drawn By:	B. Taylor	Sheet No.:	1 of 1
Marking Spec:	X.XX ± 0.15	Chamfer	0.25 x 45°	Approved By:	M Innes	Approved Date:	01-Dec-10
Sht Size:	MS-01	Finish	1.6/	Project No.:	8164	Part No.:	11183850-0013
		Angle	± 0.50°			Rev:	0
		Thread Back	30°				

UNLESS OTHERWISE STATED

Copyright, all rights reserved. This drawing approved date applies. This drawing and the information contained herein is the sole and exclusive property of Wireline Engineering Ltd. This drawing must not be reproduced or distributed in any form or by any means, or stored in a database or retrieval system, in whole or in part, without the prior and express written permission of Wireline Engineering Ltd.

Remove all burrs and sharp edges.
All dimensions in millimeters (U.O.S.)