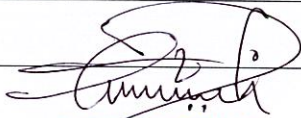

SLICKLINE ASSISTANT WORKBOOK

IMPORTANT NOTE:

1. Your point of reference to complete this workbook may be obtained from the following
 - Training Manual and any other training materials provided together with this workbook
 - Your Trainer, Assessor (Slickline Operator), Verifier (FSM) or senior colleagues
 - SOP / Quality Procedures & Processors
2. The completion of this Workbook is a joint effort and responsibility between you and your assessor therefore you have the obligation to request from your assessor to be assessed upon your completion of each topic
3. The completion of this Workbook is part of the MANDATORY requirements which you must fulfill to qualify for a promotion
4. Your training program is mostly self-driven, including this Workbook. It requires individual initiatives, dedication and commitment to complete the process.

NAME	SEAMUS SAGING	 GAZALI MEHRY Operation Manager Dimension Bid (M) Sdn Bhd Labuan Warehouse Slickline Services
DATE OF JOIN	15.04.2024	
CONTACT NO.	014-9984803	
RECEIVED DATE	05.02.2025	
DATE COMPLETED	05.03.2025	

7/3/25



B. SURFACE EQUIPMENT

B.1. STUFFING BOX

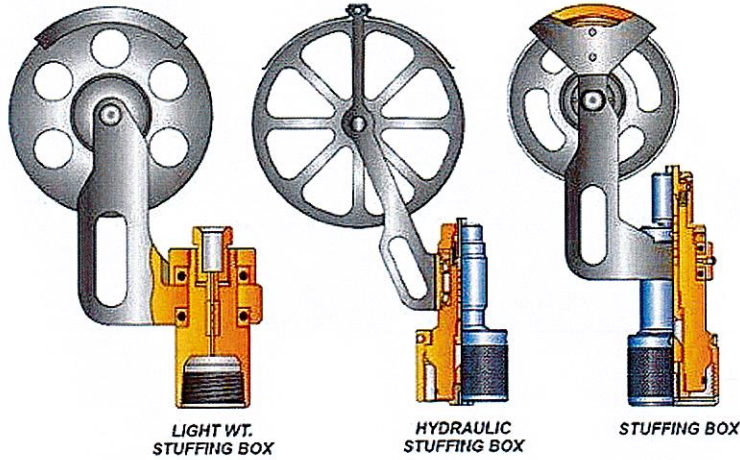

What is Stuffing Box

A primary pressure barrier that positioned at the uppermost point of the PCE string. Stuffing box available for a full range of wire sizes, and from 5,000 psi to 15,000 psi working pressures.

✓

What is the purpose of stuffing Box

The purpose of the stuffing box is to prevent the leakage of well fluids such as oil, gas, or water while the wireline cable moves in and out of the well.

✓

How to operate Stuffing Box

Stuffing box can be operated either manually or hydraulically without part modification.

✓

GAZALI MERRY
Operation Manager
Dimension Bid (M) Sdn Bhd
Labuan Warehouse
Slickline Services

7/3/25



What is maintenance required for Stuffing Box

1. **Packings** : Not worn out. ✓
2. **Sheave** : Use correct size ✓
3. **Upper and lower gland** : Check for wear ✓
4. **BOP plunger** : Check for wear and freedom of vertical movement ✓
5. **Sheave bearings** : Check for free spinning ✓
6. **Sheave staff** : Check for freedom of swivel movement ✓
7. **Sheave guard** : Tight and adjusted close to the sheave ✓

What is safety precaution required for Stuffing Box

Check the packings are not worn out, check the sheave is the correct size, check the upper and lower brass packing glands for wear, check the sheave bearings for free spinning and side play, check the sheave staff for freedom of swivel movement, check the BOP plunger for wear and freedom of vertical movement ✓

What is potential hazard during handling Stuffing Box

1. Back injury ✓
2. Pinch point ✓
3. Drop object ✓

GAZALI MEHRY
Operation Manager
Dimension Bid (M) Sdn Bhd
Labuan Warehouse
Slickline Services

7/2/25



Draw & name each part of stuffing box

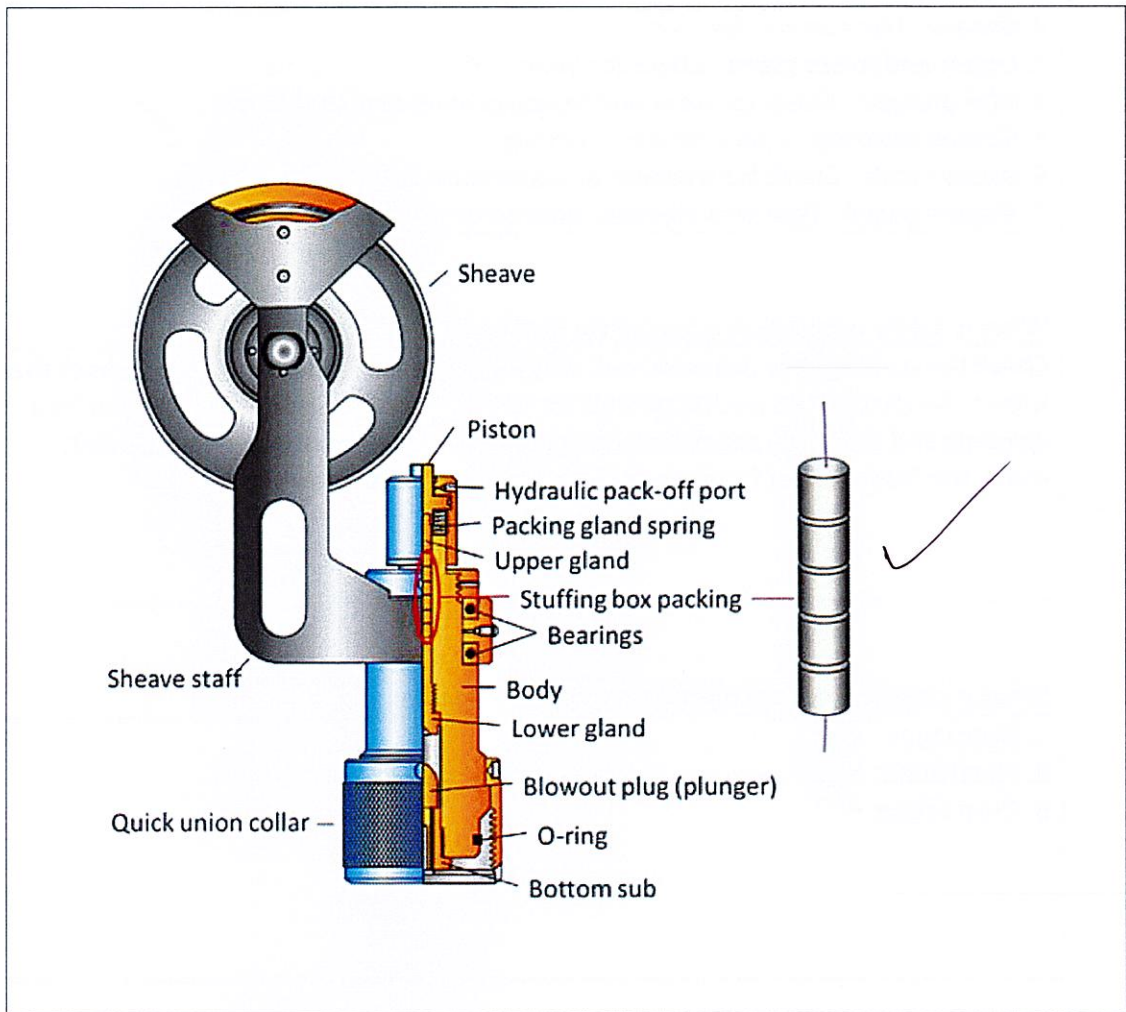

GAZALI WENNY
Operation Manager
Dimension Bid (M) Sdn Bhd
Labuan Warehouse
Slickline Services

7/2/25

B.2. LUBRICATOR

What is Lubricator

Lubricator is also known as risers are series of inter-connected lengths of pipe. It is a piece of equipment designed to enable wireline tool string to be introduced or retrieve from a wellbore under pressure. ✓

What is the purpose of Lubricator

The purpose of stuffing box is to provide a space for the tool to be contained in under pressure, when opening and closing the wellhead. ✓

How to operate Lubricator

The lubricator section can be connected by using a chain block, wireline mast, crane, or gin pole. ✓

What is maintenance required for Lubricator

1. Check for any cracks.
2. Visually inspect at the regular interval.
3. Check all the o-ring and make sure that it didn't worn out. ✓

What is safety precaution required for Lubricator

The lubricator should be x-rayed, and one of the lubricators must have a port to bleed off pressure. ✓

GAZALI MEHRY
Operation Manager
Dimension Bid (M) Sdn Bhd
Labuan Warehouse
Slickline Services

7/3/25



What is potential hazard during handling Lubricator

- 1. Back injury ✓
- 2. Pinch point ✓
- 3. Drop object ✓

Draw & name each part of Lubricator

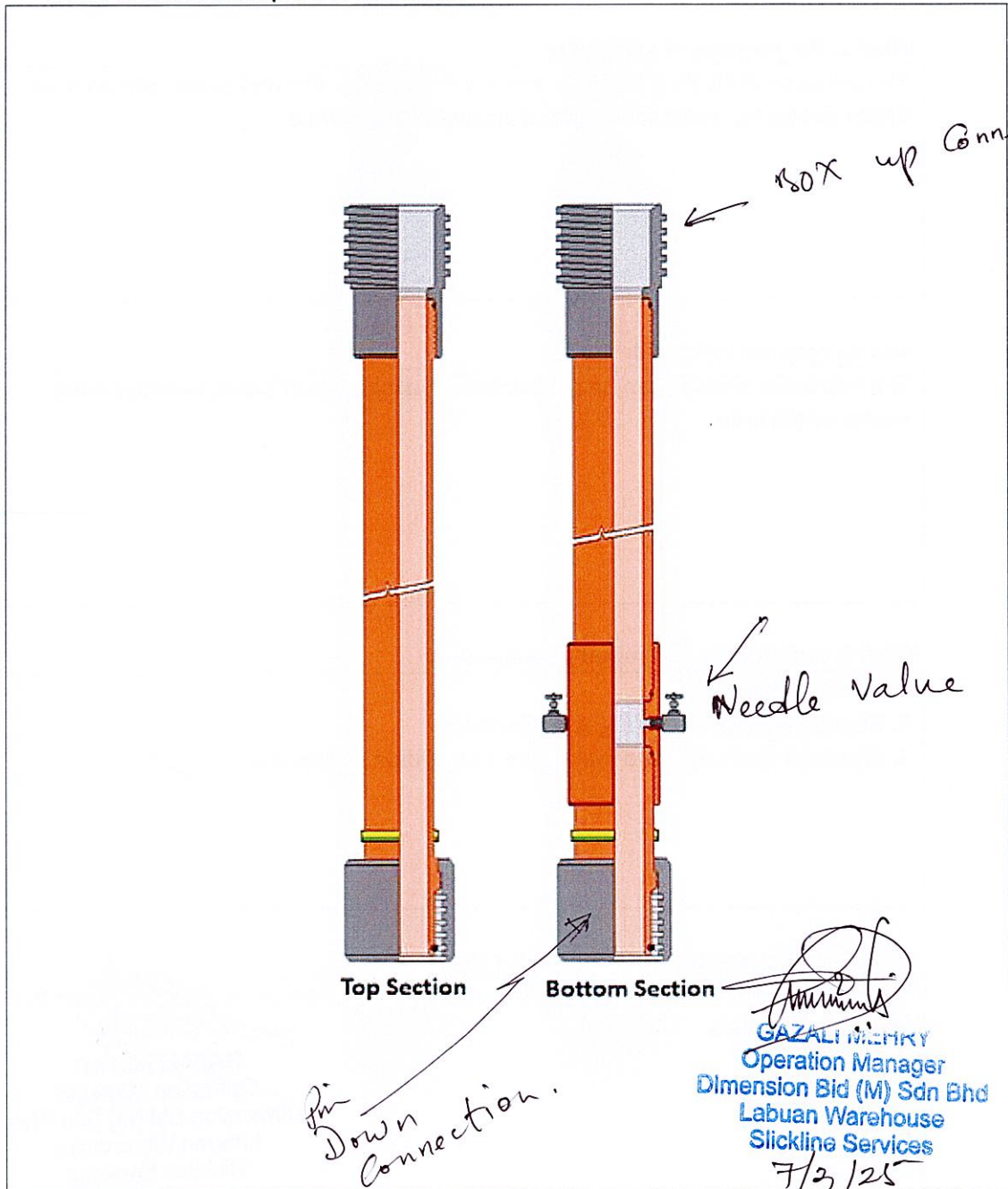

[Signature]
GAZALI NICKY
Operation Manager
Dimension Bid (M) Sdn Bhd
Labuan Warehouse
Slickline Services
7/3/25



B.3. BLOWOUT PREVENTER (BOP)

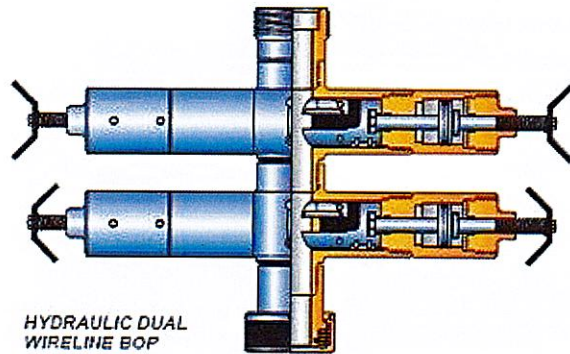

HYDRAULIC DUAL WIRELINE BOP

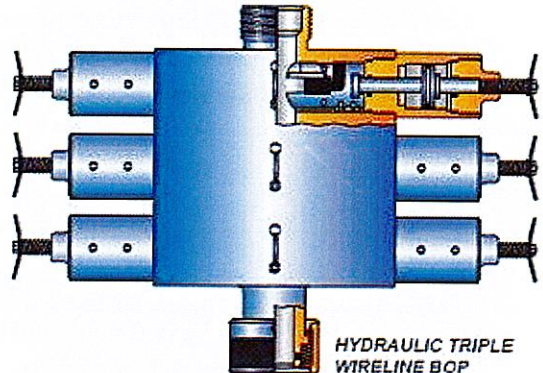

HYDRAULIC TRIPLE WIRELINE BOP

What is BOP

A BOP also known as a wireline valve is installed between the tree connection and lower lubricator section. ✓

What is the purpose of BOP

1. To enable the well pressure to be isolated without cutting the wire by closing the master valve. ✓
2. Permit the assembly of the wireline cutter above the BOP rams and dropping it if the toolstring becomes stuck in the well. ✓
3. Allow slickline work under the well pressure on surface equipment, while wire in the wellbore. ✓

How to operate BOP

1. Hydraulically by using RSU and control panel. ✓
 - With the rams open - Pressure to 150% of the working pressure ✓
 - With the rams closed - Pressure to 100% of the working pressure to test the ram seal against the wire diameter ✓

GAZALI MEHRY
Operation Manager
Dimension Bid (M) Sdn Bhd
Labuan Warehouse
Slickline Services

7/3/25



What is maintenance required for BOP

1. Must be service and need to be pressure tested ✓
 - Level 1 Service - To be carried out after every job. ✓
 - Level 2 Service - To be carried out once a year. ✓
 - Level 3 Service - To be carried out every 5 years. ✓

What is safety precaution required for BOP

Ensure that the rod has an enlarged diameter below the ram to prevent it from being blown out during testing. ✓

What is potential hazard during handling BOP

1. High pressure ✓
2. Back injury ✓
3. Hose burst ✓

GAZALI MEHRY
Operation Manager
Dimension Bid (M) Sdn Bhd
Labuan Warehouse
Slickline Services

GAZALI MEHRY
Operation Manager
Dimension Bid (M) Sdn Bhd
Labuan Warehouse
Slickline Services
7/3/25



Draw & name each part of BOP

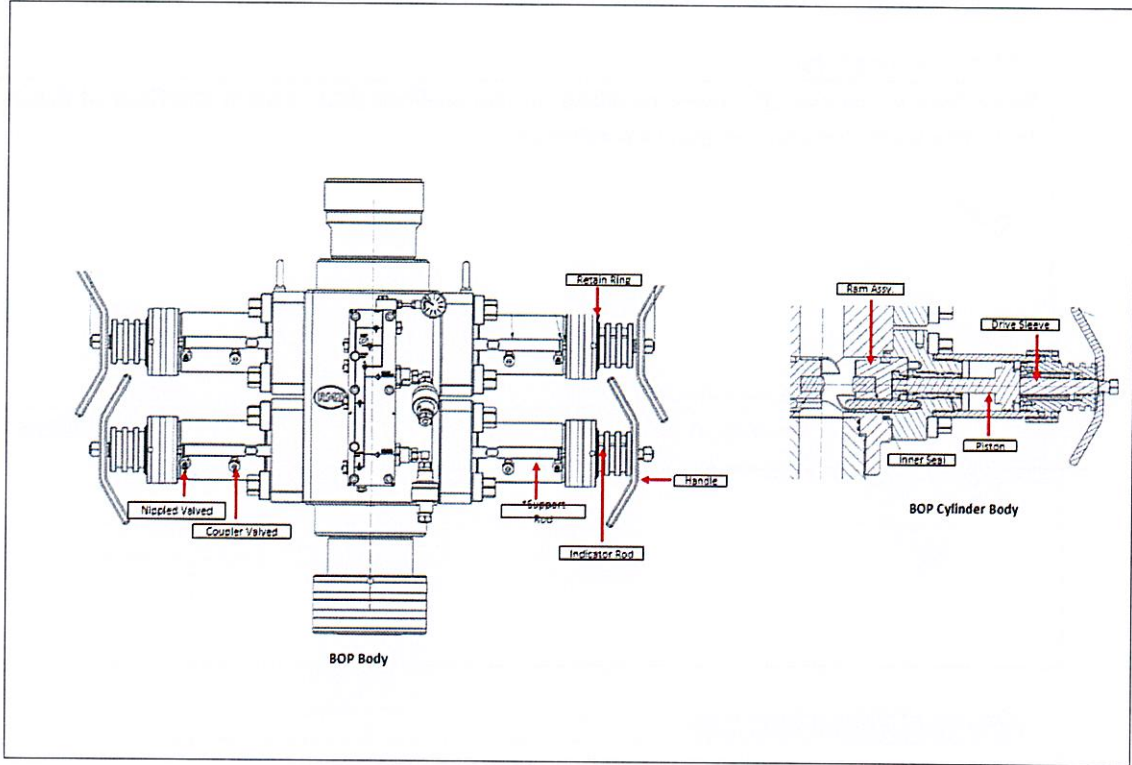

GAZALI MEHRY
Operation Manager
Dimension Bid (M) Sdn Bhd
Labuan Warehouse
Slickline Services

B.4. X-MAS TREE

What is x-mas tree

Xmas tree is a series of valves installed on the wellhead to control the flow of fluids from the well. Located on top of wellhead.

✓

What is the purpose of x-mas tree

Christmas trees are a vertical assembly of valves with gauges and chokes that allow for adjustments in flow control as well as injections to stimulate production.

✓

How to operate x-mas tree

The valves that comprise some of the decorations on the Christmas tree are opened when the oil or gas well is ready to produce and the processing and storage facilities are ready to receive. ✓

What is maintenance required for x-mas tree

1. Inspect and replace any damaged component ✓
2. clean X-mas tree and ✓
3. Do Critical Device Function Test (CDFT) on X-mas tree (check all valves) ✓

What is safety precaution required for x-mas tree

1. Make a count during opening and closing the swab valve. ✓
2. Do not over-tightened the valves during operation and closing. ✓
3. Never use master valve to shut in the flowing well, except in an emergency situation. (use swab or wing valve) ✓

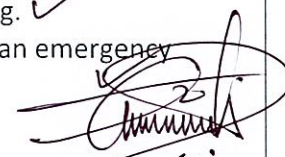

GAZALI MEHRY
Operation Manager
Dimension Bid (M) Sdn Bhd
Labuan Warehouse
Slicking Services



What is potential hazard during handling x-mas tree

- 1. Pinch point ✓
- 2. High pressure ✓
- 3. Work under suspended load ✓
- 4. Line of fire ✓

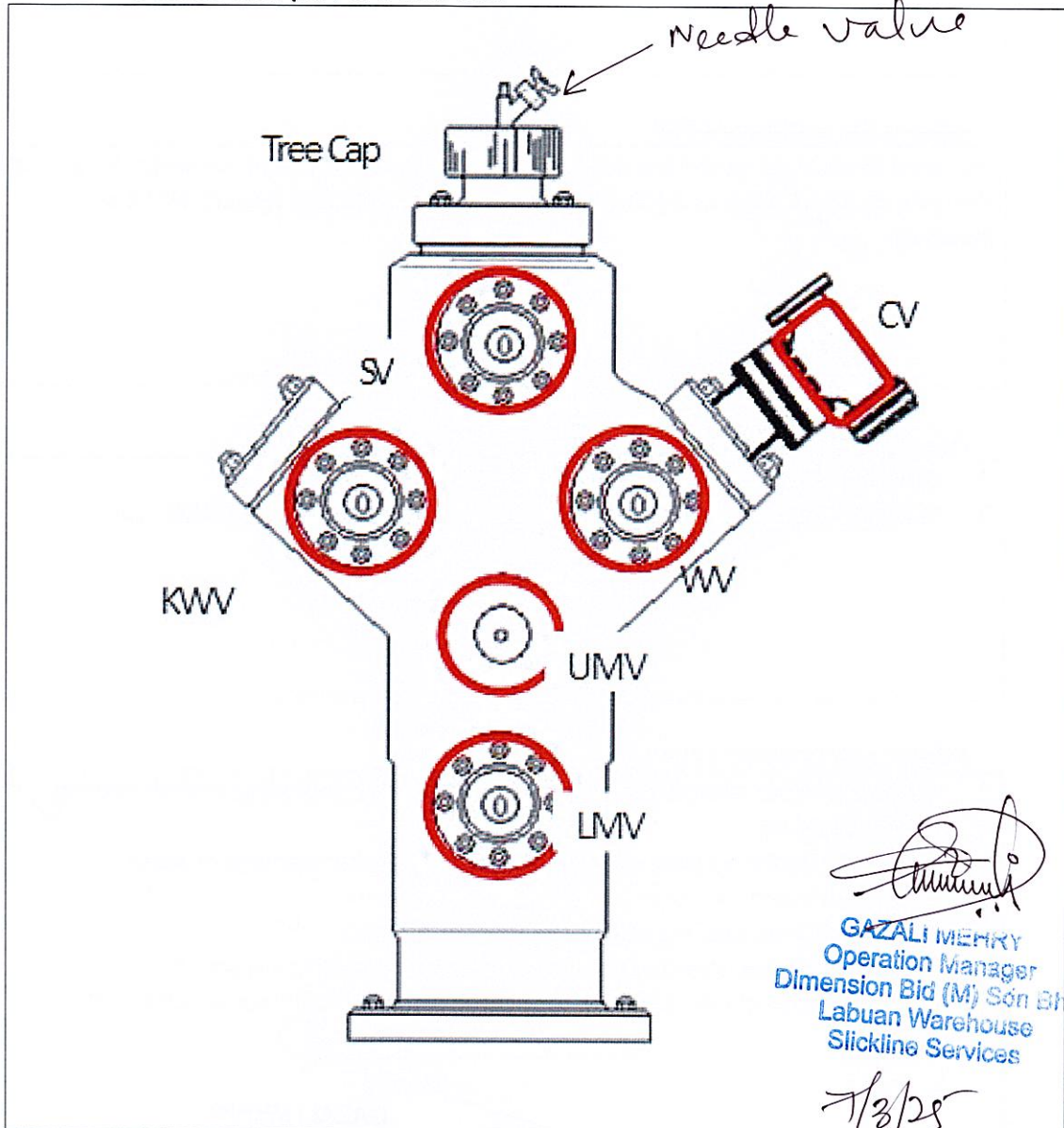
Draw & name each part of x-mas tree



[Signature]
GAZALI MEMRY
Operation Manager
Dimension Bid (M) Sdn Bhd
Labuan Warehouse
Slickline Services

7/3/25



B.5. WIRELINE REEL SKID UNIT (RSU) / WINCH – SINGLE DRUM AND DOUBLE DRUM

What is RSU

RSU is also known as a wireline unit or winch, which can control the wireline tool string to go into the well (RIH) or pull the tool string out of the well (POOH). ✓

What is the purpose of RSU

It is used to convey downhole equipment or tools in and out of the wells. It can turn the wire drum to lower and rise tool strings in the wells that require wireline servicing. ✓

How to operate RSU

1. By using power pack and winch hydraulic system ✓
2. Transmission of hydraulic line via line between power pack / RSU ✓

What is maintenance required for RSU

1. Inspect all filter indicators to ensure that they are operating in their normal working region. ✓
2. Inspect all hydraulic pipe work, hoses and fittings for damage or leaks. ✓
3. Inspect all hydraulic valves for damage or leaks. ✓
4. Inspect all structural aspects of the unit for damage. ✓
5. All grease nipples should be greased after every 10 hours work. ✓
6. The main drive chain should be lubricated after every 20 hours work. ✓

GAZALI MEHRY
Operation Manager
Dimension Bid (M) Sdn Bhd
Labuan Warehouse
Slickline Services

7/3/25

What is safety precaution required for RSU

Be aware with the wire and rotating drum winch when operating, as it might break.

What is potential hazard during handling RSU

1. Winch Brake Failure ✓
2. Pinch point ✓
3. Rotating drum winch ✓
4. Hydraulic Leaks ✓
5. Cable Breakage ✓

[Signature]
GAZALI MEHRY
Operation Manager
Dimension Bid (M) Sdn Bhd
Labuan Warehouse
Slickline Services

Draw & name each part of RSU

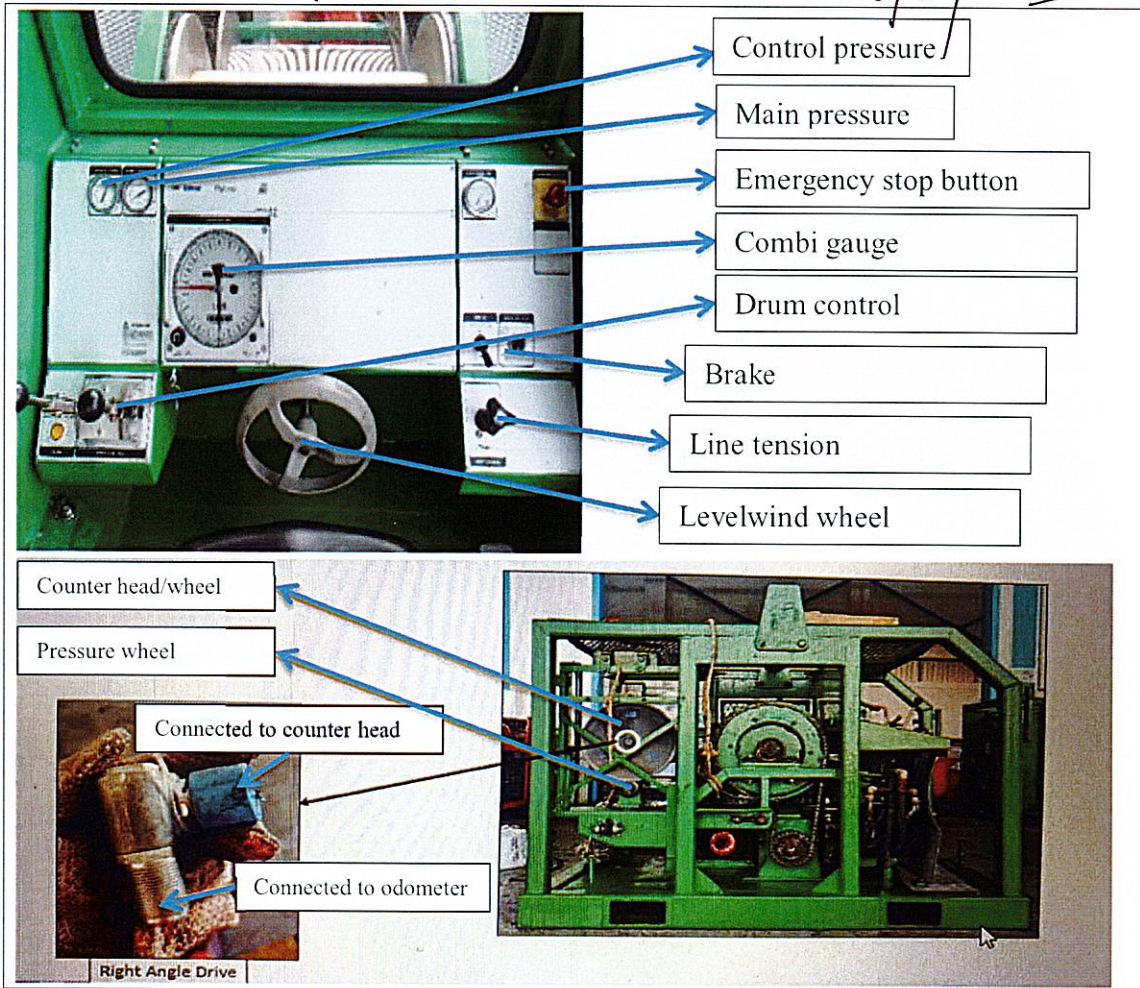



B.6. ODOMETER

What is Odometer

Odometer is a depth measuring device and also known as depth counter

What is the purpose of Odometer

Used to indicate wireline toolstring depth in in the hole in feet or meters unit.

How to operate Odometer

Prior to operation, this device should be manually set to zero and start reading from tubing hanger. Connect hose to right angle drive and put odometer to RSU for monitoring puposes.

What is maintenance required for Odometer

1. Calibrate the Odometer
2. Drive cable transmit the depth measurement rotary movement to the depth counter

GAZALI MEHRY
Operation Manager
Dimension Bid (M) Sdn Bhd
Labuan Warehouse
Slickline Services

7/3/25

What is safety precaution required for Odometer

Wear appropriate PPE ✓

What is potential hazard during handling Odometer

1. Sharp edges ✓
2. Pinch point ✓

Draw & name each part of Odometer

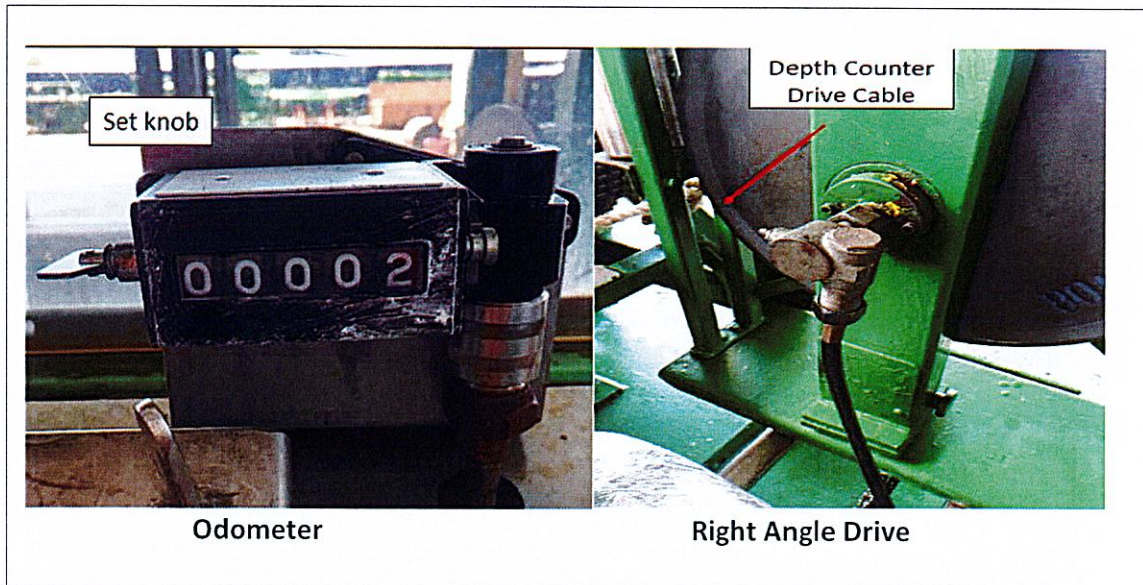

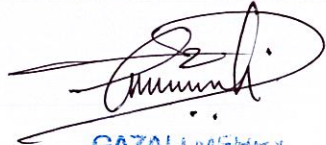
GAZALI MEHRY
Operation Manager
Dimension Bid (M, Son St.)
Labuan Warehouse
Slickline Services

7/3/25

B.7. WEIGHT INDICATOR (2000 LBS AND 4000 LBS)

What is Weight Indicator

It measures the weight of the tool string or equipment being lowered into or raised from the wellbore. This measurement is essential to ensure that the right amount of weight is applied to the tool.

✓

What is the purpose of Weight Indicator

To allow the total weight of the tool string hung at the end of the wire to be read and reflected by weight indicator.

✓

How to operate Weight Indicator

The weight indicator (located at RSU) is connected to the load cell using a rubber hose filled with hydraulic oil.

✓

What is maintenance required for Weight Indicator

It is necessary to completely flush and re-charge the unit at least once per month.

- Check for leaks around the hose and priming check valve assembly.
- Check the level of clear glycerin vibration dampening fluid inside the gauge face, should be nearly full.
- If additional "W-15" fluid is required, fill through the small port on the upper side of the gauge housing.
- Reset the dial face with zero under the needle with no load on cell.

What is safety precaution required for Weight Indicator

- Do not damage the hose
- Secure gauge and fittings
- Handle with care
- Protect from Vibrations or Shocks

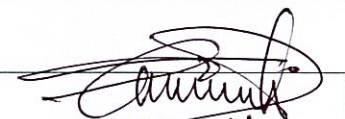
GAZALI MEHRY
Operation Manager
Dimension Bid (M) Sdn Bhd
Labuan Warehouse
Slickline Services

7/3/25



What is potential hazard during handling Weight Indicator

1. Drop object
2. If proper attention is not given to the weight indicator during operation, it may result in excessive tension, which could cause the wire to break.

Draw & name each part of Weight Indicator

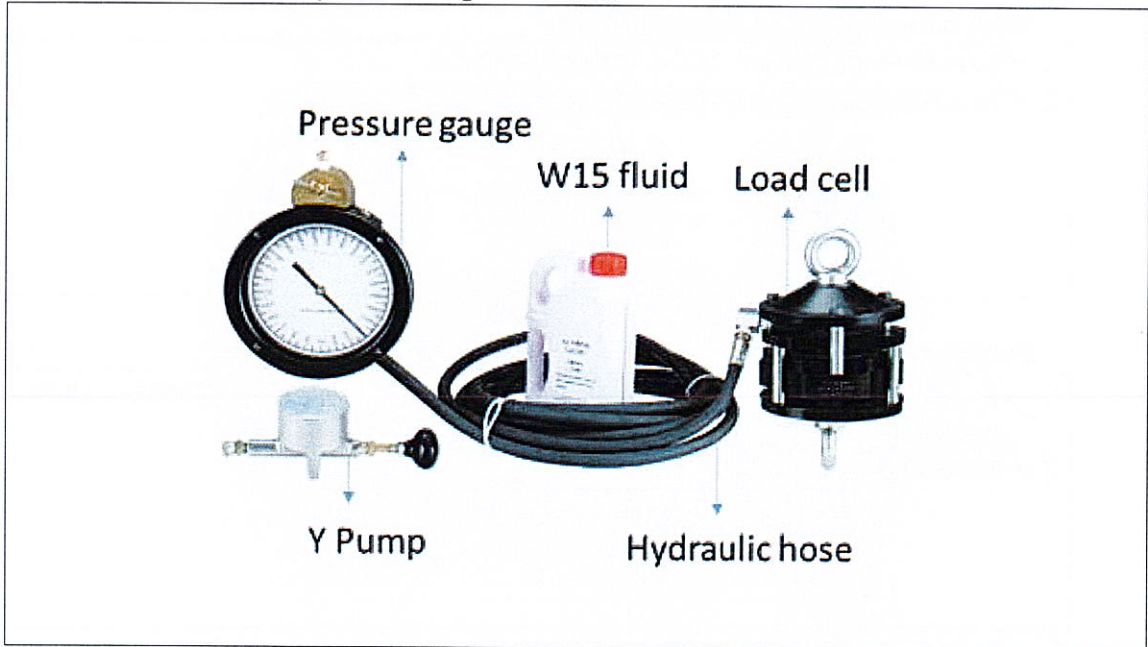

GAZALI MEHRY
Operation Manager
Dimension Bid (M) Sdn Bhd
Labuan Warehouse
Slickline Services
7/3/25

B.8. SPOOLING DEVICE

What is Spooling Device

One configured with removable drum that allow transport spools to be inserted, allowing the new string to be spooled into reel

What is the purpose of Spooling Device

1. ✓ To hold the reel drum during spooling process.
2. ✓ To control the tension of the line as it is spooled

How to operate Spooling Device

1. ✓ Assemble the reel. The setup is almost the same with normal operation, which weight indicator and hay pulley are needed
2. ✓ Brake level will help to control the line tension.

What is maintenance required for Spooling Device

1. ✓ Brake maintenance
2. ✓ Always check the hydraulic system

What is safety precaution required for Spooling Device

1. ✓ Make sure to check the glass in good condition before start the job.
2. ✓ Bolts and nuts (shaft) are in good condition

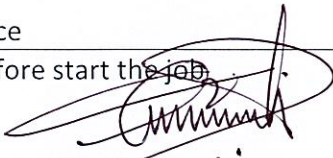

GAZALI MEHRY
Operation Manager
Dimension Bid (M) Sdn Bhd
Labuan Warehouse
Slickline Services



What is potential hazard during handling Spooling Device

1. Pinch point
2. Rotating device

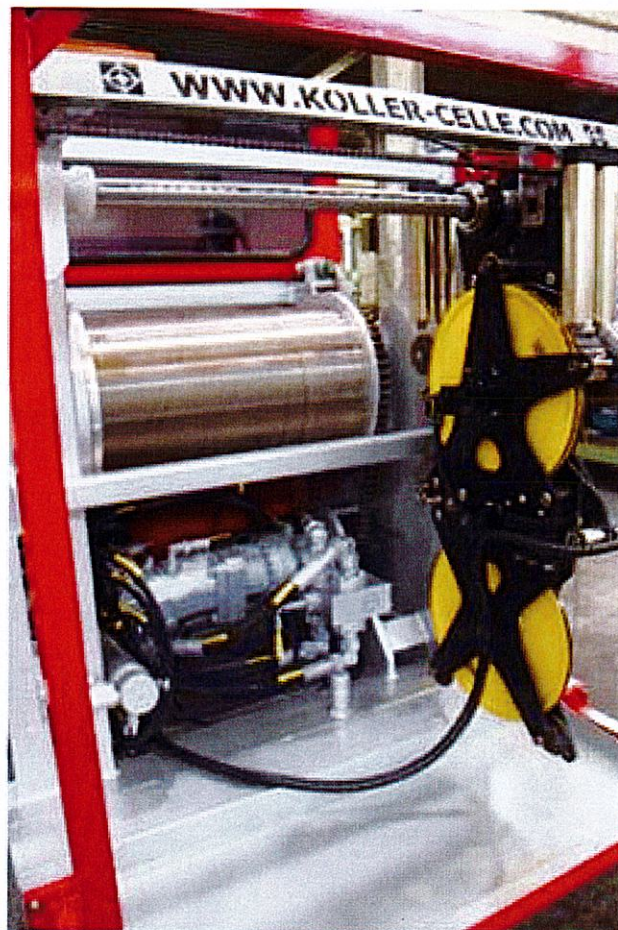
Draw & name each part of Spooling Device

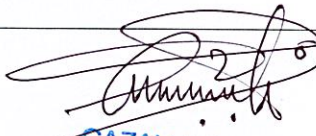

GAZALI MEHRY
Operation Manager
Dimension Bid (M) Sdn Bhd
Labuan Warehouse
Slickline Services
7/8/25

B.9. CONTROL PANEL

What is Control Panel

Device used to operate BOP, safety valve and other PCE equipment.

✓

What is the purpose of Control Panel

Control Panels are used to operate a number of valves normally operated in slickline operations. Their types and its functions are:

- ✓ Control Panel (CP) – To operate BOP rams
- ✓ Single Well Control Panel (SWCP) – To operate Master Valve and SCSSV
- ✓ Well Control Panel (WCP) – An integrated CP that can operate BOP, Stuffing Box, MV & SCSSV

How to operate Control Panel

1. ✓ Connect the control line to the equipment
2. ✓ Open air supply, use regulator to control pump out pressurized the line.

What is maintenance required for Control Panel

1. ✓ Check the fluid level of hydraulic oil
2. ✓ Check the hydraulic hoses for any sign of leakage or damage.

What is safety precaution required for Control Panel

1. ✓ Do not tighten or loose the connection when under pressure.
2. ✓ Beware of trapped pressure by bleed off fully before open connection.

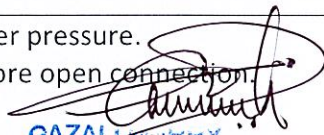
GAZAL MERRY
Operation Manager
Dimension Bid (M) Sdn Bhd
Labuan Warehouse
Slickline Services

7/3/25



What is potential hazard during handling Control Panel

1. Connection loosens
2. Hose burst by high pressure

Draw & name each part of Control Panel



Well control Panel (WCP)

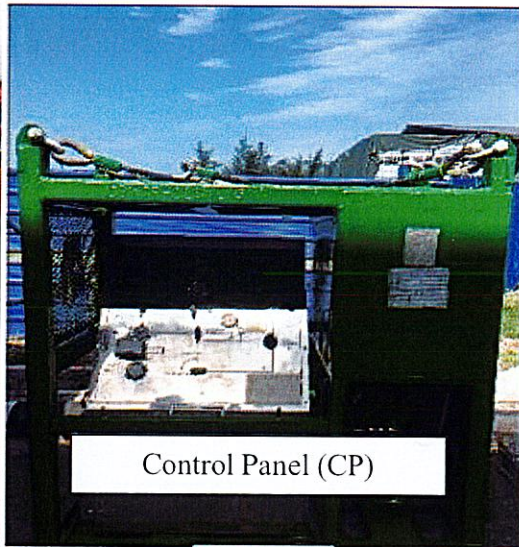

Control Panel (CP)

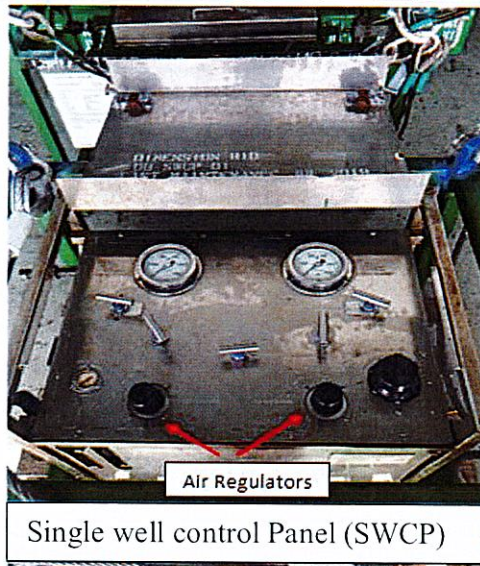

Air Regulators

Single well control Panel (SWCP)

GAZALI MEHRY
Operation Manager
Dimension Bid (M) Sdn Bhd
Labuan Warehouse
Slickline Services

B.10. HUSKEL DRUM

What is Huskel Drum

Huskel is an air driver pump. ✓

What is the purpose of Huskel Drum

Purpose of Huskel drum is to drive the hydraulic or water in control panel or test pump. ✓

How to operate Huskel Drum

Operate from the knob or regulator of the panel. ✓

What is maintenance required for Huskel Drum

1. Check the condition of the O-ring. ✓
2. Service haskel pump. ✓
3. Hydraulic check valve and liquid seal repair. ✓

What is safety precaution required for Huskel Drum

1. Check O-ring condition. ✓
2. Make sure connection tubing is in good condition. ✓

GAZALI MEHRY
Operation Manager
Dimension Bid (M) Sdn Bhd
Labuan Warehouse
Slickline Services



What is potential hazard during handling Huskel Drum

- 1. Pinch point ✓
- 2. Tubing burst ✓

GAZALI MCHRY
Operation Manager
Dimension Bid (M) Sdn Bhd
Labuan Warehouse
Sickline Services

7/3/25

Draw & name each part of Huskel Drum

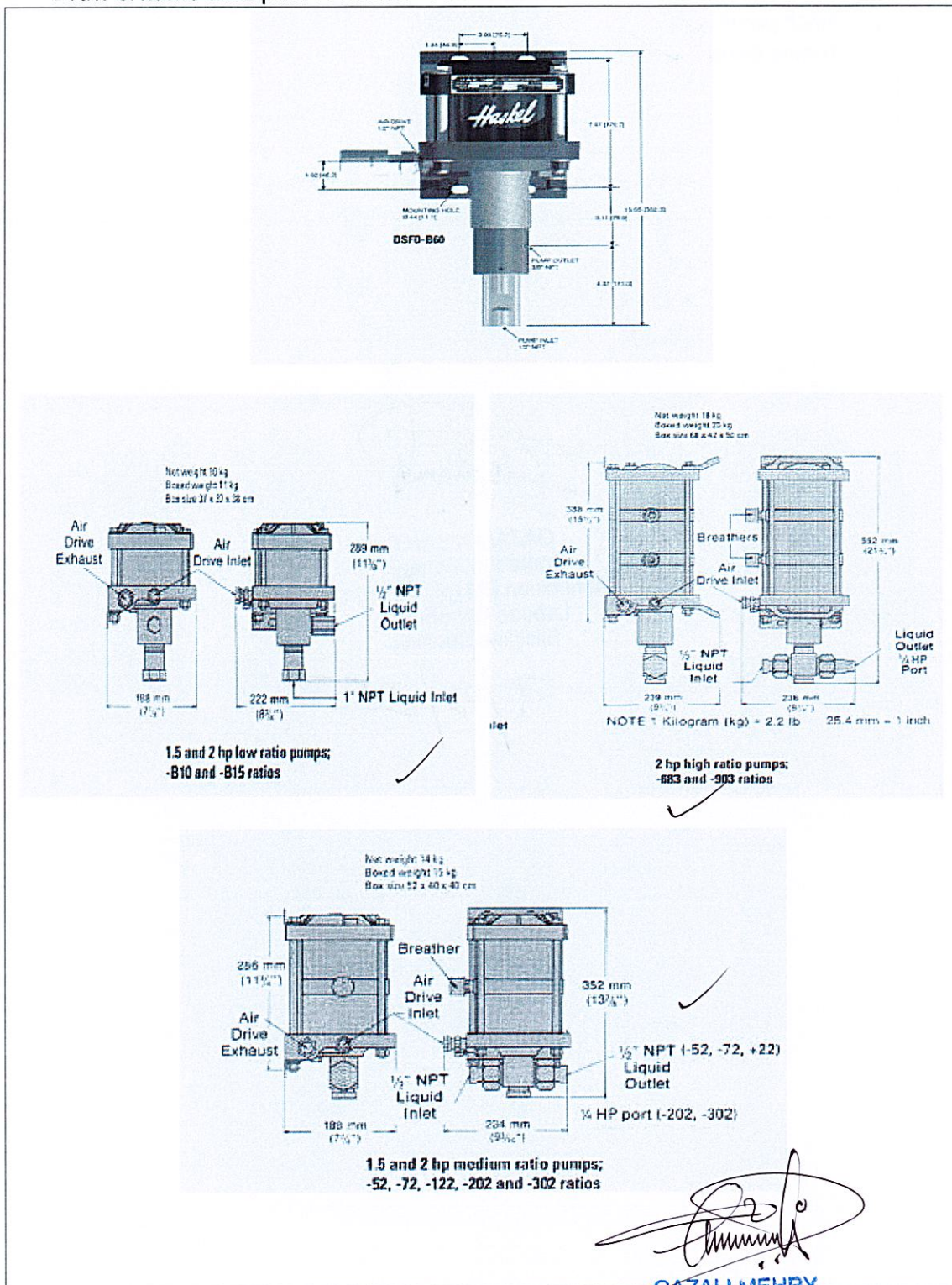

(Signature)
GAZALI MEHRY
Operation Manager
Dimension Bid (M) Sdn Bhd
Labuan Warehouse
Slickline Services
7/3/25



B.11. POWER PACK (ELECTRICAL & DIESEL)

What is Power Pack

Power pack unit is an open loop hydraulic single piece configuration which are used to power up RSU and wireline mast (if has auxiliary pump installed).

What is the purpose of Power Pack

1. Provide power to drive the hydraulic oil through a special hose/hydraulic hose to the drum at the winch.
2. Provide the power (hydraulic) to RSU

How to operate Power Pack

1. Set diesel cut off valve to 'Start' position.
2. Pump the power pack until the pressure reaches 2,000 – 3,000 psi.
3. Pull and hold inlet over speed shut down valve.
4. Step on the foot/pedal starter switch.
5. Keep and continue holding the inlet over speed shut down valve (approx. 10 sec.) until oil pressure is built.
6. Release the inlet over speed shut down valve.
7. By operating several valves, adjust speed, power and rotation of drum

What is maintenance required for Power Pack

1. Check oil level
2. Check water level
3. Check diesel level
4. Check condition of belting
5. Check any leaking

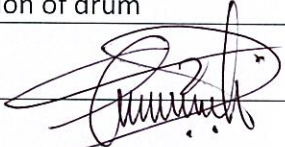
GAZALI MEHRY
Operation Manager
Dimension Bid (M) Sdn Bhd
Labuan Warehouse
Slicking Services

7/3/25

What is safety precaution required for Power Pack

1. Wear appropriate PPE when changing hydraulic oil/engine oil
2. Beware of rotating fan when engine is running
3. Do not open radiator cap while power pack is still running

What is potential hazard during handling Power Pack

1. Hose burst
2. Hand injury
3. Rotating fan

Draw & name each part of Power Pack

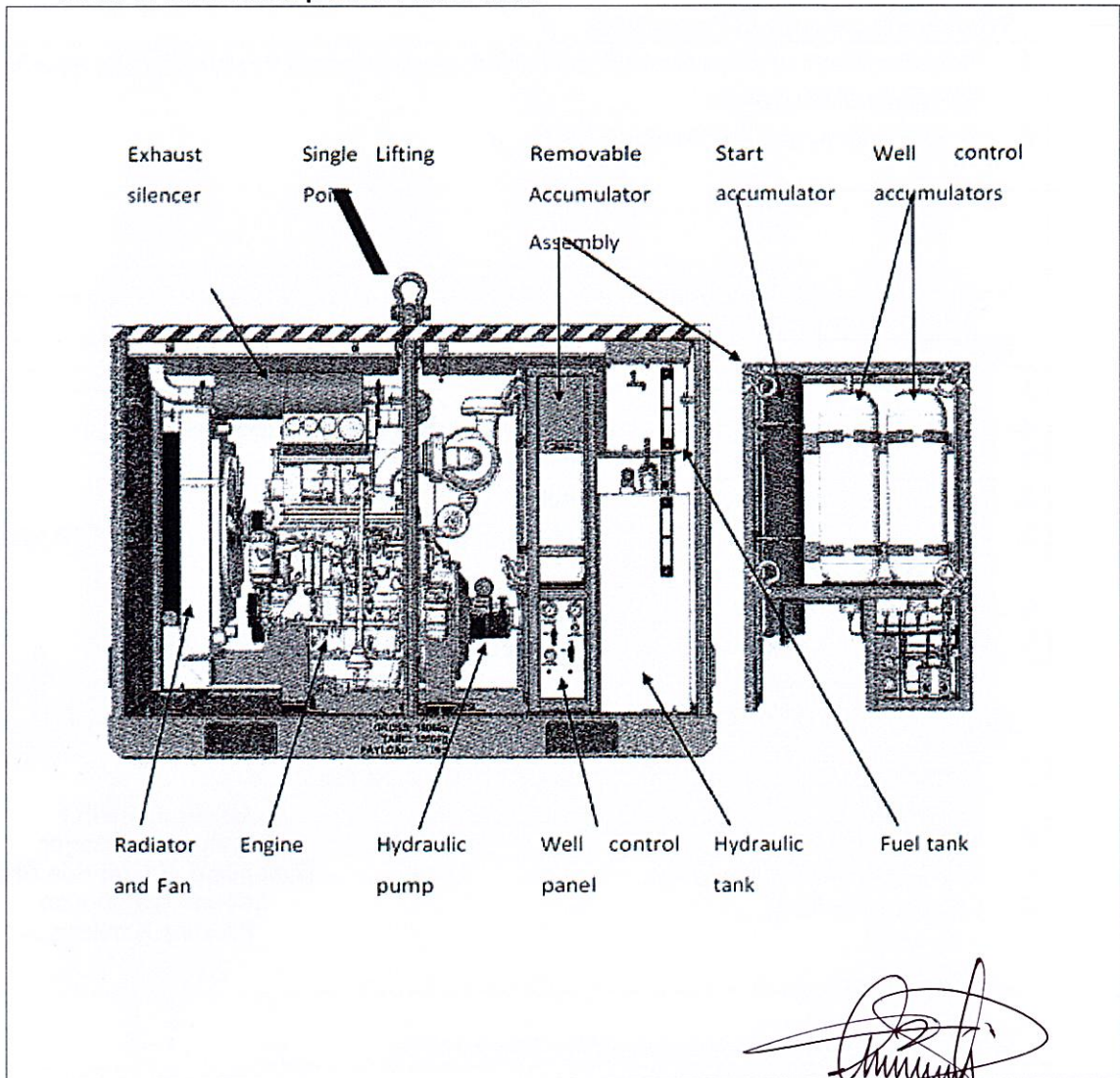

(Signature)
GAZALI MEHRY
 Operation Manager
 Dimension Bid (M) Sdn Bhd
 Labuan Warehouse
 Slicking Services
7/3/25

B.12. AIR COMPRESSOR

What is Air Compressor

Air compressor is a machine that air being compressed driven by diesel engine. ✓

What is the purpose of Air Compressor

To supply compressed air for control panel, test pump and air stater engine. ✓

How to operate Air Compressor

Starting procedure is similar with power pack. The air compressor usually use spring starter. To crank the starter, rotate the shaft clockwise until indicator turn red. Replace spring to start the engine. ✓

What is maintenance required for Air Compressor

1. Change filters ✓
2. Change oil compressor ✓
3. Check fan belting condition ✓

What is safety precaution required for Air Compressor

1. Make sure all hoses connection no leaking ✓
2. Make sure fan is covered ✓



GAZALI MHENRY
Operation Manager
Dimension Bid (M) Sdn Bhd
Labuan Warehouse
Slickline Services
7/3/25



What is potential hazard during handling Air Compressor

- 1. Hose burst ✓
- 2. Pinch point ✓
- 3. Hot surface ✓

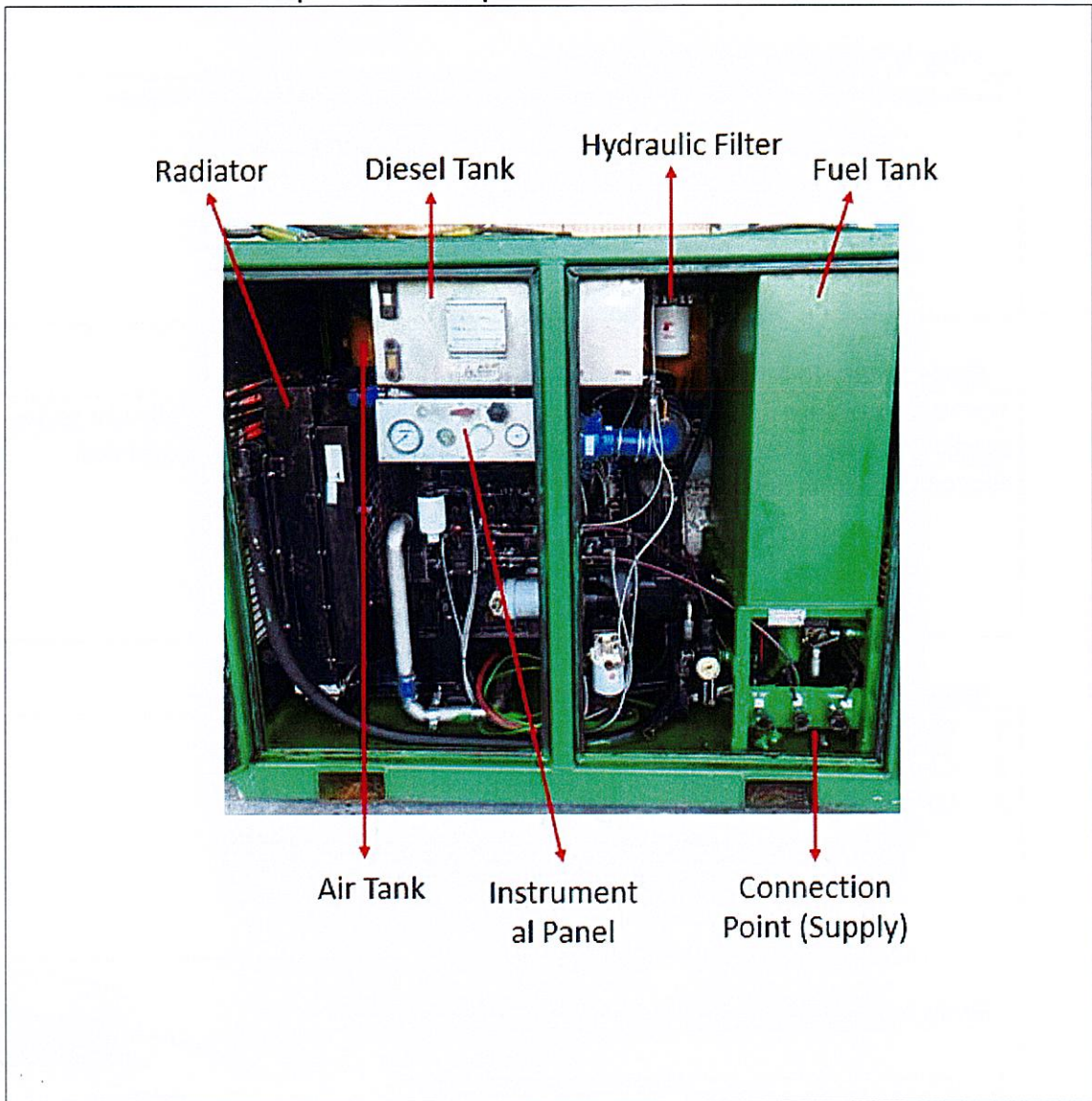
Draw & name each part of Air Compressor



GAZALI MEHRY
Operation Manager
Dimension Bid (M) Sdn Bhd
Labuan Warehouse
Slickline Services

3/3/25



B.13. DRUM

What is the purpose of Drum

The purpose of drum is to spool the wireline wire. ✓

Draw the right and wrong wire arrangement from drum to hay pulley

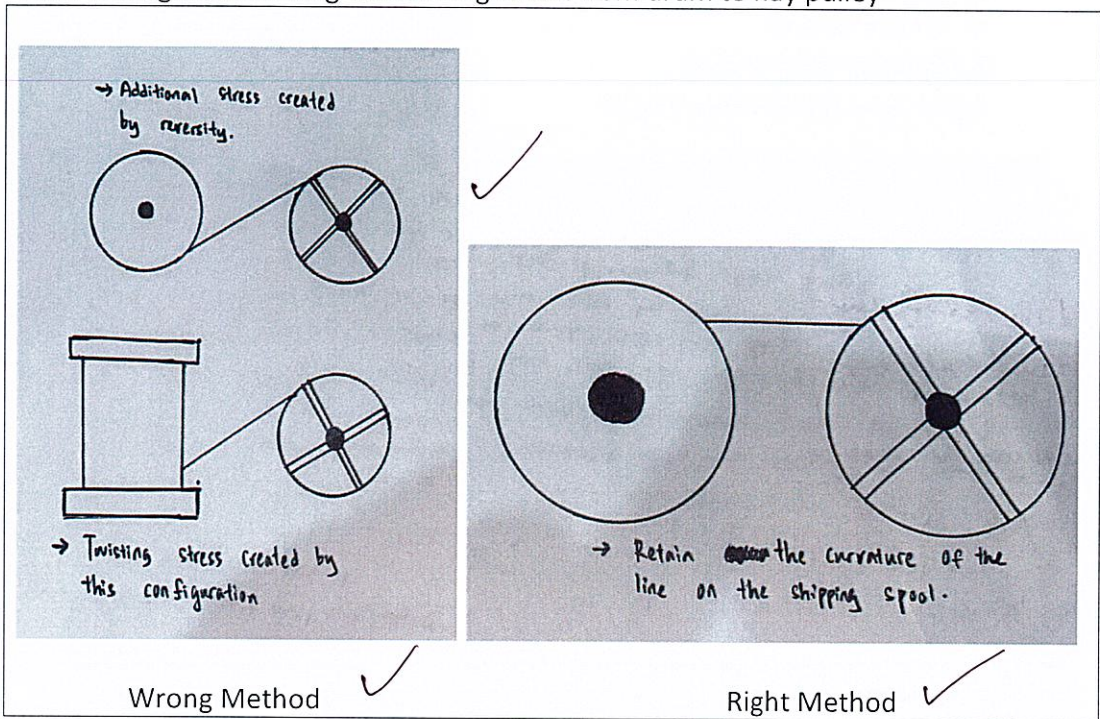

What is maintenance required for Drum

1. Make sure to service and always check the drum bearing, change if there have any broken or damage. ✓

What is safety precaution required for Drum

1. Use tag line or push pull stick ✓
2. Make sure using the safety glasses and appropriate PPE ✓

[Signature]
6
GAZALI MEHRY
Operation Manager
Dimension Bid (M) Sdn Bhd
Labuan Warehouse
Slickline Services
7/3/25



What is potential hazard during handling Drum

- 1) ✓ Rotating device
- 2) ✓ Pinch point
- 3) ✓ Back injury

Please draw/sketch the toolstring configuration for:

- 1) ✓ Drift run/tubing clearance check
- 2) ✓ Sinker bar run
- 3) ✓ Set and retrieve plug
- 4) ✓ Set and retrieve insert valve

GAZALI MEHRY
Operation Manager
Dimension Bid (M) Sdn Bhd
Labuan Warehouse
Slickline Services
7/3/25

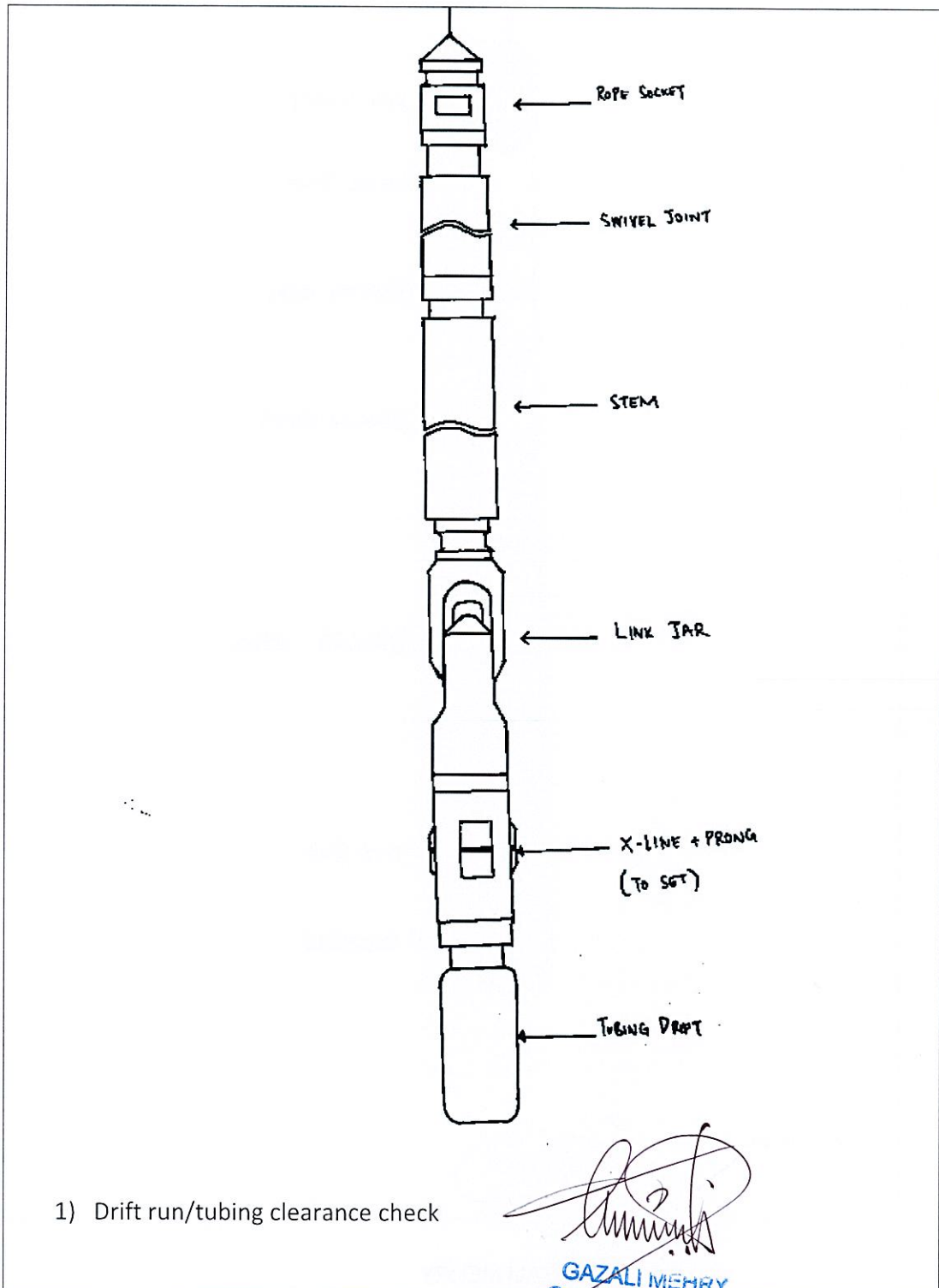

[Signature]
GAZALI MERRY
Operation Manager
Dimension Bid (M) Sdn Bhd
Labuan Warehouse
Slickline Services

7/3/28

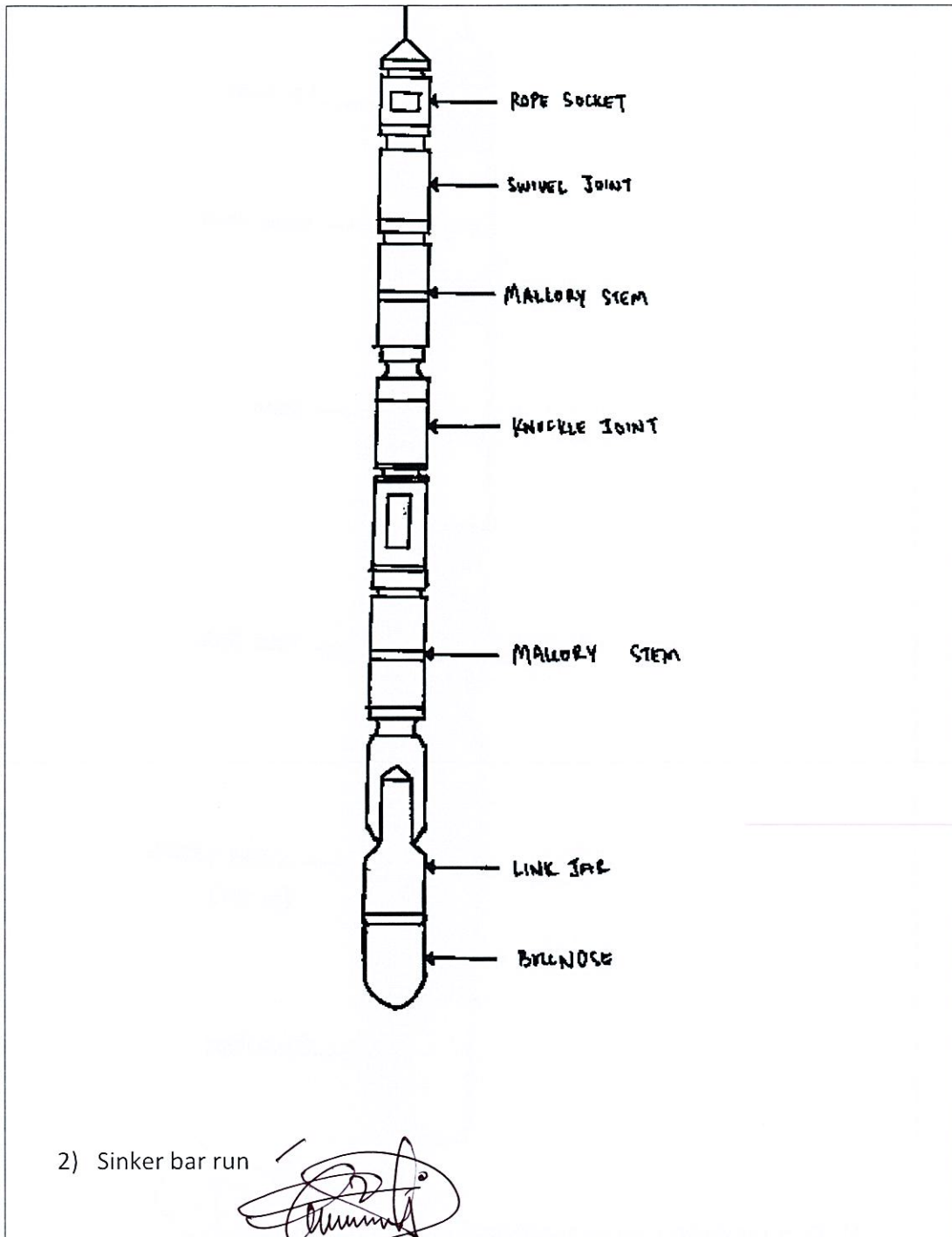

GAZALI MEHRY
Operation Manager
Dimension Bid (M) Sdn Bhd
Labuan Warehouse
Slickline Services

7/3/18

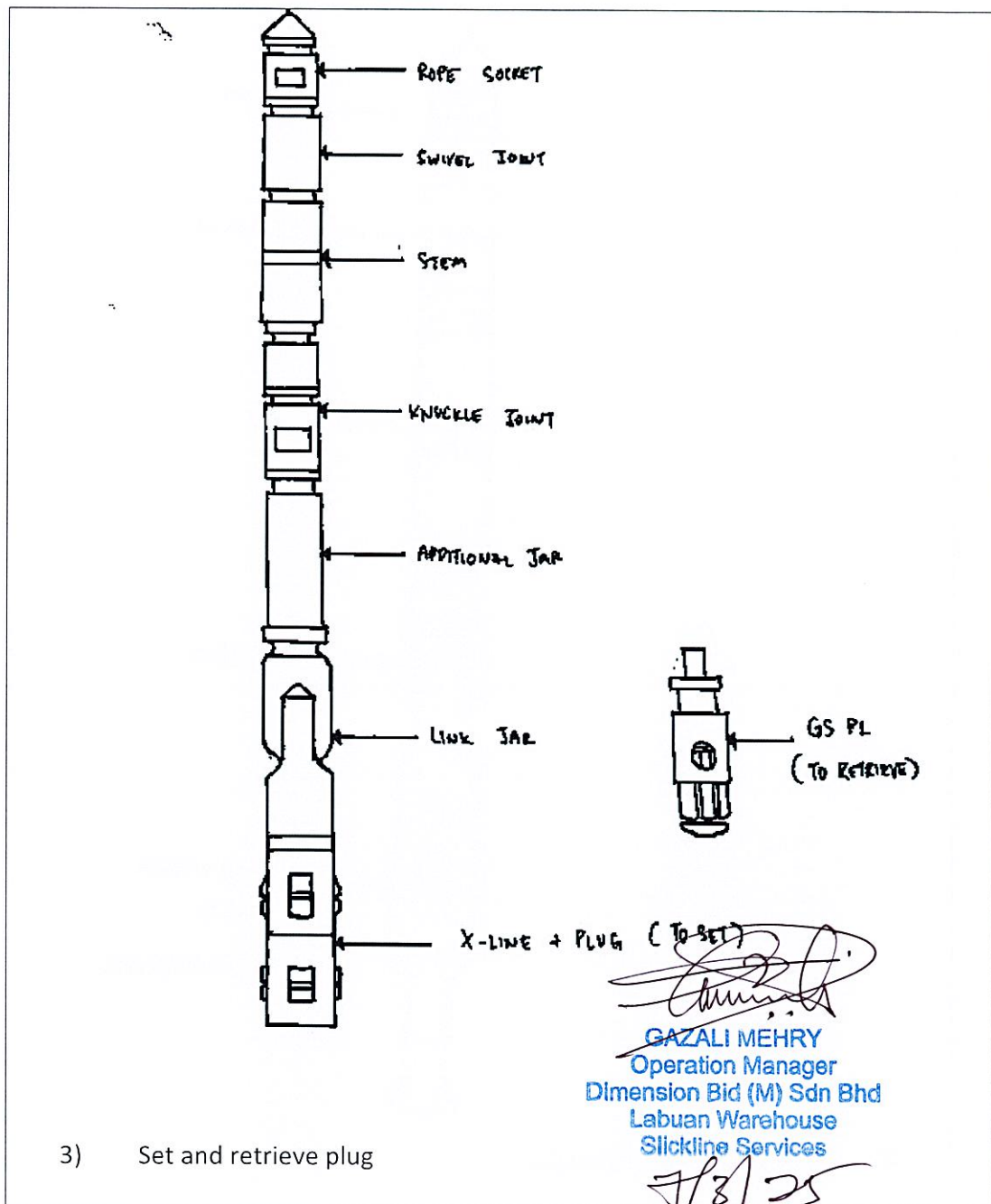

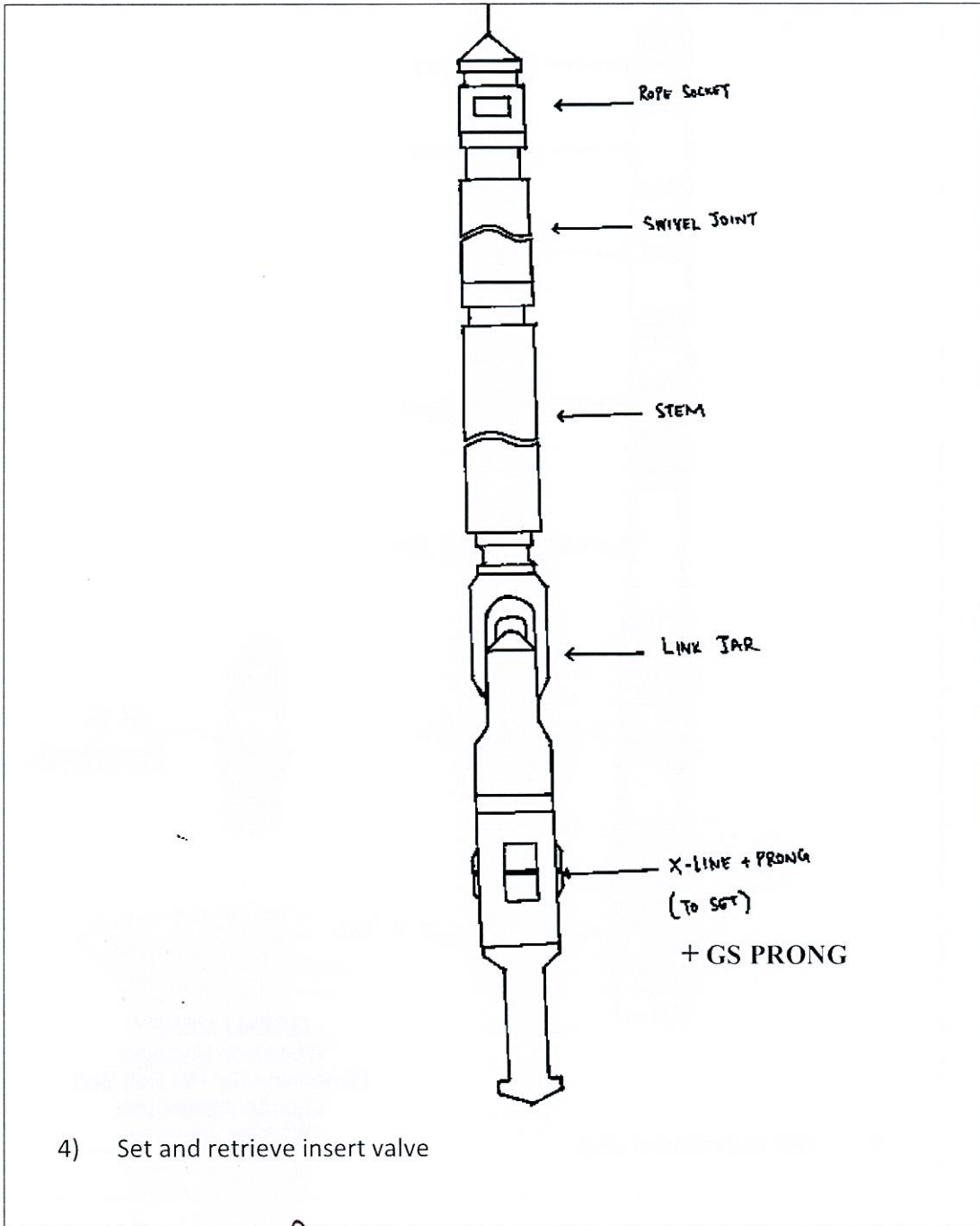

GAZALI MEHRY
Operation Manager
Dimension Bid (M) Sdn Bhd
Labuan Warehouse
Slickline Services

7/3/25