



CTS PRESENTATION ASSESSMENT FORM

Presenter's Name	MUHAMMAD ALIFF BIN ZULKIFLI	Date	3/11/2024
Position	EQUIPMENT OPERATOR 2	SCORE	
Topic	TRIPLEX PUMP		
Objective	PROMOTION		
Assessor (s)	Saifuldin Yaacob		

Assessment Criteria	Rating (Please ✓ where appropriate)								
	STRONG			ADEQUATE			IMPROVEMENT NEEDED		
	10	9	8	7	6	5	4	3	2
A Presentation Skill (20%)									
a. The presenter was well prepared and delivered the material in a clear and structured manner.		✓							
b. The presenter was knowledgeable about the topic and able to relate the importance of the subject matter to his job			✓						
c. The presentation contained practical examples and useful techniques that applied to current work.		✓							
B Creativity (20%)									
a. Did the presenter show creative thinking in the method of development and presentation?			✓						
b. Did presenter get audience involved in "learning" the material?			✓						
C Content (60%)									
a. Did the presenter cover all the key points of the subject matter			✓						
b. Did the presentation incorporate strong, effective supporting material throughout?			✓						
c. Did the presenter give clear and concert explanation and example?			✓						
d. Was the presenter able to answer questions on subject matter? Answers were correct and corresponded with the required understanding?			✓						

Additional Comments:

Good present by presenter - Good knowledges of equipment.

Assessed By:	Verified By:
	
Name: Saifuldin Yaacob	Name: M. KHAIROL RIDHWAN AZIZAN
Position: CSD	Position: CTS FIELD SERVICE MANAGER
Date: 3/11/24	Date: 3/11/24

ATTENDANCE FORM

Purpose: Meeting Training / Seminar / Workshop

Type of Training: Classroom Practical / Hands On Technical Sharing

Training Facilitator / Trainer: MUHAMMAD ACIFF BIN ZOLKEFLI

Topic/Subject	TRIPLEX PUMP	Date	3/11/2024
Venue	MEETING ROOM	Time	2.30 PM
Meeting Coordinator		Meeting/ Training Duration	

No.	Name	Position	Signature
1	ENGRU NAZRI	CEO	
2	ABUL HANAFI	PS	
3	Mohd Hasyam bin Mat	EO	
4	HAFIZ HOSLAN	PS	
5	HAFIZUDDIN	EST	
6	MURAMAD DIMUDIN	EO	
7	AHMAD SHABEER BIN MOHAMAD	EOT	
8	AHMAD SHAFRI BIN MOHAMAD	CEO	
9	SHAFIQ IZHAM B. AWAS	EOT	
10	M. Haikal Rosli	EOT	
12	M. Ikram Hazi bin Salleh	EO	
13	MUHAMMAD AMIR B. MOHD JUANDA	EOT	
14	MUHAMMAD NOOR HANKA	EOT	
15	Muhammad Irfan B. Yusran	EOT	

kur / 2024
Remark / Comment

JRE

d.

Triplex Pump

Prepared by:

Muhammad Aliff bin Zulkefli

Department:

Coiled Tubing Services

Table of Content

01

Function

02

Component

03

Size and Rating

04

Troubleshoot

Objectives

01 Explain the function of a triplex pump

02 Identify the various components of the triplex pump

03 Identify the sizes and ratings on the triplex pump

04 Troubleshoot common pump problems

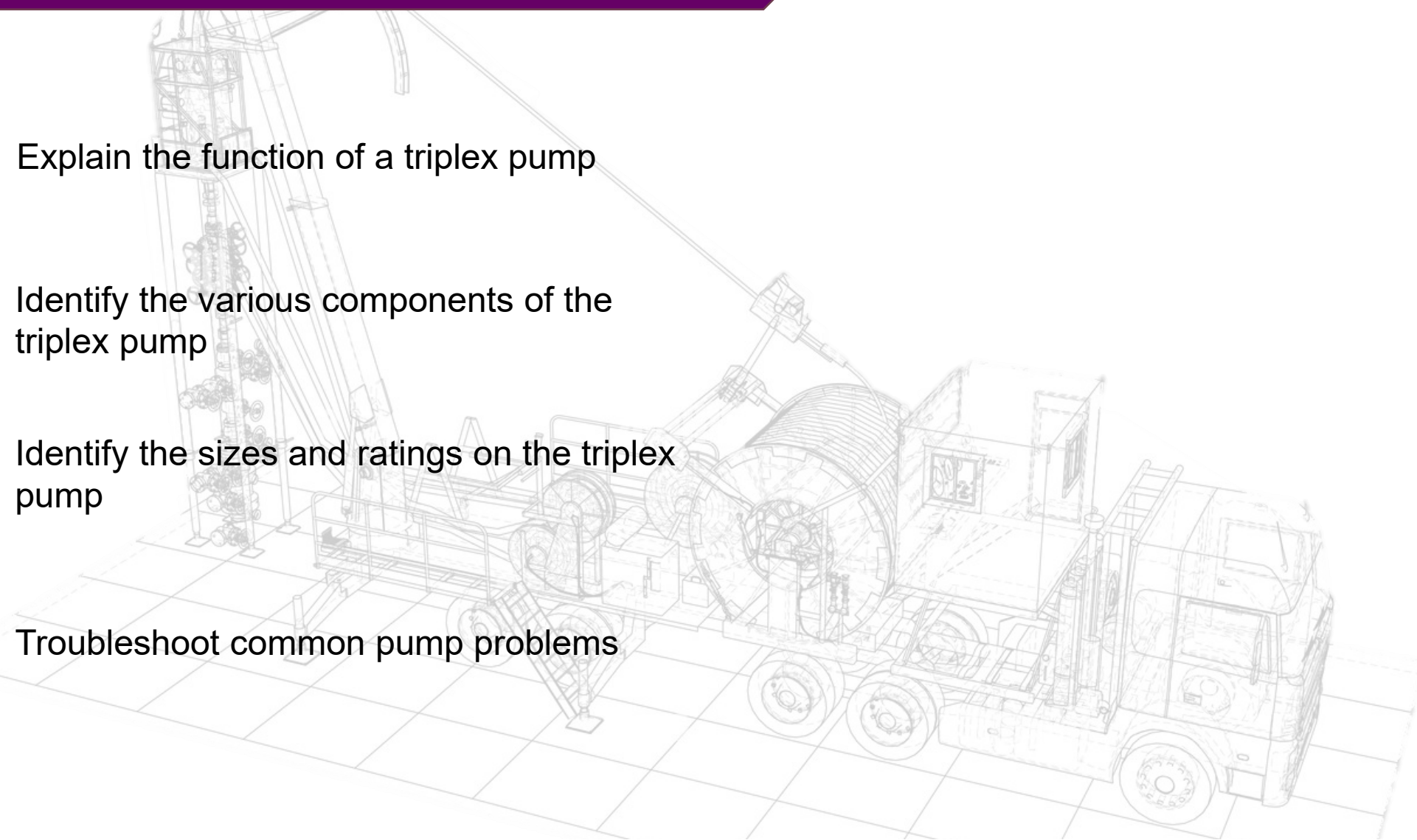

01

Function

Triplex Pump

- The purpose of any pump is to convert mechanical energy provided by motors, and engines, into fluid energy



02

Component

Component of Triplex Pump

➤ **Component:**

- Chain Case
- Power End
- Fluid End



Chain Case

- The chain case, also called a speed reducer: Reduces the input shaft revolutions per minute (rpm).

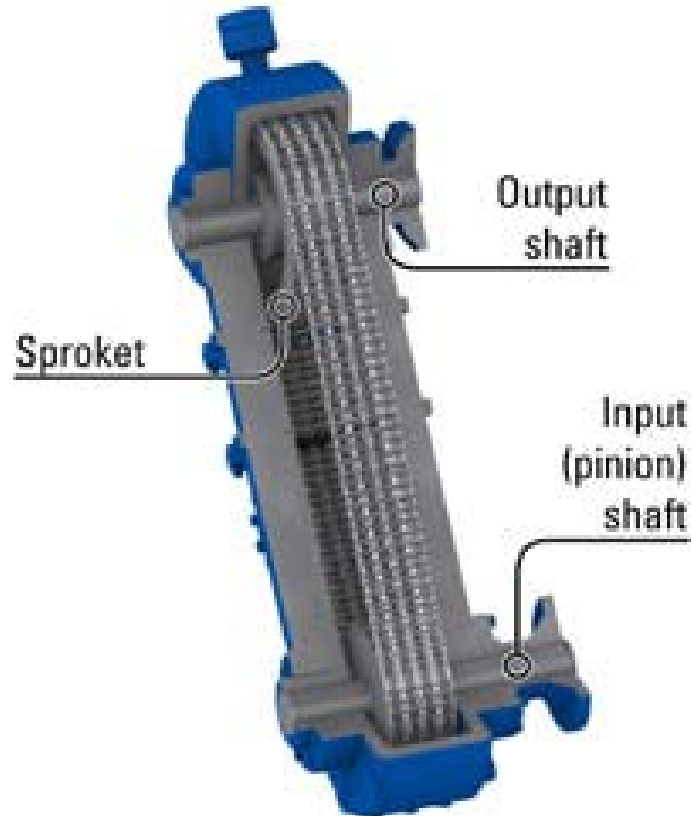

Power End

- Converts rotational power into reciprocating power. The power end functions the same way as a crankshaft in a motorcar engine.

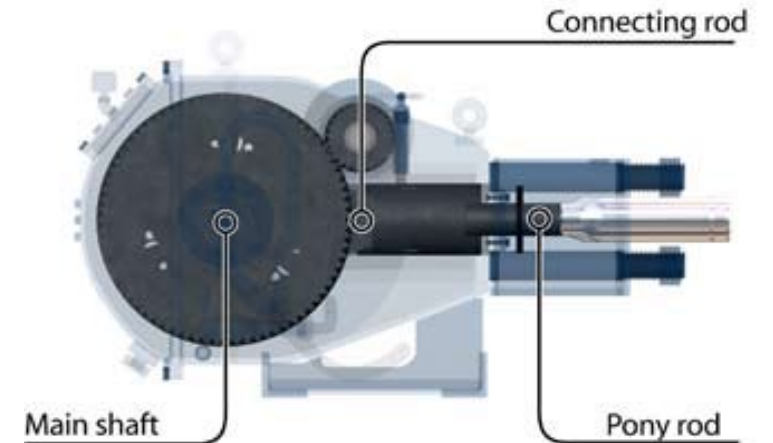
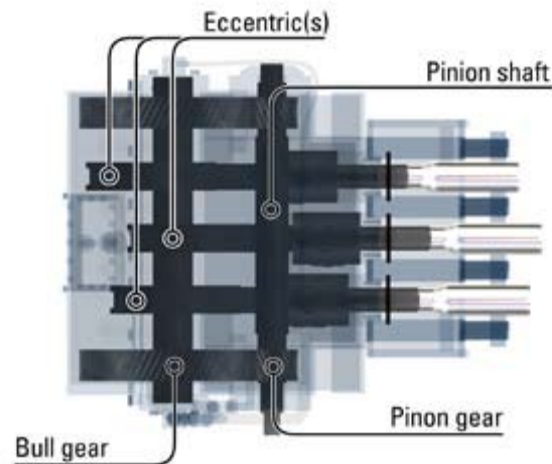

Fluid End

- The fluid end receives the power from the power end. This part of the triplex pump receives fluid at a low pressure, applies horsepower to the fluid, and discharges fluid at a high pressure.
- Type of Fluid End:
 - SPM
 - Gardner Denver

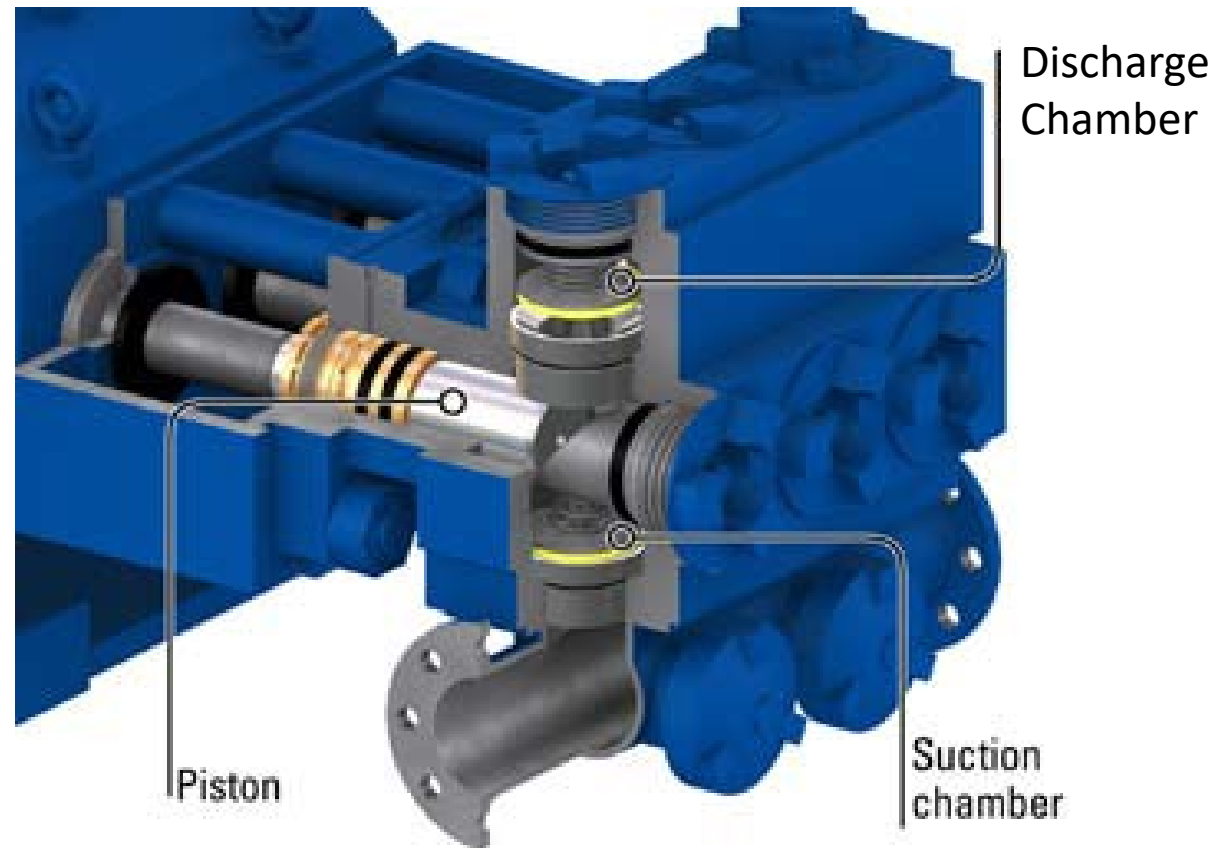

Fluid End - *continue*

Component inside Fluid End:

01

Insert Valve



02

Plunger



03

Packing Plunger

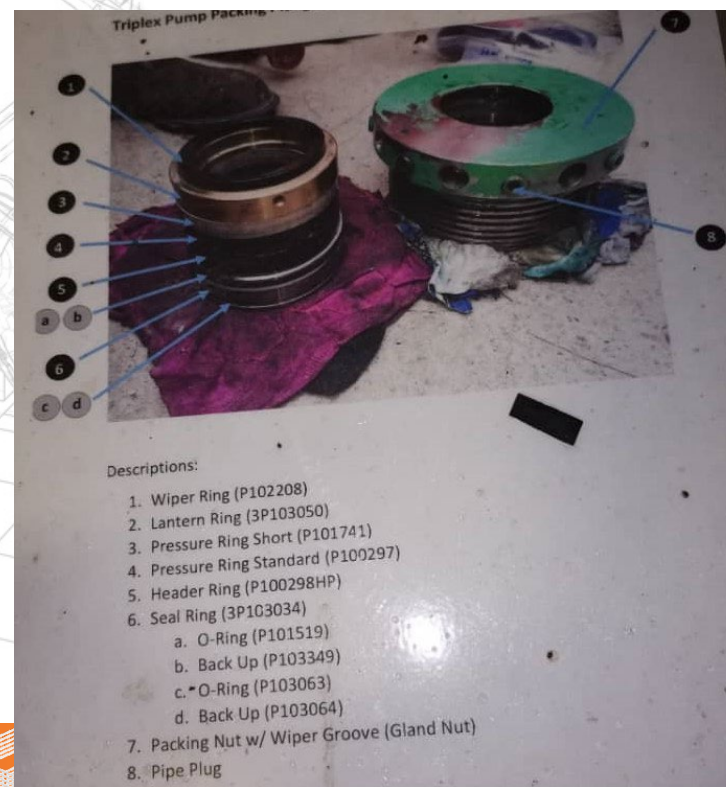

04

Valve Seat

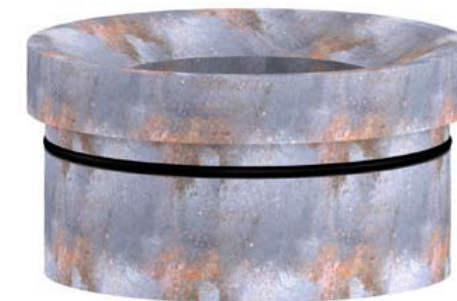

03

Size and Rating

Size and Rating

Pump Unit	Plunger's Size (inch)	Rating Pressure (psi)
SP01	2.75	15,000
SP02	3.50	10,000
SP03	3.00	7,000
SP04	3.50	10,000

04

Troubleshoot

Troubleshoot Power End

Symptom	Cause	Correction
Crosshead seal leaking	Seal has come loose from the holder.	Clean seal holder and install new seal per overhaul manual.
Crosshead seal leaking	Corroded and rough crosshead shank wearing on seal.	Install crosshead sleeve #459569000 per overhaul manual
Knocking around in power end	Loose eccentric because of keyway enlarged by overload.	Replace mainshaft, eccentrics, and connecting rod inserts per overhaul manual
Cement in power end	Leakage or jetting of cement past fluid end packing into the enclosure box and crosshead seal into the power end.	Remove cement. Wash with water. Fill with diesel fuel (Circulate 15 minutes and drain). Repeat with fresh diesel fluid. Replace fluid end packing, crosshead seals, lubrication filter element, connecting rod inserts. Fill with clean oil.

Troubleshoot Fluid End

Symptom	Cause	Correction
Pump is rough running	<ol style="list-style-type: none"> 1. Worn valve and insert 2. Worn valve seat 3. Broken valve spring 4. Pumping fluid cavitation 5. Object under valve 	<ol style="list-style-type: none"> 1. Replace valve. 2. Check the seat gauge or replace seat. 3. Replace springs. 4. Pump rate too fast or suction line plugged. 5. Remove object.
Packing life is short	<ol style="list-style-type: none"> 1. Clogged lubricator line 2. Dull or worn finish on plunger 3. Improper installation 4. Worn packing bore 	<ol style="list-style-type: none"> 1. Service and clean divider block and check valve. 2. Replace plungers. 3. See packing manual. 4. Replace fluid end if worn grooves more that 1/64-in deep.
Packing is smoking	<ol style="list-style-type: none"> 1. No oil 2. Clogged lubricator line 	<ol style="list-style-type: none"> 1. Check lubricator reservoir. 2. Clean divider block and check valve.
Packing life is short	<ol style="list-style-type: none"> 3. Packing nut too tight 	<ol style="list-style-type: none"> 3. Loosen nut slightly.
Packing is leaking	<ol style="list-style-type: none"> 1. Worn out or too loose 2. Worn plunger 	<ol style="list-style-type: none"> 1. Tighten or replace packing. 2. Replace plunger.
Priming is difficult	<ol style="list-style-type: none"> 1. Choked valve 2. Broken valve spring 	<ol style="list-style-type: none"> 1. Inspect and straighten valve. 2. Replace spring.
Leakage at discharge outlet	<ol style="list-style-type: none"> 1. Worn seal or bushing 2. Washed out discharge bore 	<ol style="list-style-type: none"> 1. Replace seal (O-ring). 2. Replace fluid end.