

SLICKLINE OPERATOR WORKBOOK

IMPORTANT NOTE:

1. Your point of reference to complete this workbook may be obtained from the following
 - Training Manual and any other training materials provided together with this workbook
 - Your Trainer, Assessor (Slickline Operator), Verifier (FSM) or senior colleagues
 - SOP / Quality Procedures & Processors
2. The completion of this Workbook is a joint effort and responsibility between you and your assessor therefore you have the obligation to request from your assessor to be assessed upon your completion of each topic
3. The completion of this Workbook is part of the MANDATORY requirements which you must fulfill to qualify for a promotion
4. Your training program is mostly self-driven, including this Workbook. It requires individual initiatives, dedication and commitment to complete the process.

NAME	ELDRIAN BIN JUIL
DATE OF JOIN	2ND AUGUST 2021
CONTACT NO.	0138536077
RECEIVED DATE	6TH MARCH 2023
DATE COMPLETED	16th July 2024

C. MAINTENANCE

Legend: C-Competent, NME-Need More Exposure

Document No.	KNOWLEDGE ON EQUIPMENT AND SKILLS IN MAINTENANCE AND TROUBLESHOOTING	Assessment / Verification	Competency		Assessment Date
			C	NME	
Form C.1	EQUIPMENT DETAILED SPECIFICATION				
	1 Explain what is equipment specification of wireline tool example 3.0" GS pulling tool <ul style="list-style-type: none"> Equipment specification is a full description of the tool describing the size, dimension, part number and material composition. BDMI - Basic Design and Maintenance Instruction of tool is a full description of disassembling step by step procedure of disassembling and assembling every component of the tool and replaced for any faulty parts. Upon completion the tool has to be function tested, preserved with antirust and stored up ready for use. 				
	2 How do you place an order for wireline tools? What are the requirements to look for? <ul style="list-style-type: none"> The Things required when ordering w/line tool are description mentioning size, thread connection and type, reference number and part number Send email or fax a copy of your request to w/shop supervisor attention EPA-T-WSV Amok Dagat and file in your office for future reference and follow up. 				
3 If given a basic drawing of wireline tools are you able to service the tool? <ul style="list-style-type: none"> Yes 					

	<p>4 When you received a new equipment or wireline tool what are things you should do and what to look for.</p> <ul style="list-style-type: none"> • <u>Note down the serial number</u> • <u>Check the dimension as per the request</u> • <u>Check for certification from manufacture</u> • <u>Check the due date of equipment and wire sling.</u> • <u>Check the condition of tool if not good or damage make report and highlight to relevant parties (w/shop, supervisor on site)</u> 				
	<p>5 Where do you look for specification of pressurized vessel or container? What is written there?</p> <ul style="list-style-type: none"> • <u>The specification of pressurized is normally attached to the body of the vessel or container label in a stainless-steel plate or proof sticker with clear written letters.</u> • <u>The vessel specification indicating volume, size and working test pressure, last test date.</u> 				
Form C.2	EQUIPMENT OPERATION PROCEDURES				
	<p>1. What is an equipment operating procedure?</p> <ul style="list-style-type: none"> • <u>An equipment operating procedure is a document method of how it is operated recommended by the manufacturer</u> • <u>In the manual using their specification, general features and maintenance schedule of 3 month, 6 month, 1 year and 3 years are highlighted and to be adhered to and practiced.</u> 				
	<p>2. Does all the equipment have an operating procedure and what is it for?</p> <ul style="list-style-type: none"> • <u>Yes. It gives the guideline of how the equipment will be operated and maintained in order to prolong its life span. Not only but also provide info and trouble shooting in case of problem.</u> 				

	<p>3. Explain what will be the consequences if you are not following the operating procedures.</p> <ul style="list-style-type: none"> • <u>The consequences will be loss of property, income and reputation, as a result the company will loss it's trust and income from the client as well as down time. This is considered a serious matter which be reported as non-compliance.</u> 				
	<p>4. Does Dimension Bid have operating procedures and where are they kept?</p> <ul style="list-style-type: none"> • <u>Yes. It gives the guideline of how the equipment will be operated and maintained in order to prolong its life span. Not only but also provide info and trouble shooting in case of problem.</u> 				
	<p>5. Explain how the Reel Skid Unit Operating</p> <ul style="list-style-type: none"> • <u>REEL SKIT UNIT-Brake must be applied, gear on neutral, back off 4 ways directional valve screw and hydraulic hoses must be secured and PTW be approved by relevant parties and equipment passport still valid.</u> • <u>All lifting color coding and sling is valid.</u> 				
	<p>6. Explain how the following Power Pack operating:</p> <p>i. Diesel Power Pack</p> <ul style="list-style-type: none"> • <u>WIRELINE POWER PACK-Check for diesel,engine oil, radiator water coolant and level, hydraulic oil refill if necessary, Equipment passport and tag a valid. All hydraulic hose properly secured and whip check still intact. Spark arrestor and shutdown system is functioning and lifting pad eye is valid and good condition.</u> <p>ii. Electrical Power Pack</p> <ul style="list-style-type: none"> • <u>Electrical power packs are very simple to operate. However, care must be taken to ensure that the power pack is connected to the correct power source. When the power pack has been connected, the direction in which the motor is running must be checked.</u> 				

	<p>7. Explain how to start the Diesel Power Pack and show how to hook-up 1" and 1 – ¼" Hydraulic Hose</p> <ul style="list-style-type: none"> • <u>Before starting, the hydraulic system must be looped or connected to the wireline unit. Check hydraulic tank suction line ball valve is fully open.</u> • <u>Check hydraulic oil level in hydraulic tank is up to minimum level if less top-up.</u> • <u>Check diesel level in diesel tank if less top-up.</u> • <u>Check engine oil level.</u> • <u>Check Air inlet /outlet and exhaust are not blocked. -Check engine fan belt and guards.</u> • <u>Check exhaust Flame trap is fitted in exhaust heat exchanger after cleaning. Engine cranking is done with the help of hydraulic starter.</u> • <u>Check accumulator pressure should be greater than 2500 Psi.</u> • <u>Check all hydraulic quick connectors for winch and BOP is connected properly.</u> • <u>Check radiator coolant level.</u> 				
	<p>8. Explain how to start the Air Compressor</p> <ul style="list-style-type: none"> • <u>Keep engine cable fully in which is mounted on the control panel.</u> • <u>Keep the diesel cut off valve in start position.</u> • <u>Recoil spring starter by tuning on clockwise direction.</u> • <u>Start engine by pulling and holding inlet over speed shut down valve and releasing the spring starter start lever.</u> • <u>Keep and continue holding the inlet over shut down valve (Approx. 10 min) until oil pressure is built.</u> 				

	<p>9. Identify the Portable Control Panel and explain its function</p> <ul style="list-style-type: none"> • <u>Air supply gauge</u> • <u>Bleed and relief valve</u> • <u>Regulator</u> • <u>MV valve</u> • <u>MV gauge</u> • <u>Crossover valve</u> • <u>SCSSV valve</u> • <u>SCSSV gauge</u> • <u>Hydraulic tank</u> 				
	<p>10. Explain how to operate Control Panel – TRSCSSV, SDV, BOP, Accumulator Tank and Stuffing Box.</p> <ul style="list-style-type: none"> • <u>Hook up the SCSSV output line from the single well control unit to the bleed-off valve on the control line manifold at the wellhead using 1 / 4 " control line.</u> • <u>Pressure tests this line to 5000 psig to check integrity of all connections. If no leaks observed, bleed down the pressure to 4000 psig.</u> • <u>Hook up the SSV output line from the single well control unit to the bleed-off valve on the supply line to the upper master valve actuator using 1 / 4 " control line.</u> • <u>Pressure test this line to 3000 psig to check integrity of all connections. If no leaks observed, bleed down the pressure to 2500 psig.</u> • <u>Close the needle valve at the wellhead control line manifold on the supply line from the platform's central well control panel and open the bleed-off valve on the control line manifold at the wellhead. This will enable the well services single well control unit to take over control of the SCSSV.</u> • <u>Close the needle valve at the upper master valve hydraulic actuator supply line from the platform's central well control panel and open the bleed-off valve on the supply line. This will enable the well services single well control unit to take over control of the SSV.</u> 				
	<p>11. Show how to hook – up ¼" Hydraulic Hose to the following system</p> <ol style="list-style-type: none"> i. Pressure Manifold /TRSCSSV ii. Stuffing Box iii. BOP 				

	12. Explain how to operate Test Pump <ul style="list-style-type: none"> • <u>Check condition of pressure test pump</u> • <u>Visually check all hoses, tubing fittings etc. for any signs of damage.</u> • <u>Check water tank and ensure fill with fresh water.</u> • <u>Air regulator is off (regulators fully anti clockwise).</u> • <u>Needle valve to recorder chart and lubricator are open position.</u> • <u>With air regulators to set 300psi for low pressure.</u> • <u>increase air regulator 10100 for 10% close in pressure.</u> • <u>Adjust the air regulator to maintain this pressure if required.</u> • <u>Close needle valve at lubricator.</u> • <u>After pressure test ok, release the pressure, open the control line dump valve.</u> 				
	13. Identify the Air Receiver Tank and explain its function <ul style="list-style-type: none"> • <u>The tank is a reservoir of compress air that can be used during peak demand.</u> 				
	14. Explain how to operate Air Receiver Tank <ul style="list-style-type: none"> • <u>Start the engine.</u> • <u>Pull the knob to charging the receiver tank.</u> • <u>Charging until the tank full.</u> • <u>Open the outlet valve to use the pressure tank.</u> 				
	15. What is the Working Pressure for Air Receiver Tank <ul style="list-style-type: none"> • <u>1000 psi</u> 				
	16. Identify the Spooling Unit and explain its function <ul style="list-style-type: none"> • <u>To spool new wire and change the wire size.</u> 				

	<p>17. Show where the following components allocated at Spooling Unit and explain the function</p> <ul style="list-style-type: none"> i. Pressure Control Valve. <u>To reduce and increase drum speed during spooling wire.</u> ii. Braking System <u>To stop the drum during spooling wire.</u> 				
	<p>18. Participate in spooling wire activity at least 3 times. Explain what are the other equipment required besides Spooling to perform spooling activity.</p> <ul style="list-style-type: none"> • <u>Power Pack</u> • <u>RSU</u> • <u>Hey Pulley</u> 				
	<p>19. What do “SPOOL-IN” and “SPOOL-OUT” wire mean? When do these activities take place?</p> <ul style="list-style-type: none"> • <u>During wireline operation spool in means pull out of hole (POOH).</u> • <u>Spool out means RUN in hole (RIH) the activities take place if we doing the wireline operation etc. GLVC, SET PLUG, SGS, FGS.WAX CUT.</u> 				
	<p>20. Why is it compulsory to secure Spooling Unit with Tie Down Chain During spool-in / our wire activity?</p> <ul style="list-style-type: none"> • <u>To prevent spooling unit falling into position.</u> 				
	<p>21. Explain how the Stuffing Box operating</p> <ul style="list-style-type: none"> • <u>The function of the Wireline Stuffing Box is to ensure containment or sealing off around solid wireline, weather stationary or in motion, at the upper end of the Lubricator during wireline operations. In addition, most Stuffing Boxes contain a BOP plunger, which is forced out of the packing section to seal off flow in the event of wireline breakage.</u> 				



22. Show how to connect the Stuffing Box with lubricator and where to hook-up the Stuffing Box hydraulic hose

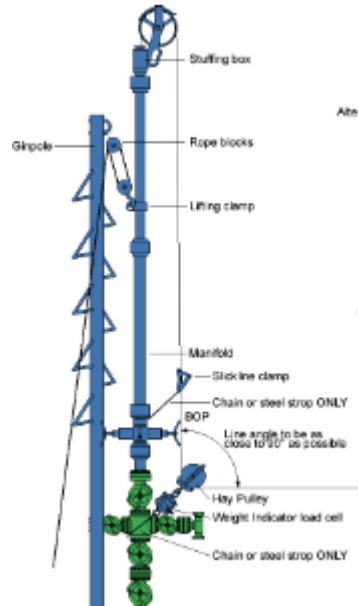

23. Identify the BOP and explain its function

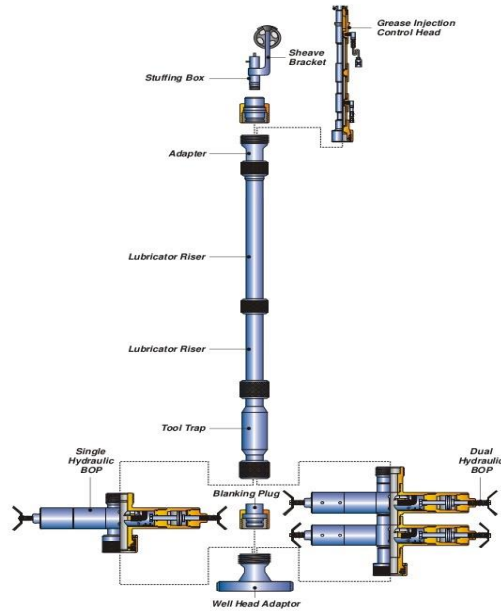

- To prevent a blow out during wireline operation in the event of an emergency breakdown in lubricator configuration
- To act as a secondary valve in case a safety valve is stuck across the swab valve and master valve
- To seal off pressure around a wire that is across the BOP and also allowing the wire is not cut off
- To enable the well pressure to be isolated without cutting the wire by closing the master valve.
- To permit the assembly of the wireline cutter above the BOP rams.
- To permit the dropping of a wireline cutter if the toolstring becomes stack in the well.
- To permit stripping of the wire through closed rams. Only when necessary.

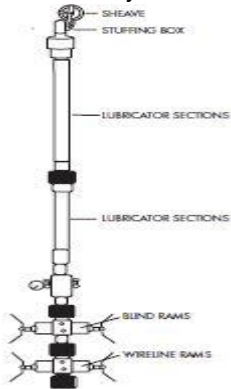
	<p>24. Identify the BOP hydraulic hose required and hook-up to the Control Panel. Explain how to Close and Open BOP Upper & Lower Ram</p>				
	<p>25. Show how to connect the BOP with lubricator and where the position of BOP during wireline job</p>  <ul style="list-style-type: none"> • <u>The grease seal pressure is adjustable for varying well pressure.</u> • <u>The lubricator is an intrinsic part of the primary well control system along with the grease seal.</u> • <u>If the grease seal fails, both the wireline BOP wire rams can be closed on the wire. The lower ram is inverted so that grease can be injected to create seal.</u> • <u>If the wire is broken and expelled from the lubricator, two Xmas tree must be closed to provide double isolation.</u> • <u>If the rams leak, the wire can only be cut with a wire cutting actuator.</u> 				
	<p>26. What is the different between Lubricator, Riser and Pump Joint?</p> <ul style="list-style-type: none"> • <u>Different length</u> 				

	<p>27. Make-up 3 sections of lubricator and perform pressure test max 2000 psi ing Unit to perform spooling activity</p> 				
	<p>28. What is the common length for Dimension Bid Lubricator? Besides the common length, what is the other length appear in Dimension Bid?</p> <ul style="list-style-type: none"> • <u>4 section lubricator x 8ft</u> • <u>Pup joint 2 ft, 3 ft, 4ft</u> • <u>Cross over</u> 				

29. Identify the following threaded size

- i. 5 – 5/8” WKM Hammer Union to suit 3-1/8” WKM Single X-mass Tree

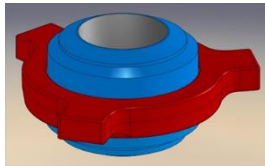

- ii. 5 – 5/8” WKM Hammer Union to suit 2-9/16” WKM Single X-mass Tree

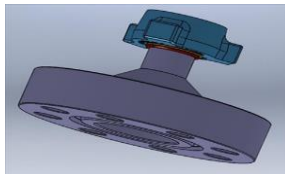





- iii. 5 – 1/5” WKM Quick Union to suit 3-1/8” WKM Single X-mass Tree

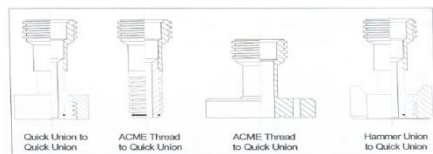

- iv. 3 – 1/2 ” EUE Pin



<p>v. 8.25" – 4 ACME Type 'O'</p>  				
<p>30. What is the common length of Wellhead X-over in Dimension Bid? Why?</p> <ul style="list-style-type: none"> • <u>2ft to accommodate the length of short string in dual completion.</u> 				
<p>31. Show how to rig-up Wellhead X-over and explain step by step</p> <ul style="list-style-type: none"> • <u>Close Actuator</u> • <u>Close swab valve.</u> • <u>Bleed of pressure trap</u> • <u>Open tree cap (ensure pressure zero before open tree cap)</u> • <u>Check o ring</u> • <u>install the well head x-over onto well head.</u> 				
<p>32. What is the ID for: 3- ½", 4- ½ "and 5- ½ "nominal lubricator</p> <ul style="list-style-type: none"> • <u>3- ½ - 2.992"</u> • <u>4- ½ - 3.826"</u> • <u>5- ½ - 4.893"</u> 				
<p>33. Identify the Pump-in Tee and TIW Valve and explain its function</p> <ul style="list-style-type: none"> • <u>Pump in tee may be required as part of a wireline rig up. By connection a kill line to the chickson / weco connection, the well can be killed in an emergency situation. This is can be used to pressure test or release pressure from the surface equipment.</u> • <u>TIW valve designed for hold the pressure from the above or below, second barrier during wireline operation.</u> 				

	<ul style="list-style-type: none"> • Identify the following threaded size and ball valve • 1502 Thread Half Union Side Outlet (For Chicksan Line)   <ul style="list-style-type: none"> • 3" Ball Valve  <ul style="list-style-type: none"> • 5-4 acme otis 				
	<p>34. Where is the pump-in Tee and TIW Valve should be rigged-up during wireline job?</p> <ol style="list-style-type: none"> Pump-in Tee <ul style="list-style-type: none"> • Pump in tee installed below the BOP TIW Valve <ul style="list-style-type: none"> • Installed at top x'mas tree 				



	<p>35. Explain step by step how to rig-up Pump-in Tee and TIW Valve</p> <ul style="list-style-type: none">• <u>Xmas tree, TIW valve, Riser, Pump in Tee, BOP, Quick test sub, Lubricator, Stuffing Box.</u>				
--	---------------------------------------------------------------------------------------------------------------------------------------------------------------------------------------------------------------------------	--	--	--	--

	<p>36. Identify the following wireline tools and explain the function</p> <ul style="list-style-type: none"> i. Tie knot Rope Socket <ul style="list-style-type: none"> • The Rope Socket is required to make the connection between the wireline and tool string. ii. Tear Drop Rope Socket <ul style="list-style-type: none"> • <u>The 'No-Knot' Type Rope Socket (also called a 'teardrop' or 'wedge' type) is designed for 0.108" and 0.125" slickline. While it can be also used for 0.092". The knot type is more common for the thinner wire.</u> iii. Swivel Joint <ul style="list-style-type: none"> • <u>To permit the easy rotation of the toolstring, even under load tools move in/out of the well</u> iv. Wireline Stem <ul style="list-style-type: none"> • <u>The stem is used primarily for running pressure and temperature survey tools to obtain maximum weight with minimum cross-sectional area to prevent the tools "floating" or being blown up the hole by pressure surges.</u> v. Tungsten / Malory Stem <ul style="list-style-type: none"> • <u>To Provide greater weight for the same diameter and length.</u> vi. Roller Stem <ul style="list-style-type: none"> • <u>Addition to toolstring for deviated wells to reduce the frictional losses against the tubing wall.</u> vii. Tungsten Roller Stem <ul style="list-style-type: none"> • <u>To provide greater weight for the same diameter and length.</u> viii. Multi wheel Roller Stem <ul style="list-style-type: none"> • <u>Is used for work on deviated wells, or in wells with the paraffin, asphaltine etc. on the tubing internal walls. It allows the stem to roll down the tubing wall and hence.</u> 				
--	------------------------------------------------------------------------------------------------------------------------------------------------------------------------------------------------------------------------------------------------------------------------------------------------------------------------------------------------------------------------------------------------------------------------------------------------------------------------------------------------------------------------------------------------------------------------------------------------------------------------------------------------------------------------------------------------------------------------------------------------------------------------------------------------------------------------------------------------------------------------------------------------------------------------------------------------------------------------------------------------------------------------------------------------------------------------------------------------------------------------------------------------------------------------------------------------------------------------------------------------------------------------------------------------------------------------------------------------------------------------------------------------------------------------------------------------------------------------------------------------------------------------------------------------------------------------------------------------------------------------------------------------------------------------------------------------------------------------------------------------------------------------------------------------------------------------------------------------------------------------------------------------------------------------	--	--	--	--

	<ul style="list-style-type: none"> ix. Roller Boggie <ul style="list-style-type: none"> • <u>The roller stem is a valuable , sometimes essential , addition to toolstring for deviated wells to reduce the frictional losses against the tubing wall.</u> x. Mechanical Spang Jar <ul style="list-style-type: none"> • <u>It is essential that the operator can recognize the precise opening and closing point of the jars on the martin decker weight indicator.</u> xi. Tubular Jar <ul style="list-style-type: none"> • <u>A tubular jar is preference than a mechanical jar in fishing operation because the tubular jar is an enclose jar and has less chance of wire becoming entangled and jamming the jar</u> xii. Upstroke Spring Jar <ul style="list-style-type: none"> • <u>Up stroke jars a reused for jarring up during wireline pulling operations.</u> xiii. Hydraulic Jar <ul style="list-style-type: none"> • <u>Hydraulic Jars are placed between the stem and mechanical jars in the toolstring, when extra jar up action is required or a need anticipated. This is especially important when conventional jar up action is difficult because of deviation or high viscosity well fluid.</u> xiv. Knuckle Joint <ul style="list-style-type: none"> • <u>Knuckle Joints are used to add flexibility to the tool string and should be used in deviated wells.</u> xv. Quick Connect <ul style="list-style-type: none"> • <u>A faster method connecting tool string components is available using the Quick Lock Connection.</u> xvi. Lead Impression Block <ul style="list-style-type: none"> • <u>Lead Impression Blocks are used to obtain an image profile of a wide range of equipment down hole to be latched or fished, e.g. Rope Socket (with or without wire)</u> 				
--	------------------------------------------------------------------------------------------------------------------------------------------------------------------------------------------------------------------------------------------------------------------------------------------------------------------------------------------------------------------------------------------------------------------------------------------------------------------------------------------------------------------------------------------------------------------------------------------------------------------------------------------------------------------------------------------------------------------------------------------------------------------------------------------------------------------------------------------------------------------------------------------------------------------------------------------------------------------------------------------------------------------------------------------------------------------------------------------------------------------------------------------------------------------------------------------------------------------------------------------------------------------------------------------------------------------------------------------------------------------------------------------------------------------------------------------------------------------------------------------------------------------------------------------------------------------------------------------------------------------------------------------------------------------------------------------------------------------------------------------------------------------------------------------------------------------------------------------------------------------------------------------------------------------------------------------------------------------------------------------------------------------------------------------------------	--	--	--	--

	<p>xvii. Wire Scratcher</p> <ul style="list-style-type: none"> • <u>They are used to dislodge scale, salt, paraffin, etc. from tubing ID or nipple ID etc. Wire Scratcher can also be used to fish small pieces of wireline lying loose in a well or used to locate nipples, Side Pocket Mandrels, etc.</u> <p>xviii. GS Running & Pulling Tool</p> <ul style="list-style-type: none"> • <u>The OTIS GS is a jar down to shear pulling tool to latch internal fishing necks, such as on a Otis 'X' and XN locks</u> <p>xix. OTIS X-Line Running Tool</p> <ul style="list-style-type: none"> • <u>To Set all plug with lock mandrel</u> <p>xx. OTIS SB & RS Pulling Tool</p> <ul style="list-style-type: none"> • <u>SB use to set prong for PXX & PXN plug and jar down to shear</u> • <u>RS use during run tandem jar up to shear</u> <p>xxi. CAMCO JDC & JUS pulling Tool</p> <ul style="list-style-type: none"> • <u>To pull out gas lift at SPM</u> <p>xxii. 1 – ¼” PCE Heavy Duty Pulling Tool</p> <ul style="list-style-type: none"> • <u>To pull out gas valve at SPM</u> <p>xxiii. CAMCO OK – 6 KOT</p> <ul style="list-style-type: none"> • <u>Running tool to pull out and set gas lift.</u> <p>xxiv. OTIS 142 BO & 42 BO Shifting Tool</p> <ul style="list-style-type: none"> • <u>142-BO – to open SSD</u> • <u>42-BO – to confirm SSD fully closed.</u> <p>xxv. Flow petrol Cutter & Drop Bar</p> <ul style="list-style-type: none"> • <u>To cut the wire in well if the DHT become stuck</u> • <u>To Hammer the knife Flow petrol cutter</u> <p>xxvi. Wire Finder</p> <ul style="list-style-type: none"> • <u>To bowl the wire during fishing operation</u> 				
--	------------------------------------------------------------------------------------------------------------------------------------------------------------------------------------------------------------------------------------------------------------------------------------------------------------------------------------------------------------------------------------------------------------------------------------------------------------------------------------------------------------------------------------------------------------------------------------------------------------------------------------------------------------------------------------------------------------------------------------------------------------------------------------------------------------------------------------------------------------------------------------------------------------------------------------------------------------------------------------------------------------------------------------------------------------------------------------------------------------------------------------------------------------------------------------------------------------------------------------------------------------------------------------------------------------------------------------------------------------------------------------------------------------------------------------------------------------------------------------------------------------------------------------------------------------------------------------------------------------------------------------------------------------------------------------------------------------------------------------------------------------------------------------------------------------------------------------------------------------------------------------	--	--	--	--

	<p>xxvii. Wireline Grab</p> <ul style="list-style-type: none"> • <u>To catch the end of wire during fishing operation</u> <p>xxviii. Hydrostatic Bailer</p> <ul style="list-style-type: none"> • <u>A hydrostatic bailer is run to recover sand/debris from inside a plug and around the fishing neck which normal bailing cannot recover</u> <p>xxix. Sand Pump Bailer</p> <ul style="list-style-type: none"> • <u>Occasionally wireline service involves sand bailing prior to the actual pulling or setting of subsurface flow control devices.</u> <p>xxx. Thread Cross Over</p> <ul style="list-style-type: none"> • <u>To make up toolstring with different type or size.</u> 			
--	-------------------------------------------------------------------------------------------------------------------------------------------------------------------------------------------------------------------------------------------------------------------------------------------------------------------------------------------------------------------------------------------------------------------------------------------------------------------------------------------------------------------------------------------------------------------------------------------------------------------------------------------------------------------------------------------------------------------------------------------------	--	--	--



	<p>37. What do PULLING and RUNNING tools mean?</p> <ul style="list-style-type: none"> • Pulling tools are designed to remove various subsurface equipment from the well and sometimes use for running subsurface equipment. This pulling tool can only retrieve the subsurface equipment with the matching fishing neck. 				
	<p>38. How to connect the following tool string in HORIZONTAL & VERTICLE position: <u>From top – 1 – ½” Rope Socket, 1 – ½ x 5’ Wireline Stem, 1- ½ “ Knuckle Joint, 1 – ½ “ x 20” Mechanical Spang Jar</u></p>				
	<p>39. Why is Fishing Neck appear at wireline tools</p> <ul style="list-style-type: none"> • The pulling tools ability to latch that fishing neck if the tool string or component are lost in the hole. 				

	<p>40. List down 20 Hand Tools in Dimension Bid and explain when and how to use them</p> <ol style="list-style-type: none"> 1. 1.24' pipe wrench 2. adjustable 8" and 12" 3. screw driver plate and philip 4. Hammer 5. allen key inches and mm 6. Packing fuller 7. Hand pump for martin decker 8. Vice grip 10" 9. wire cutter 10. Pile 11. Plier long nose or normal 12. Pipe wrench 8" 13. combination ring spanner 17mm and 19mm 14. Pin punch 15. center punch 16. junior hack saw 17. Ratchat and socket 17mm 18. Triangle pile 			
--	----------------------------------------------------------------------------------------------------------------------------------------------------------------------------------------------------------------------------------------------------------------------------------------------------------------------------------------------------------------------------------------------------------------------------------------------------------------------------------------------------------------------------------------------------------------------------------------------------------------------------------------------------------------------------------------------------------------	--	--	--

	19.Chain tong 24" 20.Vice grip wrench				
	41. Why it is Compulsory to screw -in by hand before tightening wireline tool with pipe wrench <ul style="list-style-type: none"> • <u>To prevent the thread damage</u> 				
FORM C.3	EQUIPMENT MAINTENANCE AND SERVICNG				
	1. What is equipment maintenance about and what is the frequency of surface equipment, single well control panel and wireline unit. <ul style="list-style-type: none"> • <u>Equipment maintenance is about maintaining the equipment so as to prolong the life span, while ensuring the integrity good, save cost an upholding the company image to run the contract smoothly.</u> 				
	2. Why is it important to maintain your equipment at all time? <ul style="list-style-type: none"> • <u>To save cost</u> • <u>To prevent from downtime</u> • <u>To avoid equipment failure during the operation because can cause down time.</u> • <u>And work can proceed with successfully.</u> 				

	<p>3. If you found expired equipment offshore, what should you do?</p> <ul style="list-style-type: none"> • <u>Arrange to send back to shore</u> • <u>Inform worksite supervisor and Labuan workshop supervisor sending by e-mail. Find out boat schedule from North Sabah (ask MATCO) make hard copy 3 pcs. Attached COG inside the box wire line equipment.</u> 				
	<p><u>Wireline unit maintenance</u></p> <p>4. Prior to sending out of wireline unit to offshore what are the check list to look for Zone 2 compliance.</p> <ul style="list-style-type: none"> • <u>inlet flame trap</u> • <u>Fuel shut off valve (automatic)</u> • <u>High coolant water temperature shut down at least than 100`c</u> • <u>Low oil pressure shut down</u> • <u>Antistatic fan belts</u> • <u>Nonmetallic blow fan</u> • <u>Resilient engine shock mounts</u> • <u>Emergency stop facility which functions shut down system</u> • <u>Max surface and exhaust gas temp. is maintained at less than 200`c.</u> • <u>Engine throttle and engine stop control pneumatically from the operator rated as per BP200 & EEMUA 107 STD</u> 				

	<p>5. What do you check and why for the following items:-</p> <ul style="list-style-type: none"> i. exhaust flame trap <ul style="list-style-type: none"> • <u>Check the carbon build up took place inside the exhaust system</u> • <u>The cleaning process of the exhaust man cooler flame trap will improve the exhaust gas flow efficiency and reinstate the engine optimum performance.</u> • <u>Exhaust spark arrestor Inspect the condition of the spark arrestor (such as sign of broken, leaking and clogged)</u> • <u>Remove the spark arrestor to clean sooty deposits from the interior by tapping and inverting.</u> ii. exhaust spark arrestor <ul style="list-style-type: none"> • <u>Check the belt condition for any excessive wear and tear. Replace as necessary</u> • <u>Check the correct tension setting on the belt</u> • <u>Adjust if required to allow ½ free play</u> • <u>Ensure the rotating parts/pulleys are free from contact with the stationary parts.</u> iii. static fan belt <ul style="list-style-type: none"> • <u>Check for dirty oil stain and blow with compressed air</u> • <u>When replacing an engine breather flame trap make sure all joints are well sealed.</u> iv. flame trap of engine breather <ul style="list-style-type: none"> • <u>Check the integrity of all the pipe work, joints connection of the induction and exhaust system.</u> • <u>Only the trained mechanic authorized to perform emergency shutdown to inspect for leakage and confirm the engine induction system is sealing alright.</u> v. Joints, connections of induction, exhaust and fuel system of the engine. <ul style="list-style-type: none"> • <u>Check the integrity of all the pipe work, joints connection of the induction and exhaust system.</u> 				
--	--------------------------------------------------------------------------------------------------------------------------------------------------------------------------------------------------------------------------------------------------------------------------------------------------------------------------------------------------------------------------------------------------------------------------------------------------------------------------------------------------------------------------------------------------------------------------------------------------------------------------------------------------------------------------------------------------------------------------------------------------------------------------------------------------------------------------------------------------------------------------------------------------------------------------------------------------------------------------------------------------------------------------------------------------------------------------------------------------------------------------------------------------------------------------------------------------------------------------------------------------------------------------------------------------------------------------------------------------------------------------------------------------------------------------------------------------------------------------------------------------------------------------------------------------------------------------------------------------------------------------------------------------------------------------------------------------------------------------------------------------------------------------------------------------------------------------------------------------------------------------------------------------------------------------------------------------------------------------------------------------------------------------	--	--	--	--

	<ul style="list-style-type: none"> • <u>Only the trained mechanic authorized to perform emergency shutdown to inspect for leakage and confirm the engine induction system is sealing alright.</u> vi. non- metallic cooling fan blades, belt/s and pulleys • <u>Ensure the blades are free of rotation without contact the nearby stationary parts, Adjust as required.</u> 				
	<p>6. Why do you keep minimum stock level of critical spares offshore?</p> <ul style="list-style-type: none"> • <u>To avoid non-productive time (NPT)</u> • <u>To avoid long lead to order spare parts</u> • <u>Offshore location is isolated and thus a need to be self-sufficient and contained to further enhance performance.</u> 				
	<p>7. What do you do with aging, tear and worn-out wireline tools offshore?</p> <ul style="list-style-type: none"> • <u>Tag and mark the DO NOT USE and keep is aside in the isolated area.</u> • <u>Arrange to send back</u> • <u>Inform worksite supervisor and Labuan workshop supervisor sending by E-mail. Attached COG</u> • <u>Request for tool replacement.</u> 				

	<p>8. For the wireline diesel power pack to operate in Zone 2 Hazardous Areas, and as per EEMUA 107, what are the safety features that are required to be incorporated into the power pack? <i>(Answer in bullets points)</i></p> <ul style="list-style-type: none"> • <u>Exhaust gas cooler</u> • <u>Exhaust spark arrestor (Stainless steel)</u> • <u>Sealed crankcase dip stick</u> • <u>Crankcase Breather flame trap</u> • <u>Secured oil filler cap</u> • <u>Automatic engine over speed shut down inlet valve</u> • <u>Inlet flame trap</u> • <u>Fuel shut off valve automatic operates with all shut down</u> • <u>High coolant water temperature shut down at less than 100`c-Low oil pressure shut down</u> • <u>Anti-static fan belt</u> • <u>Non-metallic blow fan</u> • <u>Resilient engine shock mounts</u> • <u>Emergency stop facility which functions shut down system</u> • <u>Max surface and exhaust gas temp is maintained at less than 200`c engine</u> • <u>Engine throttle and engine stop control pneumatically from the operator console.</u> • <u>Engine starting system (hydraulic / pneumatics / spring rewind)</u> • <u>Engine instrumentation includes engine coolant temperature gauge, exhaust gas temperature gauge, engine oil pressure gauge and RPM /hour meter on board power pack skit.</u> 				
--	---------------------------------------------------------------------------------------------------------------------------------------------------------------------------------------------------------------------------------------------------------------------------------------------------------------------------------------------------------------------------------------------------------------------------------------------------------------------------------------------------------------------------------------------------------------------------------------------------------------------------------------------------------------------------------------------------------------------------------------------------------------------------------------------------------------------------------------------------------------------------------------------------------------------------------------------------------------------------------------------------------------------------------------------------------------------------------------------------------------------------------------------------------------------------------------------------------------------------------------------------------------------------------------------------------------------------------------------------------------------------------------------------------------------------------------------------------------------------------------------------------	--	--	--	--



	<p>9. How do you hook up and operate the hydraulic mast to the power pack?</p> <ul style="list-style-type: none"> • <u>The hydraulic hose connection in the power pack are hook up in reciprocal to hydraulic mast connection in sequence of mast /Rsu pressure, mast /rsu return and mast/rsu case drain</u> • <u>Ensure all connection are made up properly and correctly</u> • <u>Positioned the lever switch to hydraulic mast and pull out knob to mast and BOP mode</u> • <u>Ensure external power pack is running</u> • <u>Engage lever to mast erect function to erect mast.</u> • <u>Select winch function to lower hook</u> • <u>Ready for rig up wire line lubricator</u> 				
<p>EQUIPMENT MAINTENANCE AND SERVIC</p>					

	<p>10. What must you do before hooking up the hydraulic hoses to the unit or mast?</p> <ul style="list-style-type: none"> • <u>Connect lines correctly. A wrong hook up of lines causes the reverse of the intended action. This may result in an unexpected action and could lead to serious injuries.</u> • <u>Check hoses, fittings etc. on a regular basis and replace if worn or damaged. Carelessly servicing, adjusting or replacing parts can be result in serious injury.</u> • <u>Never service or adjust system under pressure. Always ensure that the hydraulics system is shut down and bleed before performing maintenance of any kind.</u> • <u>Never try to detect a pinhole leak by running your hand over the area where you suspect the leak to be. Always use a piece of cardboard and always wear safety glasses or a face shield.</u> • <u>Always relieve the pressure before disconnecting hydraulic lines. Tighten all connection before applying pressure. Escaping fluid under pressure can penetrate the skin causing serious injury.</u> • <u>Flammable spray can be produced by generating heat near pressurized fluid lines which can be result in burns. Do not weld, solder, or use a torch near the pressurized lines. -Heat from the sun can cause thermal expansion of hydraulic oil in a closed system, which increases the pressure in the system. The increases pressure can blow seals and move unexpectedly.</u> 				
--	----------------------------------------------------------------------------------------------------------------------------------------------------------------------------------------------------------------------------------------------------------------------------------------------------------------------------------------------------------------------------------------------------------------------------------------------------------------------------------------------------------------------------------------------------------------------------------------------------------------------------------------------------------------------------------------------------------------------------------------------------------------------------------------------------------------------------------------------------------------------------------------------------------------------------------------------------------------------------------------------------------------------------------------------------------------------------------------------------------------------------------------------------------------------------------------------------------------------------------------------------------------------------------------------------------------------------------------------------------------------------------------------------------------------------------------------------------------------------------------------------------------------	--	--	--	--

	<p><u>Wireline surface equipment</u></p> <p>11. How does the BOP operate and how do you change the ram? Name how many type of BOP and rams.</p> <ul style="list-style-type: none"> • <u>2 type of BOP :</u> • <u>Single ram BOP and double ram BOP.</u> • <u>BOP operated when new hyd. Supplied fitted with gas vented hydraulic cylinder, close to the BOP body, prevent gas from passing the o-ring seal on the stem. Any gas reaching the hydraulic cylinder can cause the following:</u> • <u>1-Gas mixers hydraulic fluid which can pressurized the hose and pump above their rated pressure.</u> • <u>2-Gas can cause the hydraulic fluid to expend and cause the rams to open.</u> • <u>RAMS TYPE:</u> • <u>a) slick line (0.092", 0.108", 0.125") use blind rams with rubber inserts on the sealing to seal with or without wire across the rams.</u> • <u>b) Braided line (3/16, ¼ or conductor cable) use rams with a semicircular groove in the seals to match the line diameter.</u> • <u>Testing BOP</u> • <u>All BOP's must be function- and pressure tested after assembly</u> • <u>WITH THE RAM OPEN-Pressure to 150% of working pressure</u> • <u>WITH RAMS OPEN- Pressure 100% of working pressure to test rams seal against wire diameter.</u> • <u>NOTE: A welded and certified test rod, of the same size and wire to be used should be inserted between the rams.</u> • <u>IMPORTANT; The force created by the pressure acting on the cross-sectional area of the test rod will act to push the rod out of the rams. For this reason it must be subjected to recognized welding certification.</u> • <u>The correct pressure testing procedure will highlight any assembly errors such as the pin and box connection being inverted during reassembly.</u> • <u>Testing Hydraulic BOPs</u> • <u>Hydraulic cylinders in place of the end caps permit the rams to be operated remotely.</u> • <u>Prior to opening the cylinders observe the following precaution.</u> • <u>The rams should be in the fully open position.</u> • <u>Bleed all pressure from the cylinders using the pump's internal directional valve or by snapping an open male and female fitting into the quick con</u> 				
--	------------------------------------------------------------------------------------------------------------------------------------------------------------------------------------------------------------------------------------------------------------------------------------------------------------------------------------------------------------------------------------------------------------------------------------------------------------------------------------------------------------------------------------------------------------------------------------------------------------------------------------------------------------------------------------------------------------------------------------------------------------------------------------------------------------------------------------------------------------------------------------------------------------------------------------------------------------------------------------------------------------------------------------------------------------------------------------------------------------------------------------------------------------------------------------------------------------------------------------------------------------------------------------------------------------------------------------------------------------------------------------------------------------------------------------------------------------------------------------------------------------------------------------------------------------------------------------------------------------------------------------------------------------------------------------------------------------------------------------------------------------------------------------------------------------------------------------------------------------------------------------------------------------------------------------------------------------------------------------------------------------------------------------------------------------------------------------------------------------------------------------------------------------------------------------------------------------------------------------------------------------------------------------------------------------------------------------------------------------------------------------------------------------	--	--	--	--

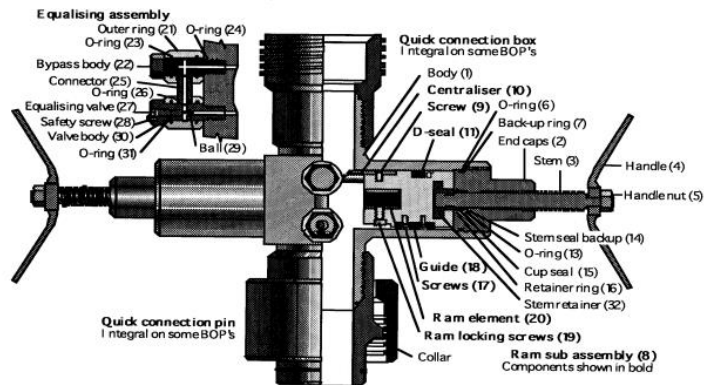

Ram disassembly

- Remove the screws (17) and guide (18)
- Remove the screws (9) and centralizer (10)
- Remove the D seal (11)
- Remove the ram locking screws (19) and ram Element (20)
- Clean and inspect all parts thoroughly for Damage or wear. Discard all old o ring, seals And elements.

Repeat the steps with the other side of the BOP Assembly procedure

Replace all old o rings, seals and elements.

Ram assembly

- Install the ram element (20) and ram locking Screw (19)
- Install the D seal (11)
- Install the centralizer (7) and retain with screw (9)
- Place the guide (18) in the ram slot on the Bottom of ram and retain with screw (17) put The ram a side this time.

	<p>TESTING Hydraulic BOPs</p> <ul style="list-style-type: none"> • <u>Hydraulic cylinders in place of the end caps permit the rams to be operated remotely.</u> • <u>Prior to opening the cylinders observe the following precautions:</u> • <u>The rams should be in the fully open position.</u> • <u>Bleed all pressure from the cylinders using the pump's internal directional valve or by snapping an open male and female fitting into the quick connections</u> 				
	<p>12. How do you change the stuffing box packing?</p> <ul style="list-style-type: none"> • <u>Removed the packing nut and upper gland.</u> • <u>Removed the packing with the packing extractor.</u> • <u>New packing should be reamed on piece of wire of the diameter to be used, and roughened up with cutter plies of from a file.</u> • <u>Insert this wire through the lower packing gland and push each new piece of packing into position with a piece of 3/16" brass pin.</u> • <u>Replace the upper packing gland and packing nut.</u> • <u>The wire can be removed or remain in place during transportation.</u> 				
	<p>13. What must you do if there is a leak in the hydraulic system in SWCP and how do you know when there is a leak.</p> <ul style="list-style-type: none"> • <u>Isolated and stop the pump</u> • <u>Clean and removed the panel both inside and out so as to be able to observed any leaks</u> • <u>Test the panel to 4000 psi and check all the joints carefully and that all the internal valves are holding the pressure</u> • <u>Repair any minor leaks and replace any minor component as necessary.</u> • <u>Note: any major component overhauls are done by the Labuan workshop</u> • <u>Change the oil (Tellus-46)</u> • <u>Re-pressured test after replacement of any parts or after breaking any connection</u> 				



	<p>14. What is SWL? Where do you find this?</p> <ul style="list-style-type: none">• <u>SWL is safe working load of equipment indicating the tested load done by third party.</u>• <u>These are found in RSU, PP, Lubricator Skid, Lubricator, Stuffing Box, Hyd. mast and w/line toolbox, Gantry crane and permanent gin pole.</u>				
--	-----------------------------------------------------------------------------------------------------------------------------------------------------------------------------------------------------------------------------------------------------------------------------------------------------------------------------------------------------------	--	--	--	--

	<p>15. Explain in steps how you service the following wireline tools</p> <p>i. Pulling tool GS Pulling tools :</p> <p><u>1-Place the cylinder in a vice.</u> <u>2- Un screw the top sub for enough to expose the sheared pieces</u> <u>Of the shear pin</u> <u>3- Remove the set screw and unscrew the fish neck from the core</u> <u>4- Pull the core out through the lower end of the cylinder</u> <u>5 - Remove the top sub this allows the cylinder spring, spring retainer 90 dog</u> <u>spring dog retainer AND DOGS to be removed from the cylinder.</u> <u>6- Clean and inspect all parts thoroughly.</u></p> <p>ii. Running tool X Line Running Tool</p> <p><u>1-Remove the locking pin and retainer pin and withdraw the core.</u> <u>2- Remove the fishing neck retainer dog</u> <u>3-Hold the tool in the vice by the fishing neck. Vertically and back off the dog</u> <u>retainer from the main spring housing</u> <u>NOTE: Use strap wrenches to prevent deformation of thin walled main spring.</u> <u>5-Remove the dog retainer and split rings</u> <u>6-Unscrew the main mandrel slot.</u> <u>NOTE: These are matched pair- NOT INTERCHANGABLE if the tool is not going</u> <u>to be reassembled immediately store these two components</u> <u>Screw together.</u> <u>7- Remove the spring housing and main spring.</u> <u>8- Remove the dog spring by squeezing flat between the two hacksaw blade.</u> <u>twisting vertically and drawing through the slot into the retainer housing.</u> <u>9- Wash all parts with diesel, degreaser and then rinse with water. Check all</u> <u>parts for wear grease lightly.</u></p> <p>iii. Positioning tool X Shifting Positioning tool</p> <p><u>1- Place the mandrel in a vice.</u> <u>2- Loosen the set screw</u></p>				
--	--------------------------------------------------------------------------------------------------------------------------------------------------------------------------------------------------------------------------------------------------------------------------------------------------------------------------------------------------------------------------------------------------------------------------------------------------------------------------------------------------------------------------------------------------------------------------------------------------------------------------------------------------------------------------------------------------------------------------------------------------------------------------------------------------------------------------------------------------------------------------------------------------------------------------------------------------------------------------------------------------------------------------------------------------------------------------------------------------------------------------------------------------------------------------------------------------------------------------------------------------------------------------------------------------------------------------------------------------------------------------------------------------------------------------------------------------------------------------------------------------------------------------------------------------------------------------------------------------------------------------------------------------------------------------------------------------------------------------------------------------------------------------------------------------------------------------------------------------------------------------------------------------------------------------------------	--	--	--	--

	<p><u>3- Remove the key retainer from the mandrel. Remove the set screw and nylon ball from the key retainer.</u></p> <p><u>4-Remove the key spring dogs and slip ring weldment as a unit.</u> <u>NOTE: The slip ring weldment may have to be indexed in the "J" slot Arrangement before removing this unit.</u></p> <p><u>5- Remove the spring from the key.</u></p> <p><u>6-Remove the dogs from the slips rings weldments</u></p> <p><u>8- Clear and inspect all the parts for wear or damage.</u></p> <p>iv. Circulation and flow control device <u>Slide sliding door</u> <u>SSD are installed to provide the following communication:</u></p> <ul style="list-style-type: none"> <u>To bring a well into production after drilling or workover operation by circulating the completion fluid into the casing and replacing it with a lighter fluid in the tubing.</u> <u>To kill a well prior to pulling the tubing during a workover operation.</u> <u>To allow selective zone production in a multiple zone well completion.</u> <p>When selecting the SSD for a completion string, the following should be noted: SSD type</p> <table border="1" style="width: 100%; text-align: center;"> <thead> <tr> <th>Open up</th> <th>Open down</th> </tr> </thead> <tbody> <tr> <td>"AO"</td> <td>"XO"</td> </tr> <tr> <td>"XA"</td> <td>"RO"</td> </tr> <tr> <td>"RA"</td> <td>"X"</td> </tr> <tr> <td>"L"</td> <td>"RD"</td> </tr> </tbody> </table> <p>Flow Control Devices Flow control device in these aspects is focus to devices that control the direction of flow once they are set in the tubing(nipple) that is plug assembly. These plugs shall be assembled together with lock mandrel, which in turn make up the whole flow control assembly. The plug is divided into three categories.</p> <ul style="list-style-type: none"> Plugs that hold pressure from above. Plugs that hold pressure from below. Plugs that hold pressure from both ways. <p>Plugs must have two important criteria in order for them to serve the purpose.</p> <ul style="list-style-type: none"> Sealing capability 	Open up	Open down	"AO"	"XO"	"XA"	"RO"	"RA"	"X"	"L"	"RD"			
Open up	Open down													
"AO"	"XO"													
"XA"	"RO"													
"RA"	"X"													
"L"	"RD"													

	<ul style="list-style-type: none"> Equalizing capability <p>Sealing elements are used to isolate the pressure. These elements are normally made up of high quality and durable rubber and vee-packings are often used for this purpose. All plug assemblies run in hole must be equipped with equalizing device for retrieving purpose in order to avoid blown up. This equalization must occur fully before unlocking lock mandrel.</p> <p><u>'X' & 'XN' Plugs</u></p> <p><u>The 'XX' and 'XN' plugs are identical. The no-go shoulder is designed to pass the 'X' nipple profile and locate on the 'XN' nipple no-go ring below the polished packing bore. These plugs are designed to be run in clean production wells attached to an 'X' or 'XN' lock mandrel. The 'PX' equalizing sub is similar in external appearance. They can be identified by the position of the equalizing ports. On the XX & XN, the ports are close to the no-go shoulder whereas on the PX & PXN, they are in the Centre of the body.</u></p>				
	<p>16. Show how to carry out the following basic maintenance:</p> <ol style="list-style-type: none"> i. <u>Greasing bearing</u> i. <u>Grease the nipple using grease gun</u> ii. <u>Re-tighten bolt and nut</u> ii. <u>Retighten the bolt with ring spanner.</u> iii. <u>Lubricate wire while RIH</u> iii. <u>Fill up the oil tank for lubricate the wire and open the valve tank.</u> iv. <u>Re-Tension Dual Drive Chain</u> v. <u>Lubricate Odometer and Odometer Cable</u> iv. <u>Keep oil inside the odometer cable</u> vi. <u>Protect bolt, nut, fitting etc with Denso Tape (Grease Tape)</u> 				

	<p>17. What should you check BEFORE operating the Reel Skid Unit (Show the start-up Maintenance Checklist and understand the requirements)</p> <ul style="list-style-type: none"> • <u>Operating a reel skid unit, commonly used in the oil and gas industry or other applicator involving the handling of hoses, cables, or similar materials, requires a thorough start-up maintenance checklist to ensure safety and optimal performance. Here is a general checklist that can be adapted based on the specific design and requirements of the reel skid.</u> <ol style="list-style-type: none"> 1. <u>Visual inspection</u> 2. <u>Control panel</u> 3. <u>Documentation review</u> 4. <u>Brakes system</u> 5. <u>Safety precaution</u> 6. <u>Hoses and cables</u> 7. <u>Hydraulic</u> 8. <u>Lubrication</u> 9. <u>Reel and drum inspection</u> 10. <u>Emergency procedures</u> 11. <u>Drive system</u> 12. <u>Function test</u> 13. <u>Gear box</u> 14. <u>Chain condition</u> 			
--	---------------------------------------------------------------------------------------------------------------------------------------------------------------------------------------------------------------------------------------------------------------------------------------------------------------------------------------------------------------------------------------------------------------------------------------------------------------------------------------------------------------------------------------------------------------------------------------------------------------------------------------------------------------------------------------------------------------------------------------------------------------------------------------------------------------------------------------------------------------------------------------------------------------------------------------------------------------------------------------------------------------------------------------------------------------------------------------------------------------------------------------	--	--	--

	<p>18. Show how to carry-out following basic maintenance</p> <ol style="list-style-type: none"> i. Protect bolt, nut, fittings etc with Denso Tape (Grease Tape) ii. Re-tighten bolt & nut iii. Protect 1" & 1 – ¼ " Hydraulic Hose connection iv. Take –out Air Starter from ‘Crane Case’ v. Clean – up Air Filter with air vi. Re – tension Fan Belt 				
	<p>19. What should you check BEFORE start the Power Pack (Show the Start – Up Maintenance Checklist and understand the requirement)</p> <ul style="list-style-type: none"> • <u>Check hydraulic tank suction line ball valve fully open</u> • <u>Check hydraulic oil level in hydraulic tank is up to minimum level is less top-up.</u> • <u>Check engine oil level</u> • <u>Check radiator belting condition</u> • <u>Check diesel level in diesel tank if less top-up.</u> • <u>Check air inlet / outlet and exhaust are not blocked.</u> • <u>Check radiator level and coolant. If less top-up.</u> • <u>Check exhaust flame trap is fitted in exhaust heat exchanger after cleaning.</u> • <u>Check accumulator pressure, should be greater than 2500 psi</u> • <u>Check all hydraulic hoses and quick connectors for any leaking.</u> • <u>Check any leaking on the PP body while the engine is running.</u> 				

	<p>20. What are the safety precautions to be alert while Air Compressor running?</p> <ul style="list-style-type: none"> • <u>Operating an air compressor requires careful attention to safety precautions to prevent accidents and ensure the well-being of individuals in the vicinity. Here are some key safety precautions to be aware of while an air compressor is running.</u> <p>Read the manual</p> <ul style="list-style-type: none"> • <u>Familiarize yourself with the manufacturer’s instructions and safety guidelines provided in the user manual.</u> <p>Location</p> <ul style="list-style-type: none"> • <u>Place the air compressor on a stable, flat surface to prevent tipping. Ensure proper ventilation in the operating area to prevent the building of fumes or gases.</u> <p>Personal Protective Equipment (PPE)</p> <ul style="list-style-type: none"> • <u>Wear appropriate PPE, including safety glasses or goggles, hearing protection, and any other equipment recommended by the manufacturer.</u> <p>Electrical Safety</p> <ul style="list-style-type: none"> • <u>Use grounded electrical outlets and extension cords. Regularly inspect power pack cords for damage and replace them if necessary. Keep electrical components away from water to avoid electrical shocks.</u> <p>Pressure Relief</p> <ul style="list-style-type: none"> • <u>Before performing maintenance or disconnecting hoses, release the air pressure in the system using the pressure relief valve.</u> <p>Hose Inspection</p>				
--	-----------------------------------------------------------------------------------------------------------------------------------------------------------------------------------------------------------------------------------------------------------------------------------------------------------------------------------------------------------------------------------------------------------------------------------------------------------------------------------------------------------------------------------------------------------------------------------------------------------------------------------------------------------------------------------------------------------------------------------------------------------------------------------------------------------------------------------------------------------------------------------------------------------------------------------------------------------------------------------------------------------------------------------------------------------------------------------------------------------------------------------------------------------------------------------------------------------------------------------------------------------------------------------------------------------------------------------------------------------------------------------------------------------------------------------------------------------------------------------------------------------------------------------------------------------------------------------------------------------------------------------------------------------------------------	--	--	--	--

	<ul style="list-style-type: none"> • <u>Regularly inspect air hose for wear, damage, or leaks. Use proper fittings and secure connections to prevent accidental disconnection.</u> <p>Automatic Stop</p> <ul style="list-style-type: none"> • <u>Ensure that the compressor is equipped with an automatic stop feature to shut off when the desired pressure level is reached.</u> <p>Noise Levels</p> <ul style="list-style-type: none"> • <u>Wear hearing protection, especially in environments where noise levels exceed safe limits. Secure tools and accessories. Securely fasten tools and accessories to the air hose to prevent them from becoming projectiles.</u> <p>Cooling System</p> <ul style="list-style-type: none"> • <u>Keep the compressor’s cooling system clean and unobstructed to prevent overheating.</u> <p>Maintenance</p> <ul style="list-style-type: none"> • <u>Perform regular maintenance as outlined in the user manual. Keep the compressor clean and free from debris.</u> <p>Emergency Shutdown</p> <ul style="list-style-type: none"> • <u>Know the location of the emergency shut-off switch. Be familiar with emergency procedures in case of malfunction or accidents.</u> <p>Training</p> <ul style="list-style-type: none"> • <u>Ensure the operators are adequately trained in the safe operation of the air compressor. Restrict access to authorized personnel only.</u> <p>Pressure Gauges</p> <ul style="list-style-type: none"> • <u>Regularly check pressure gauges to ensure they are functioning accurately.</u> <p>First Aid Kit</p> <ul style="list-style-type: none"> • <u>Have a well-stocked first aid kit available in case of injuries.</u> 				
--	------------------------------------------------------------------------------------------------------------------------------------------------------------------------------------------------------------------------------------------------------------------------------------------------------------------------------------------------------------------------------------------------------------------------------------------------------------------------------------------------------------------------------------------------------------------------------------------------------------------------------------------------------------------------------------------------------------------------------------------------------------------------------------------------------------------------------------------------------------------------------------------------------------------------------------------------------------------------------------------------------------------------------------------------------------------------------------------------------------------------------------------------------------------------------------------------------------------------------------------------------------------------------------------------------------------------------------------------------------------------------------------------------------------------------------------------------------------------------------------------------------------------------------------------------------------------------------------------------------------------------------------------------------------------------------------------------------------------------------------------------------------------------------------------------------------------------------------------------------------------------------------------------	--	--	--	--



--	--	--	--	--	--

	<p>21. Why contaminated water should be drained from Compressor Tank before start the Air Compressor?</p> <ul style="list-style-type: none"> • Draining contaminated water from the compressor tank before starting the air compressor is essential maintenance practice. <p>Condensation Accumulation</p> <ul style="list-style-type: none"> • <u>Compressed air system generate heat during operation, and as the air compressor air cools down, condensation forms inside the compressor tank. This condensation can accumulate over time and result in the formation of water at the bottom of the tank.</u> <p>Water is a Contaminant</p> <ul style="list-style-type: none"> • <u>Water in the compressed air can lead to various issues. It can mix with the lubricant in the system, causing them to break down and reduce their effectiveness. Water can also corrode the interior of the tank and other components.</u> <p>Corrosion Prevention</p> <ul style="list-style-type: none"> • <u>The presence of water in the tank can contribute to the corrosion of the tank itself and internal components. Corrosion compromises the structural integrity of the tank, leading to potential safety hazards and reducing the overall lifespan of the equipment.</u> <p>Tool and Equipment Damage</p> <ul style="list-style-type: none"> • <u>If water is allowed to enter the compressed air supply, it can damage pneumatic tools and equipment. Water in the air stream can cause rust, clog filters, and the performance of air-powered tools.</u> <p>Air Quality</p> <ul style="list-style-type: none"> • <u>Water in the compressed air system can carry contaminants and particulate matter. Draining the water helps maintain better air quality, reducing the risk of contaminating products or process that rely on clean, dry air.</u> <p>Preventing Freezing</p> <ul style="list-style-type: none"> • <u>In colder climates, the water that accumulates in the tank can freeze, causing damage to the tank and associated components. Draining the water helps prevent freezing issues.</u> 				
--	------------------------------------------------------------------------------------------------------------------------------------------------------------------------------------------------------------------------------------------------------------------------------------------------------------------------------------------------------------------------------------------------------------------------------------------------------------------------------------------------------------------------------------------------------------------------------------------------------------------------------------------------------------------------------------------------------------------------------------------------------------------------------------------------------------------------------------------------------------------------------------------------------------------------------------------------------------------------------------------------------------------------------------------------------------------------------------------------------------------------------------------------------------------------------------------------------------------------------------------------------------------------------------------------------------------------------------------------------------------------------------------------------------------------------------------------------------------------------------------------------------------------------------------------------------------------------------------------------------------------------------------------------------------------------------------------------------------------------------------------------------------------------------------------------------------------------------------------------------------------------------------------------------------------------------------------------------------------------------------------------------------------------------------------------------------------------------------------------------------------------------------------------------------------------------------------------------------------------------------------------------------	--	--	--	--

	<p>Efficiency and Performance</p> <ul style="list-style-type: none"> • <u>A compressor that operates with a clean, dry tank and air system is more efficient and performs better. Removing water from the tank ensures that the compressor can deliver the expected pressure and airflow.</u> <p>Extended Equipment life</p> <ul style="list-style-type: none"> • <u>Regular maintenance, including draining water from the tank, contributes to the longevity of the compressor, it helps prevent premature wear and damage to components.</u> 				
	<p>22. Show how to carry-out following basic maintenance</p> <ol style="list-style-type: none"> Protect bolt, nut, fittings etc with Denso Tape (Grease Tape) Re-tighten bolt & nut Caring of pressure gauge Service Air Operated Pump Exhaust Check Hydraulic Oil Level and fill – up if necessary Release contaminated water from Air Isolator Release pressure in system upon completed job Take – out ¼ “ Snap Tite from Control Panel and service Pressure Manifold to be installed at Control Panel 				

	<p>23. What should you check BEFORE start the Control Panel (Show the Start-Up Maintenance Checklist and understand the requirement)?</p> <ul style="list-style-type: none"> • <u>Check hydraulic through the level indicator</u> • <u>The air filter is drained</u> • <u>Check the validity of the air hose and control line hoses</u> • <u>Ensure that all air valves are off</u> • <u>Ensure all needle valves and air regulators are closed</u> • <u>Hand pump relief valves are closed</u> • <u>Check all tubings, fitting etc. for any sign of damage. Replace if necessary.</u> 				
	<p>24. What are the safety precaution to be alert while operating Control Panel?</p> <ul style="list-style-type: none"> • <u>Operating a control panel, especially in industrial settings, requires adherence to strict safety precautions to prevent accidents, protect personnel, and ensure the proper functioning of the equipment. Here are some general safety precautions to be aware of when operating a control panel.</u> <ol style="list-style-type: none"> I. <u>Training and competency</u> II. <u>PPE</u> III. <u>Environmental consideration</u> IV. <u>Regular maintenance</u> V. <u>Clear labeling</u> VI. <u>Documentation</u> VII. <u>Regular inspection</u> 				
	<p>25. Why contaminated water should be drained from Air Hose before start the Control Panel?</p> <ul style="list-style-type: none"> • <u>Draining contaminated water from an air hose before starting the control panel is important for several reasons, especially in industrial or pneumatic systems. Here are the main reasons for this precaution.</u> <ol style="list-style-type: none"> I. <u>Prevent equipment damage</u> II. <u>Ensure air quality</u> III. <u>Ensure proper functioning</u> IV. <u>Enxtend equipment life</u> V. <u>Protect control panel instruments</u> VI. <u>Enhance safety]</u> VII. <u>Prevent contamination of downstream system.</u> 				

	<p>26. Show how to carry – out following basic maintenance</p> <ol style="list-style-type: none"> i. Protect bolt, nut, fittings etc with Denso Tape (Grease Tape) ii. Re-tighten bolt & nut iii. Caring of pressure gauge iv. Service Air Operated Pump Exhaust v. Check Water Level and fill – up if necessary vi. Release contaminated water from Air Isolator vii. Release pressure in system upon completed job viii. Flush the system with Hydraulic Oil 				
	<p>27. What should you check BEFORE start the Test Pump? (Show the Start – Up Maintenance Checklist and understand the requirement)</p> <ul style="list-style-type: none"> • <u>Before starting a test pump, it's crucial to perform a through start-up maintenance check to ensure the proper functioning of the pump and associated systems. Here are the general start-up maintenances checklist for a test pump.</u> <ol style="list-style-type: none"> I. <u>Review operating manual</u> II. <u>Valve positions</u> III. <u>Safety precaution</u> IV. <u>Pressure relief device</u> V. <u>Visual inspection</u> VI. <u>Seals and gasket</u> VII. <u>Water level</u> VIII. <u>Blees air from system</u> IX. <u>Prime the pump</u> X. <u>Test run in manual mode</u> XI. <u>Check control and instrumentation</u> XII. <u>Training and competency.</u> 				

	<p>28. What are the safety precautions to be alert of while operating Test Pump?</p> <ul style="list-style-type: none"> • <u>Make surer no trap pressure inside the hoses before disconnecting them.</u> • <u>Check all tubings, fittings. For any signs of damage. Replace if necessary.</u> • <u>Ensure all needle valves and air regulators are closed.</u> • <u>Ensure that all air valves are off</u> • <u>The air filter is drained.</u> 				
	<p>29. Why the system should be flushed with Hydraulic Oil?</p> <ul style="list-style-type: none"> • To prevent from trap pressure when pumping the line. 				
	<p>30. Show how to carry – out following basic maintenance</p> <ol style="list-style-type: none"> 1”Air Chicago Coupling Drainage Valve Check Valve Relief Valve Protect following items with Denso Tape – Air Chicago Coupling, Drainage Valve & Relief Valve 				
	<p>31. What is the safety precaution to be alert of during spooling activity?</p> <ul style="list-style-type: none"> • <u>Check all the hook up hoses are correctly connected between spooling device and power pack.</u> • <u>Always secure unit back to suitable fixtures before use</u> • <u>Check all guards are in placed</u> • <u>Check the directional lever is in the central position and that the brake is applied.</u> 				

	<p>32. Show how you perform for the following basic maintenance</p> <ul style="list-style-type: none"> i. Service O ring and O ring set ii. Service Sheave Wheel iii. Greasing Sheave Wheel bearing iv. Greasing Staff Am bearing v. Take-out used Stuffing Box packing vi. Change – out Sheave Wheel bearing 				
	<p>33. Explain the Stuffing Box element to be checked during Pre-Start-up Job</p> <ul style="list-style-type: none"> • <u>Check the packing is not worn out</u> • <u>Check the Bop plunger for wear and freedom of vertical movement</u> • <u>Check the upper and lower brass packing glands for wear</u> • <u>Check the sheave is the correct size</u> • <u>Check the sheave bearings for free spinning and side play</u> • <u>Check the sheave staff for freedom of swivel movement</u> 				
	<p>34. What is the safety precaution to be alert of during handling of Stuffing Box?</p> <ul style="list-style-type: none"> • <u>Monitor and check if any leaking</u> • <u>Inspect check the condition of the packing</u> • <u>Keep work area clean</u> • <u>Use proper technique and hand glove when handling it</u> • <u>Follow manufacture instruction</u> 				

	<p>35. How to identify if the Stuffing Box require Standard Service or H2S Service?</p> <ul style="list-style-type: none"> • <u>Identify whether a stuffing box requires standard service or H2S service involves understanding the operational environment and the potential hazards the equipment may encounter.</u> <ol style="list-style-type: none"> I. <u>Review equipment specifications</u> II. <u>Perform risk management</u> III. <u>Access operational environment</u> IV. <u>Consult safety standards</u> V. <u>Inspect equipment labels</u> 				
	<p>36. Strip the Stuffing Box and service completely (2 times)</p>				
	<p>37. Strip the BOP and service completely (1 time)</p>				
	<p>38. Show how to carry-out following basic maintenance:</p> <ol style="list-style-type: none"> i. Manual Stem ii. Inner and Outer Seal iii. Equalizing Port iv. Box – up thread connection v. Pin & Collar Down Thread Connection vi. Internal BOP body 				

	39. What do you do during mob / de mob BOP from one location to other location				
	40. What are the safety precaution be alert of while BOP running? <ul style="list-style-type: none"> • <u>When running a blowout preventer (BOP), which is critical safety device used in slickline operation to control well pressure and prevent blowouts, it's essential to observe several safety precautions to ensure the protection of personnel and equipment.</u> I. <u>Proper training</u> II. <u>Equipment inspection</u> III. <u>Use personal protective equipment</u> IV. <u>Follow procedures</u> V. <u>Maintain control</u> VI. <u>Emergency response plan</u> VII. <u>Preventive maintenance</u> 				
	41. How to identify if the BOP requires Standard Service or H2S Service? <ul style="list-style-type: none"> • <u>Identify whether a blowout preventer (BOP) requires standard service or H2S service involves understanding the operational environment and the potential hazards the equipment may encounter.</u> I. <u>Review manufacturer specification</u> II. <u>Assess well condition</u> III. <u>Perform risk management</u> IV. <u>Consult industry standards</u> 				

	<p>42. Show how to perform for the following basic maintenance for Lubricator and Pump Joint</p> <ul style="list-style-type: none"> i. Clean – up and greasing internal ii. Service box-up thread and o’ ring seal area iii. Service pin & collar down thread, o’ ring and o’ ring groove iv. Service bleed – off port 				
	<p>43. What is the safety precaution to be alert of during handling lubricator section?</p> <ul style="list-style-type: none"> • <u>Check any damages or corrosion inside the lubricator</u> • <u>Check the condition of the needle valves on the lower section. Redress or replace if necessary.</u> • <u>Visual inspection on the internal bore for corrosion</u> • <u>Check the validity</u> 				
	<p>44. If the Lubricator working pressure is 5000 psi, how many Test Pressure to be carried out?</p> <ul style="list-style-type: none"> • $1.5 \times \text{w.p } 5000 = \underline{7500 \text{ psi}}$ 				
	<p>45. Show how to carry – out following basic maintenance for wellhead x-over</p> <ul style="list-style-type: none"> i. Clean up and greasing internal ii. Service box – up thread and o’ring seal area iii. Service pin & collar down thread, o’ring and o’ring groove 				



	<p>46. What are the safety precautions to be alert of during handling wellhead x-over section and rig –up on top of x-mass tree</p> <ul style="list-style-type: none"> • <u>Handling the wellhead crossover section and rigging up on top of the Christmas tree in oil and gas operation requires strict adherence to safety precaution to prevent accidents and ensure safety of personnel and equipment.</u> <ol style="list-style-type: none"> I. <u>Training and competency</u> II. <u>Full PPE</u> III. <u>Equipment inspection</u> IV. <u>Lifting operation</u> V. <u>Communication</u> VI. <u>Safe handling procedures</u> VII. <u>Valid and inspected used lifting gears</u> 				
	<p>47. Show how to carry – out following basic maintenance for Pump – in Tee</p> <ol style="list-style-type: none"> i. Clean – up and greasing internal ii. Service box – up thread and o’ring seal area iii. Service pin & collar down thread, o’ring and o’ring groove iv. Service 1502 thread and rubber seal 				

	<p>48. What are the safety precaution to be alert during handling Pump – in Tee?</p> <ul style="list-style-type: none"> • <u>Handling a pump-in tee in oil and gas operations requires strict adherence to safety precaution to prevent accidents and ensure the safety of personnel and equipment.</u> <p>I. <u>Training and competency</u> II. <u>PPE</u> III. <u>Equipment inspection</u> IV. <u>Safe handling procedures</u> V. <u>Pressure monitoring</u> VI. <u>Secure work area</u> VII. <u>Communication</u></p>				
Form C.4	EQUIPMENT HANDLING/EQUIPMENT PASSPORT				
	<p>1. What is Material Handling Equipment (MHE)? Name some example:-</p> <ul style="list-style-type: none"> • <u>MHE-material handling equipment. E.g. Forklift, crane, lorry, trailer, jip crane, gantry crane, jack trolley.</u> • <u>MHE is a certified handling equipment to handle or move equipment example w/line units from one place to the another</u> 				
	<p>2. How do you check for expired date of lifting equipment?</p> <ul style="list-style-type: none"> • <u>To check the label attached to the body if the equipment</u> • <u>To check the display of due date, inspection date, MPI date, load test date and etc.</u> • <u>To check the color code on the spindle of the sling.</u> 				

	<p>3. What is Equipment Passport?</p> <ul style="list-style-type: none"> • <u>The equipment passport is a certificate of the equipment. This procedure provides guideline on the process of appointing equipment inspector and the measures required in ensuring all mobile industrial equipment supplied for use in SSB/SSPC. It ensures that such equipment is inadequately fitted with appropriate safety devices</u> <p>The objectives of issuing an equipment passport to each mobile industrial equipment are:-</p> <ul style="list-style-type: none"> • <u>To ensure that the equipment is safe in propose work site or classified hazardous area.</u> • <u>To ensure that all equipment are in good state of maintenance and safety feature such as guards, emergency cut-out device, etc. are in place and in good operating condition.</u> • <u>To ensure that non-approved equipment is tagged (danger –do not use) accordingly to prevent inadvertent use in company areas of operation or contractor sites.</u> 				
--	-------------------------------------------------------------------------------------------------------------------------------------------------------------------------------------------------------------------------------------------------------------------------------------------------------------------------------------------------------------------------------------------------------------------------------------------------------------------------------------------------------------------------------------------------------------------------------------------------------------------------------------------------------------------------------------------------------------------------------------------------------------------------------------------------------------------------------------------------------------------------------------------------------------------------------------------------------------------------------------------------------------------------------------------------------------------------------------	--	--	--	--

	<p>4. List down what are the maintenance schedule for the following:-</p> <p>i. 6-Monthly Planned Maintenance – Wireline Unit Power Pack</p> <ul style="list-style-type: none"> • <u>Carry out test run and diagnose any problems found.</u> • <u>Inspect the power pack unit for leaks and external damage.</u> • <u>Check all connections and mounting bolts.</u> • <u>Change the engine oil and filters regardless of the condition</u> • <u>Check the oil and fluid levels. Top-up to the correct level.</u> • <u>Check the condition of the engine and engine instruments.</u> • <u>Inspect the hose connections and all hydraulic plumbing for leaks.</u> • <u>Check for excessive black smoke; clean or replace the fuel injectors.</u> • <u>Check satisfactory operation of hydraulic recharging pump or spring-type starter mechanism.</u> • <u>Clean the engine crankcase breather and air box drain tubes.</u> • <u>Check the exhaust rain cap is intact and moves freely.</u> • <u>Grease all parts provided with grease nipples and linkages.</u> • <u>Check the fan belts for wear or damage and correct tension.</u> • <u>Check that the inlet shut down valve is functioning and activates automatic shutdown at the maximum engine rpm.</u> • <u>Check that the “AMOT CONTROL” is functioning.</u> • <u>Check the heat exchanger and radiator core for blockage, dirt and condition of fins. Wash thoroughly.</u> • <u>Chip and patch up the corroded parts.</u> • <u>Wash the entire unit with degreaser to remove dirt.</u> • <u>Final inspection/function and load tests prior to storage or dispatch to the work site.</u> <p>ii. 6-Monthly Planned Maintenance – Wireline Unit Power Pack</p> <ul style="list-style-type: none"> • <u>Carry out test run and diagnose the problems if found</u> • <u>Inspect the reel skid for leaks and external damage</u> • <u>Check all connections and mounting bolts</u> • <u>Lubricate all bearings on the reel, transmission drive, lever wind and spool-off device</u> • <u>Change the transmission oil with SPIRAX 90 or equivalent gear oil</u> 				
--	------------------------------------------------------------------------------------------------------------------------------------------------------------------------------------------------------------------------------------------------------------------------------------------------------------------------------------------------------------------------------------------------------------------------------------------------------------------------------------------------------------------------------------------------------------------------------------------------------------------------------------------------------------------------------------------------------------------------------------------------------------------------------------------------------------------------------------------------------------------------------------------------------------------------------------------------------------------------------------------------------------------------------------------------------------------------------------------------------------------------------------------------------------------------------------------------------------------------------------------------------------------------------------------------------------------------------------------------------------------------------------------------------------------------------------------------------------------------------------------------------------------------------------------------------------------------------------------------------------------------------------------------------------------------------------------------------------------------------------------------------------------------------------------------------------------------------------------------------------------------------------------------------------------------------------------------------------------------------------------------------------------------------------------------------------------------------------------------------------------------------------------------------------------------------------------------------------------------------------------------------------------------------------------------------------------------------------------------------	--	--	--	--

	<ul style="list-style-type: none"> • <u>Check for the proper engagement of gears in the transmission. Rectify as necessary</u> • <u>Adjust and lubricate the brake linkage</u> • <u>Lubricate all chains by applying oil with a brush while the chain is running slowly</u> • <u>Check the alignment of the chains and sprockets</u> • <u>Check the condition of the 2/4 way valves, remote control valve, relief valves and check valves. Service as necessary</u> • <u>Check the condition of the jib assembly (if available)</u> • <u>Check the quality of wire by carrying out a torsion twist and ductility test. Lubricate the wire.</u> • <u>Chip and patch up the corroded parts</u> • <u>Wash the entire unit with degreaser to remove dirt</u> • <u>Final inspection/function – and load tests prior to storage or dispatch to the work site.</u> <p>iii. 12-Monthly Planned Maintenance – Wireline Unit Power Pack</p> <ul style="list-style-type: none"> - <u>Conduct a test run on the equipment to determine the required maintenance.</u> - <u>Check for the abnormal condition of the engine at low and high idle. Rectify faults and tune.</u> - <u>Inspect all linkages for smooth operation.</u> - <u>Check for leakage at oil seals, O-rings and gaskets. Replace as necessary.</u> - <u>Check all hydraulic hoses for deterioration. Replace as necessary.</u> - <u>Check the operation of the main hydraulic pump, hydraulic oil cooler, motor, fan and radiator. Repair as necessary.</u> - <u>Change the hydraulic oil and filter (TELLUS T46 or equivalent).</u> - <u>Change the engine oil and filter (RIMULA X30 or equivalent).</u> - <u>Drain any water and sediment form the fuel tank and top-up to the right level. Replace the fuel filter.</u> 				
--	--------------------------------------------------------------------------------------------------------------------------------------------------------------------------------------------------------------------------------------------------------------------------------------------------------------------------------------------------------------------------------------------------------------------------------------------------------------------------------------------------------------------------------------------------------------------------------------------------------------------------------------------------------------------------------------------------------------------------------------------------------------------------------------------------------------------------------------------------------------------------------------------------------------------------------------------------------------------------------------------------------------------------------------------------------------------------------------------------------------------------------------------------------------------------------------------------------------------------------------------------------------------------------------------------------------------------------------------------------------------------------------------------------------------------------------------------------------------------------------------------------------------------------------------------------------------------------------------------------------------------------------------------------------------------------------------------------------------------------------------------------------------------------------------------------------------------------------------------------------------------------------------------------------------------------------------------------------------------------	--	--	--	--

	<ul style="list-style-type: none"> - <u>Thoroughly clean the fins of air-cooled engines. If it is water-cooled, clean the radiator cores.</u> - <u>Check the condition of the radiator and hydraulic heat exchanger. Repair or replace as necessary.</u> - <u>Flush the radiator cooling system, add rust inhibited coolant.</u> - <u>Carry out a performance test on the engine and hydraulic power available.</u> - <u>Run the engine at maximum speed to confirm the inlet shut down valve is functioning.</u> - <u>Check the “AMOT CONTROL” is functioning. Repair or replace if necessary.</u> - <u>Clean, grit blast, undercoat and paint the complete unit.</u> <p>iv. 12-Monthly Planned Maintenance – Wireline Unit Reel Skid</p> <ul style="list-style-type: none"> - <u>During the test run, check the operation of the relief valves, 4-way valve, check valves and remote control valve. Repair or replace as necessary.</u> - <u>Check the tension of the driving chain, sprocket, wire reel and reel brake. Adjust or replace as necessary.</u> - <u>Check the operation of the transmission gear box for unusual noise and abnormal vibration and repair as necessary. Change the SPIRAX HD-90 or equivalent oil.</u> - <u>Check the operation of all linkages and repair as necessary.</u> - <u>Remove the old grease and apply a new coating on all moving parts.</u> - <u>Check all hydraulic hoses for deterioration and/or replace as necessary.</u> 			
--	------------------------------------------------------------------------------------------------------------------------------------------------------------------------------------------------------------------------------------------------------------------------------------------------------------------------------------------------------------------------------------------------------------------------------------------------------------------------------------------------------------------------------------------------------------------------------------------------------------------------------------------------------------------------------------------------------------------------------------------------------------------------------------------------------------------------------------------------------------------------------------------------------------------------------------------------------------------------------------------------------------------------------------------------------------------------------------------------------------------------------------------------------------------------------------------------------------------------------------------------------------------------------------------------------------------------------------------------------------------------------------------------------------------------------------------------------------------------------------------------------------------------------------------------------------------------------------------------------------	--	--	--

	<ul style="list-style-type: none"> - <u>Check for leakage at oil seals, O-rings and gaskets and/or replace as necessary.</u> - <u>Check all couplings for smooth operation.</u> - <u>Check the condition of the jib assembly (if available) and/or repair as necessary.</u> - <u>Replace any defective instrument.</u> - <u>Check the quality of the wire by a torsion twist test. If it is defective, spool-in new wire.</u> <p>v. General Overhaul – Wireline Unit Power Pack</p> <ul style="list-style-type: none"> - <u>Remove the whole engine from its pipe structural transporting skid prior to disassembly.</u> - <u>Grit blast, undercoat and paint the chassis and frame.</u> - <u>Repair any damaged parts and rebuild the structural frame if necessary.</u> - <u>Replace any deteriorated hydraulic hoses.</u> - <u>Flush away any debris and sediment in the fuel/hydraulic tanks before filling in with new fluids.</u> - <u>Calibrate all fuel injectors and injection pumps at the nearest accredited SERVICE DEPOT.</u> - <u>Disassemble the entire engine. Precise measurements are to be taken from all moving parts to check if the "Maximum Advisable Clearance" figure has been reached to justify a replacement.</u> - <u>Replace all seals, O-rings, gaskets and filters regardless of their conditions.</u> - <u>Disassemble/service the axial flow fan and check the blades, pulleys and bearings. Replace any worn parts.</u> 			
--	------------------------------------------------------------------------------------------------------------------------------------------------------------------------------------------------------------------------------------------------------------------------------------------------------------------------------------------------------------------------------------------------------------------------------------------------------------------------------------------------------------------------------------------------------------------------------------------------------------------------------------------------------------------------------------------------------------------------------------------------------------------------------------------------------------------------------------------------------------------------------------------------------------------------------------------------------------------------------------------------------------------------------------------------------------------------------------------------------------------------------------------------------------------------------------------------------------------------------------------------------------------------------------------------------------------------------------------------------------------------------------------------------------------------------------------------------------------------------------------------------------------------------------------------------------------------------------------------------	--	--	--

	<ul style="list-style-type: none"> - <u>Clean the oil cooler and radiator with degreaser and test for leaks. Rectify as necessary.</u> - <u>Service the oil bath air cleaner and filter element with degreaser. Dry and fill with SHELL RIMULA or equivalent oil to the level mark indicated on the filter bowl!</u> - <u>Check for the cylinder head alignment clearance. Correct the clearance as necessary.</u> - <u>Adjust the setting of the decompressor - ¾ turn in and locked in position.</u> - <u>Pressures test the hydraulic starting system @ 2,500 psi for a minimum of 30 minutes to detect any leaks.</u> - <u>Service or recondition the hydraulic vane pump</u> - <u>Check the condition of the belts and pulleys. Change as necessary.</u> - <u>Upon completion of the overhaul, the engine should undergo a performance test for a minimum duration of five hours at idling speed.</u> - <u>Run the engine at maximum speed to confirm the inlet shut down valve is functioning. Calibrate or replace as necessary.</u> - <u>Check the "AMOT CONTROL" is functioning. Repair or replace as necessary.</u> - <u>After the performance test is reported to be satisfactory, the cylinder head bolts and nuts should be re-torque and the valve clearances reset. Re-tighten the nuts, bolts and unions, paying particular attention to the fuel system. Re-check the belt tension but DO NOT OVERTIGHTEN.</u> - <u>Hook up the power pack to another reel skid to carry out a load test of the hydraulic controls.</u> - <u>Calibrate the setting of the hydraulic pressure relief valve to the manufacturer's specifications.</u> <p>vi. General Overhaul – Wireline Unit Reel Skid</p>				
--	-----------------------------------------------------------------------------------------------------------------------------------------------------------------------------------------------------------------------------------------------------------------------------------------------------------------------------------------------------------------------------------------------------------------------------------------------------------------------------------------------------------------------------------------------------------------------------------------------------------------------------------------------------------------------------------------------------------------------------------------------------------------------------------------------------------------------------------------------------------------------------------------------------------------------------------------------------------------------------------------------------------------------------------------------------------------------------------------------------------------------------------------------------------------------------------------------------------------------------------------------------------------------------------------------------------------------------------------------------------------------------------------------------------------------------------------------------------------------------------------------------------------------------------------------------------------------------------------------------------------------------------------------------------------------------------------------------------------------------------------------------------------------------------------------------------------------------------------------------	--	--	--	--

	<ul style="list-style-type: none"> - <u>PRIOR to the overhaul, connect the hydraulic hoses of the reel skid to another power pack to carry out a performance test</u> - <u>Detect and list out all faults which are found during the test</u> - <u>Remove the detachable wire spool from the reel skid then spool-off the used wire using the tensioning unit.</u> - <u>Remove the housing cover from the reel skid in order to carry out the inspection and maintenance</u> - <u>Rectify all faults found in step b. above</u> - <u>Check the condition of all bearings on the reel, transmission drive and measuring head assembly. Replace any worn bearings.</u> - <u>Adjust or replace the brake linkage and/or worn brake lining</u> - <u>Check/replace all worn sprockets and chains</u> - <u>Check/replace deteriorated hydraulic hoses</u> - <u>Check the condition of 2- and/or 4-way valves, non-return valves and remote control valves. Replace as necessary.</u> - <u>Service or recondition the hydraulic vane motor</u> - <u>Check all pressure gauges and replace as necessary</u> - <u>Check the universal coupling and bearing of the steering system and replace as necessary.</u> - <u>Service and load test the detachable hand winch (if available).</u> - <u>Overhaul the transmission gear box and replace Change the gear oil of the transmission gear box.</u> - <u>Service all filters and strainers on the reel skid.</u> - <u>Lubricate all moving parts.</u> - <u>Repair any damaged parts and rebuild the structural frame.</u> - <u>Grit blast, undercoat and paint the entire unit.</u> 			
--	------------------------------------------------------------------------------------------------------------------------------------------------------------------------------------------------------------------------------------------------------------------------------------------------------------------------------------------------------------------------------------------------------------------------------------------------------------------------------------------------------------------------------------------------------------------------------------------------------------------------------------------------------------------------------------------------------------------------------------------------------------------------------------------------------------------------------------------------------------------------------------------------------------------------------------------------------------------------------------------------------------------------------------------------------------------------------------------------------------------------------------------------------------------------------------------------------------------------------------------------------------------------------------------------------------------------------------------------------------------------------------------------------------------------------------------------------------------------------------------------------------------------------------------------------------------------------------------------------------------------------------------------------------------------------------------------------------------------------------------------------------------------------------------------------------	--	--	--

	<ul style="list-style-type: none"> - <u>Service and/or repair the operator seat.</u> - <u>Change the wire spool if required.</u> - <u>Upon completion of the overhaul, carry out a performance test with the aid of another power pack.</u> - <u>Set the pressure relief valves to manufacturer's specification during the test run.</u> - <u>Carry out a function test of the wire line winch as follows:</u> <ul style="list-style-type: none"> o <u>Braking test in 2nd gear</u> o <u>Relief valve maximum setting</u> o <u>Hydraulic brake – if applicable</u> o <u>2-way valve close – relief valve 2,000 psi</u> o <u>Spool in the new wire as per request</u> 				
	<p>5. What is the colour code for lifting equipment?</p> <ul style="list-style-type: none"> • <u>Yellow</u> • <u>Blue</u> • <u>White</u> • <u>Green</u> 				
	<p>6. What is SWL? Where do you find this?</p> <ul style="list-style-type: none"> • <u>Save working load. At container, Lubricator. Skid, bop skid, wireline units, hyd. Mast and etc</u> 				

	7. What is MPI? And load test date validity for a container, lub skid, and wireline unit <ul style="list-style-type: none"> • <u>MPI is magnetic process inspection. Load test validity for: - container (12 monthly), Lubricator skid (6 monthly), wireline units (12 monthly).</u> 				
	8. How long is the validity test date for Equipment passport and if you find one expired offshore what is your next course of action <ul style="list-style-type: none"> • <u>The validity test date for equipment passport is 3 month validity period, the OIM should ensure that the equipment is checked at least once a month and is still in good operating condition.</u> 				
Form C.5	PERFORM PROBLEM TROUBLESHOOTING AND REPORT				
	1. Why do you report for any abnormalities observed during wireline operation? <ul style="list-style-type: none"> • <u>It's important to report any abnormalities observed during operation to prevent unsmooth operation and to prevent any problems occur. It is also the key to proactive maintenance.</u> 				

	<p>2. List the daily prestart check point?</p> <ul style="list-style-type: none"> • Power pack <ul style="list-style-type: none"> ➢ <u>Check hydraulic tank suction line ball valve is fully open.</u> ➢ <u>Check hydraulic oil level in hydraulic tank is up to min level if less top-up.</u> ➢ <u>Check diesel level in diesel tank if less top-up.</u> ➢ <u>Check engine oil level.</u> ➢ <u>Check Air inlet /outlet and exhaust are not blocked.</u> ➢ <u>Check engine fan belt and guards.</u> ➢ <u>Check exhaust Flame trap is fitted in exhaust heat exchanger after cleaning.</u> ➢ <u>Engine cranking is done with the help of hydraulic starter.</u> ➢ <u>Check accumulator pressure should be greater than 2500 Psi.</u> ➢ <u>Check all hydraulic quick connectors for winch and BOP is connected properly.</u> ➢ <u>Check radiator coolant level.</u> • Reel Skid Unit <ul style="list-style-type: none"> ➢ <u>Check drum direction control valve is in Neutral or center position.</u> ➢ <u>Connect all hydraulic communication hoses.</u> ➢ <u>Check system pressure panel mounted rotary knob is in fully open position.</u> ➢ <u>Check wireline is properly connected with the Measuring Head Assembly.</u> ➢ <u>Check oil level in the lubricator tank.</u> ➢ <u>Check weight indicator hose, bleed the air and fill with fluid.</u> ➢ <u>Check 4-speed gearbox in neutral position.</u> ➢ <u>Ensure that the drum hand brake is applied.</u> ➢ <u>Check winch unit is properly locked with the deck.</u> 				
	<p>3. If the diesel engine will not start what 2 things should you check point?</p> <ul style="list-style-type: none"> • <u>Top up the diesel fuel</u> • <u>Bleed off air trap from the injector pump / diesel line system.</u> 				
	<p>4. If the engine run out of diesel, what must you do to restart?</p> <ul style="list-style-type: none"> • <u>Report the problem to supervisor onsite</u> • <u>Report to FSM, MS, Om</u> • <u>Make the problem report ASAP and send to FSM, Maintenance supervisor and OM</u> 				
	<p>5. Why do you report for each break down of particular equipment?</p> <ul style="list-style-type: none"> • <u>Reporting each break down of particular equipment is the key to proactive maintenance.</u> 				

	<p>6. How do you carry out trouble shooting of equipment?</p> <ul style="list-style-type: none"> • <u>To study the specification and design and find out the history of the equipment.</u> • <u>To take a photograph if found any physical damage.</u> • <u>To report all physical observation.</u> • <u>If applicable to simulate equipment on how they function and report your observation.</u> • <u>To disassemble and report any abnormalities on every equipment.</u> 				
--	--------------------------------------------------------------------------------------------------------------------------------------------------------------------------------------------------------------------------------------------------------------------------------------------------------------------------------------------------------------------------------------------------------------------------------------------------------------------------------------------------------------------------------	--	--	--	--

Assessed By:		Verified By	
Name		Name	
Position		Position	
Date		Date	

