

TSA THEORETICAL ASSESSMENT

By MUHAMMAD AQISH BIN ZAINUDIN

Basic of Wireline – Equipment & Operation

01

**Slickline
Introduction**

02

Basic Safety

03

**Pressure
Control
Equipment**

04

**Surface
Equipment**

05

**Downhole
Equipment**

06

Safety Sharing

01

**Slickline
Introduction**

What is Slickline?

- ❑ Slickline refers to a single strand wire which is used to run tools into wellbore for several purposes .

Drift/Tubing Clearance	Fishing
Zone Change Job (Open & Close SSD)	Plug Setting & Retrievable
Gas Lift Job (Retrieve & Set GLOV/GLV/Dummy)	Slickline Perforation
Tubing Integrity Test	Data Acquisition Job (SGS, FGS & PBU)
Sand Bailing	Wax Cutting

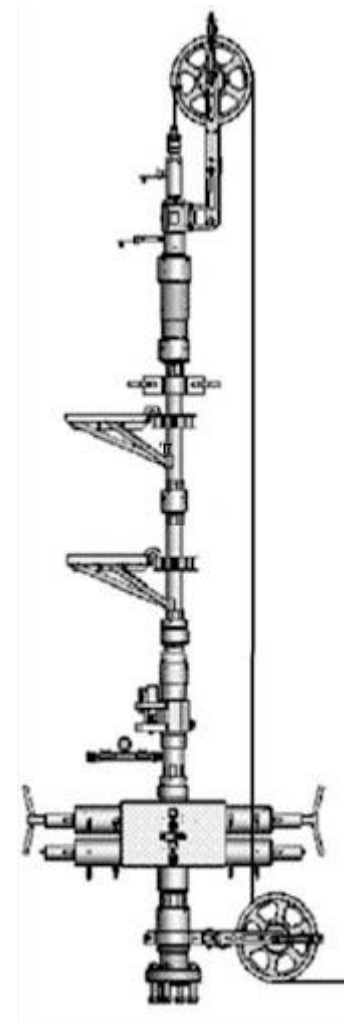

Slickline operation involve the manipulation of a basic slickline tool string and a specific tool in a well from the surface

02

**Basic
Safety**

SAFETY POLICY FOR DIMENSION BID



- Driving Policy
- Drug and Alcohol Policy
- Harassment in the workplace Policy
- HSSE Policy
- Smoking and Vaping policy
- PPE Policy
- Stop Work Policy

PERSONAL PROTECTIVE EQUIPMENT(PPE)



- Coverall
- Safety gloves
- Safety boots
- Safety hat
- Safety glasses
- Ear plug/ ear muff
- Safety Harness
- Respiratory protection

To minimize exposure to hazards that cause injuries and illnesses.
As a last barrier protection at workplace.

HIERARCHY OF CONTROL

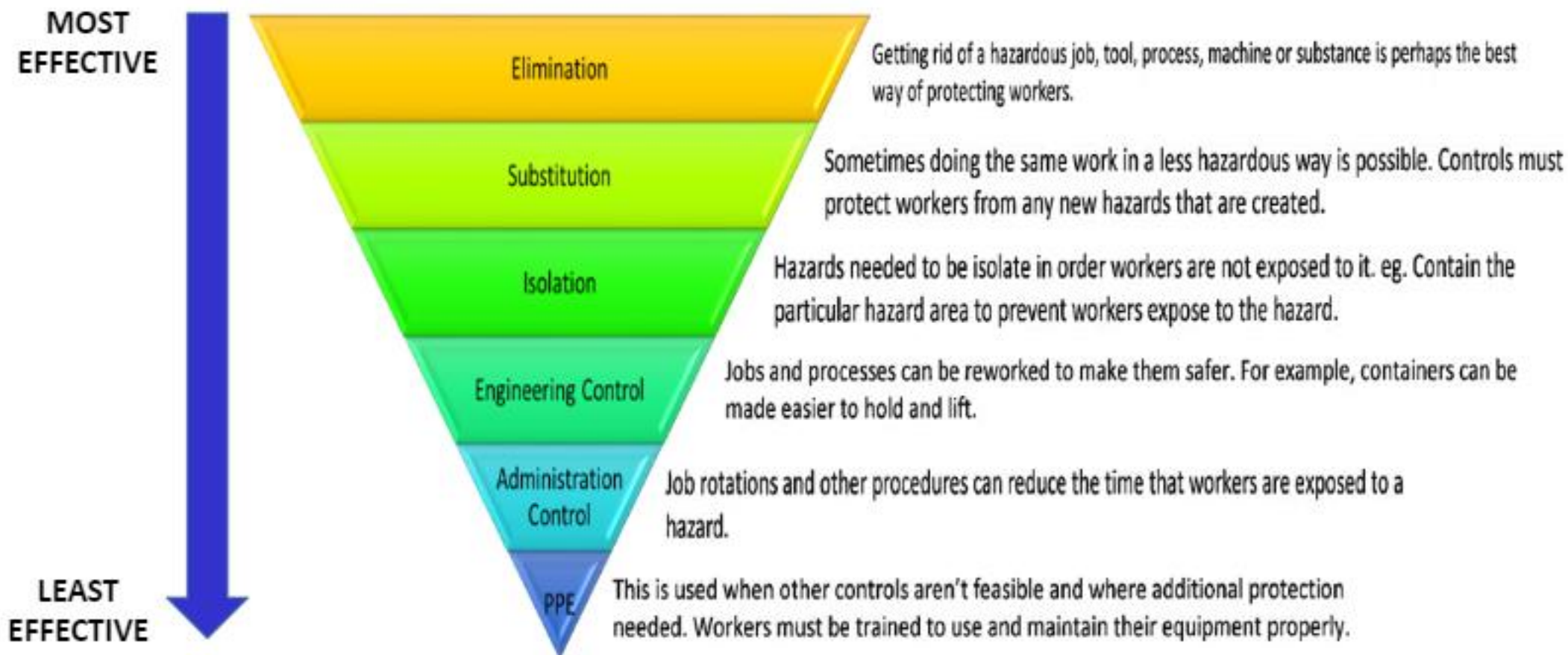

HAZARD HUNT

ALSO KNOWN AS ACT CARD / UCUA.

- TO INSPECT ALL OUR FACILITIES AND LOCATION FOR ANY UNSAFE ACT/CONDITION HAZARD AND TO TAKE ACTION WHERE CONTROL MEASURES NEED TO BE IMPROVED.

ALL EMPLOYEES ARE REQUIRED TO IMMEDIATELY REPORT ALL UNSAFE PERFORMANCE WHICH CAN LEAD TO HAZARD TO SUPERVISOR OR LOCATION HSSE OFFICER.



03

Pressure Control Equipment

PRESSURE CONTROL EQUIPMENT CONFIGURATIONS

- Quick Union
- Stuffing Box
- Lubricator
- Quick Test Sub
- Blow Out Preventer
- Pump In Tee
- Ball Valve
- Wellhead Cross Over
- Low Torque Valve
- Control Panel
- Pressure Test Unit

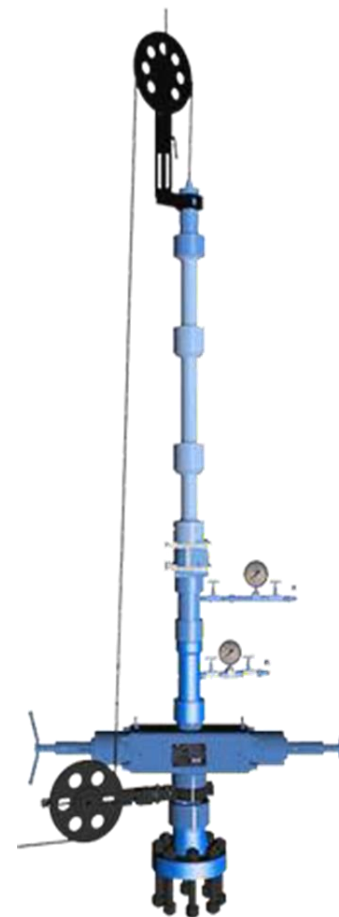

QUICK UNION

- ❑ Otis type connection - 45° angle.
- ❑ Bowen type connection - 90° angle
- ❑ Difference between Otis and Bowen are external holes, internal angle and pin diameter (Otis 3.5") (Bowen 4.375").

Usually we use :

- ❑ 3" ID
- ❑ 5-4 ACME
- ❑ 5" Thread Size
- ❑ 4 Thread Per Inch
- ❑ 5000 psi Working Pressure

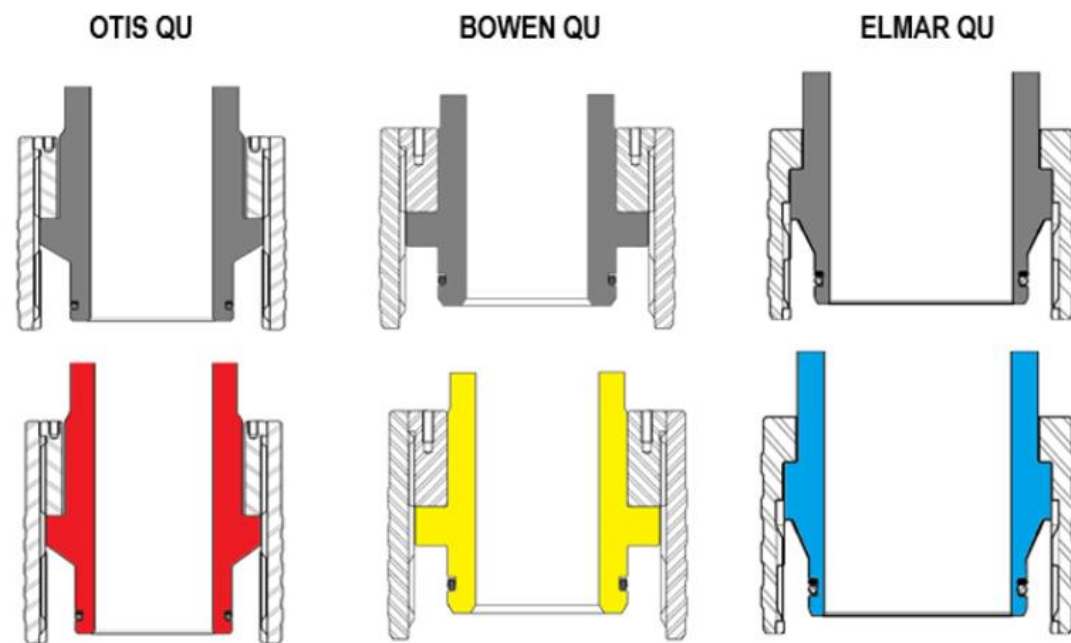

STUFFING BOX



- Primary barrier
- Contain the well pressure when slickline is moving or in stationary position
- Can be operated by hand pump manually
- Sheave diameter available are 16", 18" and 20" (1:120).
- Guide the wire from bottom hay pulley into top of the lubricator that being rig up
- Brass** internal components that can prevent slickline wire from damage
- Working pressure – 5000psi to 15000psi

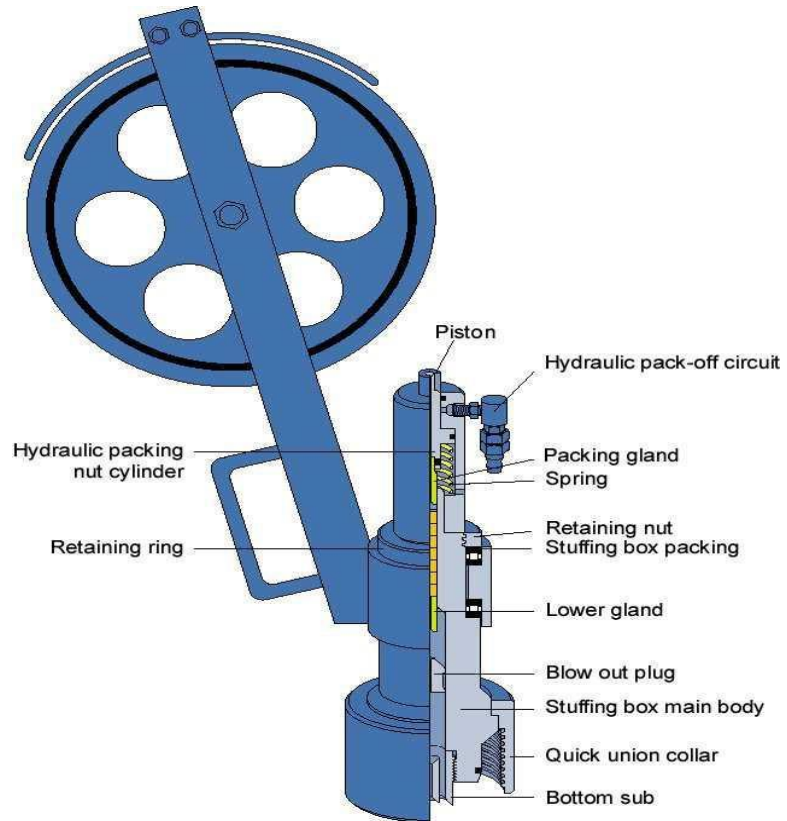

LUBRICATOR



- To provide space for the tool to be contained in under pressure when opening and closing the wellhead
- Non-ported and ported
- Length available 8 ft, 4 ft
- 2ft, 3ft (we call it PUP joint)
- Length of the lubricator depends on the tool string used
- The longer the downhole tools, the more lubricator needed.

Working Pressure (WP) psi *	Test Pressure (TP) psi
3,000	4,500
5,000	7,500
10,000	15,000
15,000	22,500

QUICK TEST SUB



- ❑ Makes it easy to change toolstring during multiple run
- ❑ Placed at “break point” below lubricator and above BOP.
- ❑ Can be pressure test using hand pump

BLOWOUT PREVENTER



- ❑ To seal the line/ensure pressure to be isolated without cutting the wire
- ❑ Secondary barrier
- ❑ Operated by hydraulic or manually
- ❑ Hold pressure from below
- ❑ Mechanically and hydraulically to close the rams
- ❑ Each arm has fittings for hydraulic
- ❑ Size: 3", 4" and 7"

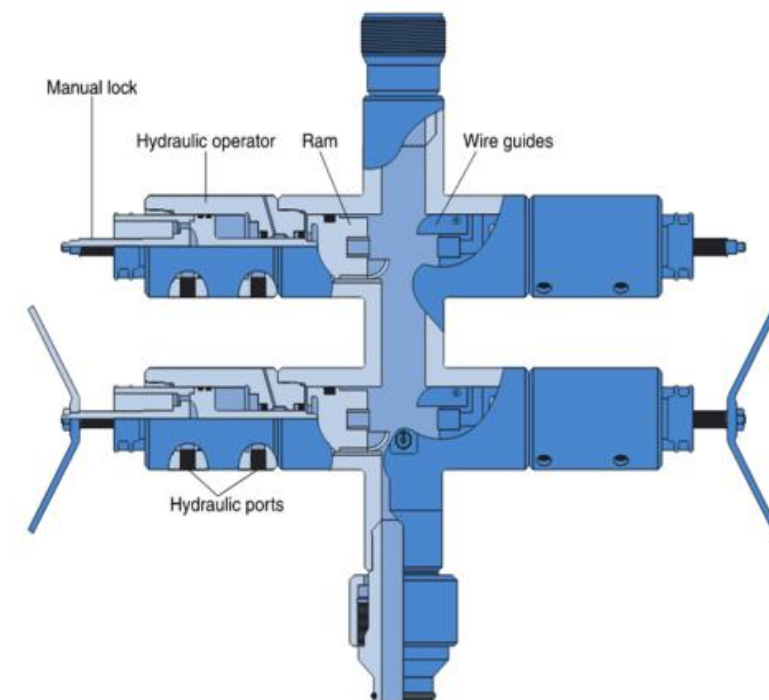
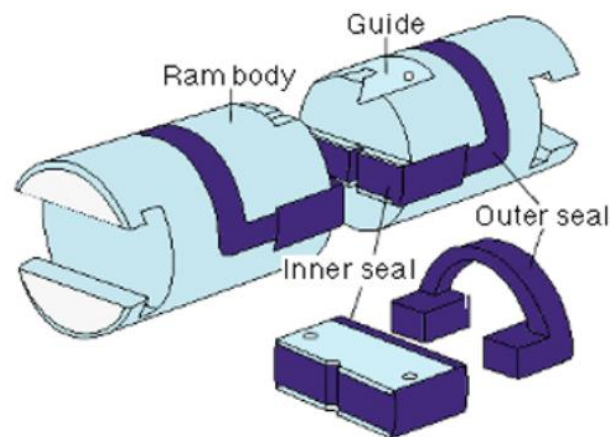

BALL VALVE



- Operated hydraulically and manual
- Ball valves are capable to cut wire
- Hold pressure from above and below (additional wellhead valve)
- Use for pressure test PCE

PUMP IN TEE



- Use for chemical injection point
- It is normally positioned below the BOP and above wellhead
- Specially design pumping tee, with different top and bottom unions are use as wellhead adapted crossover

LOW TORQUE VALVE



- ❑ Also known as plug valve
- ❑ To control the fluid flow by rotating the handle (opening or closing)
- ❑ Valve requires a quarter turn (90 degree) using a bar

CROSSOVER



- ❑ To provide transition between different size of threads and otherwise incompatible unions made by same or different manufactures
- ❑ Designed with Union Box Up and Union Pin & Collar Down

CONTROL PANEL

❑ CONTROL PANEL (CP)

To operate BOP rams

❑ SINGLE WELL CONTROL PANEL (SWCP)

To operate MV and SCSSV

❑ WELL CONTROL PANEL (WCP)

An integrated CP can operate BOP, STUFFING BOX, MV and SCSSV

AIR SUPPLY:

Min – 75 psi

Max – 120 psi

Standard - 100 to 110 psi



PRESSURE TEST UNIT (PTU)

- ❑ To pump fluid or pressure test the PCE component
- ❑ Fast filling and high pressure pump for testing up to a maximum **15 000 psi**.
- ❑ The test result is recorded on chart recorder.
- ❑ Suitable to use with water/soluble oil or glycol.



04

**Surface
Equipment**

SURFACE EQUIPMENT CONFIGURATION

POWER PACK
REEL SKID UNIT
HAY PULLEY
WIRE TESTER
WEIGHT INDICATOR
ODOMETER
WIRELINE MAST
COMPRESSOR

HAZARDOUS AREA

Zone 0	Explosive atmosphere is CONTINUOUSLY present
Zone 1	Explosive atmosphere is OFTEN present
Zone 2	Explosive atmosphere is ACCIDENTALLY present

POWER PACK

- Diesel driven
- 80 horse power
- To supply hydraulic power for wireline mast and RSU
- Spring and hydraulic starter for diesel powered hydraulic system
- Open loop and close loop
- Zone 2 certified equipment

Safety shutdown system	Set at
Overspeed shutdown	2200 rpm
Low engine oil pressure	15 PSI
High coolant temperature	99 deg Celsius
High exhaust temperature	200 deg Celsius



POWER PACK

- ❑ Before starting procedure
 - Check hydraulic tank suction line ball valve is fully open
 - Check hydraulic oil level
 - Check diesel oil level
 - Check engine oil level
 - Check radiator coolant
 - Check air inlet/outlet and exhaust are not blocked
 - Check engine fan belt and guards
 - Check exhaust flametrap is fitted in exhaust heat exchanger
 - Check accumulator pressure, should be greater than 2500psi
 - Check every connections



REEL SKID UNIT

- Known as winch or wireline unit
- Available with single or double drum
- 4 speed gear
- Lowering and rising toolstring during operation
- Max working pressure 2200psi – 2500psi
- Wire tension should be 300lbs to 400lbs



REEL SKID UNIT

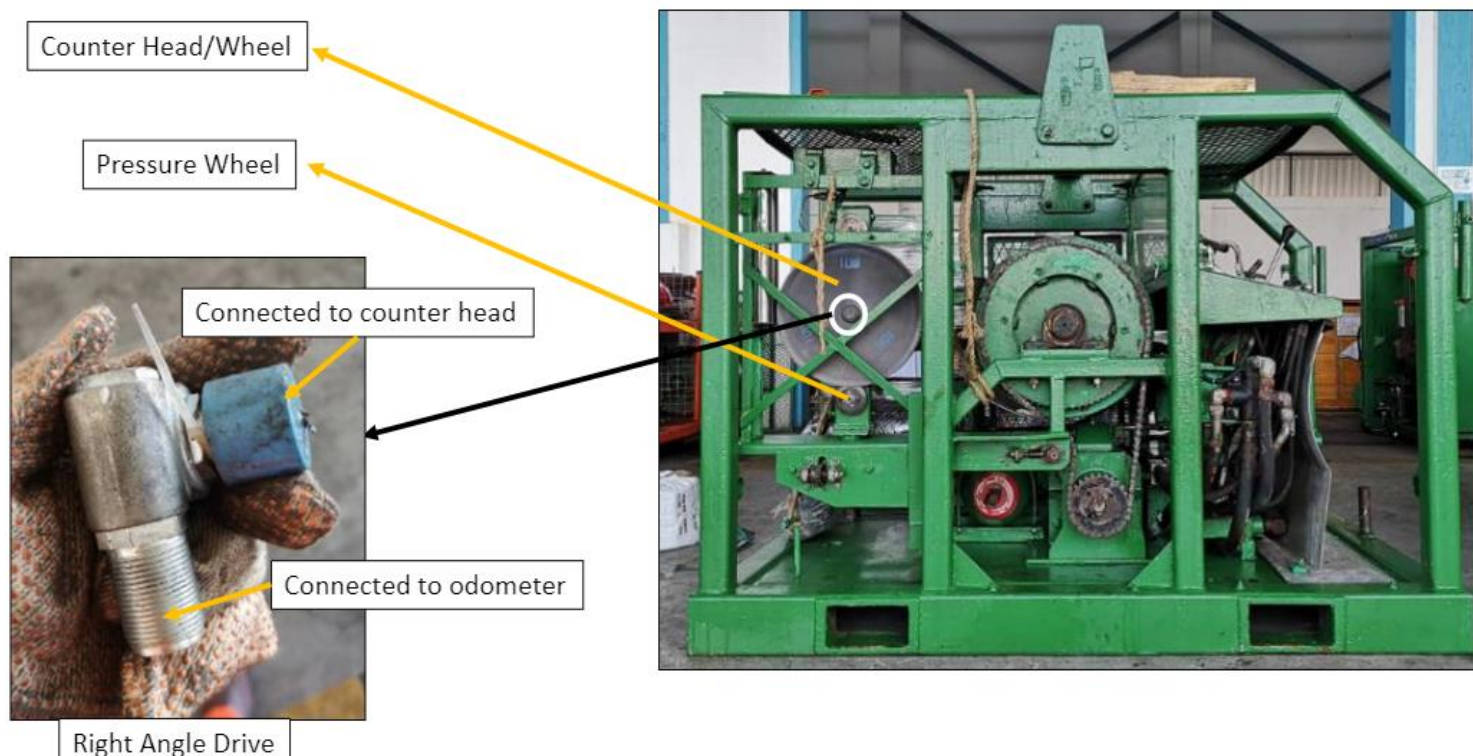

- ❑ Pre-operational check
 - Ensure the gear is in NEUTRAL or drum can spin as the engine starts, prevent from creating a 'bird nest'
 - The handbrake is ON
 - Check the drive chain tension- adjust as necessary

REEL SKID UNIT (COUNTER WHEEL ASSEMBLY)

- ❑ Accurately displays the depth of wireline tools, as they run into the well.
- ❑ Available to read meters of feet.
- ❑ The counter wheel can vary size from 8ins diameter to 16 ins diameter
- ❑ Wire/pulley ratio:
OD of wire X 120 = correct pulley size

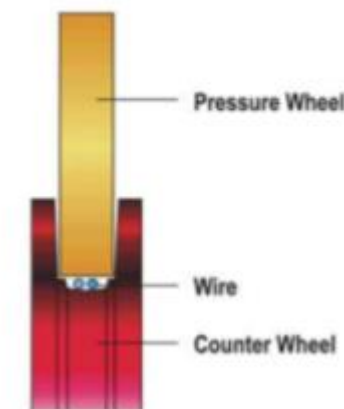
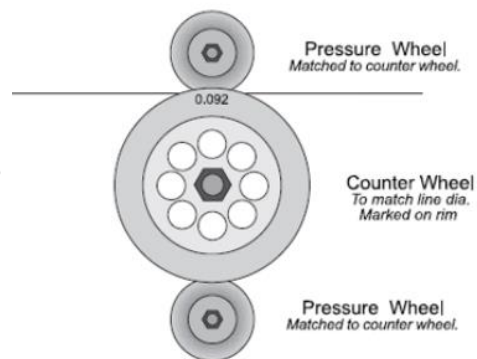

- ❑ Prevent the wire from springing out of counter wheel
- ❑ Should ride ABOVE the wire, and should not actually be in contact with it.

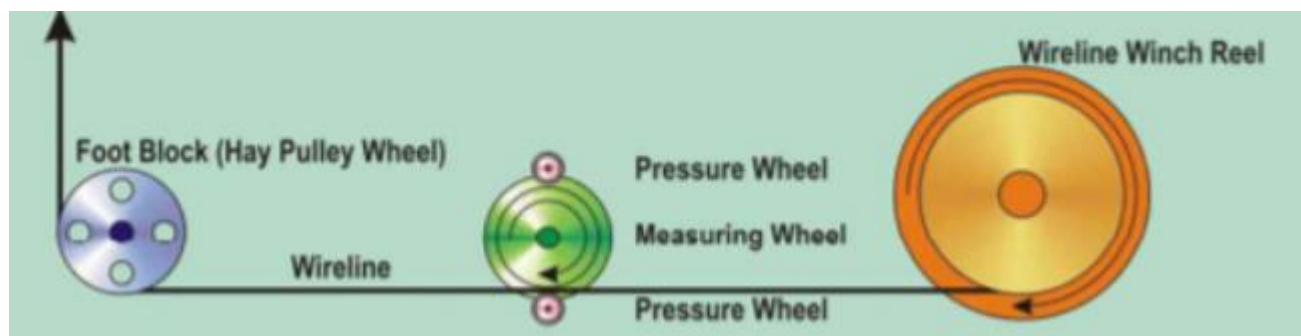

REEL SKID UNIT (ODOMETER)

- ❑ Also known as **depth counter / depth measuring device**
- ❑ Use for measuring depth of slickline toolstring hanging in a tubing string
- ❑ Zero and start reading from tubing hanger.

- ❑ Drum rotation:
 - Reel rotated **forward** – wire into well & **depth increase**
 - Reel rotated **backward** – wire out of well & **depth decrease**



- ❑ Mechanical right angel drive
 - Measures in feet unit
 - Converts the measuring wheel rotation to depth units

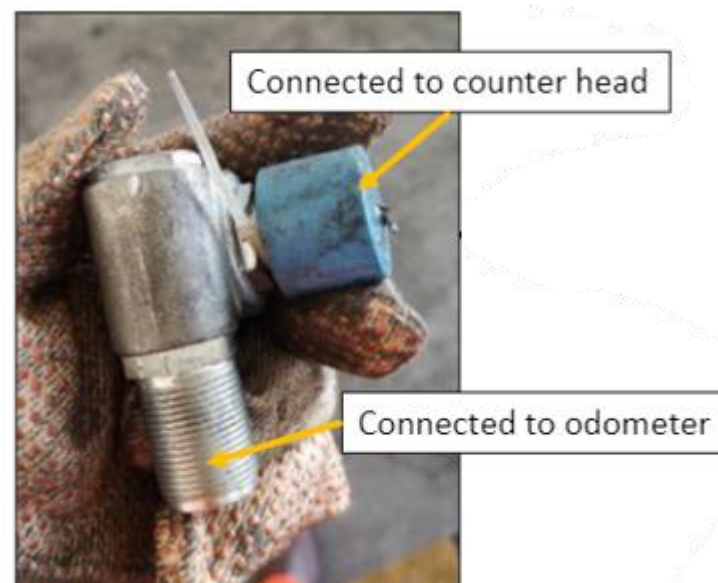

WEIGHT INDICATOR



- ❑ To determine the total weight of tools hung in tubing string
- ❑ Available in 2000lbs, 4000lbs and 5000lbs

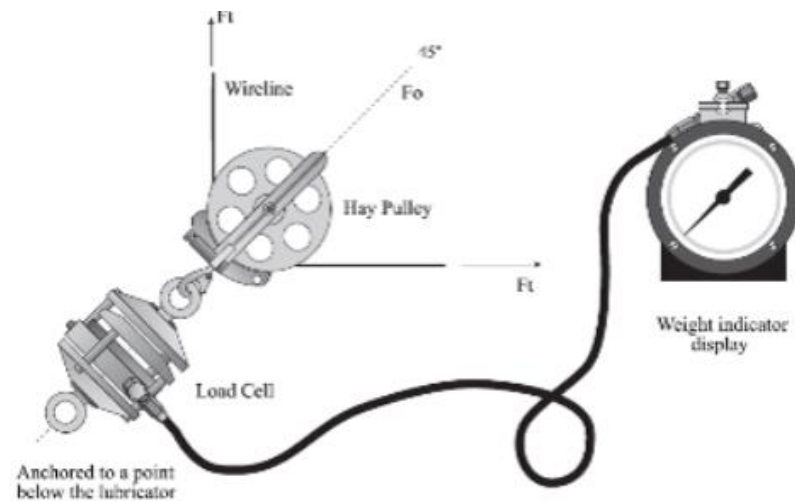

YA-2 Pump



HAY PULLEY

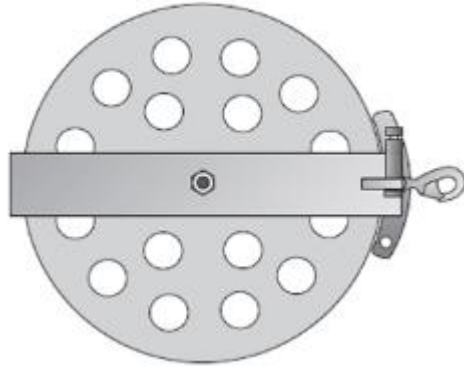

- To bring wireline down from stuffing box and into horizontal to the wireline winch drum
- The wire should form 90 degree angle at the pulley
- Important to provide an accurate reading of line tension on the weight indicator
- Hooked directly on the eye of weight indicator/load cell
- Size (7,13,14,15,16,20) inch

WIRE TESTER – TENSILE TESTING

- ❑ To determine condition of the wire – fatigue rating
- ❑ Result will be recorded on chart recorder (K-Rec chart) in LBS

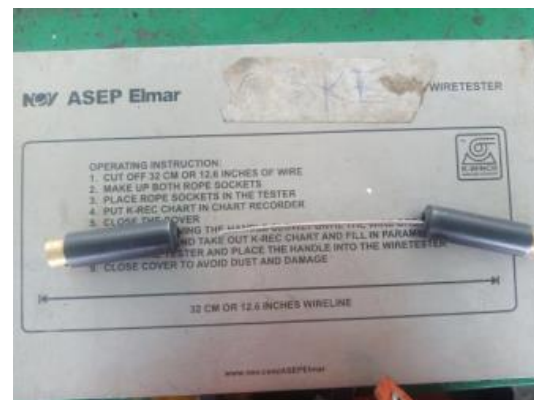

ZERON STAINLESS STEEL WIRE

Diameter (Inch)	Minimum Breaking Load (lbs)	Minimum Torsion	Safe Working Pressure@60%
0.092"	1920	4	1152
0.108"	2500	3	1500
0.125"	3300	2	1980
0.140"	4050	2	2430

WIRELINE MAST

- ❑ To hold and lift the lubricator so that it is in the upright condition during slickline operation (rig up).
- ❑ Available in 30ft, 40ft, 70ft
- ❑ 70ft zone 1
- ❑ Capability of weight for 40ft (1.5ton)



AIR COMPRESSOR

- To supply air pressure for SWCP, CP, WCP
- Spring starter
- Use diesel engine to produce power
- Zone 2 certified
- Air supply is 100 to 130 psi



05

**Downhole
Equipment**

BASIC TOOLSTRING CONFIGURATION

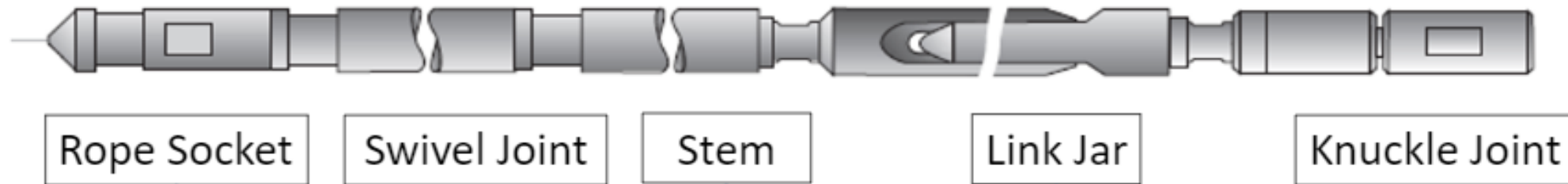

DOWNHOLE TOOLS CONNECTION

- Sucker Rod
- Quick Lock System (QLS)
- Quick Release Joint (QRJ)
- Trinity



SUCKER ROD



QUICK LOCK



QLS

Trinity

HD-QRJ

DOWNHOLE TOOLS CONNECTION

Connection sizes:

Sucker Rod

1. 15/16
2. 1 1/16
3. 1 9/16

Quick Lock System

1. 1 ½
2. 1 7/8
3. 2 ½

Shear pin sizes:

- 1/8
- 3/16
- 1/4
- 5/16
- 3/8

Shear pin types:

- Brass
- Stainless Steel
- Aluminium

ROPE SOCKET

❑ Used as a method of connecting the slickline wire to the tool string, from wire size from 0.108", 0.125" and 0.140"

❑ 3 types of rope socket

- Pear drop type
- Spring and disc type
- Braided clamp type

❑ TUBING – RS SIZE

3 ½ - 1 7/8

2 7/8 - 1 ½

2 3/8 - 1 1/4



Spring and
Disc Type



Pear Drop
Wedge Type



Braided Clamp
Type

SWIVEL JOINT

- ❑ Swivel joint is a wireline accessory used to minimize the effect of the wire twist caused by subsurface devices being run
- ❑ The swivel joint has a double fish neck
- ❑ Sideways movement of swivel varies from 1.5 to 5 degree. So, its not suitable to be used as knuckle joint which has 15 degree of movement.



SWIVEL JOINT WITH QLS CONNECTION

STEM

- ❑ It is known as weight bar/sinker bar
- ❑ To provide the weight of the toolstring
- ❑ Also giving a weight impact while jarring operation
- ❑ Available in 2ft, 3ft and 5ft
- ❑ Types of stem:
 - Roller stem (for deviated wells)
 - Lead filled stem
 - Tungsten stem (heaviest)
 - Normal stem



ROLLER STEM



TUNGSTEN STEM

STEM

- ❑ Weight of **NORMAL STEM** calculation

$$\text{OD}^2 \text{ (INCH)} \times 8/3 = \text{WEIGHT LB/FT}$$

OD (inch)	Weight lb/ft	Fishing Neck
1	2.5lbs	0.875"
1.1/4	4.2lbs	1.187"
1.1/2	6.0lbs	1.375"
1.7/8	9.4lbs	1.750"
2.1/8	12lbs	1.750"
2.1/2	16.7lbs	2.313"

LINK JAR

- ❑ It is also known as spang jar / mechanical jar
- ❑ Designed to act like a sliding hammer by utilizing the weight of the stem bars to convey a powerful jarring action
- ❑ Available with 20" and 30" stroke
- ❑ Other types of jar"
 - Hydraulic jar
 - Tubular jar
 - Spring jar
 - Upstroke jar

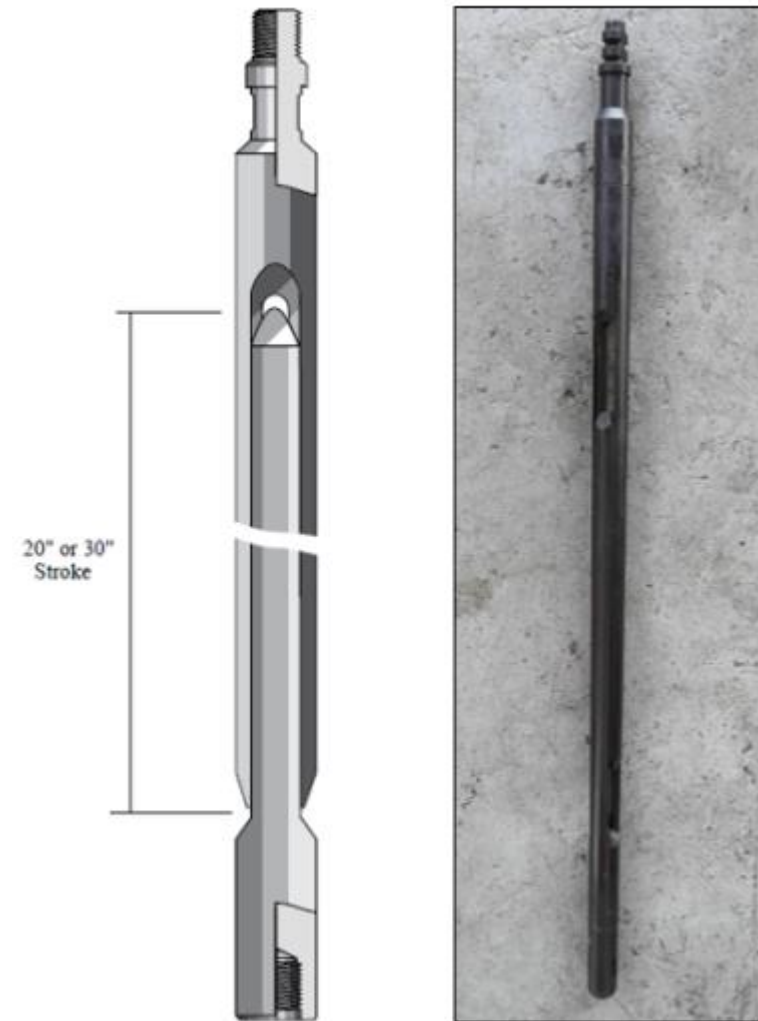

KNUCKLE JOINT

- ❑ Knuckle joints are used to add flexibility within the toolstring and particularly effective within deviated well bores
- ❑ 15 degree angle movement

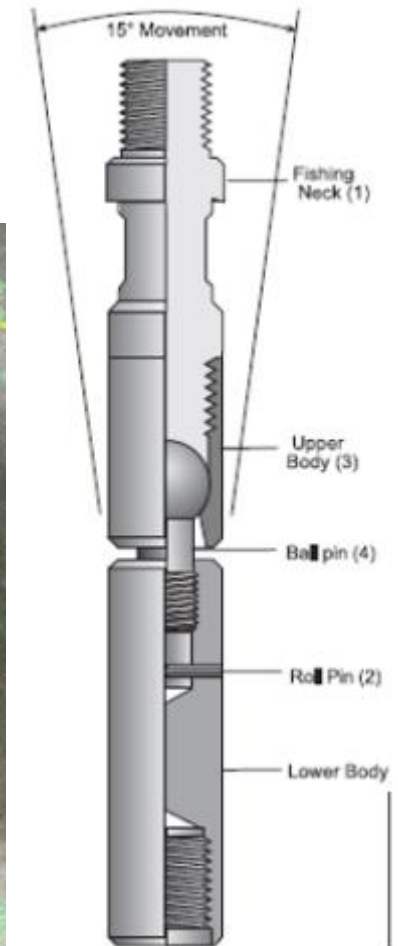

FISHING NECK DIMENSION

☐ EXTERNAL FISHING NECK (INCH)

Nominal tool size	Fish Neck (SRT)
1"	1.000"
1 1/4"	1.187"
1 1/2"	1.375"
1 7/8"	1.750"
2 1/8"	1.750"
2 1/2"	2.313"

06

**Safety
Sharing**

PROPER MANUAL HANDLING - TEAM

- ❑ Team/buddy lifting
- ❑ Prevent from back injuries



Thank
you.

