

# DIMENSION BID



---

## ANGSI A-25 SAND CLEANOUT & RE-PERFORATION

---

Revision: 0  
Prepared for: Nik M Qusyairi B. M Zulkifli  
Date Prepared: 20<sup>th</sup> July 2023  
Well: A-25  
Field: ANGSI  
Operation Region: PMA  
Prepared by: Muhd Shahfariz / Muhammad Hafiz  
Phone: +6012-5407323  
Email: shahfariz@neudimension.com

<b>DIMENSION BID</b>	DIMENSION BID COILED TUBING SERVICES		
	ANGSI A-25	SAND CLEANOUT & RE- PERFORATION	

## DESIGN VERIFICATION

**PREPARED BY DB**

CTS Field Engineer

\_\_\_\_\_  
Muhammad Shahfariz / Muhammad Hafiz

20/7/2023

\_\_\_\_\_  
Date

**REVIEWED BY DB**

CTS Technical Advisor

\_\_\_\_\_  
Kung Yee Han

\_\_\_\_\_  
Date

**APPROVED BY DB**

CTS Operation Manager

\_\_\_\_\_  
Aliff Amirul Adenan

\_\_\_\_\_  
Date

**APPROVED BY PCSB**

Angsi  
Well Intervention Engineer

\_\_\_\_\_  
Nik M Qusyairi B. M Zulkifli

\_\_\_\_\_  
Date

**APPROVED BY PCSB**

Technical Professional  
Well Intervention, PMA

\_\_\_\_\_  
M Izwan B A Jalil

\_\_\_\_\_  
Date

**APPROVED BY PCSB**

Head of Cluster 1  
Well Intervention, PMA

\_\_\_\_\_  
Ahmad Hafizi B Ahmad Zaini

\_\_\_\_\_  
Date

**Remark: Do not execute the procedures in this document if it is not fully approved and signed by all parties.**

Prepared By: Muhd Shahfariz	Reviewed By: Kung Yee Han	Date: 20/6/2023	Rev. Rev.0	Controlled Document DB-CT-MSF-23011	Pg. 2
--------------------------------	------------------------------	--------------------	---------------	----------------------------------------	----------

<b>DIMENSION BID</b>	<b>DIMENSION BID COILED TUBING SERVICES</b>		
	ANGSI A-25	SAND CLEANOUT & RE- PERFORATION	

## DISTRIBUTION LIST

No	Personnel	Company	Name	Email
1	Well Intervention Engineer	PCSB	Nik M Qusyairi B. M Zulkifli	qusyairi.zulkifli@petronas.com
2	Well Service Supervisor (WSS)	PCSB	TBA	TBA
3	Offshore Installation Manager (OIM)	PCSB	TBA	TBA
4	Production Technologist	PCSB	TBA	TBA
5	Cluster Head	PCSB	Ahmad Hafizi B. Ahmad Zaini	hafizi.zaini@petronas.com
6	Head of well Intervention	PCSB	Eddy B Samaile	eddysamaile@petronas.com
7	Material Coordinator (Logistics)	DB – Kemaman	Marzokey	marzokey@neudimension.com
8	Service Supervisor	DB – Kemaman	TBA	TBA
9	Field Engineer Coiled Tubing Services	DB – Kemaman	Shahfariz / Hafiz	hafiz.saharuddin@neudimension.com
10	Operation Engineer Coiled Tubing Services	DB – Kemaman	Mohammad Faizal Ali	faizal.ali@neudimension.com
11	Technical Advisor Coiled Tubing Services	DB – Kemaman	Kung Yee Han	yeehan.kung@neudimension.com
12	Operation Manager Coiled Tubing Services	DB – Kemaman	Aliff Amirul Adenan	aliff.adenan@neudimension.com
13	Field Service Manager Coiled Tubing Services	DB – Kemaman	Mohd Khairul Ridhwan	khairul.ridhwan@neudimension.com
14	HSE Supervisor	DB – Kemaman	Ahmad	ahmad@neudimension.com

Prepared By: Muhd Shahfariz	Reviewed By: Kung Yee Han	Date: 20/6/2023	Rev. Rev.0	Controlled Document DB-CT-MSF-23011	Pg. 3
--------------------------------	------------------------------	--------------------	---------------	----------------------------------------	----------

<b>DIMENSION BID</b>	DIMENSION BID COILED TUBING SERVICES		
	ANGSI A-25	SAND CLEANOUT & RE- PERFORATION	

## PERSONNEL CONTACT

Any means of following doubt / unusual parameters / Emergency, please contact Dimension Bid personnel in onshore immediately.

No	Name	Position	Company	Location	Contact No
1	Aliff Amirul Adenan	Operation Manager	DB	Kemaman	011 – 1225 7044
2	Mohd Khairul Ridhwan	Field Services Manager	DB	Kemaman	014 – 515 4452
3	Kung Yee Han	Technical Advisor	DB	Kemaman	011 – 612 05611
4	Mohammad Faizal Ali	Operation Engineer	DB	Kemaman	013 – 736 1046

## REVISION HISTORY

Rev. No	Section	Date	Revised By
0	All	20/6/2023	Muhd Shahfariz Muhammad Hafiz

## ACRONYM

Acronym	Abbreviation
BHA	Bottom Hole Assembly
RIH	Run In Hole
POOH	Pull Out Of Hole
HUD	Hang Up Depth
TCC	Tubing Clearance Check
ZSO	Zone Shut Off
SCO	Sand Clean Out
TIT	Tubing Integrity Test
BOP	Blow Out Preventer
CT	Coil Tubing

ID	Internal Diameter
MDTHF	Measure Depth Tubing Head Flange
SSD	Sliding Side Door
P&A	Plug and Abandonment
MASTP	Maximum Allowable Surface Treating Pressure
STP	Surface Treating Pressure

Prepared By: Muhd Shahfariz	Reviewed By: Kung Yee Han	Date: 20/6/2023	Rev. Rev.0	Controlled Document DB-CT-MSF-23011	Pg. 4
--------------------------------	------------------------------	--------------------	---------------	----------------------------------------	----------

<b>DIMENSION BID</b>	DIMENSION BID COILED TUBING SERVICES		
	ANGSI A-25	SAND CLEANOUT & RE- PERFORATION	

## TABLE OF CONTENT

.....	1
<b>DESIGN VERIFICATION</b> .....	2
<b>DISTRIBUTION LIST</b> .....	3
<b>REVISION HISTORY</b> .....	4
<b>ACRONYM</b> .....	4
<b>TABLE OF CONTENT</b> .....	5
<b>OBJECTIVES</b> .....	7
<b>BACKGROUND</b> .....	7
<b>WELL DATA</b> .....	7
<b>OPERATION SUMMARY</b> .....	8
<b>WELL DIAGRAM</b> .....	9
<b>WELL 3D PLOT</b> .....	10
<b>TREATMENT VOLUME</b> .....	11
<b>COILED TUBING STRING INFORMATION</b> .....	12
<b>CT STRING FATIGUE (Jason 683330)</b> .....	12
<b>CT STRING # 683330 LATEST PIPE MANAGEMENT</b> .....	13
<b>PROCESS FLOW DIAGRAM</b> .....	14
<b>SAFETY OPERATIONAL PROCEDURES</b> .....	15
<b>HEALTH, SAFETY &amp; ENVIRONMENT</b> .....	16
<b>EQUIPMENT RIG UP PROCEDURE</b> .....	17
<b>EQUIPMENT PRESSURE TESTING PROCEDURE</b> .....	19
<b>OPERATIONAL PROCEDURE</b> .....	20
<b>SLICKLINE OPERATION</b> .....	20
<b>COILED TUBING OPERATION – RUN#1 SAND CLEANOUT UNTIL 20m below bottom perforation I15U at depth 4,725m-MDDF</b> .....	21
<b>COILED TUBING OPERATION – RUN#2 GRCCCL c/w 2-3/8” Dummy Gun</b> .....	27
<b>COILED TUBING OPERATION – RUN#3 Re-perforation using 2-3/8” Spent Gun (10metre gun)</b> .....	32
<b>COILED TUBING OPERATION – RUN#4 Re-perforation using 2-3/8” Spent Gun (10metre gun)</b> .....	33
<b>COILED TUBING OPERATION – Contingency Unloading</b> .....	34
<b>APPENDIX I – BOTTOM HOLE ASSEMBLY SCHEMATIC</b> .....	37
<b>APPENDIX III – ORPHEUS SIMULATIONS &amp; CIRCA SIMULATION</b> .....	43
<b>APPENDIX IV – EMERGENCY PROCEDURE</b> .....	49
<b>EMERGENCY BOP OPERATIONS</b> .....	49

Prepared By: Muhd Shahfariz	Reviewed By: Kung Yee Han	Date: 20/6/2023	Rev. Rev.0	Controlled Document DB-CT-MSF-23011	Pg. 5
--------------------------------	------------------------------	--------------------	---------------	----------------------------------------	----------

<b>DIMENSION BID</b>	DIMENSION BID COILED TUBING SERVICES		
	ANGSI A-25	SAND CLEANOUT & RE- PERFORATION	

<b>LEAK IN COILED TUBING AT SURFACE .....</b>	<b>50</b>
<b>LEAK IN COILED TUBING BELOW SURFACE.....</b>	<b>50</b>
<b>LEAK IN SURFACE PRESSURE CONTROL EQUIPMENT .....</b>	<b>51</b>
<b>COILED TUBING RUNS AWAY INTO WELL .....</b>	<b>52</b>
<b>COILED TUBING IS PULLED OUT OF STUFFING BOX .....</b>	<b>53</b>
<b>COILED TUBING COLLAPSED AT SURFACE.....</b>	<b>53</b>
<b>COILED TUBING BREAKS AT SURFACE .....</b>	<b>54</b>
<b>BUCKLED TUBING.....</b>	<b>54</b>
<b>COILED TUBING STUCK IN HOLE PROCEDURES.....</b>	<b>56</b>
<b>STUCK CT COIL RECOVERY PROCESS.....</b>	<b>58</b>
<b>APPENDIX V – DECISION TREE (Run#1 SCO).....</b>	<b>59</b>
<b>DECISION TREE (Run#2 GRCCL).....</b>	<b>60</b>
<b>DECISION TREE (Run#3,4 Re-per 10meter Gun).....</b>	<b>61</b>
<b>DECISION TREE (Contingency Unloading).....</b>	<b>62</b>

<b>DIMENSION BID</b>	DIMENSION BID COILED TUBING SERVICES		
	ANGSI A-25	SAND CLEANOUT & RE- PERFORATION	

## OBJECTIVES

The objective of this job is:

1. To perform Coiled Tubing Sand Cleanout until 20m below bottom perf I15U at depth 4725m-MDDF
2. Perform re-perforation for I15U (4685 - 4705m MDDF)

## BACKGROUND

Angsi A-25 is a single string oil producer and was completed on Aug 2004. During last slickline TCC, slickline able to reached till 5m below EOT, concluding no HUD inside tubing. PCSB has engaging with DB to perform sand clean out from EOT until 20m below bottom perforation I15U at depth 4,725m-MDDF and re-perforation I15U using pressure deployment system.

## WELL DATA

Input Parameter	Parameter Value
Field	Angsi-A25
Max. Deviation (degrees)	78.46 Deg @ 3090m-MDDF
Min. Restriction (inch)	<b>2.69" @ 4672.2m-MDDF</b>
Tubing Specification	3-1/2" Production Tubing, 9.2# ppf,
Type of Fluid & Density	9.4 PPG NaCl (based on data in Well Diagram)
Top of Fluid	TBA
Current Well Status	Shut In
Fracture Gradient	0.7 psi/ft (assumed)

Prepared By: Muhd Shahfariz	Reviewed By: Kung Yee Han	Date: 20/6/2023	Rev. Rev.0	Controlled Document DB-CT-MSF-23011	Pg. 7
--------------------------------	------------------------------	--------------------	---------------	----------------------------------------	----------

<b>DIMENSION BID</b>	DIMENSION BID COILED TUBING SERVICES		
	ANGSI A-25	SAND CLEANOUT & RE- PERFORATION	

### OPERATION SUMMARY

<i>Item</i>	<i>Job Description</i>	<i>Remark</i>
A	Slickline	1. RIH for TCC
B	Coiled Tubing Operation	1. Run#1: Sand Cleanout until 20m below bottom perf I15U at depth 4,725m-MDDF 2. Run#2: GRCCL with Dummy 2-3/8" Spent Gun 3. Run#3: Re-perforation using 2-3/8" Gun (Deployment 10m gun) 4. Run#4: Re-perforation using 2-3/8" Gun (Deployment 10m gun) 5. Contingency Run#1: Nitrogen Unloading

Prepared By: Muhd Shahfariz	Reviewed By: Kung Yee Han	Date: 20/6/2023	Rev. Rev.0	Controlled Document DB-CT-MSF-23011	Pg. 8
--------------------------------	------------------------------	--------------------	---------------	----------------------------------------	----------



<b>DIMENSION BID</b>	<b>DIMENSION BID COILED TUBING SERVICES</b>		
	ANGSI A-25	SAND CLEANOUT & RE- PERFORATION	

**WELL 3D PLOT**

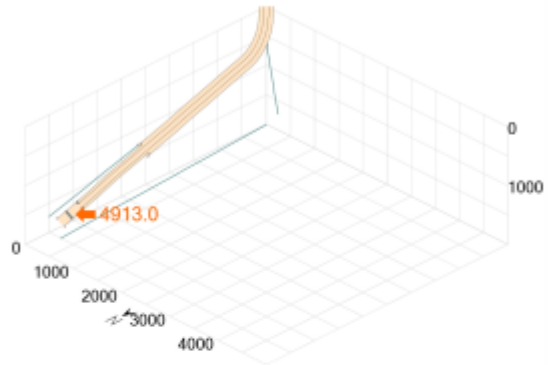
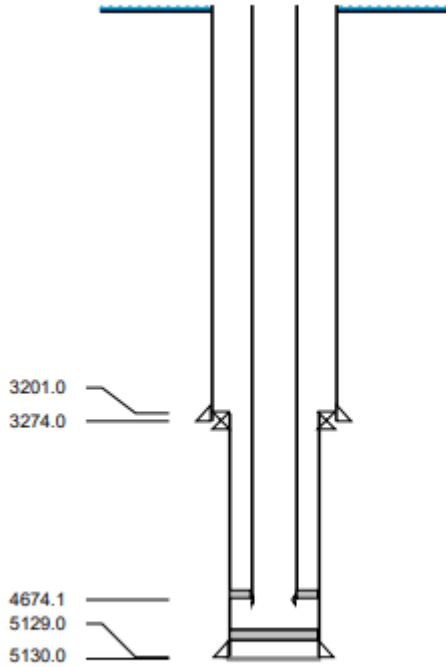

Well name: Angsi A-25  
 Total depth: 5130.0 m  
 Max Inclination: 78.8° at 3080.5 m  
 Max DLS: 3.929 °/100ft at 582.2 m  
 Min ID: 2.690 in at 4672.2 m  
 WHP: 150 psi

<i>Input Parameter</i>	<i>Parameter Value</i>
<b>Field</b>	Angsi A-25
<b>Max. Deviation (degrees)</b>	78.46 Deg @ 3090m-MDDF
<b>Min. Restriction (inch)</b>	2.69" XN-Nipple

<b>DIMENSION BID</b>	<b>DIMENSION BID COILED TUBING SERVICES</b>				
	ANGSI A-25		SAND CLEANOUT & RE- PERFORATION		

## TREATMENT VOLUME

Type	Tubing															Length ft	Total Volume (bbls)
	External Pipe			Internal Pipe			Internal Pipe			Caps	From	To	From	To			
	OD (inch)	ID (inch)	W(lb/ft)	OD (inch)	ID (inch)	W(lb/ft)	OD (inch)	ID (inch)	W(lb/ft)	Barrel/lin (ft)	m	m	ft	ft			
THF to EOT	3 1/2	2.992	9.2							0.00870	16.98	4674.10	56	15336	<b>15280</b>	<b>132.9</b>	
<b>TOTAL</b>																<b>133</b>	

Type	A-Annulus (PCP)															Length ft	Total Volume (bbls)
	External Pipe			Internal Pipe			Internal Pipe			Caps	From	To	From	To			
	OD (inch)	ID (inch)	W(lb/ft)	OD (inch)	ID (inch)	W(lb/ft)	OD (inch)	ID (inch)	W(lb/ft)	Barrel/lin (ft)	m	m	ft	ft			
THF to 7" Liner Top	9 5/8	8.535	53.5	3 1/2	2.992	9.2				0.05886	16.98	3201.00	56	10502	<b>10447</b>	<b>614.9</b>	
7" Liner Top to Packer #1	7	6.366		3 1/2	2.992	9.2				0.02747	3201.00	4665.00	10502	15306	<b>4803</b>	<b>131.9</b>	
<b>TOTAL</b>																<b>747</b>	

Type	Wellbore Area on I15U Reservoir															Length ft	Total Volume (bbls)
	External Pipe			Internal Pipe			Internal Pipe			Caps	From	To	From	To			
	OD (inch)	ID (inch)	W(lb/ft)	OD (inch)	ID (inch)	W(lb/ft)	OD (inch)	ID (inch)	W(lb/ft)	Barrel/lin (ft)	m	m	ft	ft			
Packer #1 to EOT	7	6.366		3 1/2	2.992	9.2				0.02747	4665.00	4674.10	15306	15336	<b>30</b>	<b>0.8</b>	
EOT to Top of Cement	7	6.366								0.03937	4674.10	4913.00	15336	16120	<b>784</b>	<b>30.9</b>	
<b>TOTAL</b>																<b>31.7</b>	

Prepared By: Muhd Shahfariz	Reviewed By: Kung Yee Han	Date: 20/6/2023	Rev. Rev.0	Controlled Document DB-CT-MSF-23011	Pg. 11
--------------------------------	------------------------------	--------------------	---------------	----------------------------------------	-----------

<b>DIMENSION BID</b>	DIMENSION BID COILED TUBING SERVICES		
	ANGSI A-25	SAND CLEANOUT & RE- PERFORATION	

**COILED TUBING STRING INFORMATION**

<i>OD (in)</i>	<i>Spec</i>	<i>W/T (in)</i>	<i>ID (in)</i>	<i>Length (ft)</i>
1.5	Jason	0.118	1.264	19,780 ft
<b>CT Volume: 30.7 bbls</b>				

**CT STRING FATIGUE (Jason 683330)**

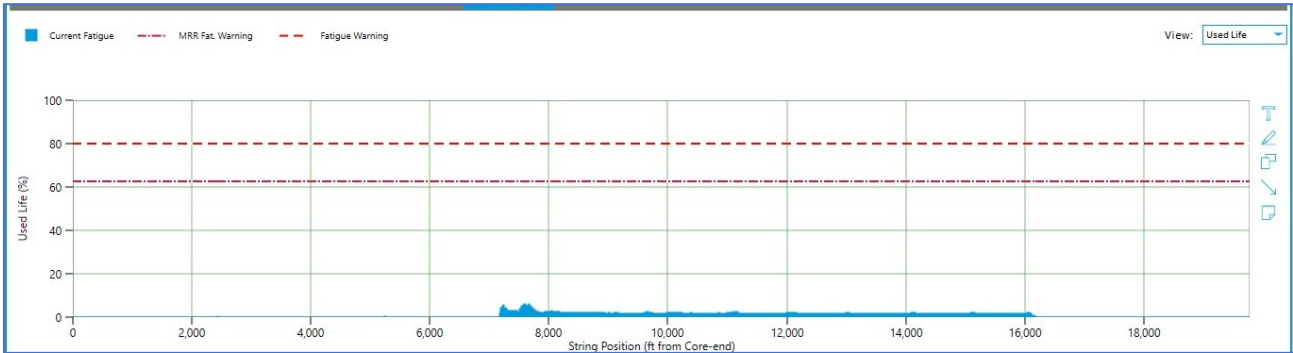

<b>DIMENSION BID</b>	DIMENSION BID COILED TUBING SERVICES		
	ANGSI A-25	SAND CLEANOUT & RE- PERFORATION	

**CT STRING # 683330 LATEST PIPE MANAGEMENT**

Based on above pipe management;

- Current CT Length is **19,780 ft.**
- Current String Used Life is **5.97 %.**
- Current Running Footage in Chrome Completion is 62,862 ft
- Current Total Running Footage is **62,862 ft.**

Based on Dimension Bid Standard Operating Procedure (SOP) of Pipe Management for Chrome Completion:

- Max Running Footage in Chrome Completion is **200,000 ft**

Based on Dimension Bid Standard Operating Procedure (SOP) of Pipe Management to junk the CT:

- **100%** of CT String Life reached
- Experienced two separate pinholes for the same CT String
- CT String exceed max working pressure

Prepared By: Muhd Shahfariz	Reviewed By: Kung Yee Han	Date: 20/6/2023	Rev. Rev.0	Controlled Document DB-CT-MSF-23011	Pg. 13
--------------------------------	------------------------------	--------------------	---------------	----------------------------------------	-----------

### PROCESS FLOW DIAGRAM

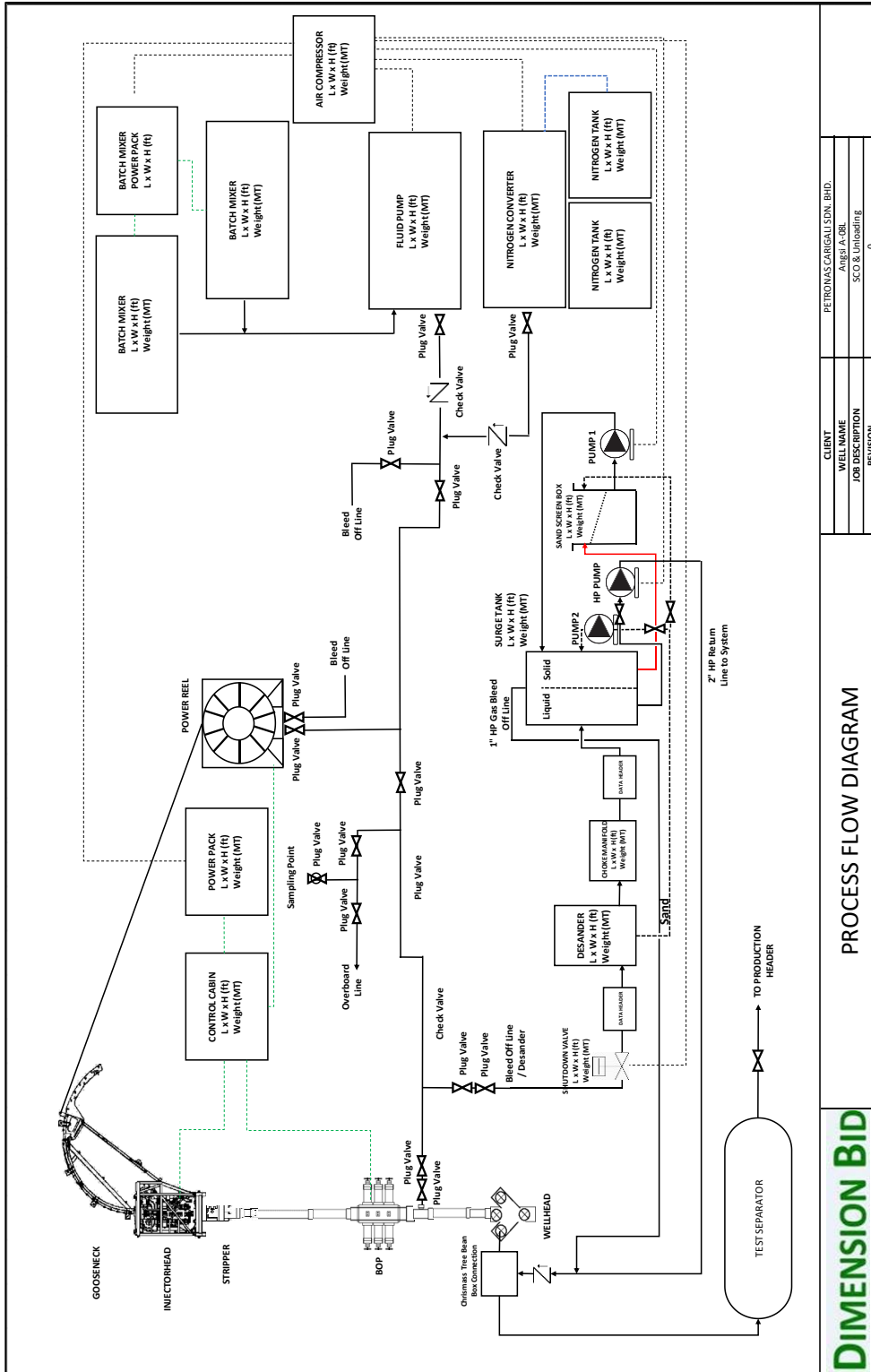

**DIMENSION BID**

PROCESS FLOW DIAGRAM

CLIENT	PETRONAS CARIGALI SDN. BHD.
WELL NAME	ANGSI A-25
JOB DESCRIPTION	SCO & Unloading
REVISION	0

<b>DIMENSION BID</b>	DIMENSION BID COILED TUBING SERVICES		
	ANGSI A-25	SAND CLEANOUT & RE- PERFORATION	

## SAFETY OPERATIONAL PROCEDURES

**Prior to commencement of the Coiled Tubing / Bull-heading operation, a pre-job meeting will be held. This should be attended by the following parties as a minimum:**

OIM, WSS, Coiled Tubing Supervisor, Representatives of other service companies involved and others as necessary.

**Safety meetings should be held at the start of every shift and risk assessments must be evaluated during this time. Tool box talks should be held immediately prior to the job execution.**

**Note: The safety meeting must be driven by DB Supervisor addressing the following topics as a minimum:**

1. Muster point.
2. Take list of personnel on site (Head count)
3. All personnel should review and be familiar with escape routes and emergency procedures.
4. Describe the **job objective, fluids and volumes to be pumped, pressures expected** during the job, and others.
5. Review **Dimension Bid Operations Policy and Procedure Manual**.
  - 5.1. Ensure at all steps carried out during the operations comply with this Manual.
  - 5.2. Management of change **MUST** be applied any time there is a need to deviate from the steps contained this procedure.
  - 5.3. A document **MUST** be created describing each the step of the deviation. This document shall also include the deviation Risk Assessment and it **MUST** be approved and signed by PCSB – Head of Well Intervention and Dimension Bid Operations Manager.
6. Exercise stops work authority if unsafe condition occurs and assess situation with all team members, resume operation after mitigation plan is in place.
7. Personnel responsibilities throughout the job.
8. Spills, fire, blow out, unexpected well behaviour.
9. Emergency shower station and eye wash station location.
10. Trapped potential energy such as pressure or coiled tubing stiffness.
11. Prepare related Job Hazard Analysis (JHA) prior commencement of any work, get approval from Client Site Representative (CSR) and review it with all personnel involved as well as to review Risk Assessment.
12. Discuss the well H<sub>2</sub>S, CO<sub>2</sub>, Hg (Mercury) content (if applicable).
13. Adhere all **PCSB Zeto Rules** and other guidelines.
14. Take a physical count of inventory and make sure all required materials are available on site.
15. **Barricade** the work area and display the appropriate **warning sign**.
16. On chemical mixing and handling; all personnel involved shall hold **safety meeting** and review **Safety Data Sheet** (SDS).
  - 16.1. Personnel involve during chemical handling shall be briefed by DB Chemical Specialist onsite and extra precautions must be taken. All SDS must be available on site and reviewed prior chemical handling.
  - 16.2. All non-essential personnel shall stay away from mixing site.
  - 16.3. Use PPE including respirators, hard hats, eye protection and steel-toed boots.
  - 16.4. Verify if there is any **dead Volume** in the mixing tanks and adjust volumes to account for non-usable volume in the blender / mix tank.

Prepared By: Muhd Shahfariz	Reviewed By: Kung Yee Han	Date: 20/6/2023	Rev. Rev.0	Controlled Document DB-CT-MSF-23011	Pg. 15
--------------------------------	------------------------------	--------------------	---------------	----------------------------------------	-----------

<b>DIMENSION BID</b>	DIMENSION BID COILED TUBING SERVICES		
	ANGSI A-25	SAND CLEANOUT & RE- PERFORATION	

- 16.5. Consider wind direction and note all trip hazards in the mix / pumping area.
- 16.6. Prior to mixing chemicals, clean and verify the tank/batch mixer and lines are free of any debris and or contaminants.
- 16.7. In case of spill; wash the place where any chemical has been spilt with available spill kit.
- 16.8. Take care to prevent leakage due to ejection from valves, fittings, flanges, or other joints flexible chemical hoses and pumps. Never repair the equipment during transfer into mixing tank/container.
17. Take reading of Shut in / Flowing Tubing Head Pressure (SI/FTHP), Casing Head Pressure (CHP) and fluid sample (if available) prior to operation.
18. Check gas lift condition and capability with Site Operation Representative (SOR).
19. Ensure fitness prior to perform duties assigned.
20. Ensure all barriers are in place and followed.

### HEALTH, SAFETY & ENVIRONMENT

1. Evaluate possible risks to arise during the job execution.
2. Evaluate risk assessment. Report any abnormal or insecure condition on site, taking into account all the steps or procedures to follow. Discuss with PCSB HSE coordinator, the execution or suspension of the job.
3. Review SDS of each product that will be used. Verify that all personnel on location handling toxic or corrosive products have the proper PPE.
4. Review the contingency plan for spills.
5. Do not vent / release any hydrocarbons from the well to atmosphere. Returns from the well should be handled safely by Flowback Company.
6. Prior to DB personnel walking on upper deck, DB Supervisor to inspect upper deck and ensure that the area it is in good condition (Gratings, Hatches, etc.)

Prepared By: Muhd Shahfariz	Reviewed By: Kung Yee Han	Date: 20/6/2023	Rev. Rev.0	Controlled Document DB-CT-MSF-23011	Pg. 16
--------------------------------	------------------------------	--------------------	---------------	----------------------------------------	-----------

<b>DIMENSION BID</b>	DIMENSION BID COILED TUBING SERVICES		
	ANGSI A-25	SAND CLEANOUT & RE- PERFORATION	

## EQUIPMENT RIG UP PROCEDURE

Conduct safety meeting with all personnel on location detailing the program, pressure limitations, and personnel responsibilities, well control emergency drill and safety precautions.

1. Spot the equipment accordingly to space availability, ensure reel position is aligned with the well.
2. Spot jacking frame at available space with sufficient height and crane capacity to rig up the injector head and gooseneck.
3. Rig up the 4" LP hoses from fluid storage tanks to batch mixer and single pump unit
4. Rig up 2" HP treating line as per DB Technical Standard from single pump unit and N2 converter unit to coiled tubing reel manifold. Include bleed off line on both lines as well.
5. Install correct wellhead crossover on the wellhead. Ensure well is fully secure and record the MV and CV turns.
6. Install Blowout Preventer (BOPs):
  - 6.1. Rig up Single BOP with necessary length of risers on top of the wellhead crossover.
  - 6.2. Rig up Combi BOP with flow tee above the risers
  - 6.3. Hook up BOP hoses and conduct function test for each ram.
7. Rig up 2" kill line from single pump unit line to BOP kill port
8. Rig up flow back line from flow tee to Choke manifold -> desander unit / production system
9. Spot injector head assembly with jacking frame on top of wellhead area. Ensure the gooseneck is aligned with the reel position
10. Inspect the chain and gripper block condition and ensure the alignment is correct
11. Rig up the following hydraulic hoses:
  - 11.1. From CT Power Pack to CT Control Cabin
  - 11.2. From CT Power Pack to CT Injector hose reel
  - 11.3. From CT Control Cabin to CT Reel
  - 11.4. From CT Control Cabin to CT BOPs
  - 11.5. From CT Power Pack to Jacking Frame
12. Perform EMC 1 for all equipment. Start up and run all equipment for few minutes.
13. Jack up CT control cabin.
14. Function test both BOP rams.

\*Observe indicator pin to confirm that all rams are in good working condition.
15. Install the stab-in-guide on the CT then stab the string into injector head.
16. Make up the CT connector and perform pull test at least **16,000 lbs** as per DB SOP. This test to be recorded in OrionNet.

\*Do not perform pull test more than 80% from CT Limit.
17. Install pressure test plate onto the CT connector.
18. Circulate the string & flowback line with water until clean return is seen prior to proceed with pressure test CT Connector.
19. Pressure up the CT string to 5,000 psi gradually by 500 psi increment then hold for 10 minutes. Pressure test acceptance criteria:

Prepared By: Muhd Shahfariz	Reviewed By: Kung Yee Han	Date: 20/6/2023	Rev. Rev.0	Controlled Document DB-CT-MSF-23011	Pg. 17
--------------------------------	------------------------------	--------------------	---------------	----------------------------------------	-----------

<b>DIMENSION BID</b>	<b>DIMENSION BID COILED TUBING SERVICES</b>		
	ANGSI A-25	SAND CLEANOUT & RE- PERFORATION	

- 19.1. For low pressure at 300 psi:  
**Acceptance criteria: No visible leaks. Pressure drop is less than 10% (above 270 psi) over 5-minutes test interval after the pressure stabilizes.**
- 19.2. For high pressure at 5,000 psi:  
**Acceptance criteria: No visible leaks. Pressure drop is less than 10% (above 4,500 psi) over the 15- minutes test interval after the pressure stabilizes**
20. Open the needle valve to release the pressure slowly.
21. Make up the BHA onto the string as per BHA diagram provided.
22. Use the jacking frame to pick up the injector and risers then connect to the Combi BOP. Secure down the injector assembly with chains.
23. Measure the following length to set the CT depth:

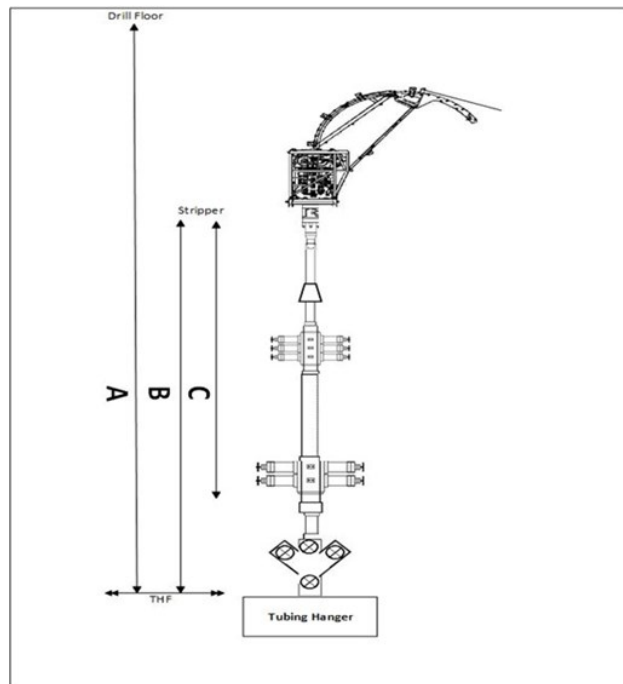

Distance	Length (ft)
<b>A:</b> Tubing Hanger (THF) to RKB	
<b>B:</b> Tubing Hanger (THF) to Stripper	
<b>C:</b> BHA Length	

\*The reference depth is at the tip of BHA

24. Pick up CT and tag the stripper to set CT depth based on this calculation "A-B+C".

<b>DIMENSION BID</b>	DIMENSION BID COILED TUBING SERVICES		
	ANGSI A-25	SAND CLEANOUT & RE- PERFORATION	

## EQUIPMENT PRESSURE TESTING PROCEDURE

Conduct safety meeting with all personnel on location detailing the program, pressure limitations, and personnel responsibilities; well control emergency drill and safety precautions. Refer the following procedure to pressure test BOP Body, Blind Ram, Surface Line and Wellhead connection.

1. Isolate the line to Coiled Tubing. Double confirm the valve is closed.
2. Fill and pressure test the treating line with water to 500 psi and hold for 5 minutes. Inspect the lines for leaks and observe for any pressure drop.
3. Increase pressure to 3,000 psi and hold for 10 minutes. Inspect the lines for leaks and observe for any pressure drop.
4. Fill the pressure control equipment and ensure air is vented from the system by leaving the blind ram and blind ram equalizing valves open.
5. Close blind ram and equalizing valve. Pressure up the surface lines, BOP body, blind rams and wellhead connection to 500 psi then increase gradually to 3000 psi through the kill line, hold for 10 minutes. Inspect the lines for leaks and observe for any pressure drop. PT acceptance criteria as per below:

5.1. For low pressure at 500 psi:

**Acceptance criteria: No visible leaks. Pressure drop is less than 10% (above 450 psi) over 5-minutes test interval after the pressure stabilizes.**

5.2. For high pressure at 3,000 psi:

**Acceptance criteria: No visible leaks. Pressure drop is less than 10% (above 2,700 psi) over the 15- minutes test interval after the pressure stabilizes**

6. Once test complete, open blind ram pressure equalizing port then bleed off any residual pressure and open the blind rams.

Conduct safety meeting with all personnel on location detailing the program, pressure limitations, and personnel responsibilities; well control emergency drill and safety precautions. Refer the following procedure to pressure test BOP Body, Blind Ram, Surface Line and Wellhead connection.

1. Fill up the CT string and stack up until leak can be seen at stripper.
2. Energize the stripper and begin pressure test the complete stack up (CT string, stripper, CT stack and risers) to 3,000 psi against Crown Valve, hold for 10 minutes.
3. Bleed off pressure inside CT to 0 psi to test the Double Flapper Check Valve to 1,500 psi and hold for 10 minutes. Do not apply pressure more than CT Collapse Pressure (1500 psi).
4. Bleed off the pressure from BOP kill port side.
 

\*Step 4-8 can be neglected if pipe ram has been pressure tested prior to the job.
5. Place CT string across pipe ram then close the ram.
6. Open pipe ram equalizing valve then fill up the BOP slowly.
7. Close the equalizing valve and begin pressure test the pipe ram to 3,000 psi, hold for 10 minutes.
8. When the tests are complete, bleed off the pressure.

Prepared By: Muhd Shahfariz	Reviewed By: Kung Yee Han	Date: 20/6/2023	Rev. Rev.0	Controlled Document DB-CT-MSF-23011	Pg. 19
--------------------------------	------------------------------	--------------------	---------------	----------------------------------------	-----------

<b>DIMENSION BID</b>	DIMENSION BID COILED TUBING SERVICES		
	ANGSI A-25	SAND CLEANOUT & RE- PERFORATION	

## OPERATIONAL PROCEDURE

### SLICKLINE OPERATION

All depths specified below are in m-MDDF (**Drill floor to THF is 16.9-m as per well schematic**)

- Slickline to conduct TCC run to ensure the tubing path is clear from obstruction and record the min ID of the tubing:

<i>Drift ID</i>	<i>Unit</i>

- If fluid level or encountered HUD is found, record it in the following table:

<i>Description</i>	<i>Depth (m)</i>
Fluid level	
HUD	

- Once completed, rig down Slickline unit and handover well to CT operation.

Prepared By: Muhd Shahfariz	Reviewed By: Kung Yee Han	Date: 20/6/2023	Rev. Rev.0	Controlled Document DB-CT-MSF-23011	Pg. 20
--------------------------------	------------------------------	--------------------	---------------	----------------------------------------	-----------

<b>DIMENSION BID</b>	DIMENSION BID COILED TUBING SERVICES		
	ANGSI A-25	SAND CLEANOUT & RE- PERFORATION	

**COILED TUBING OPERATION – RUN#1 SAND CLEANOUT UNTIL 20m below bottom perforation I15U at depth 4,725m-MDDF**

All depths specified below are in m-MDDF (Drill floor to THF is 16.9-m as per well schematic)

Conduct safety meeting with all personnel on location detailing the program, pressure limitations, personnel responsibilities, emergency well control drill, and safety precautions.

1. Rig up coiled tubing unit and surface line on Angsi-A platform as per Site Visit Report:
  - 1.1. Review JHA and risk assessment with all personnel involve in the rig up operation. Please send a copy of JHA to Engineer in Charge.
  - 1.2. Lift up coiled tubing unit using crane and spot on platform.
  - 1.3. Rig up Coiled Tubing package and surface treating line.
  - 1.4. Rig up 2” kill line to BOP kill port.
  - 1.5. Rig up 2” flexible hose from pumping tee.
  - 1.6. Ensure pump volume, pump rate, N2 rate, circulating pressure, well head pressure, weight is synchronise with OrionNet DAS.
  - 1.7. Pig coil tubing with treated sea water to ensure no debris is inside coil. **Record coil tubing volume in treatment report.**
  - 1.8. Make up the **CT End Connector**.
  - 1.9. Install the Pull and Pressure Test Sub.
  - 1.10. Perform Pull Test on the CT End Connector **to 15,000 lbf** and record this in OrionNet.
  - 1.11. Perform Pressure Test on CT End Connector. Pumping treated sea water through the coiled tubing, apply low pressure test of **300 psi for 5 minutes** and high-pressure test of **5,000 psi for 15 minutes** after stabilization. Record the pressure test.

**Note: Do not perform pull test more than 80% coil limit. Consult with town if require.**

1.11.1. For low pressure:

**Acceptance criteria: No visible leaks. Pressure drop is less than 10% (above 270 psi) over 5-minutes test interval after the pressure stabilizes.**

1.11.2. For high pressure:

**Acceptance criteria: No visible leaks. Pressure drop is less than 10% (above 4,500 psi) over the 15- minutes test interval after the pressure stabilizes.**

2. Prepare 100 bbls of Treated Injection Water, TIW as per recipe below:

Treated Injection Water (TIW)				100	BBL	Description
Seq.	Product	Concentration		Volume		
1	Injection Water	992	gptg	4,166	gal	Base Fluid
2	ACM H2S Clear 200	2	gptg	8	gal	CO2 & H2S Corrosion Inhibitor
3	ACM BACT 200	2	gptg	8	gal	Micro Biocide Control
4	ACM OXYFREE 100	2	gptg	8	gal	Oxygen Scavenger
5	MESB NE-Surf 200	2	gptg	8	gal	Non-Emulsifier Surfactant

**Mixing Instruction:**

1. Prepare injection water in the mixing tank.
2. Add ACM H2S Clear 200 & ACM OXYFREE 100 into the tank and circulate the mixture.
3. Add ACM BACT 200 & NE-Surf 200 into the tank and circulate the mixture until homogenous.

Prepared By: Muhd Shahfariz	Reviewed By: Kung Yee Han	Date: 20/6/2023	Rev. Rev.0	Controlled Document DB-CT-MSF-23011	Pg. 21
--------------------------------	------------------------------	--------------------	---------------	----------------------------------------	-----------

<b>DIMENSION BID</b>	DIMENSION BID COILED TUBING SERVICES		
	ANGSI A-25	SAND CLEANOUT & RE- PERFORATION	

**Note:** The above recipe is for 100bbls of TIW. Please prepare another batch of TIW once needed.

3. Prepare 50bbls of D801 Cleanout Gel as per recipe below:

D801 Cleanout Gel				50	BBL	Description
Seq.	Product	Concentration		Volume		
1	Injection Water	992	gptg	2,083	gal	Base Fluid
2	D801 Gel	40.5	pptg	85	lbs	Gelling Agent
<b>Mixing Instruction:</b>						
1. Prepare injection water in the mixing tank.						
2. Add D801 Gel into the tank and circulate the mixture until homogenous.						

**Note:** The above recipe is for 50bbls of D801 Gel. Please prepare another batch of D801Gel once needed.

4. Make up 2-1/8" Spin-Cat Nozzle tool as per **BHA#1: 2-1/8" Spin-Cat Nozzle** in **Appendix 1**.
5. Perform function test of the Spin-Cat Nozzle to determine at which pump rate and pressure of the tool. Record the data in the table below, do not exceed 5,000psi.

Flow rates (bpm)	Pressure (psi)	Remark
0.3		
0.5		
0.6		
0.7		
0.8		
0.9		
1.0		
1.1		
1.2		
1.3		

6. Pick up coiled tubing and tag the stripper with the BHA.
7. Make up the Injector Head and Stripper to the stack up.
8. Coiled tubing stack up pressure test against Wellhead Swab valve. Pumping treated sea water through the coiled tubing, apply low pressure test of **300 psi for 5 minutes** and high-pressure test of **3,000 psi for 15 minutes** after stabilization. Record the pressure test. Record test on a chart. Upon successful pressure test, bleed off pressure via Pump-In Sub.
- 8.1. For low pressure:  
**Acceptance criteria: No visible leaks. Pressure drop is less than 10% (above 270 psi) over 5-minutes test interval after the pressure stabilizes.**
- 8.2. For high pressure:  
**Acceptance criteria: No visible leaks. Pressure drop is less than 10% (above 2,700 psi) over the 15- minutes test interval after the pressure stabilizes.**
9. Pressure test the BHA Check Valve. With **3,000 psi** in the coiled tubing stack up, bleed off the stack up pressure to **1,500 psi** via pump-in sub; and bleed off pressure in the coiled tubing to zero (0) psi via reel manifold.
- 9.1. Acceptance criteria: **Pressure drop is less than 10% (above 1,350 psi) over the 15- minute test interval after the pressure stabilizes.** Observe for any pressure changes in the stack up. If the BHA check valve is not holding, proceed to replace the MHA; do not run-in hole with leaking check valve; repeat steps 8.2 and 9.
10. Upon successful test, bleed off the pressure in the coiled tubing stack up to zero through the pump-in sub.
11. Zero both depth counters at reference point.

Prepared By: Muhd Shahfariz	Reviewed By: Kung Yee Han	Date: 20/6/2023	Rev. Rev.0	Controlled Document DB-CT-MSF-23011	Pg. 22
--------------------------------	------------------------------	--------------------	---------------	----------------------------------------	-----------

<b>DIMENSION BID</b>	DIMENSION BID COILED TUBING SERVICES		
	ANGSI A-25	SAND CLEANOUT & RE- PERFORATION	

12. Confirm all wellhead and BOP valves are in open position via physical check.
  - 12.1. Prior to opening the wellhead valve pressure up above master valves to a pressure equal to the expected shut-in wellhead pressure.
  - 12.2. Count wellhead valves turns while opening and record it the treatment report for reference in future.
  - 12.3. Manipulate surface valve to the following position:

Valve	Position
Reel Manifold	OPEN
Flow Cross Return Valve (Cetco lines)	OPEN
Wing Valve	CLOSE

13. Start running in hole coil tubing to **4,664.1m-MDDF (10m above EOT)** while pumping **Treated Injection Water** at 0.3BPM.
  - 13.1. Refer to CT Tubing Force simulation (Orpheus modelling), refer Appendix III.
  - 13.2. Conduct pull test as per for every 300m (1,000ft), use CT Fatigue graph as reference. **Ensure the CT Fatigue graph is available at location before RIH. Record RIH, Hanging and POOH weight in treatment report.**
  - 13.3. Maximum coil speed running in hole is **30-50 ft/min**.
  - 13.4. Slow down coil speed to **10 ft/min**, 50 ft before and after passing through completion accessories.
  - 13.5. Closely observe weight indicator in control cabin while running in hole.
  - 13.6. Observe return all the times.
  - 13.7. Regularly inform WSS on job status at all times.
  - 13.8. Do not exceed operating safety limits **5,000 psi**.
  - 13.9. If the well condition differs from original job design, contact appropriate personnel in charge before proceeding.
  - 13.10. At all time, while run-in hole, the injector torque control shall be set at the minimum pressure required to move the Coiled Tubing at specified speed.
14. Once CT reach **4,664.1m-MDDF (10m above EOT)**, conduct pull test of 10m/30ft with pumping rate 0.3B PM and record the pulling weight both static and dynamic (**IMPORTANT**).

Depth, ft	RIH weight, lbf	Static weight, lbf	Pick up weight, lbf

15. If CT encounter HUD inside tubing, **flag CT on surface** and record in report as our reference point, pick up CT back to 10m above HUD. Increase pump rate to maximum pump rate achievable (with reference to pump rate in **step 5**) before start penetrate the HUD. Continue circulating until good return establish at surface. (Skip this step if no HUD recorded inside tubing)
16. Start to introduce nitrified TIW (**0.8BPM, 400scfm**). Proceed as per table **16.4**. (Skip to step 17 if no HUD inside casing till 4,725m-MDDF)
 

**Note:** Pump rate can be increase to max 1.3bpm or until reach maximum circulating pressure of 5,000 psi.

  - 16.1. Once good return observed at surface, continue to penetrate into HUD with 5ft/min CT speed. Circulate 5bbls of D801 gel after each penetration of 10m/30ft bite
  - 16.2. **IF** no return is observed on surface, continue to fill up tubing with 1.5 Tubing Volume of TIW. Monitor pressure on CHP if there are any build ups and fluid return observe on tubing and casing (Tubing communicate with A-Annulus).
    - 16.2.1. **IF** no pressure built up in CHP and returns established at surface, proceed with Step 16.4.

Prepared By: Muhd Shahfariz	Reviewed By: Kung Yee Han	Date: 20/6/2023	Rev. Rev.0	Controlled Document DB-CT-MSF-23011	Pg. 23
--------------------------------	------------------------------	--------------------	---------------	----------------------------------------	-----------

<b>DIMENSION BID</b>	DIMENSION BID COILED TUBING SERVICES		
	ANGSI A-25	SAND CLEANOUT & RE- PERFORATION	

16.2.2. **IF** no constant return is observed on surface after exceeding **1.5 tbg volume** of TIW with a pressure build up on CHP, continue fill up until return observe on PCP and return establish at tubing.

16.3. **IF** no constant return is observed on surface, introduce nitrogen at pumping rate (300 – 400 scf/min).

16.3.1. Monitor THP and well condition while establishing return.

16.3.2. Upon establishing constant return, proceed with penetrate the HUD.

**Perform wiper trip for every 10m/30ft interval cleanout (from cleanout depth until initial depth) while pumping 5bbls of D801 Gel.**

16.4. Continue penetrate HUD as per below table until **4,725m-MDDF**. **Ensure to turn on the gas lift.**

No.	Stage	Fluid	Liquid Rate	Total Liquid	N2 Rate	CT Speed	Duration	Depth	Remarks
			BPM	BBL	SCF/M	ft/min	Minute	m	
1	CT at 10m above HUD	TIW	0.8	0.0	400	0	0	10m above HUD	Establish return on surface with <b>aid of gas lift</b>
2	RIH to HUD and Penetrate HUD/Fill	TIW	0.8	4.8	400	5	6	HUD + 10m	Monitor return & CT weight on surface
3	Circulate	D801 Gel	0.8	5.0	400	0	6		Provide suspension to the fill and lift to surface
Pull Test to EOT at depth 4,674.1m-MDDF									
4	RIH to last HUD and Penetrate HUD/Fill	TIW	0.8	4.8	400	5	6	HUD + 10m	Monitor return & CT weight on surface
5	Circulate	D801 Gel	0.8	5.0	400	0	6		Provide suspension to the fill and lift to surface
Pull Test to EOT at depth 4,674.1m-MDDF									
Repeat above step until reached 4,725m-MDDF (20m below bottom perf I15)									
6	Hole Cleaning (Circulate)	D801 Gel	0.8	107	400	0	107	Stationary CT at 4,725m MDDF	Hole cleaning stage. 1.0x CT/Tubing Annulus Volume
7	Bottoms Up (Circulate)	TIW	0.8	161	400	0	161	Stationary CT at	Hole Cleaning stage. 1.5x

Prepared By: Muhd Shahfariz	Reviewed By: Kung Yee Han	Date: 20/6/2023	Rev. Rev.0	Controlled Document DB-CT-MSF-23011	Pg. 24
--------------------------------	------------------------------	--------------------	---------------	----------------------------------------	-----------



<b>DIMENSION BID</b>	DIMENSION BID COILED TUBING SERVICES		
	ANGSI A-25	SAND CLEANOUT & RE- PERFORATION	

- 19.2. Upon completion mixing 15% HCl acid, proceed to jet 5 bbls of 15% HCl on top of the obstruction while attempt to pass through the obstruction.
- 19.3. If no success during jetting HCl acid, proceed to spot another 5 bbls of 15% HCl on top of obstruction and pick up CT at least **550m** above the obstruction depth to soak the acid for 2 hours. After completed soaking, proceed to RIH to pass through the obstruction while pumping nitrified TIW.
- 19.4. If unable to penetrate, repeat step 18.1-18.3.
- 19.5. If still unsuccessful in clearing the HUD, consult town, flag CT string on surface and POOH to
- 19.6. surface.
- 19.7. During circulation, if acid return observes on surface return line, inject soda ash using chemical injection pump on the surface return line to neutralize the acid.
20. Once completed CBU and observed clear return is established. POOH CT with tripping speed 20ft/min while pumping TIW 0.8BPM. Ensure continuous return on surface is observed.
  - 20.1. Maximum coil speed while POOH is 50ft/min.
  - 20.2. Slow down coil speed to 10ft/min 50ft before and after passing through completion accessories.
21. Once CT on surface, close well and bleed off pressure in coil and stack up.
22. Proceed for GRCCL with 2-3/8" Dummy Gun.

Prepared By: Muhd Shahfariz	Reviewed By: Kung Yee Han	Date: 20/6/2023	Rev. Rev.0	Controlled Document DB-CT-MSF-23011	Pg. 26
--------------------------------	------------------------------	--------------------	---------------	----------------------------------------	-----------

<b>DIMENSION BID</b>	<b>DIMENSION BID COILED TUBING SERVICES</b>		
	ANGSI A-25	SAND CLEANOUT & RE- PERFORATION	

**COILED TUBING OPERATION – RUN#2 GRCCCL c/w 2-3/8” Dummy Gun**

Slickline-Stack-up Proposal

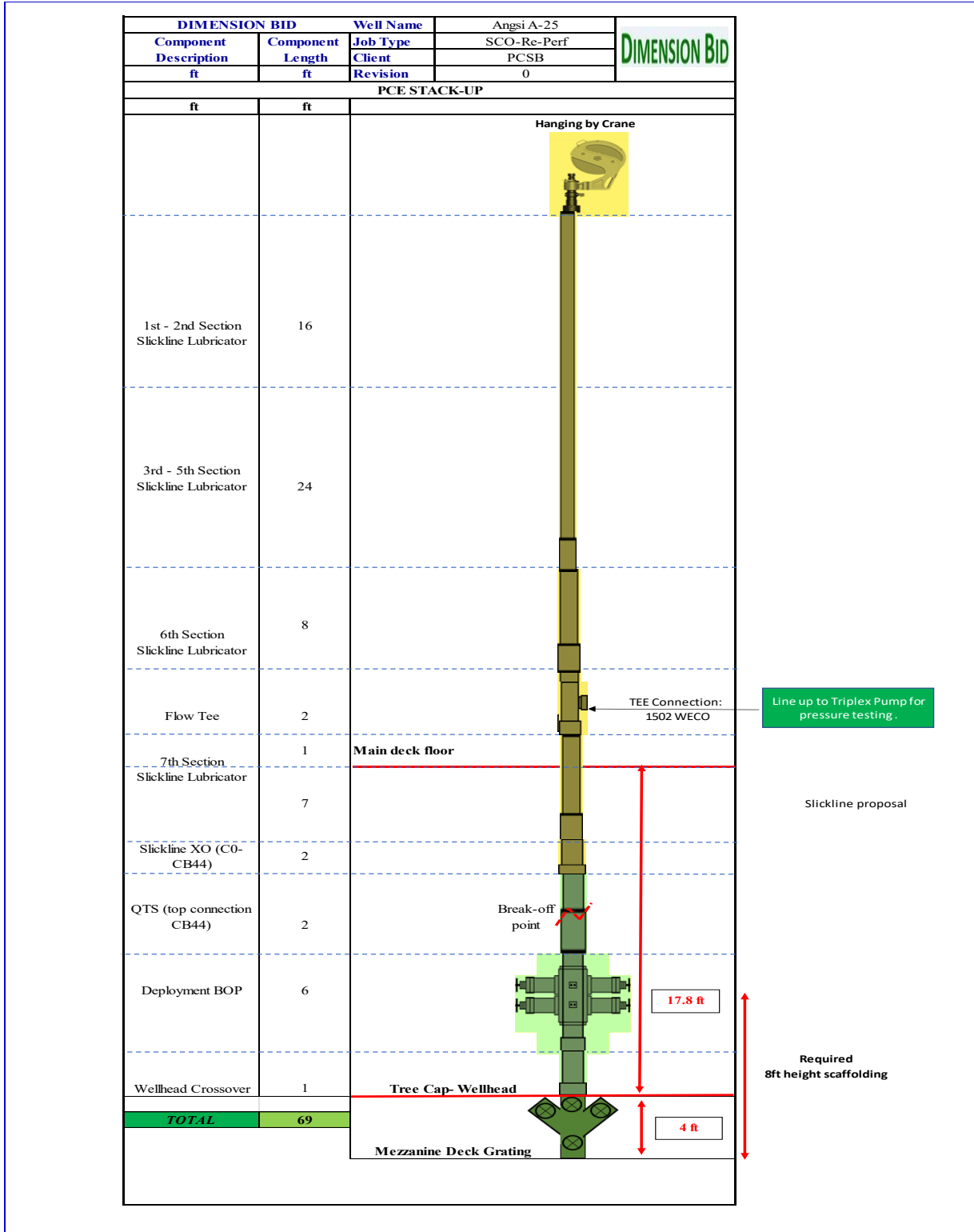

<b>DIMENSION BID</b>	<b>DIMENSION BID COILED TUBING SERVICES</b>		
	ANGSI A-25	SAND CLEANOUT & RE-PERFORATION	

CT-Stack-up Proposal

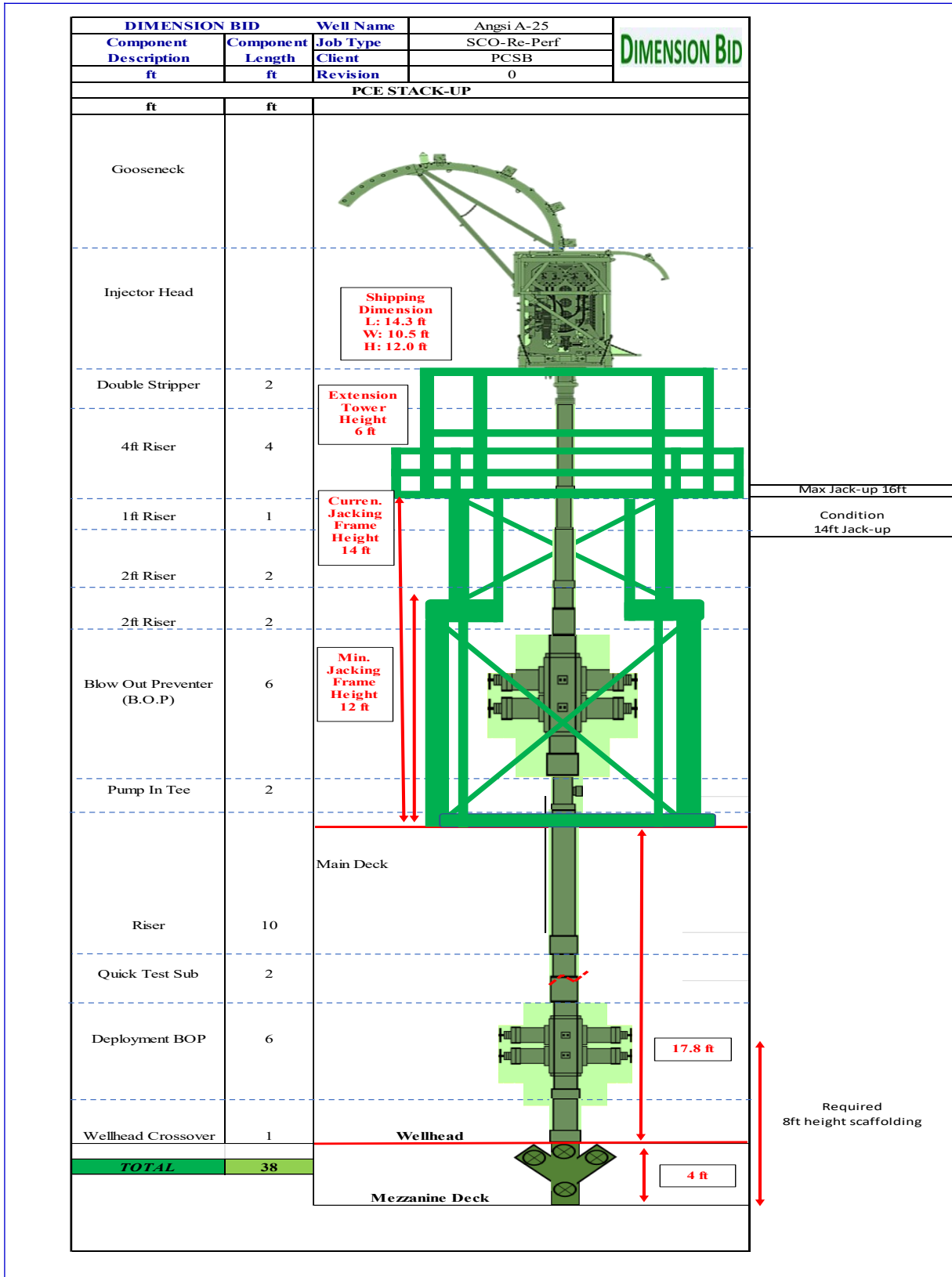

<b>DIMENSION BID</b>	DIMENSION BID COILED TUBING SERVICES		
	ANGSI A-25	SAND CLEANOUT & RE- PERFORATION	

Pressure Deployment Rig up Procedure

23. Pressure Test CT Stack up against the crown valve as per normal procedure. (Refer step 8)
24. Break the stack up at the QTS connection and bring down the injector head, stripper, riser and Combi BOP.
25. The dummy gun c/w GRCCL BHA will be in 2 sections.

Section	Items		Description	Length
1	1	DB	Connector	3.07ft
	2	DB	CT MHA	
2	3	SLB	Carsacs	28.35ft
	4	SLB	Dual Ball Kelly Cock Valve	
	5	SLB	Deployment Bar	
	6	SLB/Uzma	Crossover	
	7	Uzma	Crossover (CRP)	
	8	Uzma	Firing Head (0.5" Drop Ball)	
	9	Uzma	2-3/8" 6SPF 11ft Gun + Top Sub	
	10	Uzma	BullPlug SR	
	11	Uzma	1.69" GRCCL Tool	

26. Make up 56-ft slickline lubricator (7set lubricator) with upper section of QTS on the platform deck.
27. Insert slickline lubricator on top of the CT deployment BOP. Perform pressure test of the lubricator against the crown valve.
  - 27.1. Note: this test will confirm the integrity of the lubricator. No pressure test required on the lubricator after this.
  - 27.2. Only need to pressure test using QTS connection.
28. Break the QTS and position slickline lubricator above bring to side by side to CT deployment BOP.
29. Make the 2nd section BHA until the deployment bar and position the deployment bar across the deployment BOP.
30. Ensure 1.5" section is positioned across the both pipe/slip rams of the CT deployment BOP.
  - 30.1. Note make sure DFKV is in closed position. This will act as the pressure barrier for CT side.
31. Measure and flag the distance of the slickline the when the deployment bar is across CT deployment BOP.
32. Proceed to make-up 10metre dummy gun c/w GRCCL BHA and the firing head.
33. Pick-up slickline lubricator with crane and suck all the 2<sup>nd</sup> section inside the lubricator.
34. Connect slickline lubricator with CT deployment BOP with QTS and perform Pressure test the QTS connection.
35. Equalize pressure and open the wellhead slowly. (Crown and master valve)
36. RIH slickline based on the **flag** and depth recorded earlier. This will indicate that the deployment bar is across the pipe/slip rams of the CT deployment BOP.
37. Close pip/slip rams of the CT deployment BOP and manually lock the both rams.

Prepared By: Muhd Shahfariz	Reviewed By: Kung Yee Han	Date: 20/6/2023	Rev. Rev.0	Controlled Document DB-CT-MSF-23011	Pg. 29
--------------------------------	------------------------------	--------------------	---------------	----------------------------------------	-----------

<b>DIMENSION BID</b>	DIMENSION BID COILED TUBING SERVICES		
	ANGSI A-25	SAND CLEANOUT & RE- PERFORATION	

38. Perform light weight check by pulling the slickline cable to observe the weight increase and make sure both pipe/slip rams are functioning good.
39. Bleed off pressure from slickline lubricator using the bleed off point at flow tee.
40. Once complete bleed off, close the valve and monitor pressure for 15 minutes from the pressure gauge at the flow tee.
41. Any pressure increasing indicates the pipe/slip rams of the CT deployment BOP are not sealing properly.
42. Proceed to rig down slickline lubricator once it is confirmed no any pressure increase observed. Rig down slickline lubricator at QTS.
43. Skid in jacking frame with injector head and make up section-1 BHA
44. Connect section-1 & section-2 BHA at Carsac.
45. Equalized pressure against DKCV and proceed to open the DKCV.
46. Ensure both valves at DKCV are opened before RIH. If it is closed, unable to pump through CT.
47. Lower down the injector head while rotating the injector chain in POOH to connect the upper and lower QTS.
48. Connect the QTS and pressure test QTS.
49. Unlock the manual lock of the CT deployment BOP. Open the pipe/slip rams.
50. Take note on the distance need to pick up until tagged stripper, this distance will be used as the reference for the reverse deployment later during the end of the job.

Dummy Gun Procedure

51. Prior making up bottomhole assembly, note on the following: -
  - 51.1.1. **Drift 1/2" ball** through MHA to ensure it is able to pass through flapper check valve.
 

**Note: Ensure 1/2" ball has been tested drifted through MHA, witnessed by WSS to confirm that it can pass through smoothly to the required ball seat in setting tool.**
52. Drift 1/2" ball through the 1.5" coiled string and break circulation until the ball comes out below CT. This is to ensure the ball can pass through Gooseneck. Record the following details below.

Pump Volume, bbls	Pump Rate, bpm

53. Start RIH to **4,725m-MDDF**. (Max speed 50ft/min) while pumping TIW with 0.3BPM and circulation pressure less than 500psi.

Correlation Interval (m-MDDF)
4,655– 4,710m-MDDF

54. Once CT at depth to **4,725m-MDDF**, stop coil and conduct pull test of 5m. Record the pulling weight both static and dynamic (**IMPORTANT**).

Depth, ft	RIH weight, lbf	Static weight, lbf	Pick up weight, lbf

55. Pick up CT to depth **4,710m-MDDF**, repeat step in order to re-confirm the depth.

Prepared By: Muhd Shahfariz	Reviewed By: Kung Yee Han	Date: 20/6/2023	Rev. Rev.0	Controlled Document DB-CT-MSF-23011	Pg. 30
--------------------------------	------------------------------	--------------------	---------------	----------------------------------------	-----------

<b>DIMENSION BID</b>	DIMENSION BID COILED TUBING SERVICES		
	ANGSI A-25	SAND CLEANOUT & RE- PERFORATION	

56. Allow the tool to remain stationary about 5 minutes. Record the depth and static weight.

<i>Depth, ft</i>	<i>Static weight, lbf</i>

57. Flag Coil at surface. This will be **Flag#2 (GRCCCL Bottom of Logging Depth)**. Record the following and include in daily report.

<i>Flag Number</i>	<i>Colour</i>
Flag#2	

58. Start logging up at 30ft/min from **4,710m to 4,655m MDDF**. Once at 4,655 MDDF, allow the tool to remain stationary about 5 minutes.

59. Start RIH back to **4,710m-MDDF** and repeat logging passes. **A minimum of 2 passes is required for the average calculation.**

60. After complete logging, begin POOH CT to surface: -

60.1. Pump at minimum rate while POOH

60.2. Maximum coil speed while POOH is 50ft/min.

60.3. Slow down coil speed to 10ft/min 50ft before and after passing through completion accessories.

60.4. Do not exceed CT operating limit (refer to Appendix 6: CT Force simulation)

61. Once CT reaches at surface:

61.1. Close master and swab valve.

61.2. Break BHA and proceed for Add perf

Prepared By: Muhd Shahfariz	Reviewed By: Kung Yee Han	Date: 20/6/2023	Rev. Rev.0	Controlled Document DB-CT-MSF-23011	Pg. 31
--------------------------------	------------------------------	--------------------	---------------	----------------------------------------	-----------

<b>DIMENSION BID</b>	DIMENSION BID COILED TUBING SERVICES		
	ANGSI A-25	SAND CLEANOUT & RE- PERFORATION	

**COILED TUBING OPERATION – RUN#3 Re-perforation using 2-3/8” Spent Gun (10metre gun)**

62. Repeat step from 25 to 52 for pressure deployment rig up procedure and make up the 2-3/8” 10 metre gun.
63. The BHA will be in 3 sections.

Section	Items		Description	Length
1	1	DB	Connector	3.07ft
	2	DB	CT MHA	
2	3	SLB	Carsacs	44.61ft
	4	SLB	Dual Ball Kelly Cock Valve	
	5	SLB	Deployment Bar	
	6	SLB/Uzma	Crossover	
	7	Uzma	Crossover (CRP)	
	8	Uzma	Firing Head (0.5" Drop Ball)	
	9	Uzma	2-3/8" 6SPF 11ft Gun + Top Sub	
	10	Uzma	2-3/8" 6SPF 11ft Gun + Tandem Sub	
	11	Uzma	2-3/8" 6SPF 11ft Gun + Tandem Sub	
	12	Uzma	Bull Plug	

Gun Procedure

64. RIH as per CT operation procedure and position gun on depth or deeper (use flagging from correlation run as a reference)
65. Confirm coil conditions as expected and note total coil volume and surface coil volume. If well conditions allow, pump small volume of fluid at minimum rate to ensure the coil is full (max. 0.5bbl/min) – confirm with CT supervisor.
66. Pick up the gun to correct firing depth and ensure that the string depth is noted. After the gun tie in to the shooting depth, record wellhead pressure, coil tubing pressure and pick up weight.
- i) Wellhead pressure: \_\_\_\_\_
- ii) Coil Tubing Pressure: \_\_\_\_\_
- iii) Coil Tubing Pick Up Weight: \_\_\_\_\_
- Please refer to shear pin worksheet appendix.***
67. Re-caliper ball which was presented with the seat (witnessed & signed off by clients)
68. Position the reel to launching position. Insert **1/2”** ball into reel and confirm it is inside launcher.
69. Close launcher. Pressure up to **1500-2000 psi** and open low torque to launch ball into reel. After ball has been dropped to fire the gun, it is required that you must keep pumping until reaching at least the minimum calculated volume and pressure.
70. Pump at **1 bpm or 1000 psi** (these numbers will vary according to well conditions, CT/BHA sizes, fluids, etc.)

Prepared By: Muhd Shahfariz	Reviewed By: Kung Yee Han	Date: 20/6/2023	Rev. Rev.0	Controlled Document DB-CT-MSF-23011	Pg. 32
--------------------------------	------------------------------	--------------------	---------------	----------------------------------------	-----------

<b>DIMENSION BID</b>	DIMENSION BID COILED TUBING SERVICES		
	ANGSI A-25	SAND CLEANOUT & RE- PERFORATION	

71. Calculate coil tubing volume from end of coil to gooseneck.
72. Once the ball pass through gooseneck, stop pumping for 2-3 minutes to the ball free fall in vertical line. Start pumping and reduce pump rate to **0.3bpm or 500-1000 psi**.
73. Around the total coil volume, observe circulating pressure. A rise in the pressure is expected once the ball reaches the seat, and it may be not enough to reach the firing pressure. If required, increase pump rate to the maximum actuating pressure (**max to shear the pin: TBA psi**) raise CT pressure to shear the pins at the firing head. Ensure that amount of shear pins installed.

Check for 3 out of 4 Firing indicators:	Tick
Pressure decreases within calculated shear window (mandatory)	
Change of coil tension.	
Change of wellhead pressure	
Change of annulus pressure	

74. At least 3 clear indications of firing must be observed.
75. Check for circulation (main indication gun firing). Compare circulation rates and pressures with the rates and pressures previously observed. After firing, open circulation should be observed.
76. Upon confirmation that the guns have been detonated, POOH the coil with the BHA as fast as possible to 30m / 100ft above the perforated interval to avoid sticking.
77. Continue POOH taking care when pulling through the remaining completion assemblies.
78. Once at surface, lay down spent gun, pull next gun into the lubricator and tag the connector inside the stripper and close the Master Valve on the production tree. Secure & rig down surface equipment.
79. Proceed reverse deployment and re-do rig up deployment for next run.

### **COILED TUBING OPERATION – RUN#4 Re-perforation using 2-3/8” Spent Gun (10metre gun)**

80. Repeat steps in run#3.
81. Once completed, standby for contingency unloading.

Prepared By: Muhd Shahfariz	Reviewed By: Kung Yee Han	Date: 20/6/2023	Rev. Rev.0	Controlled Document DB-CT-MSF-23011	Pg. 33
--------------------------------	------------------------------	--------------------	---------------	----------------------------------------	-----------

<b>DIMENSION BID</b>	DIMENSION BID COILED TUBING SERVICES		
	ANGSI A-25	SAND CLEANOUT & RE- PERFORATION	

## COILED TUBING OPERATION – Contingency Unloading

82. In the event well unable to flow after the re-perforation, proceed for well unloading to create 500psi underbalanced condition.

**All depths specified below are in m-MDDF (Drill floor to THF is 16.9-m as per well schematic)**

83. This contingency run is made in case the well is still unable to flow after perf I-68.
84. Make up 2-1/8" Upward Jetting Nozzle tool as per **BHA#4: 2-1/8" Upward Jetting Nozzle** in **Appendix I**.
85. Repeat step in CT Run#1 procedure prior opening the well.
86. Ensure to purge the coil until it is dry before RIH.
87. Start running in hole coil tubing to the first circulation point depth at **414m-MDDF while pumping nitrogen at 300scf/min**.
- 87.1. Refer to CT Tubing Force simulation (Orpheus modelling), refer Appendix III.
- 87.2. Conduct pull test as per for every 300m (1,000ft), use CT Fatigue graph as reference. **Ensure the CT Fatigue graph is available at location before RIH. Record RIH, Hanging and POOH weight in treatment report.**
- 87.3. Maximum coil speed running in hole is **30-50 ft/min**.
- 87.4. Slow down coil speed to **10 ft/min**, 50 ft before and after passing through completion accessories.
- 87.5. Closely observe weight indicator in control cabin while running in hole.
- 87.6. Observe return all the times.
- 87.7. Regularly inform WSS on job status at all times.
- 87.8. Do not exceed operating safety limits **5,000 psi**.
- 87.9. If the well condition differs from original job design, contact appropriate personnel in charge before proceeding.
- 87.10. At all time, while run-in hole, the injector torque control shall be set at the minimum pressure required to move the Coiled Tubing at specified speed.
88. At **404m-MDDF**, stop coil and conduct pull test of 10m/30ft and record the pulling weight both static and dynamic (**IMPORTANT**).

<i>Depth, ft</i>	<i>RIH weight, lbf</i>	<i>Static weight, lbf</i>	<i>Pick up weight, lbf</i>

89. Upon completion pull test, start pumping nitrogen with 500 scf/min for 30 minutes while monitoring the returns on surface.
- 89.1. If fluid is observed at surface at a good flow rate, continue lifting until all fluid is recovered.
- 89.2. Constantly monitor & record the return from the well and THP. Periodically take fluid sample and verify the salinity.
- 89.3. If there is no fluid return at surface, continue pumping nitrogen and RIH to the next depth as per table below:

Prepared By: Muhd Shahfariz	Reviewed By: Kung Yee Han	Date: 20/6/2023	Rev. Rev.0	Controlled Document DB-CT-MSF-23011	Pg. 34
--------------------------------	------------------------------	--------------------	---------------	----------------------------------------	-----------

<b>DIMENSION BID</b>	<b>DIMENSION BID COILED TUBING SERVICES</b>		 <b>PETRONAS</b>
	ANGSI A-25	SAND CLEANOUT & RE- PERFORATION	

No.	Stage	N2 Rate	Total N2	Duration	Coiled Tubing					
		SCFM	SCF	Minute	ft/min	From (ft)	From (m)	To (ft)	To (m)	Total Footage (ft)
1	RIH	300	10500	35	30	0	0	1050	320	1050
2	Pull Test	300	750	3	20	1050	320	1000	305	50
3	RIH	300	3580	12	30	1000	305	1358	414	358
5	<b>Circulation**</b>	500	15000	30	0	<b>1358</b>	414	<b>1358</b>	414	0
6	RIH	500	16667	33	30	1358	414	2358	719	1000
7	Pull test	500	1250	3	20	2358	719	2308	703	50
8	<b>Circulation</b>	500	15000	30	0	<b>2308</b>	703	<b>2308</b>	703	0
9	RIH	500	16667	33	30	2308	703	3308	1008	1000
10	Pull test	500	1250	3	20	3308	1008	3258	993	50
11	<b>Circulation</b>	500	15000	30	0	<b>3258</b>	993	<b>3258</b>	993	0
12	RIH	500	16667	33	30	3258	993	4258	1298	1000
13	Pull test	500	1250	3	20	4258	1298	4208	1283	50
14	<b>Circulation</b>	500	15000	30	0	<b>4208</b>	1283	<b>4208</b>	1283	0
15	RIH	500	16667	33	30	4208	1283	5208	1587	1000
16	Pull test	500	833	2	30	5208	1587	5158	1572	50
17	<b>Circulation</b>	500	15000	30	30	<b>5158</b>	1572	<b>5158</b>	1572	0
18	RIH	500	16667	33	30	5158	1572	6158	1877	1000
19	Pull test	500	833	2	30	6158	1877	6108	1862	50
20	<b>Circulation</b>	500	15000	30	30	<b>6108</b>	1862	<b>6108</b>	1862	0
21	RIH	500	16667	33	30	6108	1862	7108	2166	1000
22	Pull test	500	833	2	30	7108	2166	7058	2151	50
23	<b>Circulation</b>	500	15000	30	30	<b>7058</b>	2151	<b>7058</b>	2151	0
24	RIH	500	16667	33	30	7058	2151	8058	2456	1000
25	Pull test	500	833	2	30	8058	2456	8008	2441	50
26	<b>Circulation</b>	500	15000	30	30	<b>8008</b>	2441	<b>8008</b>	2441	0
27	RIH	500	16667	33	30	8008	2441	9008	2746	1000
28	Pull test	500	833	2	30	9008	2746	8958	2730	50
29	<b>Circulation</b>	500	15000	30	30	<b>8958</b>	2730	<b>8958</b>	2730	0
30	RIH	500	16667	33	30	8958	2730	9958	3035	1000
31	Pull test	500	833	2	30	9958	3035	9908	3020	50
32	<b>Circulation</b>	500	15000	30	30	<b>9908</b>	3020	<b>9908</b>	3020	0
33	RIH	500	16667	33	30	9908	3020	10908	3325	1000
34	Pull test	500	833	2	30	10908	3325	10858	3309	50
35	<b>Circulation</b>	500	15000	30	30	<b>10858</b>	3309	<b>10858</b>	3309	0
36	RIH	500	16667	33	30	10858	3309	11858	3614	1000
37	Pull test	500	833	2	30	11858	3614	11808	3599	50
38	<b>Circulation</b>	500	15000	30	30	<b>11808</b>	3599	<b>11808</b>	3599	0
39	RIH	500	16667	33	30	11808	3599	12808	3904	1000
40	Pull test	500	833	2	30	12808	3904	12758	3888	50
41	<b>Circulation</b>	500	15000	30	30	<b>12758</b>	3888	<b>12758</b>	3888	0
42	RIH	500	16667	33	30	12758	3888	13758	4193	1000
43	Pull test	500	833	2	30	13758	4193	13708	4178	50
44	<b>Circulation</b>	500	15000	30	30	<b>13708</b>	4178	<b>13708</b>	4178	0
45	RIH	500	12150	24	30	13708	4178	14437	4400	729
46	Pull test	500	833	2	30	14437	4400	14387	4385	50
47	<b>Circulation</b>	500	15000	30	30	<b>14387</b>	4385	<b>14387</b>	4385	0
48	POOH	300	9000	30	30	<b>14387</b>	4385	<b>0</b>	<b>0</b>	14387
		<b>Total N2, SCF</b>	<b>490,563</b>	<b>17 Hours</b>						
		<b>Total N2, Gal</b>	<b>5,268</b>							
		<b>Priming, gal</b>	<b>900</b>							
		<b>Total N2, Gal (including 3% losses)</b>	<b>6,353</b>							

90. Please note the maximum depth of circulation is at **4385m-MDDF**.
91. Stop pumping N2 once get continuous gas return on surface.
92. If oil return at surface and the well able to flow without N2 lifting for 1 hours, proceed POOH to surface.
  - 92.1. In the event that after unloading the well was unsuccessful, consult town for further assistance whether to repeat nitrogen unloading.

Prepared By: Muhd Shahfariz	Reviewed By: Kung Yee Han	Date: 20/6/2023	Rev. Rev.0	Controlled Document DB-CT-MSF-23011	Pg. 35
--------------------------------	------------------------------	--------------------	---------------	----------------------------------------	-----------

<b>DIMENSION BID</b>	DIMENSION BID COILED TUBING SERVICES		
	ANGSI A-25	SAND CLEANOUT & RE- PERFORATION	

93. Upon well commencing to flow satisfactorily, POOH CT to surface.
- 93.1. Pump N2 at minimum permissible rate while POOH. Do not exceed 5,000 psi pumping pressure.
- 93.2. Maximum coil speed while POOH is 50ft/min.
- 93.3. Slow down coil speed to 10ft/min 50ft before and after passing through completion accessories.
- 93.4. Do not exceed CT Operating Limit.
94. Once CT on surface, close well, bleed off pressure in coil and stack up and handover well to PCSB.

Prepared By: Muhd Shahfariz	Reviewed By: Kung Yee Han	Date: 20/6/2023	Rev. Rev.0	Controlled Document DB-CT-MSF-23011	Pg. 36
--------------------------------	------------------------------	--------------------	---------------	----------------------------------------	-----------

<b>DIMENSION BID</b>	DIMENSION BID COILED TUBING SERVICES		
	ANGSI A-25	SAND CLEANOUT & RE- PERFORATION	

**APPENDIX I – BOTTOM HOLE ASSEMBLY SCHEMATIC**

# DIMENSION BID

**BHA DIAGRAM #1 - 2.125" Spincat Nozzle**

<b>Client</b>	Petronas Carigali
<b>Field</b>	Angsi-A25
<b>Job Type</b>	SCO
<b>Job No.</b>	

<b>Well</b>	A25
<b>Min Restriction</b>	2.69"
<b>BHP</b>	
<b>BHT</b>	

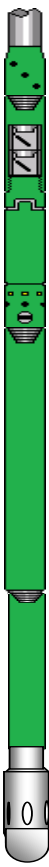
BHA DRAWING	DESCRIPTION	CONNECTION		ID INCH	OD INCH	TOOL LENGTH FT	CUMULATIVE LENGTH FT
		UPHOLE	DOWNHOLE				
	External Dimple CT Connector	1.5" CT	1.5 AMMT		2.125	0.80	0.8
	MHA Disconnect drop ball 3/4" Shear pressure 5,456 psi	1.5 AMMT Box	1.5 AMMT		2.125	2.3	3.1
	Circulating drop ball 5/8" Shear pressure 2,520 psi Burst Disc 5000 psi						
	5 ft Straight Bar	1.5 AMMT Box	1.5 AMMT		2.125	5.0	8.1
	3ft Straight Bar	1.5 AMMT Box	1.5 AMMT		2.125	3.0	11.1
	Spincat Nozzle	1.5 AMMT Box			2.125	1.0	12.1

<b>BHA LENGTH</b>	12.10
<b>MAXIMUM OD</b>	2.125"
<b>MINIMUM ID</b>	

<b>Prepared by:</b>	Muhd Shahfariz
<b>Review by:</b>	
<b>Revision:</b>	
<b>Date:</b>	

<b>ADDITIONAL INFORMATION:</b>

<b>DIMENSION BID</b>	<b>DIMENSION BID COILED TUBING SERVICES</b>		
	ANGSI A-25	SAND CLEANOUT & RE-PERFORATION	



**BHA DIAGRAM #2 GRCCCL c/w Dummy Gun**

Client	Petronas Carigali
Field	Angsi
Job Type	SCO & Re-perf
Job No.	

Well	A25
Min Restriction	2.69"
BHP	
BHT	

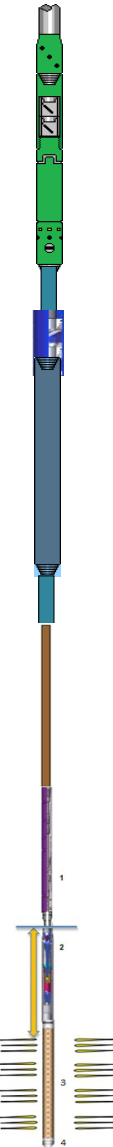
BHA DRAWING	DESCRIPTION	CONNECTION		ID	OD	TOOL LENGTH	CUMULATIVE LENGTH
		UPHOLE	DOWNHOLE				
	External Dimple CT Connector	1.5" CT	1.5" AMMT PIN		2.125	0.6	0.6
	2 1/8 MHA Disconnect drop ball 3/4" Shear pressure 5,456 psi	1.5" AMMT BOX	1.5" AMMT PIN		2.125	2.5	3.1
	Circulating drop ball 5/8" Shear pressure 2,520 psi Burst Disc 5,000 psi						
	Carsac	1.5" AMMT Box	1.5" AMMT PIN		2.13	1.58	4.7
	Dual Ball Kelly Cock Valve	1.5" AMMT Box	1.5" AMMT PIN		2.13	1.58	6.26
	1.5 OD" Deployment Bar	1.5" AMMT Box	1.5" AMMT PIN		2.13	6.000	12.26
	Crossover (DB)	1.5" AMMT Box	1.0" AMMT PIN		2.13	0.5	12.76
	Crossover CRP	1.0" AMMT BOX	1.275" - 12 TPI BOX ACME		1.69	0.33	13.09
	Uzma Firing Head (Drop 0.5" Phenolic)	1.275" - 12 TPI STUB ACME	1.275" - 12 TPI BOX ACME		1.69	0.67	13.76
	2-3/8" 6 SPF 11ft Gun + Top Sub	1.275" - 12 TPI STUB ACME	1.687" - 8 TPI BOX ACME		2.375	11.24	25.00
	Bull Plug SR	1.687" - 8 TPI STUB ACME	1.687" - 8 TPI STUB ACME		2.375	0.26	25.26
	1 1.69" GRCCCL Tool	1.687" - 8 TPI STUB ACME	NIL		2.375	6.17	31.43
	2 3 4						

BHA LENGTH	31.43
MAXIMUM OD	2.375
MINIMUM ID	

Prepared by:	Muhd Shahfariz
Review by:	
Revision:	
Date:	

<b>ADDITIONAL INFORMATION:</b>

<b>DIMENSION BID</b>	<b>DIMENSION BID COILED TUBING SERVICES</b>		
	ANGSI A-25	SAND CLEANOUT & RE-PERFORATION	



**BHA DIAGRAM #3 PERF GUN#1 10m)**

Client	Petronas Carigali
Field	Angsi
Job Type	SCO & Re-perf
Job No.	

Well	A25
Min Restriction	2.69"
BHP	
BHT	

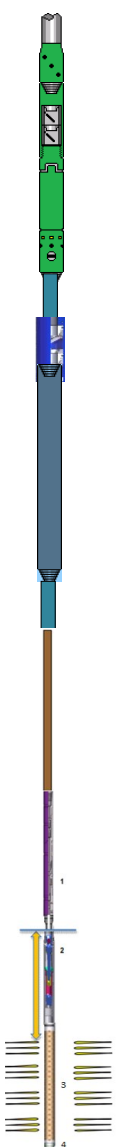
BHA DRAWING	DESCRIPTION	CONNECTION		ID	OD	TOOL LENGTH	CUMULATIVE LENGTH
		UPHOLE	DOWNHOLE				
	External Dimple CT Connector	1.5" CT	1.5" AMMT PIN		2.125	0.6	0.6
	2 1/8 MHA Disconnect drop ball 3/4" Shear pressure 5,456 psi	1.5" AMMT BOX	1.5" AMMT PIN		2.125	2.5	3.1
	Circulating drop ball 5/8" Shear pressure 2,520 psi Burst Disc 5,000 psi						
	Carsac	1.5" AMMT Box	1.5" AMMT PIN		2.13	1.58	4.7
	Dual Ball Kelly Cock Valve	1.5" AMMT Box	1.5" AMMT PIN		2.13	1.58	6.26
	1.5 OD" Deployment Bar	1.5" AMMT Box	1.5" AMMT PIN		2.13	6.000	12.26
	Crossover	1.5" AMMT Box	1.0" AMMT PIN		2.13	0.5	12.76
	Crossover CRP	1.0" AMMT BOX	1.275" - 12 TPI BOX ACME		1.69	0.33	13.09
	Uzma Firing Head (Drop 0.5" Phenolic)	1.275" - 12 TPI STUB ACME	1.275" - 12 TPI BOX ACME		1.69	0.67	13.76
	2-3/8" 6 SPF 11ft Gun + Top Sub	1.275" - 12 TPI STUB ACME	1.687" - 8 TPI BOX ACME		2.375	11.24	25.00
	2-3/8" 6 SPF 11ft Gun + Tandem Sub	1.275" - 12 TPI STUB ACME	1.687" - 8 TPI BOX ACME		2.375	11.24	36.24
	2-3/8" 6 SPF 11ft Gun + Tandem Sub	1.275" - 12 TPI STUB ACME	1.687" - 8 TPI BOX ACME		2.375	11.24	47.48
	Bull Plug	1.687" - 8 TPI BOX ACME	Nil		2.375	0.21	47.69

BHA LENGTH	47.69
MAXIMUM OD	2.375
MINIMUM ID	

Prepared by:	Muhd Shahfariz
Review by:	
Revision:	
Date:	

<b>ADDITIONAL INFORMATION:</b>

<b>DIMENSION BID</b>	<b>DIMENSION BID COILED TUBING SERVICES</b>		
	ANGSI A-25	SAND CLEANOUT & RE-PERFORATION	



**BHA DIAGRAM #4 PERF GUN#2 10m**

<b>Client</b>	Petronas Carigali
<b>Field</b>	Angsi
<b>Job Type</b>	SCO & Re-perf
<b>Job No.</b>	

<b>Well</b>	A25
<b>Min Restriction</b>	2.69"
<b>BHP</b>	
<b>BHT</b>	

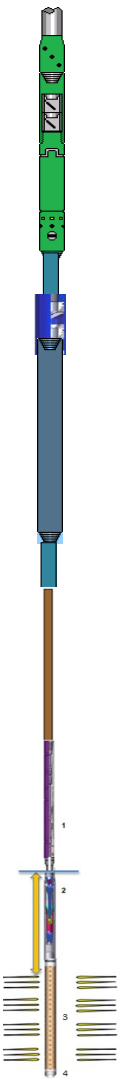
BHA DRAWING	DESCRIPTION	CONNECTION		ID	OD	TOOL LENGTH	CUMULATIVE LENGTH
		UPHOLE	DOWNHOLE				
	External Dimple CT Connector	1.5" CT	1.5" AMMT PIN		2.125	0.6	0.6
	2 1/8 MHA Disconnect drop ball 3/4" Shear pressure 5,456 psi	1.5" AMMT BOX	1.5" AMMT PIN		2.125	2.5	3.1
	Circulating drop ball 5/8" Shear pressure 2,520 psi Burst Disc 5,000 psi						
	Carsac	1.5" AMMT Box	1.5" AMMT PIN		2.13	1.58	4.7
	Dual Ball Kelly Cock Valve	1.5" AMMT Box	1.5" AMMT PIN		2.13	1.58	6.26
	1.5 OD" Deployment Bar	1.5" AMMT Box	1.5" AMMT PIN		2.13	6,000	12.26
	Crossover	1.5" AMMT Box	1.0" AMMT PIN		2.13	0.5	12.76
	Crossover CRP	1.0" AMMT BOX	1.275" - 12 TPI BOX ACME		1.69	0.33	13.09
	Uzma Firing Head (Drop 0.5" Phenolic)	1.275" - 12 TPI STUB ACME	1.275" - 12 TPI BOX ACME		1.69	0.67	13.76
	2-3/8" 6 SPF 11ft Gun + Top Sub	1.275" - 12 TPI STUB ACME	1.687" - 8 TPI BOX ACME		2.375	11.24	25.00
	2-3/8" 6 SPF 11ft Gun + Tandem Sub	1.275" - 12 TPI STUB ACME	1.687" - 8 TPI BOX ACME		2.375	11.24	36.24
	2-3/8" 6 SPF 11ft Gun + Tandem Sub	1.275" - 12 TPI STUB ACME	1.687" - 8 TPI BOX ACME		2.375	11.24	47.48
Bull Plug	1.687" - 8 TPI BOX ACME	Nil		2.375	0.21	47.69	

<b>BHA LENGTH</b>	47.69
<b>MAXIMUM OD</b>	2.375
<b>MINIMUM ID</b>	

<b>Prepared by:</b>	Muhd Shahfariz
<b>Review by:</b>	
<b>Revision:</b>	
<b>Date:</b>	

<b>ADDITIONAL INFORMATION:</b>

<b>DIMENSION BID</b>	DIMENSION BID COILED TUBING SERVICES		
	ANGSI A-25	SAND CLEANOUT & RE- PERFORATION	



**BHA DIAGRAM #1-2-1/8" Upward jetting Nozzle**

<b>Client</b>	Petronas Carigali	<b>Well</b>	A25
<b>Field</b>	Angsi	<b>Min Restriction</b>	2.69"
<b>Job Type</b>	SCO	<b>BHP</b>	
<b>Job No.</b>		<b>BHT</b>	

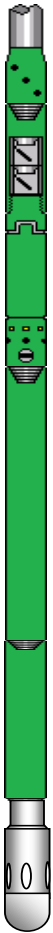
BHA DRAWING	DESCRIPTION	CONNECTION		ID	OD	TOOL LENGTH	CUMULATIVE LENGTH
		UPHOLE	DOWNHOLE				
	External Dimple CT	1.5" CT	1.5" AMMT PIN		2.125	0.6	0.6
	MHA Disconnect drop ball 3/4" Shear pressure 5,456 psi	1.5" AMMT BOX	1.5" AMMT PIN		2.125	2.5	3.1
	Circulating drop ball 5/8" Shear pressure 2,520 psi Burst Disc 5000 psi						
	5 ft Straight Bar	1.5" AMMT BOX	1.5" AMMT PIN		2.125	5.0	8.1
	3 ft Straight Bar	1.5" AMMT BOX	1.5" AMMT PIN		2.125	3.0	11.10
	UpwardJet Nozzle	1.5" AMMT BOX			2.125	0.8	11.9

<b>BHA LENGTH</b>	<b>11.90</b>
<b>MAXIMUM OD</b>	<b>2.125</b>
<b>MINIMUM ID</b>	

<b>Prepared by:</b>	Muhd Shahfariz
<b>Review by:</b>	
<b>Revision:</b>	
<b>Date:</b>	

<b>ADDITIONAL INFORMATION:</b>

<b>DIMENSION BID</b>	DIMENSION BID COILED TUBING SERVICES		
	ANGSI A-25	SAND CLEANOUT & RE- PERFORATION	

**APPENDIX II – COILED TUBING STACK UP**

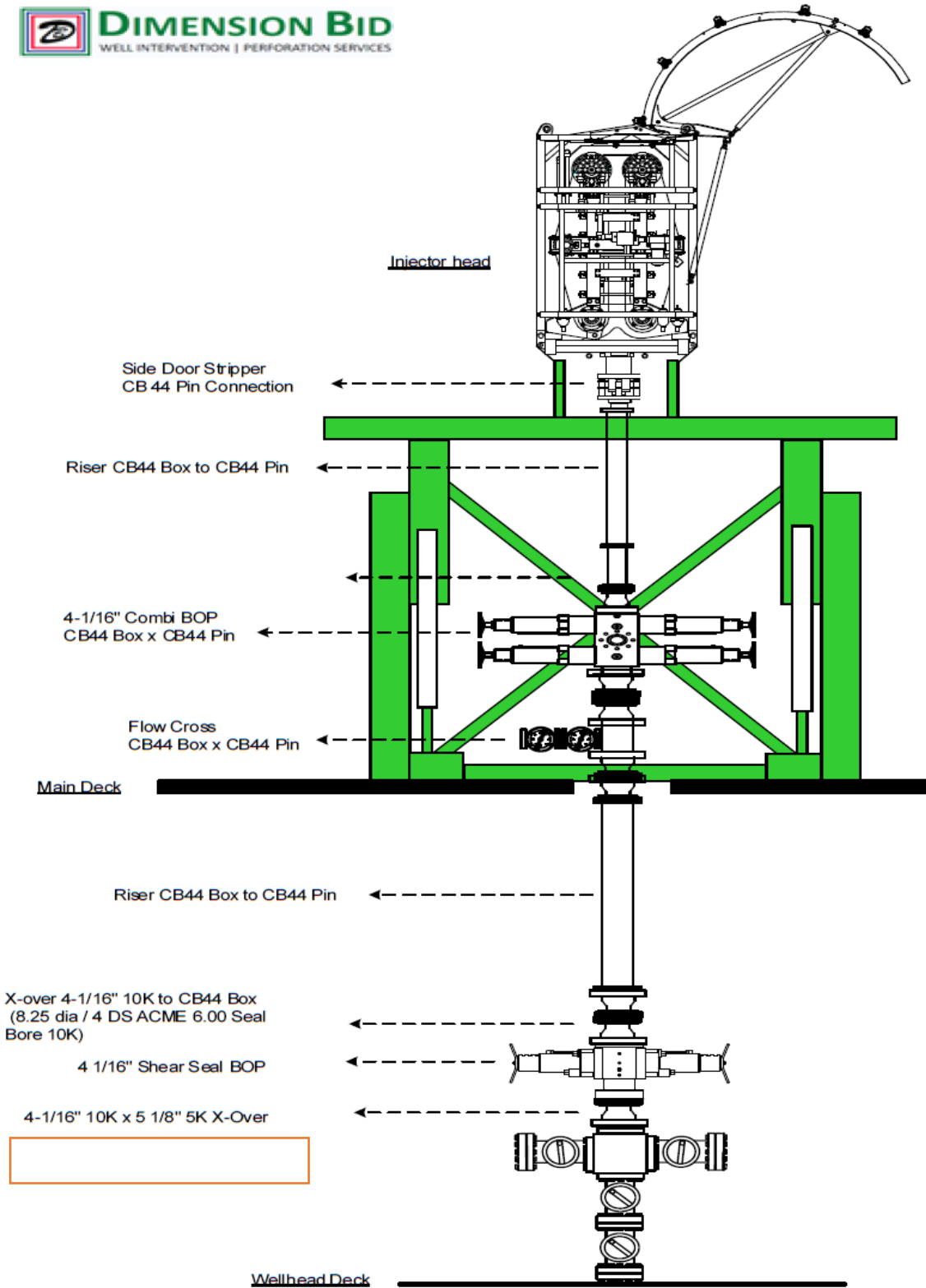

Prepared By: Muhd Shahfariz	Reviewed By: Kung Yee Han	Date: 20/6/2023	Rev. Rev.0	Controlled Document DB-CT-MSF-23011	Pg. 42
--------------------------------	------------------------------	--------------------	---------------	----------------------------------------	-----------

**APPENDIX III – ORPHEUS SIMULATIONS & CIRCA SIMULATION  
LONG STRING**

**TUBING FORCE ANALYSIS ((1<sup>st</sup> Run – 0.8BPM, 400scf/min)**

Calculations at 4913.0 m

MD1 ■ The available pick-up at 4913.0 m based on 80% of yield strength is 10920 lbf.  
The weight indicator reading will then be 34706 lbf.

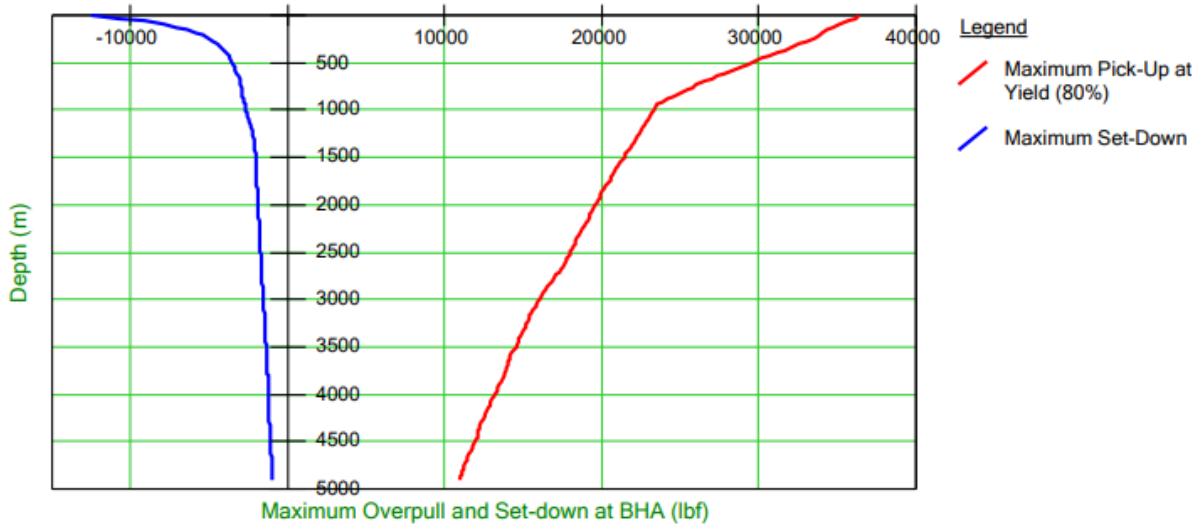

**RIH & POOH WEIGHT**

RIH and POOH

between 0.0 m and 4913.0 m

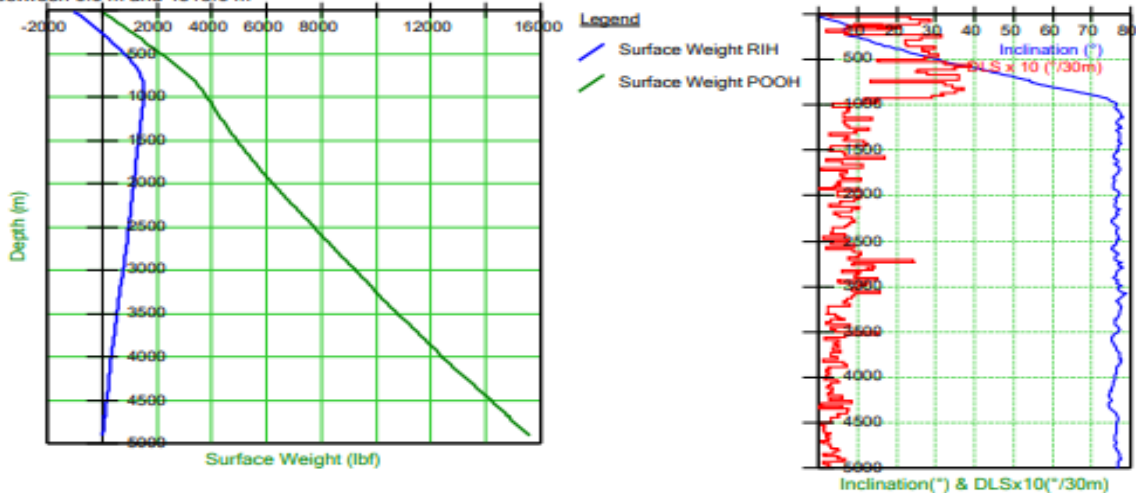

- B1 ■ RIH: CT and BHA can reach the target depth of 4913.0 m.  
 - no lockup detected  
 - pipe yield limit not exceeded  
 - pipe collapse limit not exceeded  
 - BHA stress limit not exceeded  
 - no catastrophic buckling detected
- B2 ■ POOH: CT and BHA can be retrieved to surface from the target depth of 4913.0 m.  
 - pipe yield limit not exceeded  
 - pipe collapse limit not exceeded  
 - BHA stress limit not exceeded

<b>DIMENSION BID</b>	DIMENSION BID COILED TUBING SERVICES		
	ANGSI A-25	SAND CLEANOUT & RE- PERFORATION	

**MAXIMUM STRING SET DOWN LIMIT**

MD3 ■ The available set-down force at 4913.0 m is -974 lbf at the end of the string.  
The weight indicator reading will be -3311 lbf on surface.

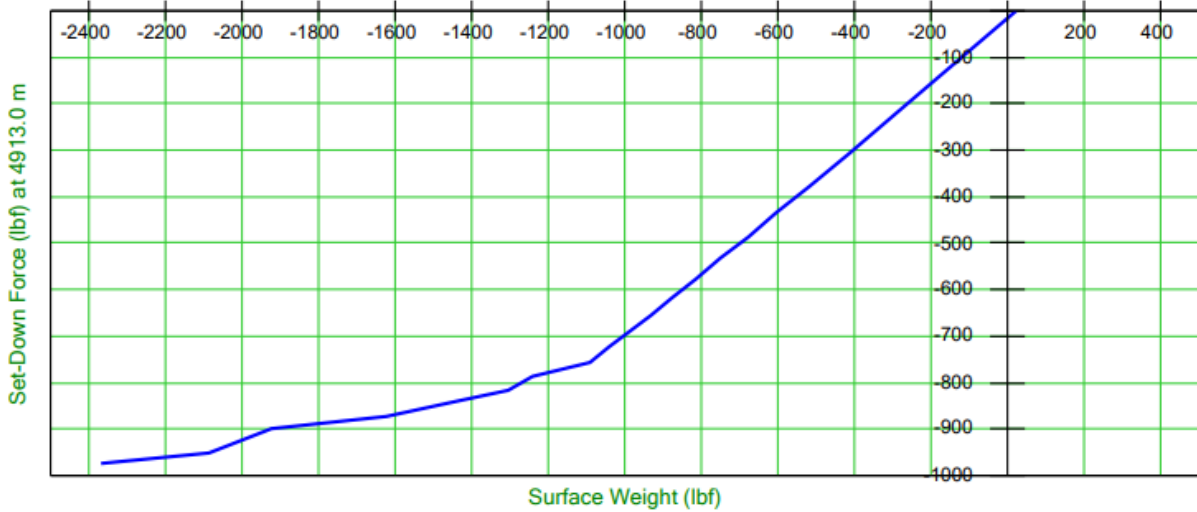

**MAXIMUM STRING PICK UP LIMIT**

Calculations at 4913.0 m

MD1 ■ The available pick-up at 4913.0 m based on 80% of yield strength is 10920 lbf.  
The weight indicator reading will then be 34706 lbf.

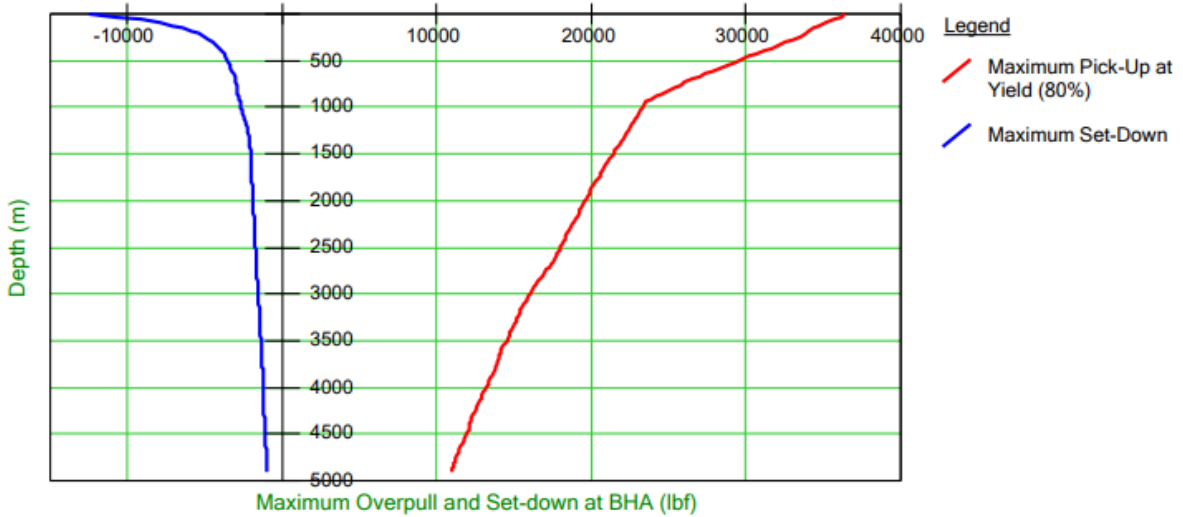

**STRING LIMIT**

CT Limits

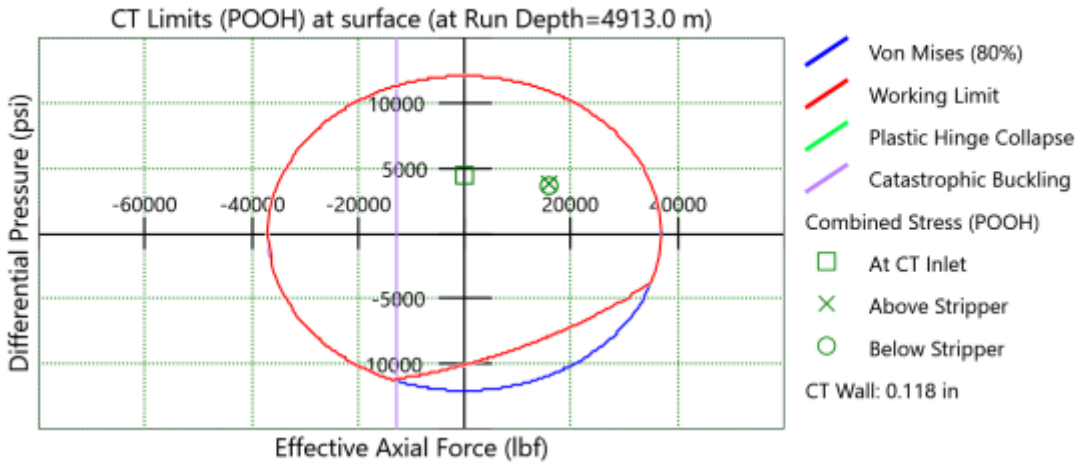
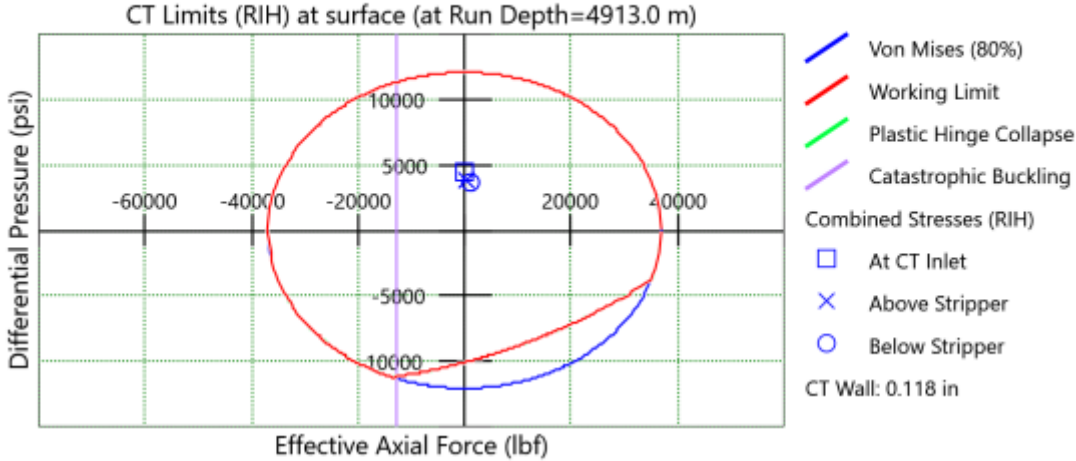

<b>DIMENSION BID</b>	DIMENSION BID COILED TUBING SERVICES		
	ANGSI A-25	SAND CLEANOUT & RE- PERFORATION	

**CIRCA SIMULATION (0.8BPM, 400scfm- 1<sup>st</sup> Section 4664m-4690m-MDDF)**

Ctran Summary

SUMMARY OF HOLE CLEANING RESULTS

Initial Condition:

% of fill interval occupied by solids before cleanout ...	100.0 %
Top of fill .....	4664.11 m
Deepest Circulation point .....	4689.99 m
Bottom of fill .....	4689.99 m
Initial Volume of Solids.....	2.3 bbl
Initial Mass of Solids.....	543.7 kg
Solids type:	Mud Residue/Formation Fines
Fluid Description:	Nitrified Water

Penetration Hole Cleaning Mode:

Penetration rate.....	1.0 ft/min
Penetration time.....	1.42 hr
Solids volume in the well after penetration .....	2.3 bbl
Solids mass in the well after penetration .....	543.7 kg

Circulation Hole Cleaning Mode:

Hole circulation time .....	28.47 hr
Solids volume in the well after circulation.....	0.3 bbl
Solids mass in the well after circulation.....	58.3 kg

Wiper Trip Hole Cleaning Mode:

Wiper Trip Scheme:	User Specified rate, Tornado not
Wiper trip time .....	0.15 hr
Solids volume in the well after wiper trip .....	0.3 bbl
Solids mass in the well after wiper trip .....	58.3 kg

Volume of Fluids Pumped During Penetration, Circulation & Wiper Trip:

Gas volume .....	721014.5 scf
Liquid Volume .....	1442.0 bbl
Penetration, Circulation & Wiper Trip time .....	30.04 hr

Circulation results at point of Maximum Solids Head:

<b>DIMENSION BID</b>	DIMENSION BID COILED TUBING SERVICES		
	ANGSI A-25	SAND CLEANOUT & RE- PERFORATION	

**CIRCA SIMULATION (0.8BPM, 400scfm- 2<sup>nd</sup> Section 4690m – 4707.5m-MDDF)**

Ctran Summary

SUMMARY OF HOLE CLEANING RESULTS

Initial Condition:

% of fill interval occupied by solids before cleanout ...	100.0 %
Top of fill .....	4689.99 m
Deepest Circulation point .....	4707.51 m
Bottom of fill .....	4707.51 m
Initial Volume of Solids.....	2.3 bbl
Initial Mass of Solids.....	525.4 kg
Solids type:	Mud Residue/Formation Fines
Fluid Description:	Nitrified Water

Penetration Hole Cleaning Mode:

Penetration rate.....	1.0 ft/min
Penetration time.....	0.96 hr
Solids volume in the well after penetration .....	2.3 bbl
Solids mass in the well after penetration .....	525.4 kg

Circulation Hole Cleaning Mode:

Hole circulation time .....	38.14 hr
Solids volume in the well after circulation.....	0.6 bbl
Solids mass in the well after circulation.....	132.6 kg

Wiper Trip Hole Cleaning Mode:

Wiper Trip Scheme:	User Specified rate, Tomado not
Wiper trip time .....	0.17 hr
Solids volume in the well after wiper trip .....	0.6 bbl
Solids mass in the well after wiper trip .....	132.6 kg

Volume of Fluids Pumped During Penetration, Circulation & Wiper Trip:

Gas volume .....	942405.0 scf
Liquid Volume .....	1884.8 bbl
Penetration, Circulation & Wiper Trip time .....	39.27 hr

Circulation results at point of Maximum Solids Head:

Prepared By: Muhd Shahfariz	Reviewed By: Kung Yee Han	Date: 20/6/2023	Rev. Rev.0	Controlled Document DB-CT-MSF-23011	Pg. 47
--------------------------------	------------------------------	--------------------	---------------	----------------------------------------	-----------

<b>DIMENSION BID</b>	DIMENSION BID COILED TUBING SERVICES		
	ANGSI A-25	SAND CLEANOUT & RE- PERFORATION	

**CIRCA SIMULATION (0.8BPM, 400scfm- 3<sup>rd</sup> Section 4707.5m – 4725m-MDDF)**

Ctran Summary

SUMMARY OF HOLE CLEANING RESULTS

Initial Condition:

% of fill interval occupied by solids before cleanout ...	100.0 %
Top of fill .....	4707.51 m
Deepest Circulation point .....	4725.01 m
Bottom of fill .....	4725.01 m
Initial Volume of Solids.....	2.3 bbl
Initial Mass of Solids.....	525.4 kg
Solids type:	Mud Residue/Formation Fines
Fluid Description:	Nitrified Water

Penetration Hole Cleaning Mode:

Penetration rate.....	1.0 ft/min
Penetration time.....	0.98 hr
Solids volume in the well after penetration .....	2.3 bbl
Solids mass in the well after penetration .....	525.4 kg

Circulation Hole Cleaning Mode:

Hole circulation time .....	50.00 hr
Solids volume in the well after circulation.....	1.1 bbl
Solids mass in the well after circulation.....	248.7 kg

Wiper Trip Hole Cleaning Mode:

Wiper Trip Scheme:	User Specified rate, Tornado not
Wiper trip time .....	1.87 hr
Solids volume in the well after wiper trip .....	0.9 bbl
Solids mass in the well after wiper trip .....	218.8 kg

Volume of Fluids Pumped During Penetration, Circulation & Wiper Trip:

Gas volume .....	1267921.5 scf
Liquid Volume .....	2535.8 bbl
Penetration, Circulation & Wiper Trip time .....	52.83 hr

Circulation results at point of Maximum Solids Head:

Prepared By: Muhd Shahfariz	Reviewed By: Kung Yee Han	Date: 20/6/2023	Rev. Rev.0	Controlled Document DB-CT-MSF-23011	Pg. 48
--------------------------------	------------------------------	--------------------	---------------	----------------------------------------	-----------

<b>DIMENSION BID</b>	DIMENSION BID COILED TUBING SERVICES		
	ANGSI A-25	SAND CLEANOUT & RE- PERFORATION	

## APPENDIX IV – EMERGENCY PROCEDURE EMERGENCY BOP OPERATIONS

In the event of an emergency arising and the well having to be secured, the following steps should be taken:

1. Stop Coiled Tubing movement, close the Slip and Pipe rams and slack off string weight to ensure slips are holding. If time permits, review all options with the client representative. (Ensure that rams with guides are activated first to avoid damaging the Coiled Tubing).

**Note: The decision to proceed past the above step should normally be made after consultation with the client representative unless there is an immediate and serious danger to personnel and/or equipment and the client representative is not immediately available to be involved in the decision.**

2. Stop pumping.
3. Close the upper Shear Seal rams to cut the Coiled Tubing.
4. Set up to circulate well to kill fluid through the Coiled Tubing remaining in the well.
5. Make arrangements necessary to fish the Coiled Tubing from the BOP.

**Note: When actuating any ram in the BOP system, the corresponding manual lock should be closed behind it to prevent accidental release in the event of total loss of hydraulic power. The force required to close the rams manually against pressure cannot be supplied by turning in the locks. Use of a pipe wrench, cheater bars or snipes will damage the internal workings of the ram actuators. Some form of hydraulic power is required to operate the actuators. This pressure can be supplied via a hand pump or a hydraulic pump from any other piece of equipment on location, including a fluid pumper.**

### Actuating the BOP System Hydraulic Controls

1. Remove locks on control panel
2. Move the control lever to the desired position.
3. Push the BOP activate button supplying pressure to the circuit.
4. Observe the pressure drop in the hydraulic circuit and subsequent pressuring back up to system pressure as ram opens or closes completely.
5. Observe the ram indicator pins to verify the operation of the ram.
6. Close in the manual locks if required. (Flag system to indicate position of rams.)

The connections below the coiled tubing BOP must be all flanged. Should one of these connections start leaking, the following steps should be taken in consultation with the client representative:

1. Call local alert and ensure all personnel are removed from the wellhead area.
2. Notify the client representative of the problem and determine the best method to make the area safe.
3. If the leak is minor, it may be possible to continue to pull the coiled tubing to surface. Assess the scenario and consider all the risks associated then proceed to pull the coiled tubing to surface. Once at surface, close available valves below the leak point.
4. If the leak is more severe, initiate a well kill through the well kill line and continue to pull the coiled tubing to surface.
5. If the leak is catastrophic, run the coiled tubing to HUD; pick up sufficient so that after the coiled tubing is cut at surface by CT BOP shear; the top of the coiled tubing falls below the X-mass Tree. Once the end of the coiled tubing is off bottom, proceed to cut the coiled tubing with the shear RAM then close the available valves below the leak point. A well kill operation can be started through the kill line if requested by the client representative.

Prepared By: Muhd Shahfariz	Reviewed By: Kung Yee Han	Date: 20/6/2023	Rev. Rev.0	Controlled Document DB-CT-MSF-23011	Pg. 49
--------------------------------	------------------------------	--------------------	---------------	----------------------------------------	-----------

<b>DIMENSION BID</b>	DIMENSION BID COILED TUBING SERVICES		
	ANGSI A-25	SAND CLEANOUT & RE- PERFORATION	

## LEAK IN COILED TUBING AT SURFACE

In the event of a leak in the Coiled Tubing occurring at surface, the following steps should be taken:

1. Call local alert and ensure all personnel are removed from the operational area. In particular make sure all personnel remain clear of the area between the Injector Head and the Coiled Tubing reel.
2. If the leak is small or a pinhole leak, POOH and position the leak on the lower part of the Coiled Tubing reel as soon as possible. Be careful when area of leak is bent onto the reel as failure may occur. Make arrangements to have a water hose present to wash away any fluid from the reel which may be hazardous. Make arrangements to start pumping water through the Coiled Tubing reel. Depressurize reel as much as conditions allow without exceeding collapse limitations of Coiled Tubing.
3. Notify client representative of problem and determine best method to make area safe. If leak is minor and water can be displaced to leak, continue to POOH and change reel.
4. If leak is considered to be too serious to displace to water and POOH, or serious and uncontrolled leakage of hydrocarbon or hazardous materials prevents this, (i.e. check valves not holding, lost BHA, parted Coiled Tubing) set the Coiled Tubing slips and pipe rams. Activate the upper Shear Seal rams on either the triple or quad BOP and manually lock in place.
5. Depressurize the Coiled Tubing reel and flush through the reel. If hydrocarbons are present in the reel, displace the reel with water and empty the contents to specified safe disposal area.

## LEAK IN COILED TUBING BELOW SURFACE

If a leak occurs in the Coiled Tubing below the Stuffing Box during down hole operations (usually indicated by a drop in pump pressure or loss of string weight), suspend Coiled Tubing operations and alert the client representative.

**Note:**

**If indications are that the BHA has been lost in hole then revert to section 0.**

1. Once the client representative has been alerted, clear all personnel from the immediate area of the Coiled Tubing around the Injector Head and between the Injector Head and the Coiled Tubing reel.
2. Displace the Coiled Tubing to water and commence to POOH at not more than 20 ft per minute (5 meters/min). Ensure at all times that all personnel are clear of the immediate area as the possibility exists to pull the Coiled Tubing out of the Stuffing Box. Continue pumping water at a slow rate through the Coiled Tubing.
3. When the leak in the Coiled Tubing appears above the Stuffing Box, stop the injector and hold the leaking section of Coiled Tubing between the chains and the Stuffing Box.
4. Inspect leak. If leak is minor continue to POOH.
5. If leak is major, or Coiled Tubing is actually severed or well bore fluids are escaping through the Coiled Tubing, continue as per Section 09.2.

Prepared By: Muhd Shahfariz	Reviewed By: Kung Yee Han	Date: 20/6/2023	Rev. Rev.0	Controlled Document DB-CT-MSF-23011	Pg. 50
--------------------------------	------------------------------	--------------------	---------------	----------------------------------------	-----------

<b>DIMENSION BID</b>	DIMENSION BID COILED TUBING SERVICES		
	ANGSI A-25	SAND CLEANOUT & RE- PERFORATION	

## LEAK IN SURFACE PRESSURE CONTROL EQUIPMENT

### Stuffing Box

1. **Stop** Coiled Tubing movement and close both sets of pipe rams to seal Coiled Tubing annulus. Set manual lock.
2. On semi submersible operations this will be a set of pipe rams and pipe/slip rams.
3. Notify Client representative.
4. Ensure the injector is in neutral and that the brake is engaged.
5. Bleed off pressure above pipe rams
6. Set reel brake. On Semi Submersible jobs the Coiled Tubing should be clamped at the level wind and Coiled Tubing run out of hole until enough slack between the injector and reel is obtained to cope with the heave from the rig, prior to setting reel brake.
7. Bleed off closing pressure on Stuffing Box. Open side doors and apply pressure to retract piston. Replace packer elements and then re-apply pressure to Stuffing Box. Close side doors.

**Note: 3" side door Stuffing Boxes first bleed off closing pressure. Remove hoses from pack and retract piston and connect to open and close on side door. Open door and replace packer element. Close door, bleed off pressure and connect to pack and retract piston.**

8. Slowly open both equalizing valve on pipe rams and check that stripper is holding pressure.
9. If stripper is holding pressure, undo manual locks and open pipe rams or pipe slip rams. When using pipe/slip rams the depth that they were set on the Coiled Tubing must be recorded. Release reel brake and continue operations.

### Surface Leaks Other Than Stuffing Box

1. If leak is minor and a relatively short length of Coiled Tubing is in the hole and the Shear Seal safety head is **below the leak**:
2. Call local alert and notify the client representative.
3. Clear all non-essential personnel away from the area
4. Continue POOH and monitor situation closely
5. Hook up kill line to BOP and pump water slowly down annulus.

### **Note: Avoid collapse situation**

1. Close swab valve and Shear Seal once Coiled Tubing is in riser and repair leak
2. Perform reinstatement test on surface equipment after leak has been repaired
3. If Coiled Tubing is in the well to a considerable depth and leak is considered serious:
4. Call local alert and notify Client representative.
5. Ensure all non-essential personnel are removed from the area.
6. Ensure that Coiled Tubing is sufficiently off bottom so that when the Shear Seal safety head is activated the pipe will drop below the Xmas tree manual master valve. If the Coiled Tubing is stuck down hole, pull to 80% of operating limit before activating Shear Seal BOP, thus allowing the Coiled Tubing to drop below the Xmas tree manual master valve. If the Coiled Tubing is attached to a fish, packer etc pull to 80% of operating limit (if possible) or maximum weight possible before activating Shear Seal BOP, thus allowing the Coiled Tubing to drop below the Xmas tree manual master valve. **If at all possible**, the decision to cut the Coiled Tubing and activate the system will be taken by the Client representative in charge of the operation. This may not always be possible. If the situation is extremely dangerous and requires a fast decision, the Supervisor in charge will take this decision.

Prepared By: Muhd Shahfariz	Reviewed By: Kung Yee Han	Date: 20/6/2023	Rev. Rev.0	Controlled Document DB-CT-MSF-23011	Pg. 51
--------------------------------	------------------------------	--------------------	---------------	----------------------------------------	-----------

<b>DIMENSION BID</b>	DIMENSION BID COILED TUBING SERVICES		
	ANGSI A-25	SAND CLEANOUT & RE- PERFORATION	

7. Close the Shear Seal rams in the safety head to cut the pipe and allow it to drop. (If the safety head has separate shear and blind rams, close the shear rams to cut the pipe, pull up the Coiled Tubing and close the blind rams).
8. Close the swab valve on the Xmas tree.
9. Close the master valve on the Xmas tree
10. Repair leak and pressure test riser.
11. Plan for fishing operations.

#### Rotating Joint Leak

Eliminate the potential for reel movement by securing the reel with turnbuckles and set reel brake. On Semi-Submersible jobs the Coiled Tubing should be clamped at the level wind and Coiled Tubing run out of hole until enough slack between the injector and reel is obtained to cope with the heave from the rig. Close the reel isolation valve inside the reel and repair or replace the rotating joint as required. Re-test and resume operations.

### COILED TUBING RUNS AWAY INTO WELL

If the inside chain tension system on the Injector Head should fail for any reason, and Coiled Tubing is pulled into the well under its own weight with no control, the procedure should be as per the following:

1. Call a local alert.
2. Attempt to speed the injector up to match the speed of the descending Coiled Tubing.
3. Increase inside chain tension to increase friction on Coiled Tubing.
4. Increase stripper pressure to exert more friction on Coiled Tubing.
5. If these actions fail to make any difference, reduce injector hydraulic pressure to zero.
6. In the event that there is insufficient Coiled Tubing on the reel to reach bottom close Coiled Tubing slips. This action may damage or break the Coiled Tubing. This is the preferred option to using the pipe rams as these will become damaged and a primary well control system will be lost.
7. If the Coiled Tubing is not too far off bottom it may be practical to let it fall to bottom then investigate the causes and repair. This can only be done if there is sufficient Coiled Tubing on the reel to reach bottom.

**Note: Coiled Tubing may helix when hitting bottom making it difficult to pull into tail pipe.**

8. Once Coiled Tubing has been controlled, examine Injector Head for damage including chains and POOH.
9. The Coiled Tubing run away may be caused by the injector becoming overloaded with the weight of the Coiled Tubing and fluid in the Coiled Tubing. This situation should not occur if proper pre job planning is done. Correct selection of Injector Head or ensuring Coiled Tubing is full of Nitrogen would prevent this situation from occurring.
10. If a run away situation occurs, reduce the injector hydraulic pressure to zero. This may cause the safety brake in the motors to actuate and counter balance valves to close, stopping the injector.
11. Under certain circumstances if the run away Coiled Tubing is at a speed above the critical speed, the back pressure created by the circulating hydraulic fluid may prevent the injector motor brakes from actuating. If this situation occurs, select the pull mode for the injector and increase system hydraulic pressure until the Coiled Tubing comes to a standstill.

Prepared By: Muhd Shahfariz	Reviewed By: Kung Yee Han	Date: 20/6/2023	Rev. Rev.0	Controlled Document DB-CT-MSF-23011	Pg. 52
--------------------------------	------------------------------	--------------------	---------------	----------------------------------------	-----------

<b>DIMENSION BID</b>	DIMENSION BID COILED TUBING SERVICES		
	ANGSI A-25	SAND CLEANOUT & RE- PERFORATION	

## COILED TUBING IS PULLED OUT OF STUFFING BOX

This situation is most likely to occur when the Coiled Tubing is being pulled into the riser section. If the BHA is lost including the End Connector there will be no external upset to prevent the Coiled Tubing from passing through the Stuffing Box. If this situation occurs, stop injector before Coiled Tubing passes through the chains and shut in Shear Seal rams on upper BOP's.

If it is thought that the BHA may be lost while down hole, stop the Coiled Tubing at 300ft from surface. Slowly close in the swab valve counting the number of turns. If the Coiled Tubing is still deemed to be across the wellhead, POOH the Coiled Tubing no more than the distance between the top of the wellhead and the top of the Coiled Tubing BOP's. Repeat this step until the swab valve can be fully shut. Once the swab valve is shut, bleed off the pressure in riser.

## COILED TUBING COLLAPSED AT SURFACE

Collapsed Coiled Tubing at surface will be obvious by escape of well bore fluids from the Stuffing Box, as the strippers will no longer seal round the deformed pipe. In addition to this the collapsed pipe will not allow the Injector Head to grip the Coiled Tubing due to its change in shape. Usually collapsed Coiled Tubing will not pull through the bottom brass bushings on the Stuffing Box.

1. If POOH, immediately run Coiled Tubing back in well a sufficient distance to make sure round pipe is in contact with the Stuffing Box.
2. Call alert and notify client representative.
3. Ensure that all non-essential personnel are cleared from the immediate area.
4. Immediately reduce well head pressure by all safe means possible; either flow well through choke at a higher rate or stop annular fluid injection if reverse circulating.
5. Increase Coiled Tubing internal pressure by circulating.
6. Once pressure conditions inside and outside the Coiled Tubing have been optimized, a decision can be taken on how to proceed. If it is not possible to position uncollapsed pipe across the stripper rubbers, i.e. well contents are escaping from stripper rubbers:
7. Call alert and notify client representative.
8. Close pipe rams in an effort to reduce flow of fluid/gas around Coiled Tubing.

**Note: If it is not possible to control the well, the slips will have to be set, and the Coiled Tubing cut using the Shear Seal rams.**

9. Arrange for clamps to be fitted to Coiled Tubing above Injector Head.
10. Remove all non-essential personnel from immediate area
11. Under authority from client representative, kill well.
12. Release pressure from Stuffing Box and remove bushings.
13. Open pipe rams.
14. Attempt to pull Coiled Tubing from the well using the Injector Head.
15. Cut Coiled Tubing at the gooseneck and use the rig or a crane to pull the Coiled Tubing through the injector. Re-clamp the Coiled Tubing above the Injector Head and cut off in thirty foot sections (or as appropriate to the crane or rig)
16. Continue pulling and cutting Coiled Tubing until the Coiled Tubing pulled to surface can be pulled by the Injector Head.

Prepared By: Muhd Shahfariz	Reviewed By: Kung Yee Han	Date: 20/6/2023	Rev. Rev.0	Controlled Document DB-CT-MSF-23011	Pg. 53
--------------------------------	------------------------------	--------------------	---------------	----------------------------------------	-----------

<b>DIMENSION BID</b>	DIMENSION BID COILED TUBING SERVICES		
	ANGSI A-25	SAND CLEANOUT & RE- PERFORATION	

17. Once Coiled Tubing in good condition (i.e. not collapsed) is at surface, set Coiled Tubing slips and pipe rams and make up roll-on connector to Coiled Tubing on reel.

18. Continue POOH.

If the leak is too serious and cannot be controlled and well fluids are escaping, continue as per Section 9.2.

### COILED TUBING BREAKS AT SURFACE

If Coiled Tubing breaks at surface into two separate sections:

1. Stop the injector and set the slips.
2. Stop pumping operations.
3. Call alert and notify client representative. Ensure all non-essential personnel are cleared from the area and that the area is secure.
4. Secure Coiled Tubing reel.
5. If the reel capacity is insufficient to hold all of the Coiled Tubing remaining in the well due to uneven spooling resulting from the Coiled Tubing failure, it may be necessary to obtain another reel with sufficient capacity to hold the Coiled Tubing remaining in the well.
6. After consulting with client representative, remove damaged section of Coiled Tubing and insert in line roll-on connector and continue to POOH.
7. If this course of action is considered inappropriate or dangerous due to well conditions or condition of Coiled Tubing still in the well, continue as per Section 0.

### BUCKLED TUBING

Should the Coiled Tubing hit an obstruction down hole while RIH with the thrust pressure set too high or running speed too fast, the Coiled Tubing will buckle in a 'Z' shape (plastically hinged).

Coiled Tubing being run inside Coiled Tubing and through small ID BOP's/lubricators will normally buckle between the Stuffing Box and the chains.

Coiled Tubing being run through casing or open hole will normally break below the BOP, usually somewhere around the largest ID.

- The Coiled Tubing will generally buckle several times.
- This type of failure is a little more difficult to detect.

If the Coiled Tubing is being run into casing and a large amount of weight is lost suddenly, there is a very good possibility that the Coiled Tubing is buckled somewhere down hole. Indications of this could be:

- An increase in pump pressure as fluid or gas is now being pushed through an additional restriction created by a hinge.
- A decrease in pump pressure as the Coiled Tubing may have broken removing a restriction such as a BHA.
- A loss of string weight due to the Coiled Tubing breaking and falling off.
- An increase in string weight while pulling out of the hole as the buckled portion of Coiled Tubing creates additional drag or needs to be straightened to get through a restricted ID.

In the event Coiled Tubing buckling is suspected, the Coiled Tubing movement should be stopped and the pump pressure kept within operating limits allowing the situation to be analyzed and determine the correct action to be taken for existing conditions.

**If there is an increase in pump pressure or an increase in string weight:**

Prepared By: Muhd Shahfariz	Reviewed By: Kung Yee Han	Date: 20/6/2023	Rev. Rev.0	Controlled Document DB-CT-MSF-23011	Pg. 54
--------------------------------	------------------------------	--------------------	---------------	----------------------------------------	-----------

<b>DIMENSION BID</b>	DIMENSION BID COILED TUBING SERVICES		
	ANGSI A-25	SAND CLEANOUT & RE- PERFORATION	

1. Stop the pumps and pick up slowly.
2. POOH slowly (10 to 20 feet per minute) watching the weight indicator carefully.
3. If the Coiled Tubing is buckled close to surface, the buckled Coiled Tubing will pull into the bottom of the Stuffing Box and stop.
4. Close and lock the slip and pipe rams.
5. If the ram indicators show that the rams are not completely closed, there may be more than one piece of Coiled Tubing inside the BOP. In this event, open the rams and try to put undamaged Coiled Tubing across the pipe and slip rams.
6. Make arrangements to kill the well and retrieve the remaining Coiled Tubing from the well.
7. If the buckled Coiled Tubing is down hole and cannot be pulled free, consult the client representative as he may want the Coiled Tubing left at TD prior to being hung off in the slip and Coiled Tubing rams.
8. Arrangements should be made to run Coiled Tubing cutter on wireline to retrieve the Coiled Tubing above stuck point.

**If there is a decrease in pump pressure or a loss of string weight:**

1. It must be assumed that the Coiled Tubing has parted somewhere down hole.
2. Calculate from the remaining string weight approximately how much Coiled Tubing is left in the well.
3. Stop the pumps and POOH slowly.
4. Should the Coiled Tubing come out of the Stuffing Box, the blind rams should also be closed in.

**If the Coiled Tubing is buckled above the Stuffing Box, the following steps should be taken:**

1. Stop the injector as quickly as possible.
2. Close the slip and pipe rams and manually lock them.
3. If the down hole check valves are holding, bleed the pressure in the Coiled Tubing down to zero and monitor for 15 minutes for pressure build up.
4. Consider at this stage whether to kill the well.
5. Use a hacksaw to start the cut until you are sure there is no trapped pressure in the Coiled Tubing.
6. Cut the Coiled Tubing
7. Remove as much of the buckled Coiled Tubing as possible leaving any undamaged Coiled Tubing showing above the Stuffing Box intact so that it may be rejoined later.
8. Bleed the pressure from above the Coiled Tubing rams and undo the connection below the injector.
9. Slowly raise the injector until it is clear of the damaged Coiled Tubing.
10. Cut away any damaged Coiled Tubing, dress the Coiled Tubing and install an inline connector.
11. Run some fresh Coiled Tubing down through the injector until it is just out of the Stuffing Box.
12. Lower the injector until immediately over the pipe sticking out of the BOP.
13. Attach the pipe to the inline connection attached to the pipe sticking up out of BOP.
14. Pump off the inside chain tension and rotate the chains slowly in the OOH direction, while lowering the injector until the connection below the injector can be fastened.
15. Pump up the inside chain tension and pull weight equal to the weight of the Coiled Tubing suspended below the slips plus 2,000 lbf for friction or CERBERUS prediction, whichever is greatest.
16. Equalize the pressure across the Coiled Tubing rams.
17. Unlock the pipe and slip rams.

Prepared By: Muhd Shahfariz	Reviewed By: Kung Yee Han	Date: 20/6/2023	Rev. Rev.0	Controlled Document DB-CT-MSF-23011	Pg. 55
--------------------------------	------------------------------	--------------------	---------------	----------------------------------------	-----------

<b>DIMENSION BID</b>	DIMENSION BID COILED TUBING SERVICES		
	ANGSI A-25	SAND CLEANOUT & RE- PERFORATION	

18. Open the slip and pipe rams and POOH.

19. If the down hole check valves do not hold then the Coiled Tubing will have to be cut.

## COILED TUBING STUCK IN HOLE PROCEDURES

There are various scenarios by which Coiled Tubing can be deemed as a stuck in hole situation. The following procedures are to be used as generic guidelines prior to the compilation of a signed off chemical cutting program applicable to the current situation.

In the event of being stuck in hole, several factors would have to be taken into consideration, the first of which would be whether the Coiled Tubing is stuck in hole on a platform, or a semi-submersible, as the procedures to be followed may vary greatly between the two options.

Other factors to be considered are:

- Type of well, i.e. flowing oil or gas well, water injector etc.
- The type of BHA being used, i.e. perforating guns, milling assembly, plug etc.
- The type of operation being carried out when the Coiled Tubing became stuck.

In all of the above cases, the Coiled Tubing would be defined as being “stuck” when the pipe cannot be retrieved from the well bore without the pipe exceeding its 80% minimum yield rating, or without exceeding 80% stress of the weak link release rating. The lower of these two factors should always be used when attempting large pulls.

Regardless of the specifics involved, the following procedures should be adopted:

1. Inform the client representative of the situation.
2. Inform the Onshore Engineer.
3. From the information available, and taking into account the well conditions, try to determine the reason for the pipe/BHA being stuck.
4. Attempt to pull free by applying a steady pull to a maximum of 80% of the Coiled Tubing yield. If in doubt as to what this figure is, consult Engineering Department before proceeding.
5. When applying the maximum pull, hold the maximum value for a minimum of 10 minutes and observe the trend (if any) on the weight indicator and chart. Measure the amount of pipe extension that is required when this pull is applied. The figure can be used to determine where the Coiled Tubing is stuck. As a rule of thumb, the depth that the pipe is held at will be the extension of the Coiled Tubing (in feet) when pulled to 80% of yield divided by 0.002. This can be determined using CERBERUS.

The following are options that may be appropriate depending on the particular circumstances:

1. If possible, flow the well, or increase well flow in an effort to remove debris in the well bore that may be holding the Coiled Tubing/BHA. Maintain maximum circulation through the Coiled Tubing at the same time. This is particularly relevant if well cleanout or drilling operations have been performed.
2. Circulate acid across the BHA in an attempt to remove any acid soluble material that may be holding the Coiled Tubing.
3. Pump fluid down the backside of the Coiled Tubing to the formation in an attempt to dislodge debris from around the BHA. Potential Coiled Tubing collapse must be considered if engineering this scenario.
4. Displace Coiled Tubing contents to a lighter fluid (base oil) or gas (Nitrogen) to increase buoyancy and allow greater end force to be applied at BHA.
5. Underbalance the well in the case of differentially stuck Coiled Tubing.
6. Cool the well if the Coiled Tubing is helically stuck in corkscrewed Production Tubing.

Prepared By: Muhd Shahfariz	Reviewed By: Kung Yee Han	Date: 20/6/2023	Rev. Rev.0	Controlled Document DB-CT-MSF-23011	Pg. 56
--------------------------------	------------------------------	--------------------	---------------	----------------------------------------	-----------

<b>DIMENSION BID</b>	DIMENSION BID COILED TUBING SERVICES		
	ANGSI A-25	SAND CLEANOUT & RE- PERFORATION	

7. Pump down the Coiled Tubing / completion annulus to try and move the source of hold-up.
8. Displace slugs of Nitrogen with water to create a surge effect at the BHA.
9. Pump friction reducer, IM Lube in seawater at 2-3% by volume, down the Coiled Tubing and into the well. Ideally, one well volume will be pumped.
10. After consultation with the client representative and the on call Engineer, activate the emergency disconnect mechanism in the BHA to allow the Coiled Tubing to be released. The release mechanism should only be implemented after all avenues have been explored.
11. When attempting maximum pull, do not work the Coiled Tubing violently across the gooseneck by frequent intervals.
12. The amount of cycles across the gooseneck must be logged, and if in doubt of the Coiled Tubing fatigue condition, the Engineer must be consulted and the cycles entered into the CERBERUS FATIGUE program, to determine the amount of cycles left available.

After consultation with the client representative, kill the well and commence preparations for chemical cutting operations.

Prepared By: Muhd Shahfariz	Reviewed By: Kung Yee Han	Date: 20/6/2023	Rev. Rev.0	Controlled Document DB-CT-MSF-23011	Pg. 57
--------------------------------	------------------------------	--------------------	---------------	----------------------------------------	-----------

**STUCK CT COIL RECOVERY PROCESS**

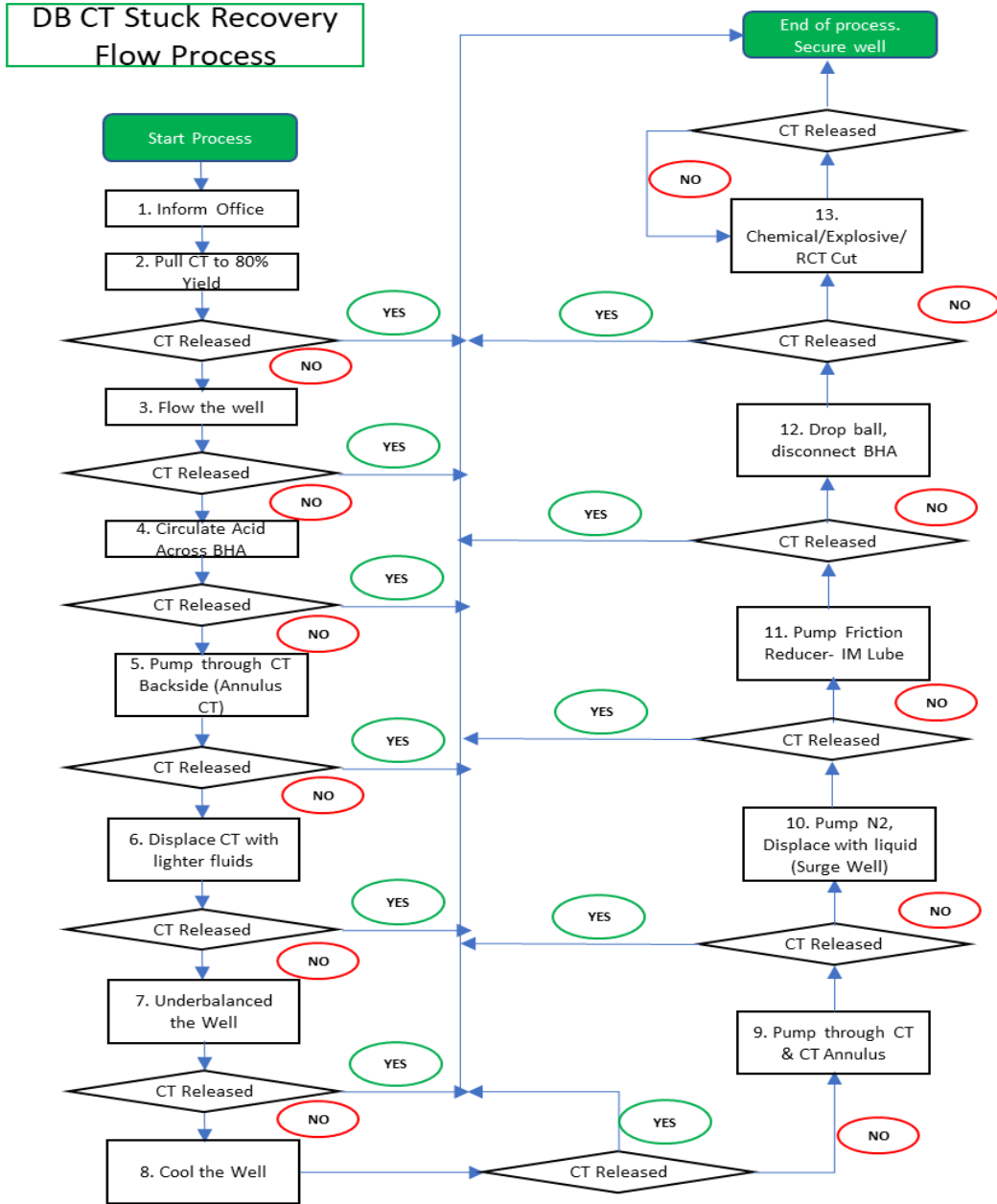

**Precautionary Steps to avoid Stuck while Cleanout in Dual string Completion:**

- 1) To monitor pressure trending all the times during operation and record for any abnormalities. If there is continue pressure increasing trend during cleanout, proceed to pick up coil to the previous pull test depth and perform flow rate test.
- 2) In the event of coil entangle on the Long string, proceed to pick up coil and simulate pumping lost prime scenario to create vibration and tip of coil wobble to release from entanglement.

**APPENDIX V – DECISION TREE (Run#1 SCO)**

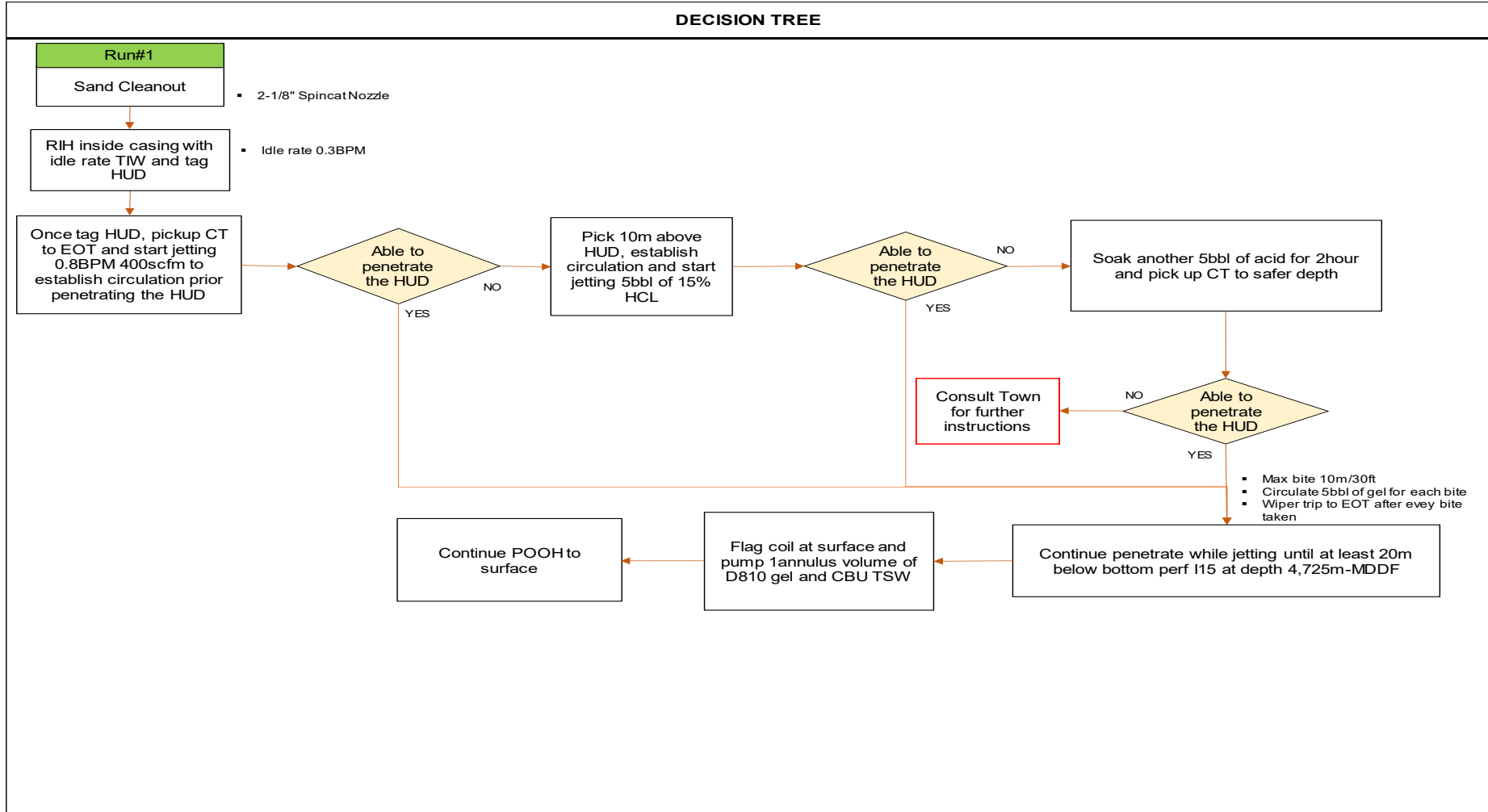

<b>DIMENSION BID</b>	DIMENSION BID COILED TUBING SERVICES		 <b>PETRONAS</b>
	ANGSI A-25	SAND CLEANOUT & RE- PERFORATION	

**DECISION TREE (Run#2 GRCCL)**

Prepared By: Muhd Shahfariz	Reviewed By: Kung Yee Han	Date: 20/6/2023	Rev. Rev.0	Controlled Document DB-CT-MSF-23011	Pg. 60
--------------------------------	------------------------------	--------------------	---------------	----------------------------------------	-----------

<b>DIMENSION BID</b>	DIMENSION BID COILED TUBING SERVICES		 <b>PETRONAS</b>
	ANGSI A-25	SAND CLEANOUT & RE- PERFORATION	

**DECISION TREE (Run#3,4 Re-per 10meter Gun)**

Prepared By: Muhd Shahfariz	Reviewed By: Kung Yee Han	Date: 20/6/2023	Rev. Rev.0	Controlled Document DB-CT-MSF-23011	Pg. 61
--------------------------------	------------------------------	--------------------	---------------	----------------------------------------	-----------

**DECISION TREE (Contingency Unloading)**

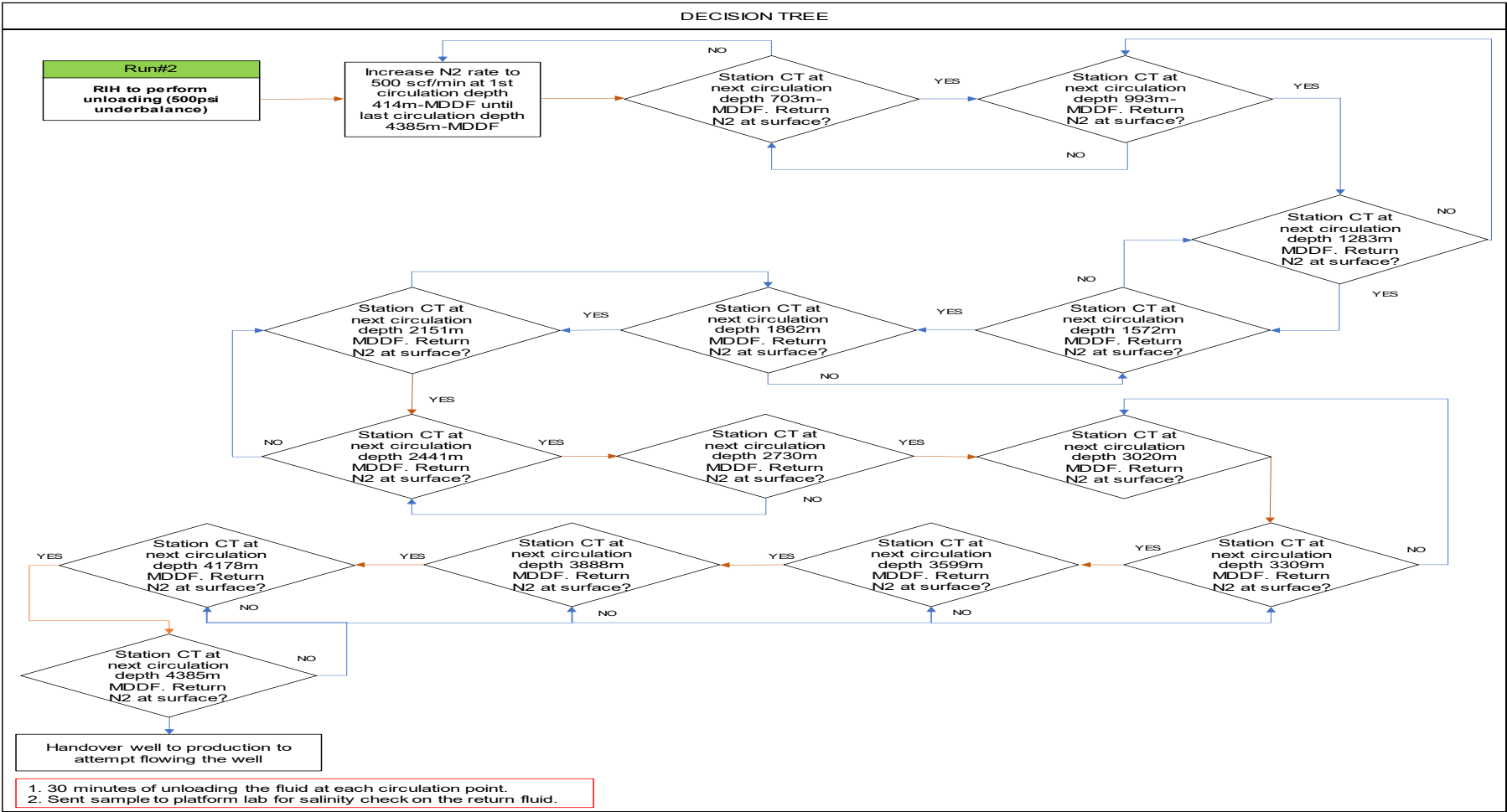

<b>DIMENSION BID</b>	DIMENSION BID COILED TUBING SERVICES		 <b>PETRONAS</b>
	ANGSI A-25	SAND CLEANOUT & RE- PERFORATION	

Prepared By: Muhd Shahfariz	Reviewed By: Kung Yee Han	Date: 20/6/2023	Rev. Rev.0	Controlled Document DB-CT-MSF-23011	Pg. 63
--------------------------------	------------------------------	--------------------	---------------	----------------------------------------	-----------