



Tool Code: PRC002

Document: MN-PRC002-H

3-Arm Production Roller Centraliser

# PRODUCTION ROLLER CENTRALISER

1<sup>11</sup>/<sub>16</sub>" , 3 Arm, GO Ends

**Operational & Maintenance Manual**

Date: 30th July 1992  
Author: Robert Holding  
Revised: 26th July 2006, Ferry van der Vorst  
Approved: Neil Harris

Tel. +44(0)1252 862 200 <http://www.sondex.com>  
Fax. +44(0)1252 862 349 email: [support@sondex.com](mailto:support@sondex.com)

This document contains proprietary information. Copyright © 2006 Sondex. All rights reserved.  
Created July 26, 2006

**Contents**

<b>0</b>	<b>About This Manual. . . . .</b>	<b>0-1</b>
0.1	Manual History	0-1
0.2	Updates To Be Used With This Manual	0-1
0.3	Technical Help	0-1
0.4	Feedback	0-1
<b>1</b>	<b>Description. . . . .</b>	<b>1-1</b>
1.1	Purpose	1-1
1.2	Application	1-1
1.3	Interfacing & Tool Combinations	1-1
1.4	Specification	1-2
<b>2</b>	<b>Safety . . . . .</b>	<b>2-1</b>
<b>3</b>	<b>Operating Procedure . . . . .</b>	<b>3-1</b>
3.1	Pre-logging Checks	3-1
3.1.1	Mechanical	3-1
3.1.2	Electrical	3-1
3.2	Connecting To Toolstring	3-2
3.3	Logging	3-2
3.4	Post-logging Disassembly	3-3
3.5	Transport, Handling & Storage	3-3
<b>4</b>	<b>Mechanical Description . . . . .</b>	<b>4-1</b>
4.1	Disassembly	4-1
4.1.1	Upper Sub & Lower Sub	4-1
4.1.2	Lower Connector	4-1
4.1.3	Upper Connector	4-2
4.1.4	Spring Force	4-2
4.1.5	Centraliser Arms	4-2
4.1.6	Springs & Housings	4-3
4.2	Reassembly	4-4
4.2.1	Springs & Housings	4-4
4.2.2	Centraliser Arms	4-4
4.2.3	Spring Force	4-5
4.2.4	Upper & Lower Connectors	4-6
	<i>Top Connector</i>	4-6
	<i>Bottom Connector</i>	4-6
4.2.5	Upper Sub & Lower Sub	4-6
4.2.6	Final Assembly Stages - Grease Filling	4-7

---

<b>5</b>	<b>Extended Checks</b> .....	<b>5-1</b>
5.1	Preventative Maintenance	5-1
5.1.1	Grease & Lubricants	5-1
5.1.2	Mechanical	5-1
5.1.3	Electrical	5-2
5.2	Extraordinary Maintenance	5-2
5.2.1	Corrosion & Wear	5-2
5.2.2	O-ring Replacement	5-2
5.2.3	Contact with H <sub>2</sub> S	5-3
5.2.4	Roller Replacement	5-3
5.2.5	Spring Replacement	5-3
<b>APPENDIX A</b>	<b>Equipment &amp; Recommended Spares</b> .....	<b>A-1</b>
A.1	Ancillary Equipment	A-1
A.2	Maintenance Equipment	A-1
A.3	Recommended Spares	A-1
<b>APPENDIX B</b>	<b>Drawings &amp; Parts Lists</b> .....	<b>B-1</b>
B.1	Mechanical Drawings	B-1

## 0 ABOUT THIS MANUAL

### 0.1 MANUAL HISTORY

Date	Issue	Description	Auth	Chk	App
31/01/01	F	Manual updated to use new templates.	DMO		
27/11/01	G	Splashproof seals added to 1 <sup>11</sup> / <sub>16</sub> " tools (see ECR 940)	DMO		PD
26/07/06	H	Template, Logging and Maintenance Updates. Also: ECR 1157, 1354 & 2174, 1076.	FV	SA	NH

### 0.2 UPDATES TO BE USED WITH THIS MANUAL

Consult the CD Directory for the appropriate Manual Updates to be used with this Manual.

### 0.3 TECHNICAL HELP

For further technical help contact Sondex as follows:

Address: Unit 1, Saxony Way,  
Blackbushe Business Park,  
Yateley, Hampshire,  
GU46 6AB  
United Kingdom

Telephone: +44(0)1252 862 200  
Fax: +44(0)1252 862 349  
Email: [support@sondex.com](mailto:support@sondex.com)

### 0.4 FEEDBACK

Please help us improve future issues of this manual by sending your comments or corrections to [Documentation-UK@sondex.com](mailto:Documentation-UK@sondex.com), referencing the document number.

Thank you.

**Photographs and sketches are for illustration purposes only. Depending on the tool model that you have, certain features or dimensions may differ from those shown.**

## 1 DESCRIPTION

This compact, 3 arm, inline, low friction roller centraliser is designed to centre production logging tools accurately in vertical or deviated wells.

Recent tools have widened arms to minimise the risk of the tool sticking in casing/tubing splits and to help when re-entering the tubing. The 3 sets of stainless steel arms are mechanically linked to ensure accurate centering, providing a constant radial force through the full operating diameter. The tool closes to  $1\frac{11}{16}$ "", but alternative rollers can be provided for larger closing diameters.

For safety both the upper and lower collars are free to slide on the centre rod.

Inside the central rod is a single feed through shaft. The electrical feedthrough enables the tool to be used at any point in the string. The monoconductor is passed from upper to lower connectors.

The corrosion resistant alloys used are suitable for normal or H<sub>2</sub>S use, except for the Springs, which will need to be exchanged for a NACE compliant material before use in H<sub>2</sub>S.

### 1.1 PURPOSE

Most Production Logging Tools give the best performance when they are centred in the borehole. Some tools, such as Gamma Ray and Temperature, are relatively insensitive to borehole position. The CCL for example, gives a larger response when it is not centred.

The Sondex Knuckle Joint (PKJ series) can be used to isolate sections of the toolstring that must be centred from sections that are to be positioned against the casing or tubing wall, including any weights. Centred tools are less likely to suffer from wear and toolstring drag. Downhole video cameras must be centred normally to give evenly lighted pictures.

### 1.2 APPLICATION

- Centralisation of logging tools in vertical, deviated or horizontal wells.
- Centralisation of slickline tools.
- Minimisation of toolstring drag and wear.
- Can be used as a tubing end locator by observing line tension when pulling into the tubing.

### 1.3 INTERFACING & TOOL COMBINATIONS

- Simultaneous Operation with other PL Tools.
- $1\frac{3}{16}$ " UN 12 tpi Sondex, GO or other Heads.



Figure 1.1 PRC

**1.4 SPECIFICATION**

Parameter	Specification	Remarks
Temperature Rating	350°F (177°C)	
Pressure Rating	15000psi (103.4MPa)	
Diameter (min)	1 <sup>11</sup> / <sub>16</sub> " (43mm) <sup>a</sup>	
Diameter (max)	9" (229mm) <sup>a</sup>	
Make-Up Length	22.97" (583mm)	
Overall Length	26.77" (680mm)	Including Thread Protectors.
Weight	7lb (3.2kg)	
Centralising Force	20lb (9.1kg) <sup>b</sup>	40lbs (18.14kg) Optional.
End threads (top/bottom)	GO type A 1 <sup>3</sup> / <sub>16</sub> " 12 UN (female/male)	
End connectors (top/bottom)	4mm single conductor (male pin/female socket)	
Materials	H <sub>2</sub> S resistant, hard stainless steel rollers (carbide coating on standard rollers only), dry bearings.	

<sup>a</sup>. Closing & Opening diameter can be changed with different rollers. Other rollers optional, see [Section 5.2.4](#).

<sup>b</sup>. Centralising force can be changed with different springs. Other springs optional, see [Section 5.2.5](#).

## 2 SAFETY



### **Warning!**

#### **SPRING FORCE!**

Take care when removing the Closing Ring. The Centraliser has strong springs, which will cause the arm to open with great force.

Care must be taken dismantling the spring housing as there is considerable force acting on the endcap when it is being removed.



### **Warning!**

**HOT WORK!** Sondex equipment may, under certain circumstances or failure modes, become a potential source of ignition. Using it must therefore be considered "**HOT WORK**" and appropriate precautionary procedures should be followed when testing at surface in areas where there is a risk of gas leaks or other potentially explosive atmospheres.



### **High Temperature Grease**

A High Temperature Grease (Castrol Spheerol L-EP2 or Castrol LMX) is used to fill the Centraliser Body of the tool during maintenance. Contact with skin or eyes can be harmful.

For more details see the [Material Safety Data Sheet for Castrol Spheerol L-EP2](#) or [Material Safety Data Sheet for Castrol LMX](#) respectively.



### **Liquid O-ring**

LOR101 is used for lubricating the tool during maintenance. Contact with skin or eyes can be harmful. For more details see the [Material Safety Data Sheet for Liquid O-ring](#).

### 3 OPERATING PROCEDURE

**Warning!****SPRING FORCE!**

Take care when removing the Closing Ring. The Centraliser has strong Springs, which will cause the Arm to open with great force.

#### 3.1 PRE-LOGGING CHECKS

##### 3.1.1 MECHANICAL

Ref.: PRC002 General Assembly *02009*

- 1 Clean and grease lower O-ring seals. Replace O-rings (item 32) if damaged.

**Note:** Viton® O-rings are normally used, but the material choice depends on downhole conditions.

- 2 Check for excessive wear of Arms. Replace if necessary.
- 3 Check that wear on Rollers and Axles is acceptable. Check that all 3 Rollers (item 13) are free to rotate. If any do not run freely, they should be disassembled and serviced, see [Section 4.1.5 Centraliser Arms](#).
- 4 Check the spring action. Note that the spring force can be altered.
- 5 Check that all six Grub Screws (item 21) are tight. These hold the Ball Bearings (item 20) in place, which prevent the Upper and Lower Subs (items 3 & 4) from rotating on the main Shaft (item 1).
- 6 Check that the 2 Centraliser Bodies (item 5) are filled with high melting point grease (e.g. Castrol LMX), see [Section 5 Extended Checks](#).

**Note:** Grease is normally applied with the Centraliser Arms closed and the Closing Ring fitted.

- i. Remove the grease port Grub Screw (item 19) & fill the End Cap assembly with grease.
- ii. Replace the Grub Screw (item 19).

**Note:** If the Centraliser Arms are opened after Grease filling, grease will be forced out of the Spring Collar location slots and Arm Location positions.

- iii. Complete for both spring assemblies.

- 7 Ensure that upper and lower Electrical Connectors are clean, dry and undamaged.

##### 3.1.2 ELECTRICAL

- 1 Using a Multimeter, measure the upper to lower pin resistance. The reading should be less than 0.5Ω.
- 2 Using a Megohm Meter, set to 500V, measure the pin to housing resistance. The reading should be greater than 5MΩ.

### 3.2 CONNECTING TO TOOLSTRING

Upper and lower tool joint O-rings and seal surfaces should be clean, undamaged and lightly greased. The PRC may be inserted into a Production Logging toolstring (wireline or memory) in any location or used with Coiled Tubing.

**Note:** The main tool joints are only pressure tight when connected to another pressure tight tool. If well fluid enters these joints, the PRC and the rest of the toolstring may be flooded.

3 centralisers will hold a typical Sondex toolstring straight and ensure accurate centering in deviations up to 70°. If extra weights are included, they should be isolated from the centred string with a Sondex Knuckle Joint (PKJ series).

Knuckle Joints (PKJ) can be used within a toolstring to separate tools that need to be centralised, from tools that need to be positioned against the casing or tubing.

### 3.3 LOGGING

The following are guidelines only and must be used in conjunction with local policy and specific well site conditions both downhole and at surface. The table below is appropriate for near vertical wells and must be adjusted accordingly when in deviated wells. Use of a Head Tension Unit is highly recommended.

**Note:** Do not exceed the calculated safe working load of your selected weakpoint. If in doubt, use a head tension unit, especially in deviated wells where calculation from surface tension is less accurate.

Depth (ft)	Speed Pulling Out of Hole	Speed Running in Hole
In/out of catcher (pressure rig up only)	Dead slow or manual.	
30 to 150	30ft/min	
150 to 400	60ft/min	
>400 clear cased hole	Surface tension not to exceed 120% of tension when tool stationary. Speed not to exceed 150ft/min.	Surface tension should not be less than 80% of tension when tool stationary. Speed not to exceed 150ft/min.
>400 clear open hole	Surface tension not to exceed 130% of tension when tool stationary. Speed not to exceed 150ft/min.	Surface tension should not be less than 70% of tension when tool stationary. Speed not to exceed 150ft/min.
Approaching potential obstacles <sup>a</sup>	30ft/min	
Logging Data	Do not exceed the above speeds.	

<sup>a</sup>. For example: Reduced diameters, gas lift mandrels, fluid levels, valves, tubing shoes, packers, cross overs and other downhole equipment.

**Note:** Although the mechanical arrangement allows very large centering forces to be achieved, large closing forces may result in undesirably high wireline tension as the toolstring enters a small tubing from a large casing. If possible use more centralisers rather than stronger centralisers.

### **3.4 POST-LOGGING DISASSEMBLY**

The tool should be cleaned before the toolstring is disassembled.

Ensure that well fluid does not reach the Electrical Connectors. Refit Thread Protectors and Closing Ring (item 18, not shown on drawing).

**Before storage:**

- 1 Check that Rollers rotate. Spray them with WD-40<sup>®</sup> after every run.
- 2 Re-grease body spring assemblies, see [Section 5.2 Extraordinary Maintenance](#).

Always keep the tool in its transport case before and after logging.

### **3.5 TRANSPORT, HANDLING & STORAGE**

Store with end thread lightly greased and water tight Thread Protectors fitted.

Do not store in the fully closed configuration for excessively long periods of time as the Springs may suffer from compression set.

**Note:** Continued storage of the centraliser with its Arms closed and its Retaining Collar fitted may lead to spring set and loss of performance. If the Centraliser is to be stored for any long period of time, it is recommended that the Centraliser is stored with its Arms open.

Transport the tool with Thread Protectors and Closing Ring fitted.

Do not subject tool to extreme shock, such as dropping or hitting with a hard object.

Do not store the tool, whilst still dirty from logging, or wet from cleaning as this may lead to the initiation of corrosion.

## 4 MECHANICAL DESCRIPTION



### Warning!

#### SPRING FORCE!

Care must be taken dismantling the tool as there is considerable force acting on the End Cap of the Spring Housing when disassembled.

Ref.: PRC002 General Assembly

02009

### 4.1 DISASSEMBLY

#### 4.1.1 UPPER SUB & LOWER SUB

**Note:** It is not essential to release the spring pressure prior to removing the Subs, but it is recommended, see [Section 4.1.4](#).

**Note:** The Subs are matched to the Shaft. Before removing, mark each Sub and the Shaft so that they can be re-fitted in their correct positions.

- 1 Remove Grub Screws (6x item 21) from Lower Sub (item 3) and Upper Sub (item 4).
- 2 Slightly rotate the Lower and Upper Sub (items 3 & 4) with respect to the Shaft (item 1).

**Note:** This releases the Ball Bearings (item 20), which normally prevent rotation of the Subs on the Shaft.

- 3 Unscrew both the Upper Sub (item 4) and Lower Sub (item 3) from the Shaft (item 1).

**Note:** The pair of O-rings (item 29) at each end of the Shaft prevent fluids passing beyond the thread of the Shaft. **The O-rings maintain integrity between the Shaft and the Sub, and care should be taken not to damage them. Replace if damaged.**

#### 4.1.2 LOWER CONNECTOR

**Note:** This procedure is easier if the Lower Sub (item 3) has been removed first. Refer to [Section 4.1.1](#).

**Note:** It is not essential to release the spring pressure prior to removing the Lower Connector, but it is recommended, see [Section 4.1.4](#).

- 1 Remove the Banana Pin (item 35) from the end of the Connecting Rod (item 2).
- 2 Remove the Half Nut (item 34).
- 3 The Seal Retainer (item 37), Seal (item 39), Peek Insulator (item 15), Lower GO Insulator (item 16) and Seal (item 40) may now be removed as a group.

**Note:** A twisting action will help to traverse the Seal over the threads of the Connecting Rod (item 2). Alternatively, remove the Seal Retainer (item 37) first, hook out the Seal (item 39), followed by the Insulator (item 15), Lower GO Insulator (item 16) and Seal (item 40).

The remaining upper Upper Connector Assembly and Connecting Rod may now be removed by withdrawing them from the upper end of the tool, refer to [Section 4.1.3](#).

## 4.1.3 UPPER CONNECTOR

**Note:** It is not essential to release the spring pressure prior to removing the Upper Connector, but it is recommended, see [Section 4.1.4](#).

- 1 Withdraw the Upper Connector Assembly and Connecting Rod (item 2) from the upper end of the tool.
- 2 Slide the Insulator (item 31) from the Connecting Rod (item 2).
- 3 The Seal (item 39), Insulator (item 14) and Seal (item 38) may now be removed as a group and can be taken apart if required.

**Note:** A twisting action will help to traverse the Seal (item 39) over the threads.

## 4.1.4 SPRING FORCE



**Warning! SPRING FORCE!** Care must be taken dismantling the spring housing as there is considerable force acting on the End Cap when it is being removed.

**Note:** When removing the Spring force, it is safer to leave the Centraliser Bodies and Subs positioned on the Shaft. This to ensure the Springs remain on the Shaft at all times and cannot cause serious damage or danger when accidentally exiting the Centraliser Bodies.



**Warning! SPRING FORCE!** Take care of fingers when Springs accidentally exit the Spring Bodies.

Note that there is a spring assembly on either side of the tool.

- 1 Hold the Centraliser Body (item 5) in a soft-jawed vice and using a C-spanner or tommy bar, slowly unscrew its End Cap (item 8).

**Note:** Care should be taken at this stage due to the large spring force acting on the End Cap.

Repeat this process for the other Centraliser Body and End Cap. This ensures that the stored spring force has been dissipated, making the tool safe to work on.

## 4.1.5 CENTRALISER ARMS

- 1 If not already done, release the spring pressure as described in [Section 4.1.4](#).
- 2 Remove the Screw (item 27), clamping the Upper Arm (item 7) and the Lower Arm (item 6). The Spacer (item 11) will now be free, remove and retain the Spacer for re-use later.
- 3 Insert the Screw (item 27) into the Upper Arm (item 7), but from the other side from which the Screw (item 27) was extracted.
- 4 Place a small piece of metal into the slot of the Upper Arm (item 7), so when the Screw (item 27) is tightened, it presses against the metal and forces the two sides of the Arm apart.

- 5 Continue to part the two sides until there is enough space to allow the removal of the Roller Assembly (item 12, 13 & 28), then remove the Screw (item 27) and the small piece of metal, releasing the stress in the splayed Arm.
- 6 Remove Spirol Pins (6x item 25). Note the position of the Arms (item 6 & 7) in the Centraliser Body (item 5), since they should be refitted in the same locations.

**Note:** The Spirol Pins do not have to be removed completely, unless replacement (due to poor fit or damage) is required.

### 4.1.6 SPRINGS & HOUSINGS



**Warning!** **SPRING FORCE!** Care must be taken dismantling the Spring Housing as there is considerable force acting on the End Cap when it is being removed.

Note that there is a spring assembly on either side of the tool.

- 1 If not already done, release the spring pressure as described in [Section 4.1.4](#).
- 2 Remove End Cap (item 8) from Shaft.
- 3 Each Spring (item 24) or Springs (items 22 & 23) can now be removed.
- 4 Each Spring Housing (item 5) has a Spring Collar (item 9) located inside, at its conical end. This can be removed from the Body by a slight tilting action. Make a note of which Spring Housing each Spring Collar was removed from.

**Note:** The Collar becomes pitted where the Tungsten Pins on the ends of the Arms impinge upon the Collar. This is normal and is a design feature, as this 'bedding-in' maintains equal force on all three Arms. Therefore, replace the Spring Collar into the same Spring Housing that it was removed from. This should then match up with the correct Arms, which should have already been positionally marked before removal. Refer to [Section 4.1.5](#) operation 6.

## 4.2 REASSEMBLY

**Note:** Ensure that parts are clean and undamaged before reassembly.

### 4.2.1 SPRINGS & HOUSINGS

**Note:** If the Spring Collars (item 9) are re-used, their position is relevant to the Centraliser Arms (items 6 & 7), removed previously, as the Arms have been through a 'bedding-in' process with their respective Spring Collars (item 9) during previous use. See also [Section 4.1.5](#) operation 6 and the last note in [Section 4.1.6](#).

If new Arms and Spring Collars are fitted, the orientation of the Spring Collars does not matter.

- 1 Refit the Spring Collar (item 9) into the Spring Housing, ensuring that the protruding Pin (item 10) is located in the small slot in the Spring Housing.

**Note:** If the Centraliser Arms are replaced in [Section 4.2.2](#), the Spring Collars need to be replaced as well.

**Note:** To do this, slide the Spring Collar in at an inclined angle until it is possible to rotate the Pin into the slot.

- 2 Slide the Spring Housing (item 5) and its assembled Spring Collar (item 9) over the Shaft.
- 3 Fit the Spring (item 24) into the Spring Housing (item 5).
- 4 Locate the End Cap (item 8) over the Shaft (item 1).
- 5 Temporarily screw on the respective End Sub.
- 6 Screw in the End Cap (item 8) just a few turns into the Spring Housing (item 5). Ensure the Spring is not excessively compressed.



**Warning!** There will be some spring load acting on the parts within the Spring Housing assembly.

**Note:** A Spacer Collar can be used to compress the Spring. If a Collar is not available, vertical palm pressure against a flat, solid surface can be used. Maintain pressure and engage the thread on the Cap with the thread in the Centraliser Body.

- 7 Repeat the operations 1 to 6 for the other end of the tool.

### 4.2.2 CENTRALISER ARMS

**Note:** Take any previously fitted parts and any annotations applied to them into account, to ensure correct location for refitment. At this stage, the relationship between the Centraliser Arms, the Spring Housing and Spring Collar becomes especially important. The relationship with the End Subs will be ensured at a later stage.

**Note:** The Upper Arms (item 7) are weaker than the Lower Arms (item 6). The Upper Arms (item 7) are therefore fitted towards the top of the tool during assembly.

- 1 Inspect Arms for wear and replace if necessary.

**Note:** If the Centraliser Arms are replaced, the Spring Collars need to be replaced as well. When new Pins are fitted, the carbide Pins should contact the Spring Collar simultaneously and will move freely on the Shaft. The Pins should be located square to the design clearances. The Pins will find their own depth into the Collar.

- 2 Refit the Arms (items 6 & 7) into their original positions on the Centraliser Body (item 5) and secure with Spirol Pins (item 25).



**Caution!** DO NOT compress the Centraliser Arms until **all** Arms are located in their respective positions. Dummy Pins can be used to assist assembly.

**Note:** Fit new Spirol Pins (item 25) to the Arm Assembly if damaged, or if the Arms were difficult to rotate or particularly loose.

**Note:** If new Centraliser Arms are fitted then, once three Arms have been located onto one Spring Housing, move them about over their full range. There will be some spring resistance, but it should not be excessive as the End Caps were not screwed in fully in [Section 4.2.1](#).

If there are any issues with physical clashes between parts, then investigate further. New Arms may need to be fitted in some areas. This can be done by dressing as required with suitable files.

- 3 Insert the Screw (item 27) into the Upper Arm (item 7) on the opposite side of the fitting location of Screw (item 27).
- 4 Place a small piece of metal into the slot of the Upper Arm (item 7), so when the Screw (item 27) is tightened, it presses against the metal and forces the two sides of the Arm apart.
- 5 Continue to part the two sides until there is enough space to allow fitting of the Roller Assembly (item 12, 13 & 28).

**Note:** Fit new Bushes (item 28) to the Arm Assembly if damaged, or if the Arms were difficult to rotate or particularly loose.

- 6 Remove Screw (item 27) and the small piece of metal. Fit Spacer (item 11), line the Spacer (item 11) up with the screw holes in the Arms and secure the Upper Arm (item 7) and the Lower Arm (item 6) with the Screw (item 27).

### 4.2.3 SPRING FORCE

**Note:** Having refitted all Arms and reconnected all Arms to each other, it is now possible to reinstate the full spring pressure.

- 1 Fully screw each End Cap (item 8) into its respective Spring Housing (item 5).



**Warning!** **SPRING FORCE!** The centralising section of the tool will now be primed with variable spring force for the remainder of the tool reassembly. Ensure the Arms are left fully open, which will ensure that minimal spring force is present within the centraliser section.

**4.2.4 UPPER & LOWER CONNECTORS**

Remove the End Subs, temporarily fitted in [Section 4.2.1](#), remembering which Sub relates to which end of the Shaft and fitted Arms.

**4.2.4.1 Top Connector**

- 1 Replace a Seal (item 38) onto the Insulator (item 14).
- 2 Replace the Seal (item 39) onto the Connecting Rod (item 2), ensuring the Seal is greased and undamaged. Take care not to damage the Seal when fitting it over the thread.
- 3 Slide the Insulator assembly fully onto the Connecting Rod (item 2). Note the orientation of the Insulator (item 14) on the assembly drawing.
- 4 Slide the PTFE Insulator (item 31) from the other end onto the Connecting Rod (item 2).
- 5 Refit the entire assembly through the Upper End of the main Shaft (item 1).

**4.2.4.2 Bottom Connector**

- 1 Replace the Seal (item 40) and fit it into the Lower GO Insulator (item 16).
- 2 Refit the Insulator (item 15), Lower GO Insulator (item 16), a replacement Seal (item 39) and Retainer (item 37) onto the Connecting Rod (item 2). Take care not to damage the Seal when fitting it over the thread.
- 3 Refit the Half Nut (item 34).

**Note:** The Half Nut (item 34) can be used to pull the Insulator (item 15), Lower Insulator (item 16), the Seal (item 39) and Retainer (item 37) together. This action will also secure the 2 Insulators (item 14 & 15) against the Shaft (item 1), creating a clamping action.

- 4 Refit the Banana Pin (item 35) onto the Connecting Rod (item 2) and tighten against the Half Nut (item 34).

If the Upper and Lower Subs were not fitted previously, they can be fitted now as described in [Section 4.2.5](#).

**4.2.5 UPPER SUB & LOWER SUB**

**Note:** Although the Shaft (item 1) is symmetrical, it is recommended that the Subs are refitted in their original positions, so that the Ball Bearings (items 20) can engage with the original indentations.

- 1 Replace the O-rings (4x item 29), ensuring the grooves and O-rings are clean, greased and undamaged.
- 2 Refit the Lower Sub (item 3) and Upper Sub (item 4).
- 3 Replace the Ball Bearings (6x item 20) and secure the Lower Sub (item 3) and Upper Sub (item 4) with the Grub Screws (6x item 21).

## 4.2.6 FINAL ASSEMBLY STAGES - GREASE FILLING

**Note:** Grease is normally applied with the Centraliser Arms closed and the Closing Ring fitted.

- 1 Remove the grease port Grub Screw (item 19) & fill the End Cap assembly with grease.
- 2 Replace the Grub Screw (item 19).

**Note:** If the Centraliser Arms are opened after Grease filling, grease will be forced out of the Spring Collar location slots and Arm Location positions.

## 5 EXTENDED CHECKS

See also: [APPENDIX B Drawings & Parts Lists](#)

### 5.1 PREVENTATIVE MAINTENANCE

#### 5.1.1 GREASE & LUBRICANTS

Sondex recommends the use of "Liquid O-ring type 101" (p/n LOR101) on threads and O-rings, see [APPENDIX A](#).

All O-rings and housing threads are assumed to be and must be lightly greased unless specifically indicated differently.

Correct use of grease and lubricants is essential to the maintenance of all Sondex downhole equipment.

Note that some threads are internal such that grease can get inside the tool. Do not use excessive quantities.

Sondex does not recommend Copper loaded greases since some types can cause electrical leaks. Some types are also not suitable for use on O-rings. Silicone grease may be used on O-rings, but must be kept clear of threads especially stainless to stainless.

Cavities, e.g. spring housings, should be filled with a suitable heavy high melting point grease, such as Castrol Spherol L-EP2 or LMX.



**Warning!** The use of certain greases, such as some types of Lubriplate, can cause electrical failure if they have any volatile content, which can burn off producing corrosive gasses inside the tool.

#### 5.1.2 MECHANICAL

Ref.: PRC002 General Assembly [02009](#)

- 1 Remove dirt and old grease from Pressure Housing threads and O-rings and replace with fresh.
- 2 Inspect O-rings for damage or ageing/hardening and replace where required.
- 3 Check for:
  - Damaged components.
  - Loose screws/nuts/components/connectors.

**Note:** If RTV or similar compound is used to secure loose components, it must be fully cured before housing is replaced.

- Heat or chemical damage (discoloured components).
  - Incorrect thread grease or excessive quantity, see [Section 5.1.1](#).
  - cleanliness of connectors and loose/bent pins before replacing.
- 4 Check all fixings for tightness.

- 5 Check Grub Screws (6x item 21 & 2x item 19) are tight.
- 6 Ensure that upper and lower electrical connectors are clean, dry and undamaged.

### 5.1.3 ELECTRICAL

- 1 Using a Multimeter, measure the upper to lower pin resistance. The reading should be less than  $0.5\Omega$ .
- 2 Using a Megohm Meter, set to 500V, measure the pin to housing resistance. The reading should be greater than  $5M\Omega$ .

## 5.2 EXTRAORDINARY MAINTENANCE

Ref.: PRC002 General Assembly 02009

### 5.2.1 CORROSION & WEAR

The main mechanical parts of the Centraliser are made from corrosion resistant materials. However, the standard springs are not fully corrosion resistant. Frequent greasing of the spring assemblies, as described below, not only reduces the potential for any corrosion to the springs, but also lubricates the action of the Centraliser.

It is therefore recommended that the Centralisers are disassembled for inspection only about once a year, unless the well fluids are particularly corrosive, in which case inspection should be more frequent.

- 1 The Screws holding the Arms onto the Spring Bodies should be checked for tightness before and after every job.
- 2 The Roller Bushes should be checked for wear between jobs and replaced if necessary.
- 3 The Rollers should be replaced if they have worn excessively.

### 5.2.2 O-RING REPLACEMENT

The following O-rings need replacement after every run.

- 2x item 32.

The following O-rings need replacement after 5 runs or every 3 months.

**Note:** All O-rings can be replaced without disassembly of the Spring Section.

- 4x item 29.
- 2x item 39.
- 1x item 40.
- 1x item 38.

It is advised to replace all O-rings when the tool is disassembled for inspection.

### 5.2.3 CONTACT WITH H<sub>2</sub>S

In the case of high H<sub>2</sub>S, the springs may need replacing after only a few days after initial H<sub>2</sub>S contact. In this case, inspection of the springs after every job is essential.

To determine contact with H<sub>2</sub>S, check for discoloration of the Upper Sub (item 4) and Lower Sub (item 3). These parts are made of Al/Bronze and will turn black when in contact with H<sub>2</sub>S. Local well site knowledge will also contribute to determine the possibility of H<sub>2</sub>S exposure.

Also replace the following O-rings:

- 4x item 29.
- 2x item 32.
- 2x item 39.
- 1x item 40.
- 1x item 38.

### 5.2.4 ROLLER REPLACEMENT

**Note:** There is an option to fit an optional Roller, instead of the standard Roller (item 13), which changes the tool OD.

Parameter	Tool OD (Standard)	Tool OD (Optional)
Closing Diameter	1 <sup>11</sup> / <sub>16</sub> "	2 <sup>1</sup> / <sub>8</sub> "
Roller diameter	1 <sup>1</sup> / <sub>2</sub> "	3 <sup>3</sup> / <sub>4</sub> "

Both roller options are available with carbide coating.

If the Pin (item 12) does not show any wear it may be re-used. The Bush (item 28) does wear and should be replaced together with the Roller. Rollers are usually supplied with the Bush fitted.

### 5.2.5 SPRING REPLACEMENT

**Note:** Alternative Springs may be fitted to achieve a different centralising force.

Parameter	Standard Tool	Optional
Centralising Force	25lbs	40lbs
Item Number	item 22 & 23 (combined)	item 24

**APPENDIX A EQUIPMENT & RECOMMENDED SPARES**

Item	Part No	Description	Qty	Remarks
1	PRC002	Production Roller Centraliser, 1 <sup>11</sup> / <sub>16</sub> " , GO	1	

**A.1 ANCILLARY EQUIPMENT**

Item	Part No	Description	Qty	Remarks
1	17025	Closing Ring	1	

**A.2 MAINTENANCE EQUIPMENT**

Item	Part No	Description	Qty	Remarks
1	91050	Tool Kit for all 1 <sup>11</sup> / <sub>16</sub> " Tools SX and GO	1	
2	LOR101	Grease for O-rings & threads	1	5oz. pot
3	LOR101L	Grease for O-rings & threads	AR	12oz. pot

**A.3 RECOMMENDED SPARES**

Item	Part No	Description	Qty	Remarks
1	KITB-PRC002	Basic Spares Kit	1	To support 1 run in hole.
2	KITR-PRC002	Recommended Spares Kit	1	To support 25 runs in hole.

All spares kits, mentioned in this section, can be supplied upon request. Contact Sondex and quote the part number of the spares kit for additional information or when ordering the spares kit.

As a guidance:

- A Basic Spares Kit mainly contains essential maintenance equipment, O-rings and parts, which are likely to need replacing on a run-by-run basis (including spare parts for the initial tool run) or parts that can be lost easily (like grub screws).
- A Recommended Spares Kit has got a multitude of the same parts as a Basic Spares Kit, supplemented by parts that might need replacement at a lower frequency, i.e. 5 runs and/or 25 runs.

Note that the information above is a guidance only and Sondex reserves the right to change the contents of the Spares Kits as required.

**Note:** Spares kits suitable for remote logging operation can be supplied upon request.

PARTS LISTING					
Part:  <b>91050</b>	Issue:  -		Drawn: NGH	Checked: PD	Approved: DJF
			Date: 14/01/2002	Date: 14/01/2002	Date: 14/01/2002
Description: Tool Kit for all 1 11/16 Tools SX and GO					

CHANGE HISTORY					RELATED DOCUMENTS		
Iss	Date	Remarks	Chkd	Appr	# Documents	Issue	Notes
-	14/01/2002	Initial Release	PD	DJF			

PARTS LIST							
Item	Part No.	Issue	Description	Component Value	Qty	Units	Remarks
001	91005	-	Spanner Open Ended 42mmx38mm		2	ea	
002	91019	-	Spanner C 50mm 35mm		1	ea	
003	10038	A	Spanner Box 3/8 x 5/16 Modified		2	ea	
004	91028	-	Spanner 3/8x5/16		1	ea	
005	91027	-	Spanner Single Open End 18mm		1	ea	
006	91029	-	Key Hex Metric		1	ea	
007	91030	-	Punch Pin Parallel set		1	ea	
008	00615	A	Assy Spanner PKJ		1	ea	
009	91293	PT1	Screwdriver Parallel tip (3 0 x 75)		1	ea	
010	91105	-	Toolroll With SX Badge Large Black		1	ea	
011	91104	-	Screwdriver Parallel tip (5 5 x 200)		1	ea	
012	91103	-	Pliers Circlip 812 Chrome/Van		1	ea	
013	91102	-	Pliers Mini Flat Nose 5 Inch		1	ea	
014	10037	A	Bar Tommy		2	ea	
015	10051	A	Kemlon tool Sondex - 4BA Hex Socket		1	ea	
016	91280	-	Hammer, 4oz ball pein		1	ea	
017	91130	-	Pin C Spanner 35-50mm		1	ea	

(AR = As Required)

**APPENDIX B DRAWINGS & PARTS LISTS**

**B.1 MECHANICAL DRAWINGS**

<b>Description</b>	<b>Drawing</b>	<b>Parts List</b>
PRC002 General Assembly	02009-G	02009-G

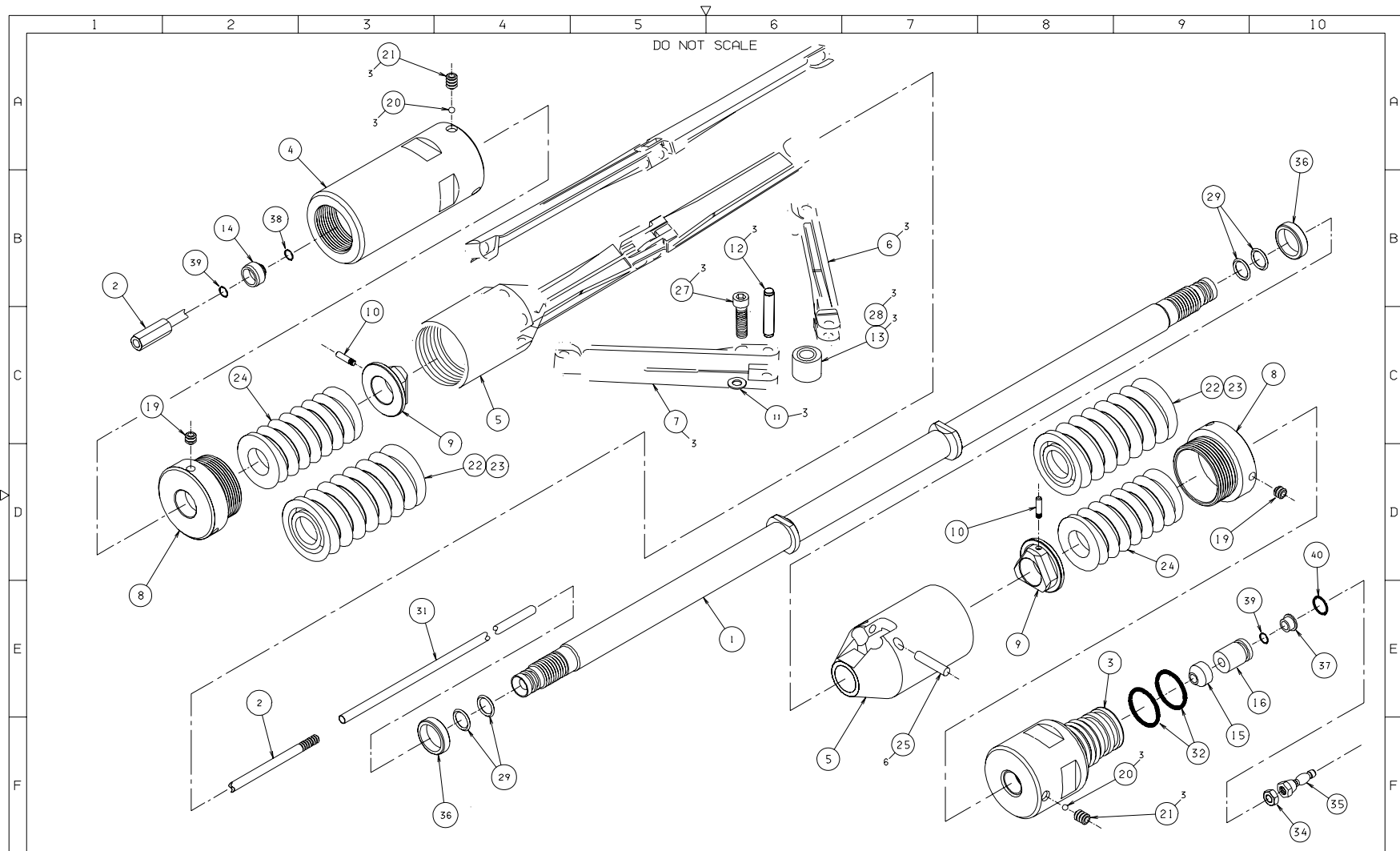

DRAWN DO	CHECKED NGH	APPROVED AJB	ISS G	DESCRIPTION ITEM 33 REMOVED - REFER ECR 1076	APPD TLS	DATE 11/03/02	<b>Sondex</b> Tel. 0118 932 6755 THIS DRAWING IS THE PROPERTY OF Sondex AND SHALL NOT BE COPIED OR USED WITHOUT PRIOR PERMISSION	MACHINE FINISH 64	USED ON PRC 02	TITLE ASSY $\varnothing$ 1-11/16" ROLLER CENTRALISER - GO
DATE 08/02/91	DATE 27/11/29	DATE 29/06/98	F	SPLASH PROOF SEALS ADDED - REFER ECR 940	TLS	20-11-01		GEN TOL 0. X $\pm$ 0.020" 0. XX $\pm$ 0.010" 0. XXX $\pm$ 0.005" ANGLE $\pm$ 0.5°	SHEET 1/1	DRAWING No. 02009
DIM IN INCHES	MATL: SEE DETAIL DRAWINGS		E	ITEMS. 2, 14 & 15 UPISSUED OR CHANGED	AJB	29-06-98	THIRD ANGLE PROJECTION			
SCALE NTS	A 2		D	REFER C/R 207. ITEMS 6&7 NOW SUB ASSYS	AJB	22-12-97				
			C	SUBS NOW HAVE 4 SPANNER FLATS. REFER C/R071(OCT95)	DJF	23-02-96				
			B	SPACERS (ITEM 16) ADDED	TJK	23-06-94				

SONDEX FM No: F0022

PARTS LISTING					
Part:	Issue:		Drawn:	Checked:	Approved:
02009	G		DO	NGH	AJB
Description:			Date:	Date:	Date:
Assy 1 11/16 PRC GO			08/02/1991	27/11/1997	29/06/1998

CHANGE HISTORY					RELATED DOCUMENTS		
Iss	Date	Remarks	Chkd	Appr	# Documents	Issue	Notes
A	--/--/--	Initial Release					
B	23/06/1994	Spacer (Item 16) Added		TJK			
C	23/02/1996	Subs now have 4 spanner flats - Refer ECR 071		DJF			
D	22/12/1997	Items 6&7 now sub assys - Refer ECR 207		AJB			
E	29/06/1998	Items 2,14&15 Upissued or changed		AJB			
F	20/11/2001	Splash Proof Sealing added - Refer ECR 940	AJB	TLS			
G	11/03/2002	Item 33 Removed - Refer ECR 1076	IH	TLS			

PARTS LIST							
Item	Part No.	Issue	Description	Component Value	Qty	Units	Remarks
001	00502	D	Shaft Main 9 5/8 Centraliser with Feedthrough		1	ea	
002	00536	D	Assy Rod Connecting (Elec)		1	ea	
003	00504	E	Lower Sub, 1 11/16		1	ea	
004	00503	E	Upper Sub, 1 11/16		1	ea	
005	00501	K	Body Centraliser 1 11/16		2	ea	
006	00563-3	D	Assy Centraliser Arm Lower Winged		3	ea	
007	00562-3	D	Assy Centraliser Arm Upper Winged		3	ea	
008	00506	J	End Cap, Body		2	ea	
009	00505	G	Thrust Plate, Spring Collar		2	ea	
010	00513	C	Pin Collar PRC		2	ea	
011	00509	D	Spacer, Centraliser Arm		3	ea	
012	00512	E	Axle, Centraliser Roller		3	ea	
013	00508	C	Roller, 0 5		3	ea	
014	08518	A	Insulator, Upper, GO, 1-3/8 To 1-11/16 (PRC Splash Sealing)		1	ea	
015	01010	A	Insulator Peek 80o		1	ea	
016	08514	A	Insulator, Lower, GO, 1-3/8 To 1-11/16 (PRC Splash Sealing)		1	ea	
017							
018	17025	PT1	ASSY- CLOSING RING TRANSPORTATION		1	EACH	
019	01030	A	Screw, Grub Skt Hd, M6 x 6mm Long, St/Steel		2	ea	
020	91000	-	Bearing Ball 3/16 Hard		6	ea	
021	01063	A	Screw, Grub Skt Hd, M6 x 8mm Long, St/Steel		6	ea	
022	00531	A	Spring Compression 2.5lg x1.218 OD Rate 133lbs/in-Music Wire		2	ea	
023	00532	A	Spring Compression 3 lg x 0.846 OD Spring rate 35.63 lbs/in		2	ea	
024	00522	A	Spring Compression 40lbs (Use 91200)		2	ea	
025	01040	A	Pin, Spirol, 3/16 x 7/8 Lg, St/Steel		6	ea	
026							
027	01034	A	Screw, Skt Cap Hd, M5 x 16mm Long, St/Steel		3	ea	
028	01058	A	Bush DU 1/4 x 5/16 x 3/8		3	ea	
029	99012	-	O Ring Viton 90 Type 012		4	ea	

<b>PARTS LISTING</b>					
Part:  02009	Issue:  G		Drawn:  DO	Checked:  NGH	Approved:  AJB
			Date: 08/02/1991	Date: 27/11/1997	Date: 29/06/1998
Description: Assy 1 11/16 PRC GO					

<b>PARTS LIST</b>							
Item	Part No.	Issue	Description	Component Value	Qty	Units	Remarks
030	91001	-	Nipple Grease M6 Straight		1	ea	
031	00535	A	Insulator PTFE Central Shaft Feedthrough (535 mm)		1	ea	
032	99211	-	O Ring Viton 90 Type 211		2	ea	
033							
034	01026	-	Half-Nut, Hex, 10-32UNF, St/Steel		1	ea	
035	01028	C	Assy, Banana Pin (4mm)		1	ea	
036	00554	A	Spacer Shaft		2	ea	
037	08529	A	Retainer, Seal (PRC Splash Sealing)		1	ea	
038	99923	-	O Ring 7mm x 1mm Nitrile 70 (7mm ID x 1mm CS)		1	ea	
039	95008	-	O Ring Viton 75 Type 008		2	ea	
040	95012	-	O Ring Viton 75 Type 012		1	ea	

(AR = As Required)