

What is a PCE and the used of them

STUFFING BOX

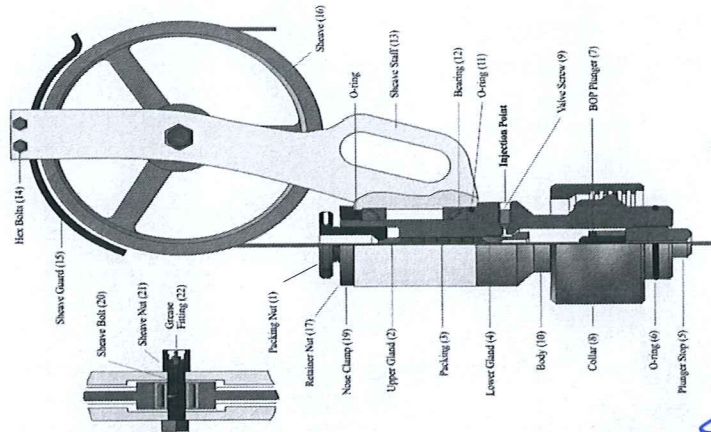

WIRELINE BLOWOUT PREVENTERS

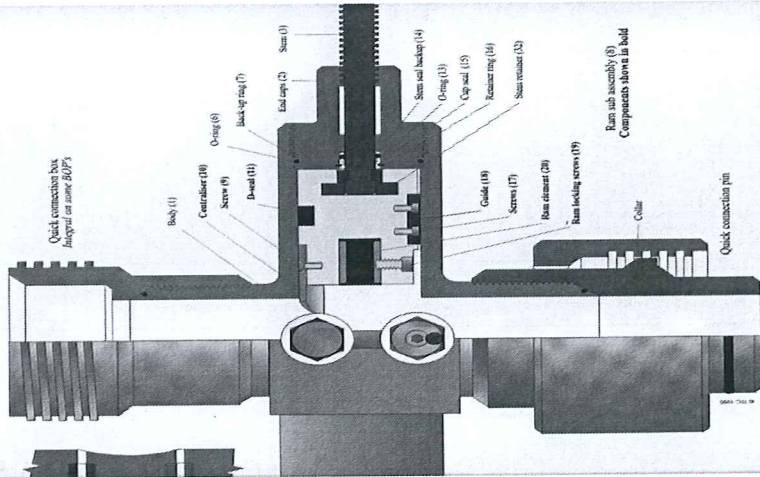

QUICK UNIONS

The connections used to assemble the wireline service lubricator and related equipment are referred to as 'Quick Unions', and they are designed to be assembled by hand. 2 types in common use are 'Otis' and 'Bowser' designs.

An O-ring on the pin section forms the seal when made up into the box. The collar has an internal ACME thread to mate with the internal thread on the box. The thread locks up quickly by hand and should be kept clean. The O-ring should be thoroughly inspected for damage - replace if necessary - before use. A light film of oil (or grease) helps to make up the union and prevent damage to the O-ring as the connections are made up.

When the collar is made up, it should be backed off approximately one quarter turn to eliminate any possibility of it sticking due to friction when it is to be removed.

Pipe wrenches, chain rings, or nutrunners, should never be used to loosen the collar of this union. If it cannot be turned by hand, precautions must be taken to make sure that the **well pressure has been completely released!**

Rocking the lubricator to ensure it is perfectly straight will assist in loosening the quick union.

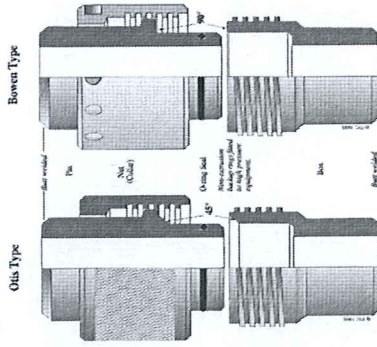

Note: Differences between Otis and Bowser are:

- (i) External - holes.
- (ii) Internal - angles.
- (iii) Pin diameter (Otis 3.5", Bowser 4.75").

WIRELINE BLOWOUT PREVENTERS

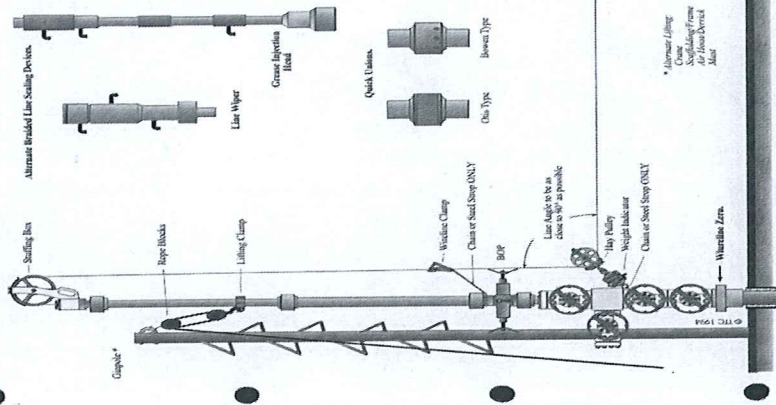

Stuffing Box

1. Sealing device to determine by type of well and well pressure/fluid.
 - Stuffing Box for Slick line
 - Swabbing Head for Braided Line
 - Grease Injection Head for Braided line high pressure seal.
- **Purposed**
 - Design Features to ensure sealing off around wireline at upper of lubricator.
 - To hold the pressure while in wireline operation
 - Stuffing box is designed to trap wire which breaks on surface before it drop down.



B. SURFACE EQUIPMENT

1. Stuffing Box

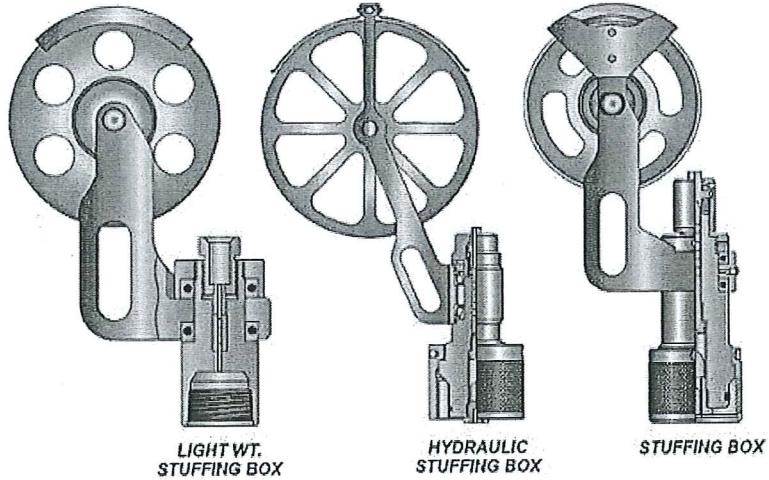

What is Stuffing Box

Sealing device to determine by type of well and well pressure / fluid.

- Stuffing box for slickline
- Scrubbing head for braided line
- Grease injection head for braided line high pressure seal.
- Primary Barrier

What is the purpose of stuffing Box

- Design features to ensure sealing off around wireline at upper of workstring
- To hold pressure while in wireline operation
- Stuffing box is designed to trap wire which breaks on surface before it drop down.

How to operate Stuffing Box

- Pressure (Hydraulic Hand Pump)
- Packing Nuts

What is maintenance required for Stuffing Box

- Upper gland - O ring
- Lower gland - BOP Plunger
- Packing

What is safety precaution required for Stuffing Box

- Proper lifting technique
- Make sure stuffing box in good condition and certified, should be visually checked

CA



What is potential hazard during handling Stuffing Box

- Drop
- Wrong technique
- Pinch point.

Draw & name each part of stuffing box

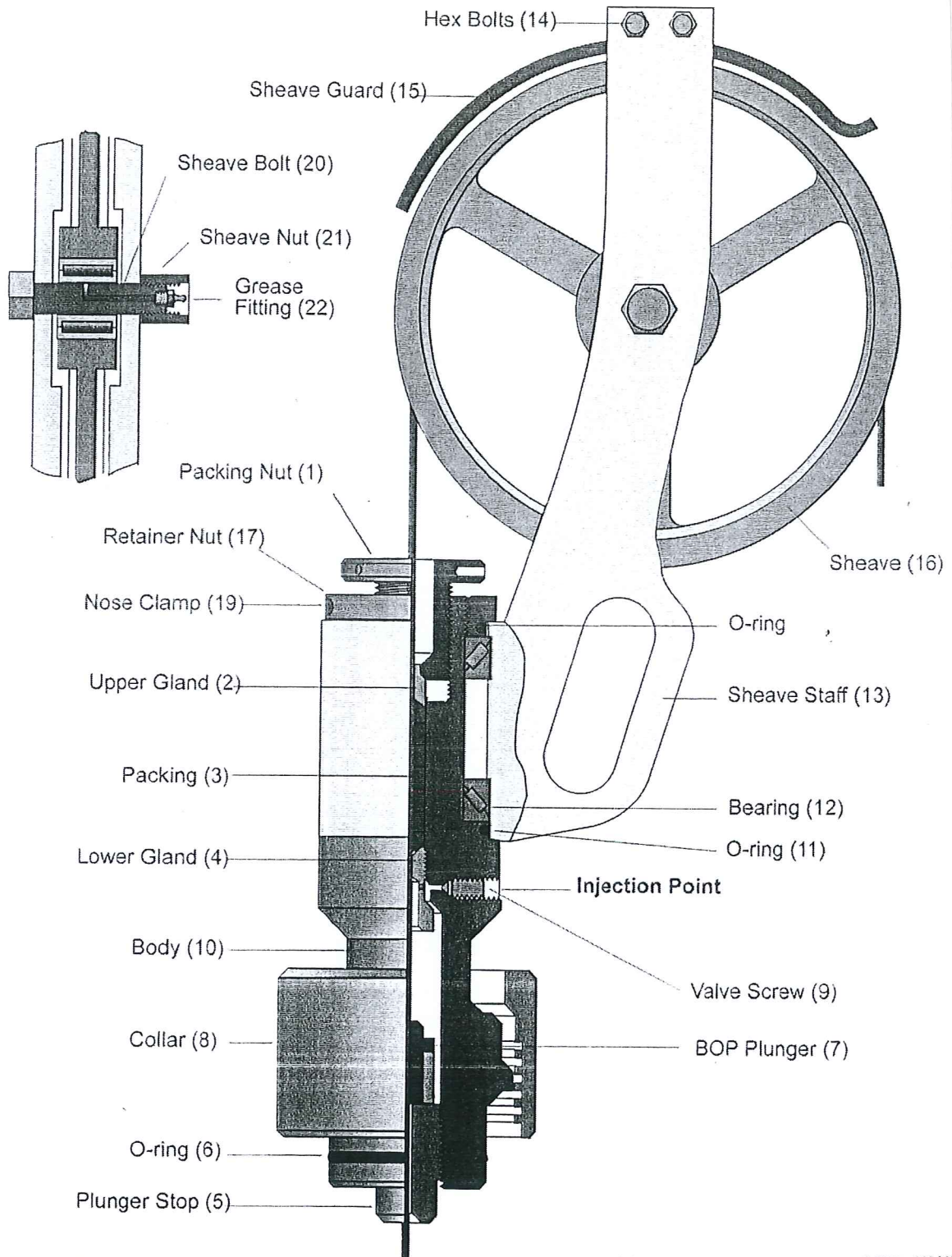



2. Lubricator

What is Lubricator

The lubricator enables wireline tool strings and equipment to be inserted and removed from a well under pressure.

What is the purpose of Lubricator

- Release pressure
- Guide toolstring into well

How to operate Lubricator

- Using Chain Block, make sure lubricator in straight position before it connected.
- Must

What is maintenance required for Lubricator

- Coating
- Painting
- O ring
- Pressure Test

What is safety precaution required for Lubricator

- All Lubricators should be X-rayed, magna-flamed for cracks and visually inspected at the regular intervals.
- Make sure pressure was release before operate.

What is potential hazard during handling Lubricator

- Drop
- Gas Leaking
- Pinch Point.

AM



Draw & name each part of Lubricator

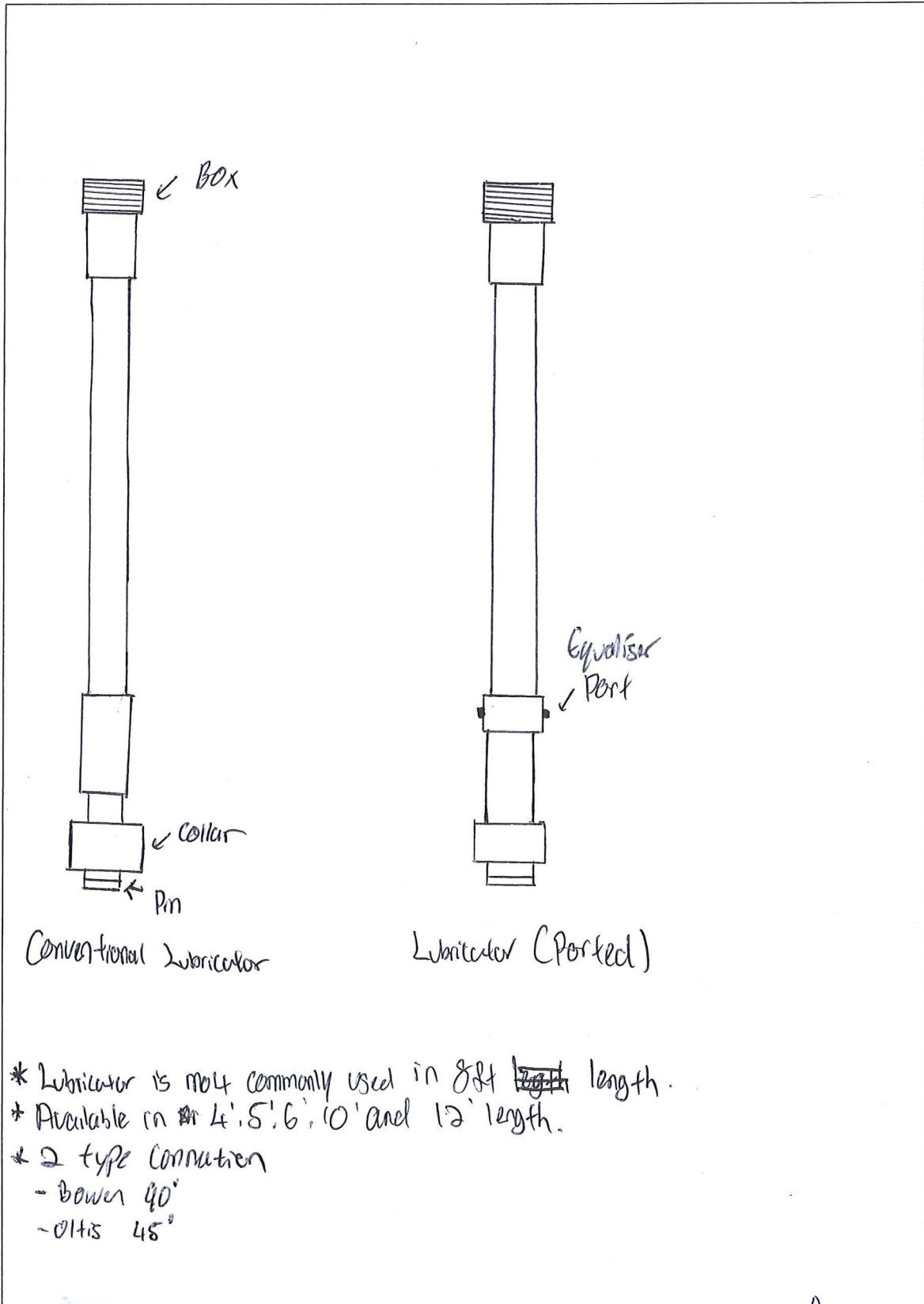

CA

BOP- Blowout Preventer

BOP is installed between and lower Lubricator section.

- Bop Rating 5K equipped with 5-4 Px8 ACME Threads connection.
- Bop Rating 10K equipped with 5.75 Px8 ACME Threads connection.
- Bop ID bore is 2.99”.
- To enable well pressure to isolated without cutting wire by closing the master valve.
- Permit the assembly of the wireline cutter above BOP rams.
- The Rams holding pressure from both top and bottom.



3. Blowout Preventer (BOP)

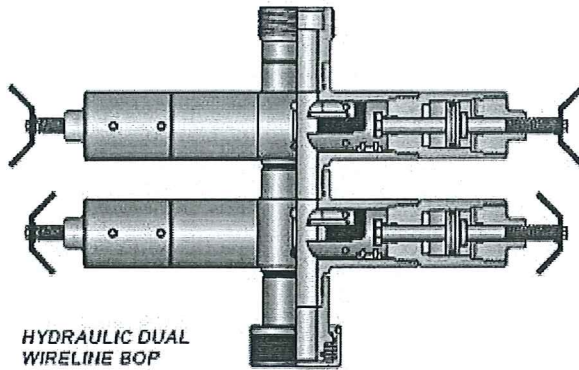

HYDRAULIC DUAL WIRELINE BOP

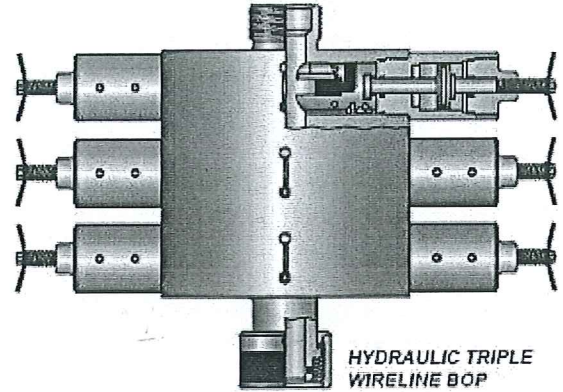

HYDRAULIC TRIPLE WIRELINE BOP

What is BOP

- BOP is installed between the tree connection and lower lubricator section
- Hold pressure from one direction only
- Secondary barrier for wireline operation

What is the purpose of BOP

- To enable the well pressure to be isolated without cutting the wire.
- To permit the assembly of the wireline cutter above the BOP rams.
- To permit 'stripping' of the wire through closed rams, only when necessary.

How to operate BOP

- Hydraulic pressure
- Control by Control panel
- Reed Switch Unit.

What is maintenance required for BOP

- Inner Seal
- Outer Seal
- O Ring

What is safety precaution required for BOP

Check visually with the rams open by locking down past the rams for the key way slot on the pressure (bottom) side of the body.

CA

Christopher Mathew



What is potential hazard during handling BOP

- Wrong operation technique
- Drop
- Struck by BOP

Draw & name each part of BOP

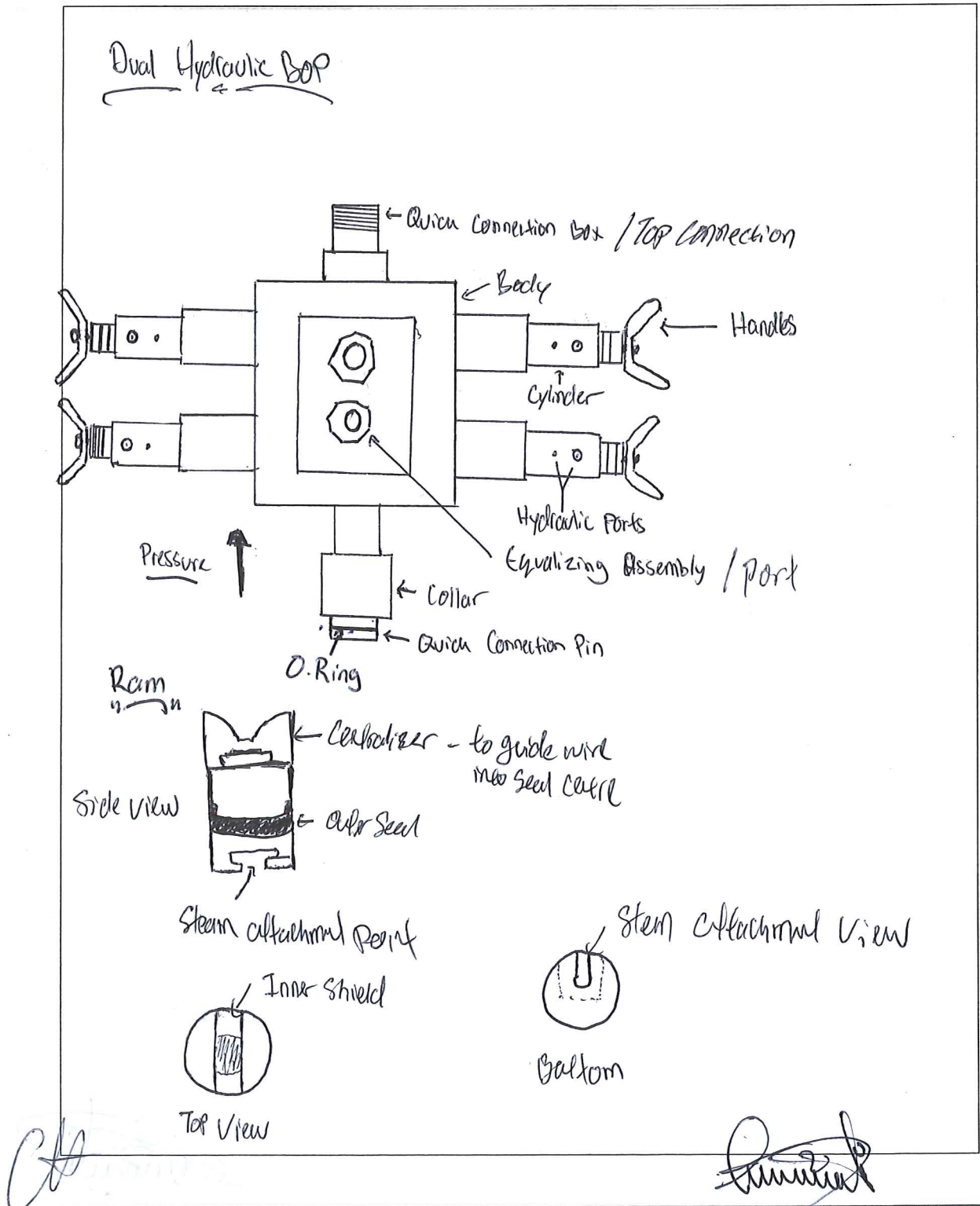

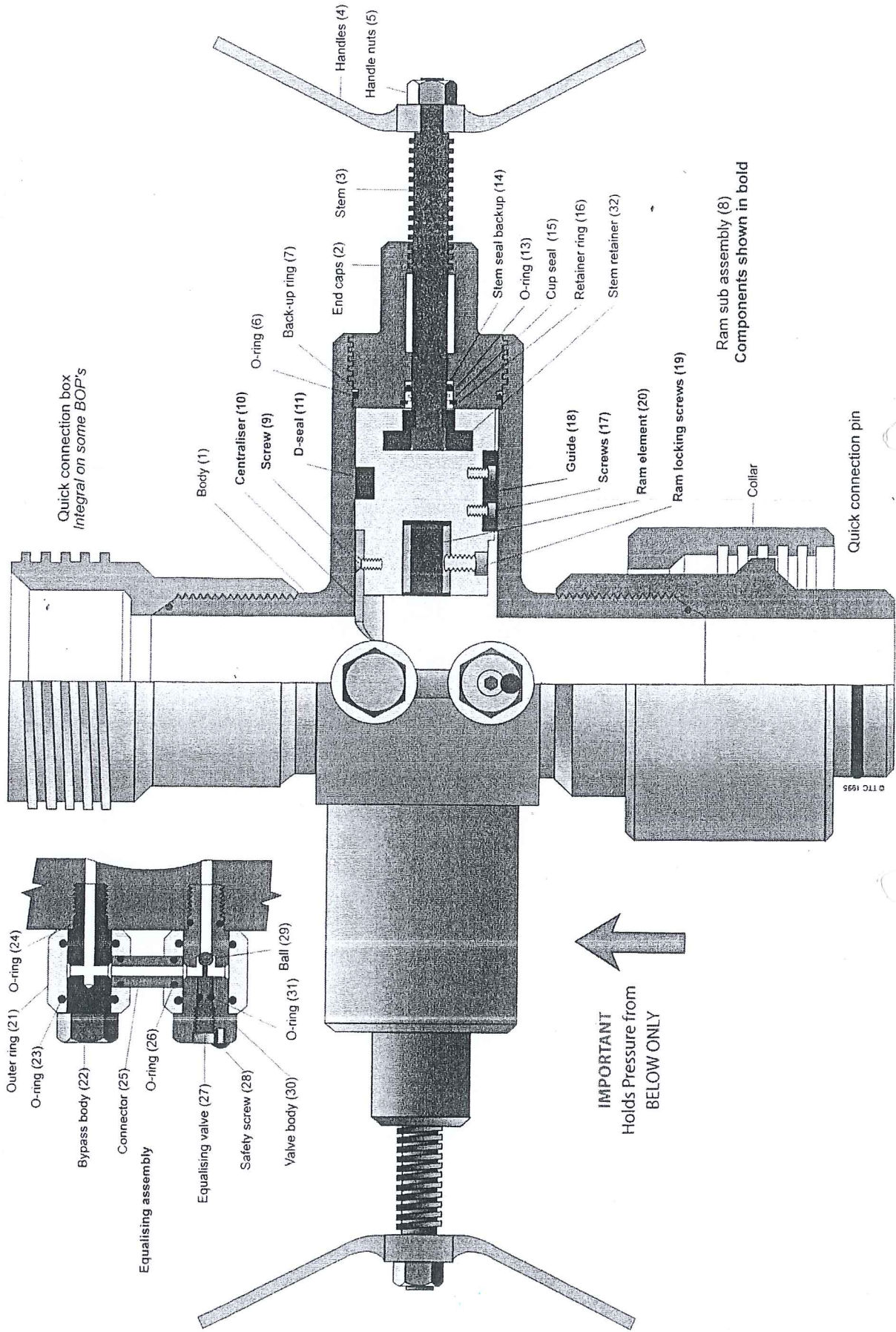

X-Mas Tree

Single Xmas Tree

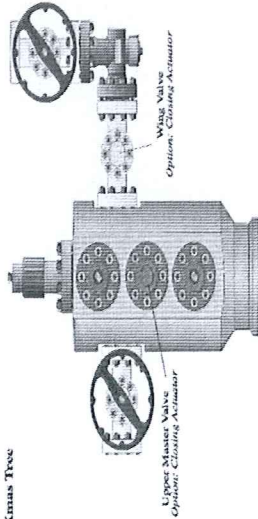

Dual Xmas Tree

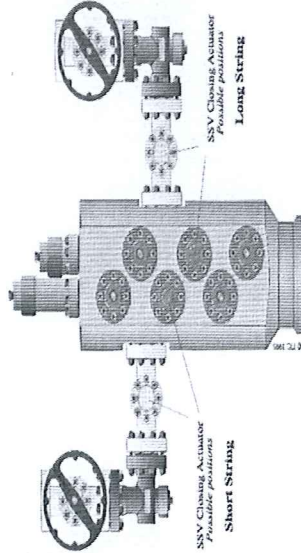

Surface Safety Valve actuators are mounted on reverse acting Xmas tree gate valves. (Flow line valves are not reverse acting and operate in the opposite direction.) Reverse acting gate valves are closed when the stem protrudes.

The actuators can be fitted on the upper master and / or production wing valves. It is usual to have a manually operated master valve as the lowest valve on the tree.

The actuators can be:

Pneumatic Air operated actuators are common on land wells and / or where there is plenty of space. They are the largest in diameter and usually operate at 80 to 120 psi.

Hydraulic Oil operated actuators are smaller in diameter and are used in confined spaces, such as on offshore platforms. They usually operate at around 3,000 psi.

The option exists with many valve / actuator manufacturers to have sufficient force in the actuators to cut wireline in an emergency to isolate well fluids.

It is advisable to utilise the lockout cap during wireline operations. Check the valid procedure for the specific area of operation.

After Wireline Operations Ensure the Xmas tree valves are back in service, with the lockout caps removed, so that the well safety system is active.

Advise the production personnel that the well is available for production as per the procedures in place for your area.

X-Mas tree

- The X-Mas is installed on the tubing spool is Surface Safety Valve to control the pressure from below.
- The X-Tree Consists below
 - A. Master Valve
 - B. Top Valve
 - C. Wing Valve
 - D. Flowline Valve
- Rating pressure 3000 PSI and 5000 PSI



4. X-Mas Tree

What is x-mas tree

X-mas tree is a series of valves installed on the wellhead to control the flow of fluid from the well.

What is the purpose of x-mas tree

- Pressure monitoring
- Pressure Sealing
- Control the flow of well

How to operate x-mas tree

- SWCP
- w/ Control Panel
- Always Count the turn (18 turn)

What is maintenance required for x-mas tree

- Lubrication of valves and actuator
- Corrosion and erosion inspection
- Pressure testing of valves

What is safety precaution required for x-mas tree

Do not over-tighten during opening or closing.

What is potential hazard during handling x-mas tree

- Pinch point
- Back Injury
- Grob leaks



Draw & name each part of x-mas tree

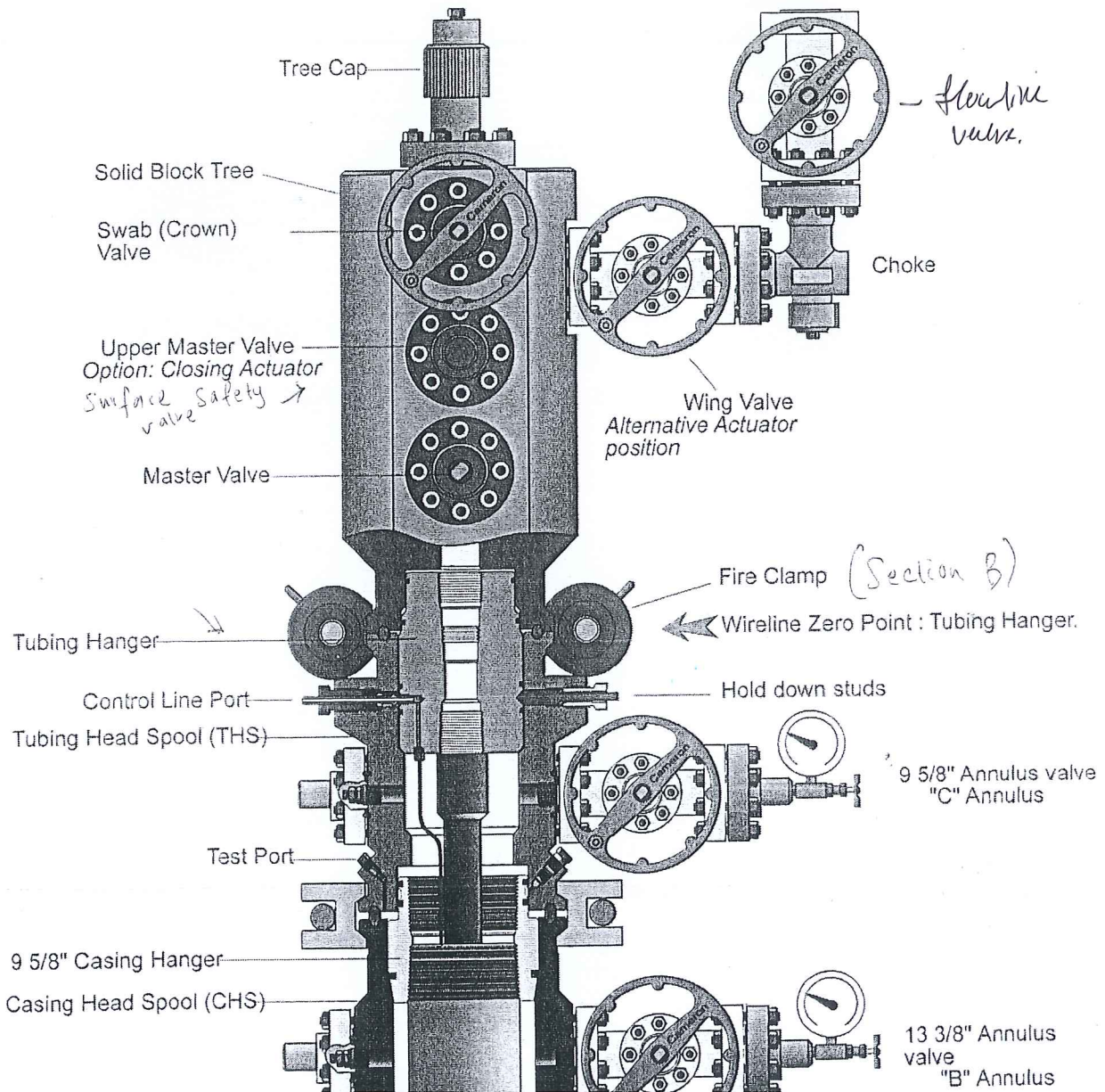
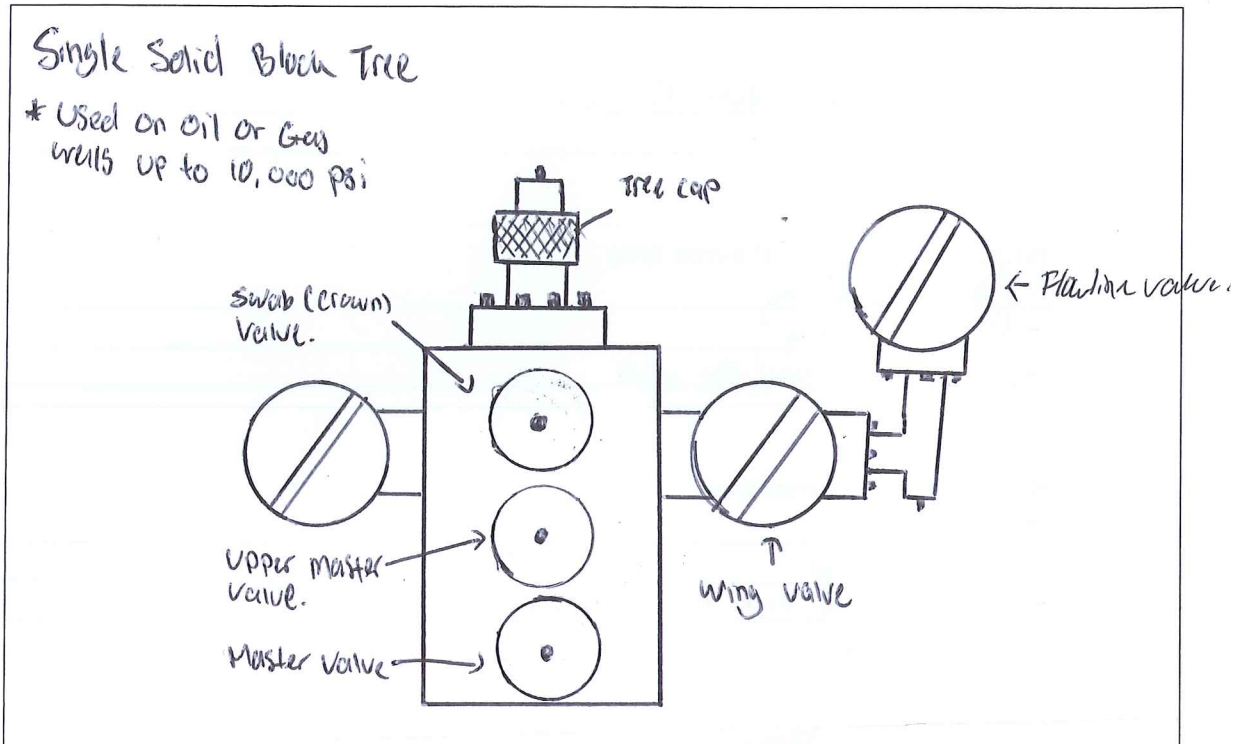

Power Pack and Reel Skid unit.

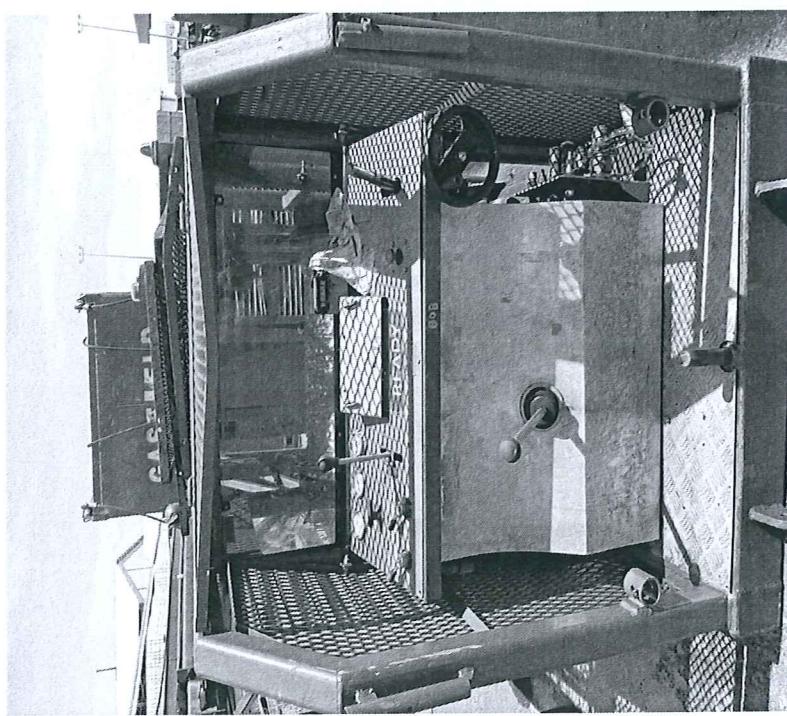
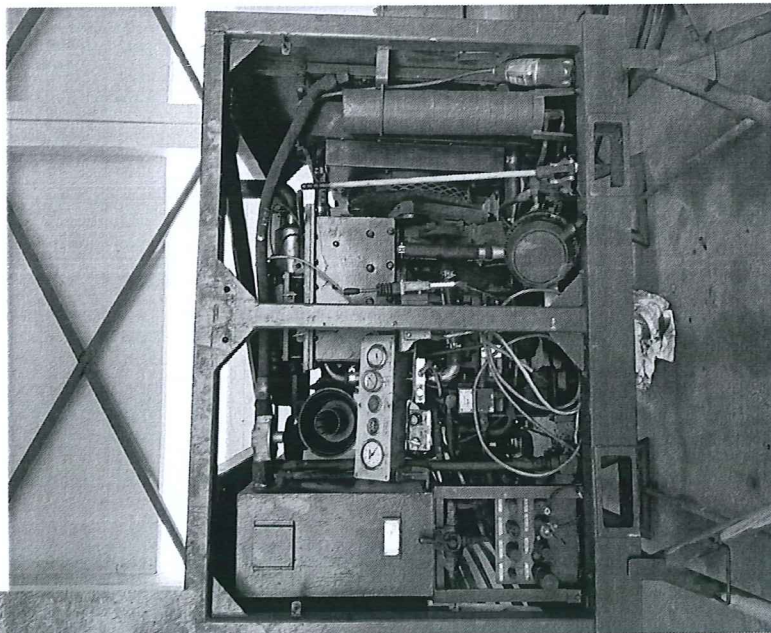
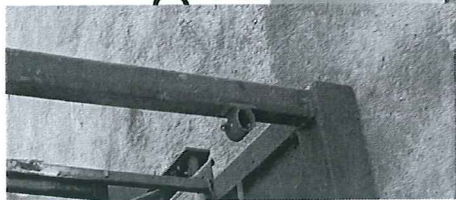

Reel Skid Unit (RSU)

- Certified With Zone 2
 - Equiped with Safety device.
 - Equiped with Weight indicator and Depth counter
 - Wire Drum.
 - Purposed
- To run down / pull out the wireline tool in the hole.



5. Wireline Reel Skid Unit (RSU) / Winch – Single Drum and Double Drum

What is RSU

A unit that have a drum that contain wire and a panel to control the drum direction and speed.

What is the purpose of RSU

Contain a drum which have a wire to lower down our tools and to pull the well accessories.

How to operate RSU

- By Power Pack (Hydraulic pressure)
- There is also a valve to control the hydraulic pressure.

What is maintenance required for RSU

- Hydraulic filter
- Check hose condition
- Cyclometer cable condition
- PRV

What is safety precaution required for RSU

- Always check hose condition before using RSU
- Watch for wire kink that might break.

What is potential hazard during handling RSU

- Hose burst
- Wire break
- Pinch point.



Draw & name each part of RSU

Wireline Unit (RSU)

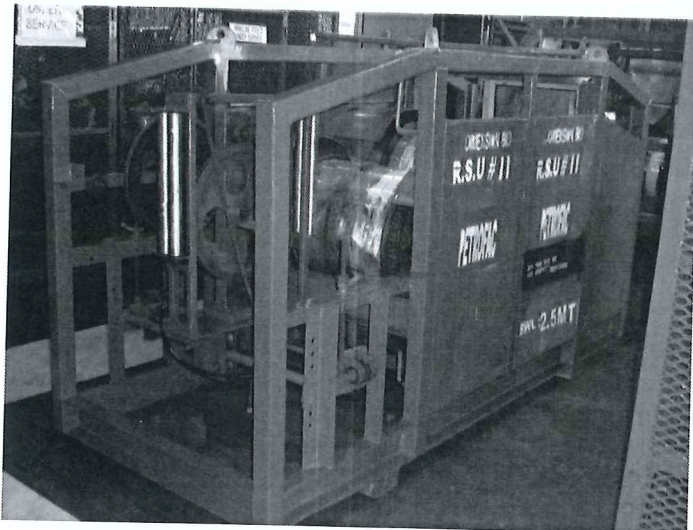



6. Odometer

What is Odometer

Odometer is a device that record and shows the current depth of our tools

What is the purpose of Odometer

To tell the current depth of our tools

How to operate Odometer

Connect the odometer to the odometer cable. The odometer have the ratio of 1:2. To reset the odometer (zeroing tool), there is a knob that can be turn to reset it.

What is maintenance required for Odometer

- Clean the cable with wd-40
- Spray the knob with wd-40

What is safety precaution required for Odometer

- Ensure the cable gland is tight
- Use glove when turning the knob

What is potential hazard during handling Odometer

- Pinch point
- Sharp point.

1 meter = 3.281 ft



Draw & name each part of Odometer



7. Weight indicator (200 lbs and 4000 lbs)

What is Weight Indicator

A device or system used to measure, display and record the weight of a tubing string

What is the purpose of Weight Indicator

Display and record the weight of a tubing string.

How to operate Weight Indicator

- Hydraulic

What is maintenance required for Weight Indicator

- Calibration
- Indicator Hydraulic
- Hydraulic Hose.

What is safety precaution required for Weight Indicator

- Check the hose make sure the hose in good condition
- Load Cell is heavy lift with precaution

What is potential hazard during handling Weight Indicator

- Pinch point
- Chain break off



Draw & name each part of Weight Indicator

Hey pulley and weight indicator

WIRELINE SHEAVES

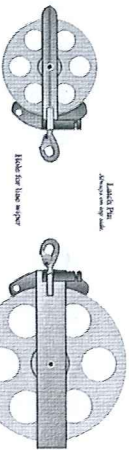

7" Hey Pulley

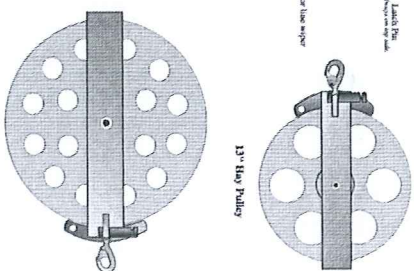

13" Hey Pulley

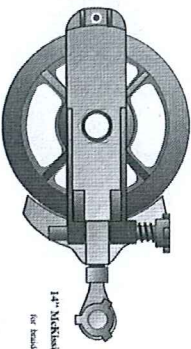

14" Mickelack Sheave for hoisted line

© 1975 The Matheson Instrument Division of The Matheson Company. All rights reserved. This document is the property of The Matheson Company. It is loaned to you for your use only. It is not to be reproduced, stored in a retrieval system, or transmitted in any form or by any means, electronic, mechanical, photocopying, recording, or by any information storage and retrieval system, without the prior written permission of The Matheson Company.

WEIGHT INDICATOR

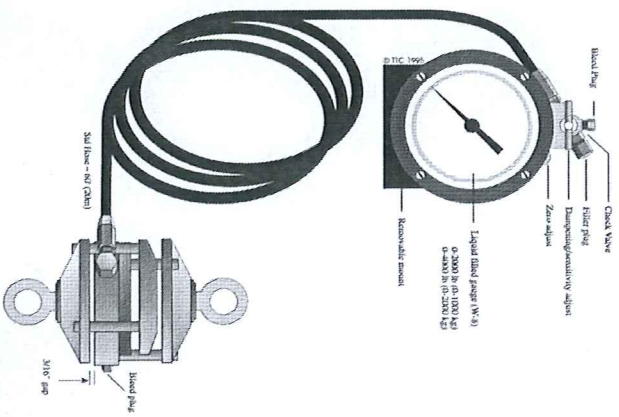

© 1975 The Matheson Instrument Division of The Matheson Company. All rights reserved. This document is the property of The Matheson Company. It is loaned to you for your use only. It is not to be reproduced, stored in a retrieval system, or transmitted in any form or by any means, electronic, mechanical, photocopying, recording, or by any information storage and retrieval system, without the prior written permission of The Matheson Company.

WEIGHT INDICATOR ANGLES

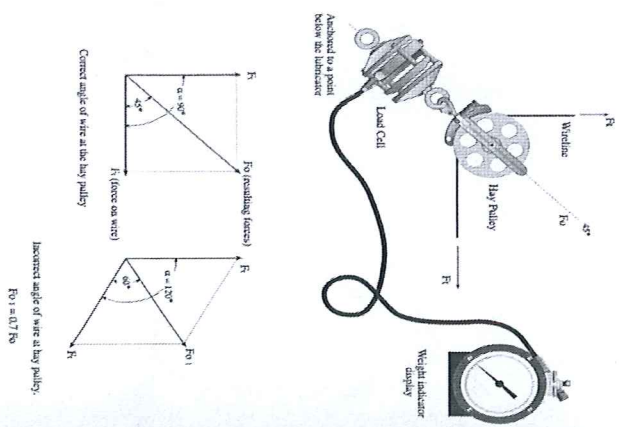

© 1975 The Matheson Instrument Division of The Matheson Company. All rights reserved. This document is the property of The Matheson Company. It is loaned to you for your use only. It is not to be reproduced, stored in a retrieval system, or transmitted in any form or by any means, electronic, mechanical, photocopying, recording, or by any information storage and retrieval system, without the prior written permission of The Matheson Company.

WIRELINE CLAMP

The Wireline Clamp used to clamp the wire to the indicator while raising or lowering it, or during operations when the weight has to be taken off the indicator unit (such as rearing the weight indicator or hauling off the tool for an extended period).
The clamp is usually fastened to a load off valve, located on the lower most indicator section by means of a short chain or wire link.
Take care not to kink the wire at any point during the rig-up, as this will cause a weak point which may break or slide in the setting box.

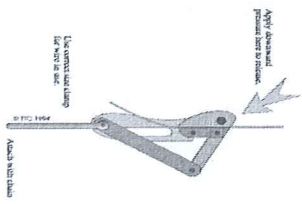

© 1975 The Matheson Instrument Division of The Matheson Company. All rights reserved. This document is the property of The Matheson Company. It is loaned to you for your use only. It is not to be reproduced, stored in a retrieval system, or transmitted in any form or by any means, electronic, mechanical, photocopying, recording, or by any information storage and retrieval system, without the prior written permission of The Matheson Company.



8. Spooling Device

What is Spooling Device

A device that hold the reel during spooling process

What is the purpose of Spooling Device

To hold the reel in spooling process. It also give proper tension during spool in (around 300 lb)

How to operate Spooling Device

Assemble the reel. The setup is almost the same with normal operation, which, weight indicator and heavy pulley is needed. Spooling device have a brake lever and that will help to control the line tension.

What is maintenance required for Spooling Device

- Brake maintenance
- Painting

What is safety precaution required for Spooling Device

- Always ensure flexi glass is in good condition
- Drum in good condition (Belt & nut) shaft.

What is potential hazard during handling Spooling Device

- Wire parted
- Pinch Point
- High decibel operation



Draw & name each part of Spooling Device

A large, empty rectangular box with a thin black border, intended for the student to draw and label the parts of a spooling device. There are some faint, illegible markings on the right side of the page, possibly from a previous page or a stamp.

What is control penal

Control Panel

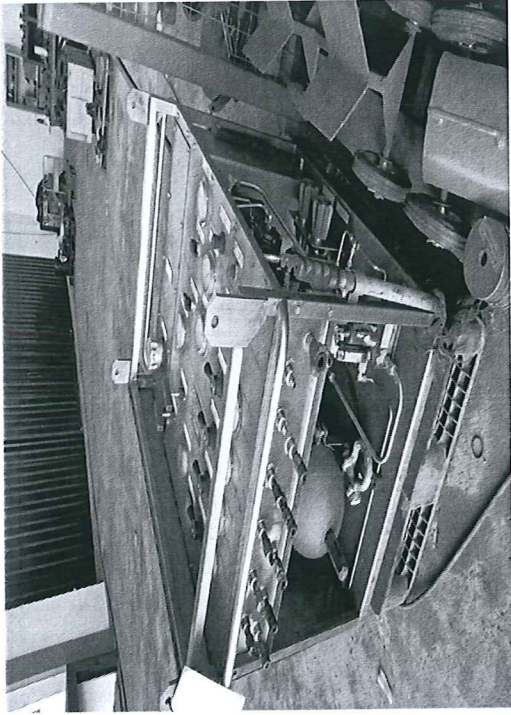
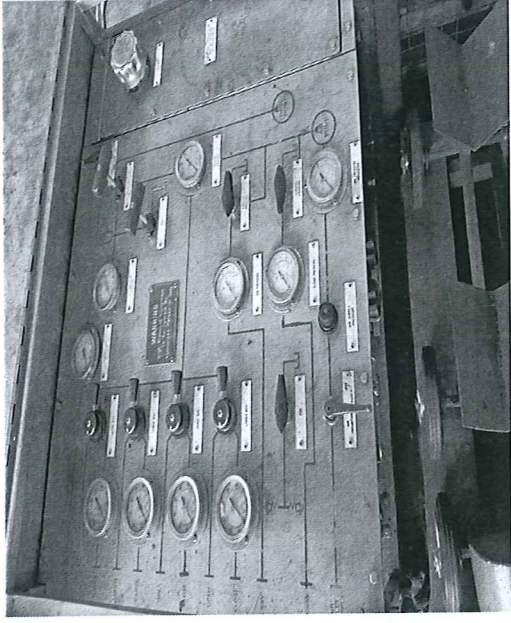

FIELD OPERATING & MAINTENANCE MANUAL

**WELL HEAD CONTROL UNIT
(2-BOP, SB, DHSV, MV & TEST LINE)
990062110
FOMM – PCU068(REV 01)**

*Dual BOP
Stuffing Box
Down Hole Safety Valve
Master Valve*

| REV. NO | DATE | PREPARED BY | CHECKED BY | APPROVED BY |
|---------|------------|-------------|------------|--------------|
| 01 | 13.04.2019 | Vijay | Saga | Zhao Yun Hua |

REVISION HISTORY

| Rev.No | DATE | CHANGES/ REASON | AFFECTED ZONE | RELEASED BY |
|--------|------------|--------------------|---------------|----------------|
| 01 | 13.04.2019 | First release | - | Sagadhevan |

CONTENTS

| SL.No. | DESCRIPTION | PAGE No. |
|--------------------|--|----------|
| SECTION - 1 | SAFETY | 6 |
| 1.1 | GENERAL | 6 |
| SECTION-2 | DESIGN PRINCIPLE | 7 |
| 2.1 | GENERAL | 8 |
| 2.2 | FEATURES | 9 |
| 2.3 | SPECIFICATIONS | 10 |
| 2.4 | PHYSICAL CHARACTERISTICS | 11 |
| 2.5 | OVERALL DRAWING | 12 |
| SECTION- 3 | CONTROL PANEL AND OPERATION PROCEDURE | 13 |
| 3.1 | CONTROL PANEL DRAWING / BILL OF MATERIAL | 14 |
| 3.2 | GENERAL CHECK BEFORE OPERATION | 16 |
| 3.3 | FIELD OPERATION | 17 |
| 3.4 | BOP PRESSURE / FUNCTION TESTING | 18 |
| 3.5 | BOP HYD SYSTEM OPERATION INSTRUCTION | 19 |
| 3.6 | SV & MV PRESSURE / FUNCTION TESTING | 20 |
| 3.7 | SV & MV OPERATING INSTRUCTION | 21 |
| 3.8 | SB FUNCTION TEST BY HYD FPUMP & HAND | 22 |
| 3.9 | TEST LINE PRESSURE / FUNCTION TEST | 22 |
| SECTION - 4 | REGULATOR (P/N: 990031686, WILKERSON) | 23 |
| 4.1 | GENERAL INTRODUCTION | 24 |
| 4.2 | SPECIFICATIONS | 25 |
| 4.3 | RECALIBRATION | 27 |
| 4.5 | REPAIR KIT | 28 |

| SL.No. | DESCRIPTION | PAGE No. |
|--------------------|--|----------|
| SECTION - 5 | AIR FILTER (P/N: 990004052, NORGREN) | 29 |
| 5.1 | GENERAL INTRODUCTION | 30 |
| 5.2 | SPECIFICATIONS | 31 |
| 5.3 | DIMENSION | 32 |
| 5.4 | MODEL SPECIFICATION | 32 |
| 5.5 | INSTALLATION | 33 |
| 5.6 | MAINTENANCE | 33 |
| 5.7 | PERFORMANCE CHART | 35 |
| SECTION- 6 | HASKEL HYDRAULIC PUMP (DSTV-2 & ASF-150) | 36 |
| 6.1 | GENERAL INTRODUCTION | 37 |
| 6.2 | PRINCIPLE | 44 |
| 6.3 | OPERATION | 46 |
| 6.4 | MAINTENANCE | 50 |
| 6.5 | TROUBLE SHOOTING GUIDE | 50 |
| 6.6 | SEAL KIT INSTRUCTION | 54 |
| 6.7 | DRAWING FOR DSTV-52 & ASF-150 | 55 |
| SECTION - 7 | HYDAC HYDRAULIC BLADDER ACCUMULATOR (P/N:990037363) | 59 |
| 7.1 | DESCRIPTION | 60 |
| 7.2 | TECHNICAL SPECIFICATION | 63 |
| 7.3 | DIMENSION AND SPART PARTS | 65 |
| 7.4 | N2 GAS PRECHARGING KIT | 67 |
| SECTION - 8 | MAINTENANCE – OTHER COMPONENTS | 70 |
| 8.1 | RELIEF VALVES | 70 |
| 8.2 | NEEDLE VALVE | 70 |
| 8.3 | BALL VALVES | 71 |
| 8.4 | 4 WAY 3 POSITION DCV VALVE | 72 |
| 8.5 | HIGH/LOW PRESSURE SENSOR VALVE | 73 |
| 8.6 | HYDRAULIC INLINE FILTERS | 73 |

| SL.No. | DESCRIPTION | PAGE No. |
|---------------------|--|----------|
| 8.7 | CHECK VALVES | 74 |
| 8.8 | 1K PR. BUTTERFLY BALL VALVE (990033747): | 74 |
| 8.9 | Y-STRAINER, (990020544) | 75 |
| SECTION - 9 | HOSE REELS | 76 |
| 9.1 | PRINCIPLE | 77 |
| 9.2 | MAINTENANCE | 77 |
| 9.3 | 1/2" RIGHT HAND SINGLE HOSE REEL ASSY, 60FT, 200 PSI (990018012) | 78 |
| 9.4 | 3/8" RIGHT HAND TWIN HOSE REEL ASSY, 75FT, 6K PSI (990057605) | 80 |
| 9.5 | 1/4" LEFT HAND TWIN HOSE REEL ASSY, 150FT, 15K PSI (990063628) | 82 |
| 9.6 | 1/4" LEFT HAND SINGLE HOSE REEL ASSY, 100FT, 15K PSI (990038321) | 85 |
| 9.7 | 1/4" LEFT HAND SINGLE HOSE REEL ASSY, 150 FT, 6K PSI (990041403) | 87 |
| SECTION - 10 | REWINDING MECHANISM | 89 |
| 10.1 | PRINCIPLE | 90 |
| 10.2 | MAINTENANCE | 90 |
| 10.3 | LEFT HAND REWIND MECHANISM ASSY (P/N: 990052801) | 91 |
| 10.4 | DOUBLE REWIND MECHANISM DRAWING (P/N: 990043086) | 92 |
| SECTION-11 | TUBING FITTINGS & TUBE | 93 |
| 11.1 | TUBING FITTING | 94 |
| 11.2 | TUBING | 100 |
| SECTION - 12 | HOSES | 102 |
| SECTION - 13 | HAND PUMPS (P/N:990039620) | 103 |
| SECTION - 14 | RECOMMENDED SPARES | 104 |
| SECTION - 15 | MAINTENANCESCHEDULE | 105 |
| SECTION - 16 | HANDLING & INSTALLATION INSTRUCTIONS | 106 |
| SECTION - 17 | LIFTING SET | 107 |
| SECTION - 18 | DRAWING AND BILL OF MATERIALS | 108 |

SECTION 1 SAFETY

1.1 GENERAL

- Read operation and maintenance manual carefully before operating.
- Observe all safety precautions.
- This system is capable of producing high pressure response accordingly.
- On air driven units, to avoid component rupture and possible injury regulate inlet air pressure slowly. so outlet pressure does not exceed the maximum working pressure of any component in the set up.
- Check pressure rating and compatibility of all connections.
- Clear area of unnecessary personnel.
- Select proper equipment.
- Make sure valves and regulators are in correct position.
- Do not try to tighten or loosen connections under pressure.
- Do not weld, file or use metal stamps on the pressure equipment – these can start cracks.
- Do not overtighten any valves (hand tight only).
- Do not attach anything to this equipment unless you are sure of its pressure rating.
- Beware of trapped pressure. Bleed off fully before dismantling any connections.
- Pay attention to all safety and warning instructions on the machine.
- Always use appropriate personnel protective equipment.

SECTION 2 DESIGN PRINCIPLE

- 2.1 GENERAL
- 2.2 FEATURES
- 2.3 SPECIFICATIONS.
- 2.4 PHYSICAL CHARACTERISTICS
- 2.5 OVERALL DRAWING

2.1. GENERAL

- This RMZ Hydraulic control module is designed to operate DUAL RAM BOP, SB, SV, MV & TEST LINE (15K WP).
- Three air driven hydraulic pump (One DSTV-52 Pump for BOP & SB. Two ASF-150 pumps for SV, MV & TEST LINE). Four back-up hand pumps are provided in this circuit.
- Emergency shutdown facility provided.
- Two hydraulic hand pumps are used in SB & BOP circuits. The SB /BOP circuit supply hydraulic pressure up to 5,000 psi maximum pressure.
- Two hydraulic hand pumps are used in SV, MV & TEST LINE circuits. The SV/MV/TEST LINE circuit supply hydraulic pressure up to 15,000 psi maximum pressure.
- S.S integrated Hydraulic tank (55L + 20L) is provided.
- Low Hydraulic pressure Horn system has been provided for SV & MV.
- All hoses are mounted on RMZ "wet centre" reel, all tubing and many components are of stainless steel. All controls are mounted ergonomically on a stainless-steel mimic control panel.
- Emergency shutdown facility -Ball valve type has been provided to bleed hydraulic pressure on SV/MV hyd. line as immediately.

2.2. FEATURES

- Steel unit frame.
- Protective cover panels.
- 55L + 20L hydraulic oil reservoir.
- Machine engraved, stainless steel, colour coded panel.
- A clear & easy understanding stainless steel control panel is incorporated with the unit.
- Controls for SB, BOP, SV, MV and TEST LINE.
- Three air driven hydraulic pump for circuits.
- Back-up SS hand pump for circuit.
- Built –in hose reels with rewinding mechanism to allow ease of hoses handling
- Two 20L Accumulator and Relief valve in circuit.
- Air supply port.
- Hydraulic oil is supplied 3,000 - 5,000 psi pressure via port to DUAL BOP & SB.
- Hydraulic oil is supplied 15,000 psi pressure via port to SV, MV & TEST LINE.
- Optional Accumulator -N2 gas Precharge set up.

2.3. SPECIFICAION

- The HASKEL 57:1 high pressure pump, P/N: 990043509 (DSTV-52) supply 8.0L/min. at 5,000 psi with 150 psi max.air supply pressure, CW ATEX certification.
- The HASKEL 150:1 high pressure pump, P/N: 990038286 (ASF-150) supply 1.3L/min. at 15,000 psi with 150 psi max.air supply pressure, CW ATEX certification.

2.4. PHYSICAL CHARACTERISTICS

- The RMZ Hydraulic control module – 990062110 overall dimensions

Length = 56.0"

Width = 48.3"

Height = 65.7"

- Approximate weight:

Gross = 1800 kg

2.5. OVERALL DRAWING

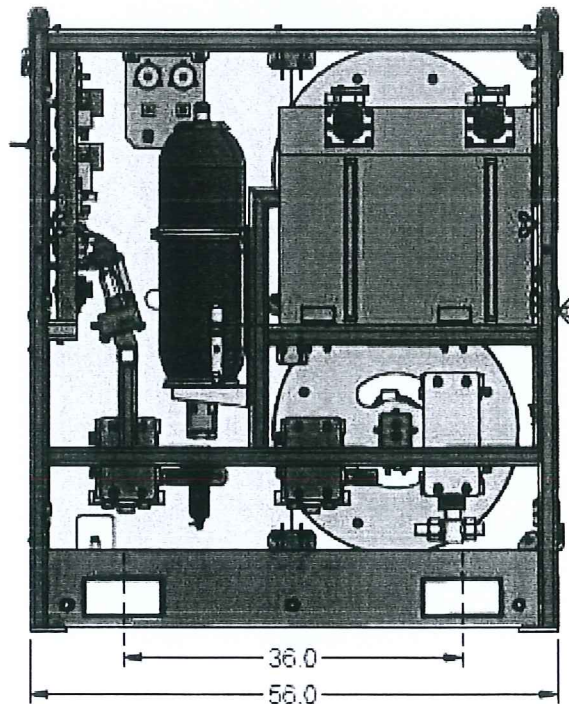
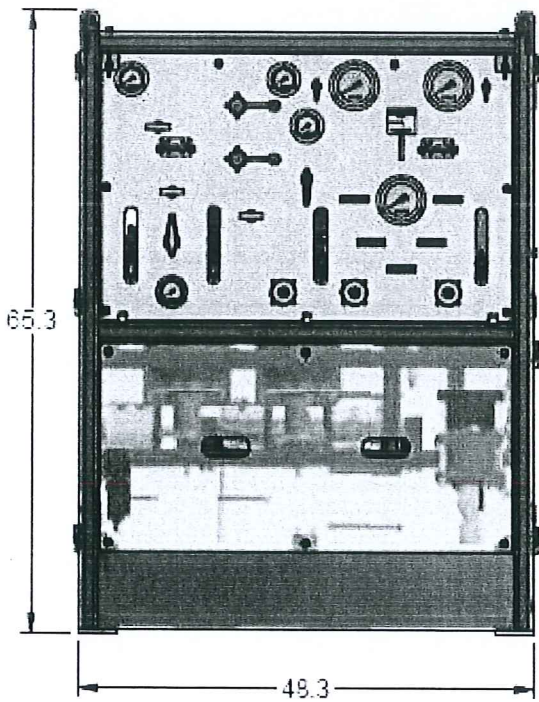
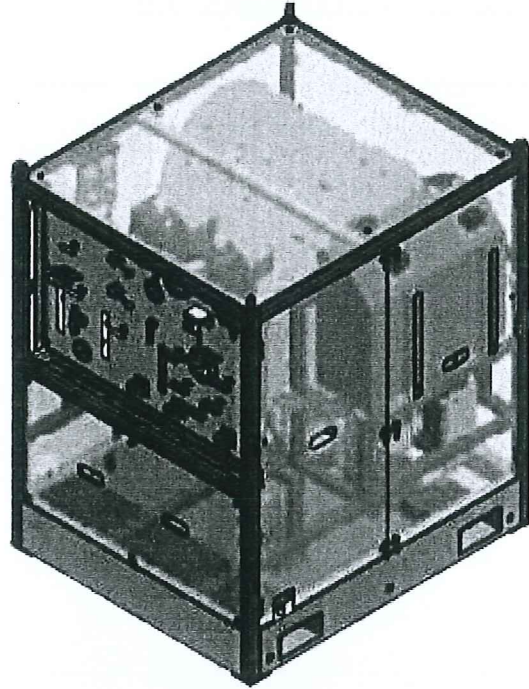
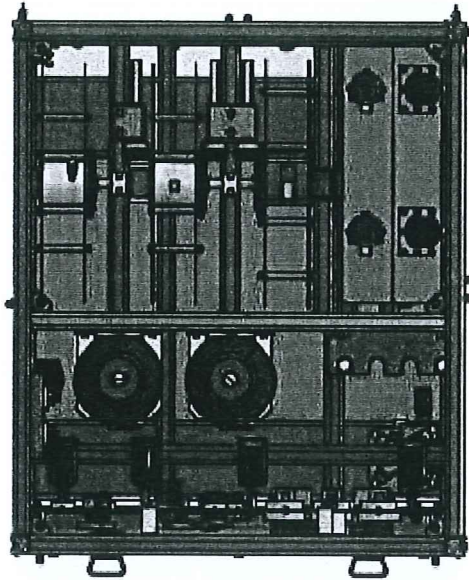

SECTION 3 CONTROL PANEL AND OPERATION PROCEDURE

- 3.1 CONTROL PANEL DRAWING / BILL OF MATERIAL
- 3.2 GENERAL CHECK BEFORE OPERATION
- 3.3 FIELD OPERATION
- 3.4 PRESSURE / FUNCTION TEST FOR BOP
- 3.5 BOP HYD SYSTEM OPERATION INSTRUCTIONS
- 3.6
 - a) PRESSURE / FUNCTION TEST FOR SV & MV
 - b) HORNING SYSTEM
 - c) EMERGENCY SHUTDOWN -BALL VALVE TYPE
- 3.7 SV & MV OPERATION INSTRUCTION
- 3.8 SB PRESSURE / FUNCTION TESTING BY HAND PUMP
- 3.9 TEST LINE PRESSURE / FUNCTION TESTING.

3.1 CONTROL PANEL DRAWING / BILL OF MATERIAL:

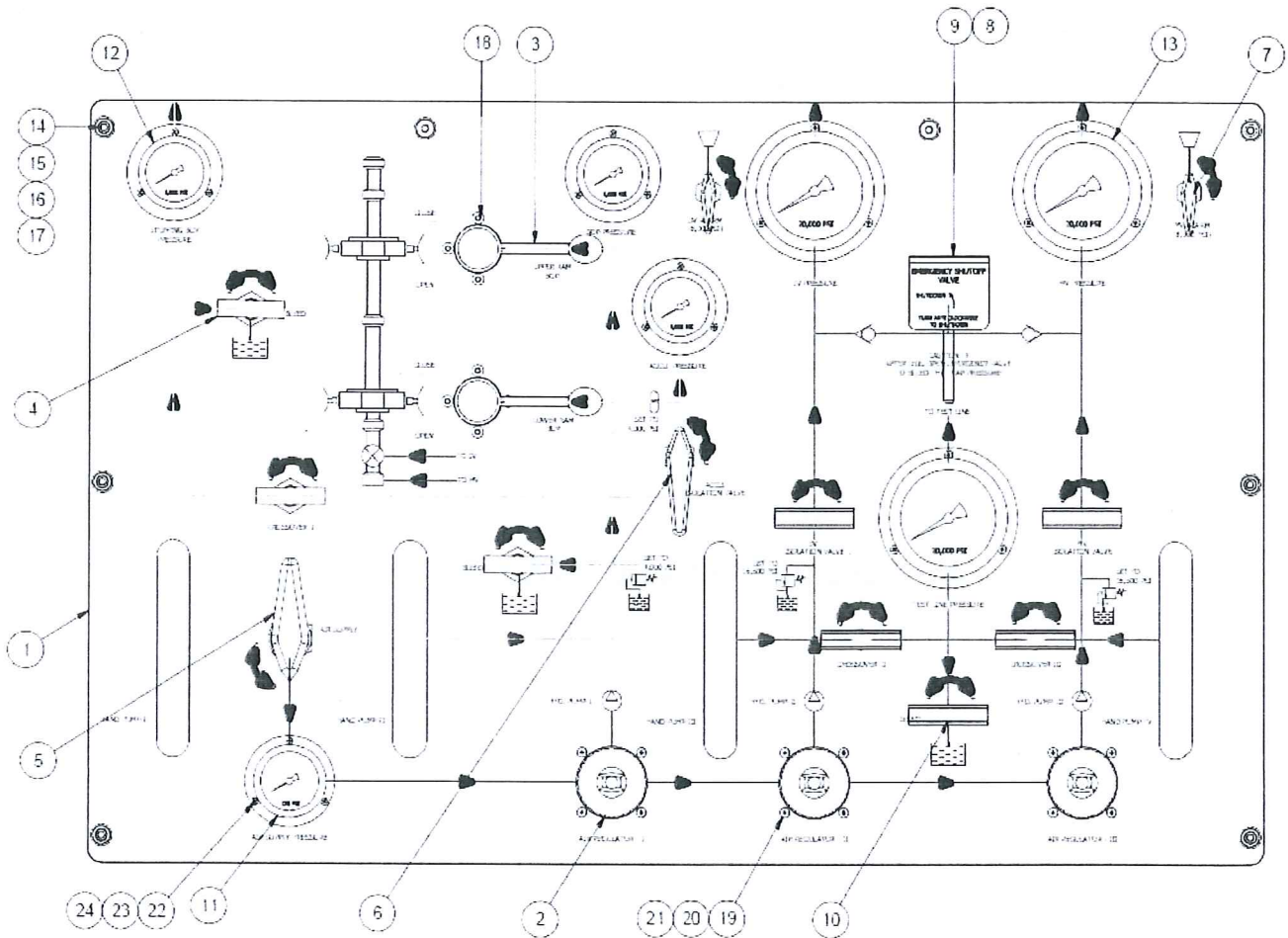

BILL OF MATERIAL:

| ITEM | PART NO | DESCRIPTION | QTY |
|------|-----------|----------------------------------|-----|
| 1 | 990063155 | CONTROL PANEL PLATE | 1 |
| 2 | 990031686 | AIR REGULATOR | 3 |
| 3 | 990023674 | 4 WAY 3 POSITION VALVE | 2 |
| 4 | 990024589 | NEEDLE VALVE | 3 |
| 5 | 990027503 | BALL VALVE | 1 |
| 6 | 990053060 | BALL VALVE | 1 |
| 7 | 990004044 | BALL VALVE | 2 |
| 8 | 990063661 | TRUNION BALL VALVE-2WAY | 1 |
| 9 | 990041346 | EMEGENCY VALVE COVER | 1 |
| 10 | 990024925 | NEEDLE VALVE | 5 |
| 11 | 990004041 | PRESSURE GAUGE | 1 |
| 12 | 990004043 | PRESSURE GAUGE | 3 |
| 13 | 990024992 | PRESSURE GAUGE | 3 |
| 14 | 990015431 | BUTTON HEAD SOCKET CAP SCREW | 8 |
| 15 | 990016365 | FLAT WASHER | 16 |
| 16 | 990003979 | SPRING WASHER | 8 |
| 17 | 990003978 | HEX NUT | 8 |
| 18 | 990001788 | BUTTON HEAD SOCKET CAP SCREW | 18 |
| 19 | 990025468 | CROSS RECESSED PAN MACHINE SCREW | 12 |
| 20 | 990028541 | LOCKNUT | 12 |
| 21 | 990019360 | FLAT WASHER | 12 |
| 22 | 990018086 | CROSS RECESSED PAN MACHINE SCREW | 12 |
| 23 | 990028539 | LOCKNUT | 12 |
| 24 | 990016357 | FLAT WASHER | 12 |
| 25 | 990028540 | CROSS RECESSED PAN MACHINE SCREW | 9 |
| 26 | 990020471 | LOCKNUT | 9 |
| 27 | 990016359 | FLAT WASHER, FOR #8 SCREW | 9 |

Important!!!

3.2 GENERAL CHECK BEFORE OPERATION

- Check hydraulic level through the level indicator.
- The airline filter is drained.
- Ensure that all air valves are OFF.
- Ensure that all needle valves and air regulators are CLOSE.
- Hand pump relief valves are CLOSED.
- Check all tubing, fittings etc., for any signs of damage. Replace as necessary.

3.3 FIELD OPERATION

3.3.1 RIG UP

- Place the skid with reels facing the rig
- Connect unit onto the relevant couplings on the rig. Inspect the valves and tubing for damage.
- Ensure that air supply to the pumps is OFF by turning the regulators on the control panel fully anti-clockwise.
- Connect unit to the air supply – max 150 psi.
- Check air pressure on the Air Pressure Gauge.
- Ensure crossovers are in OFF position.

3.3.2 RIG DOWN

- Set the air supply valve to OFF.
- Turn the hydraulic pump air regulators fully anti-clockwise.
- Open the BLEED valve for each circuit. This should release fluid pressure within the unit.
- Set the 4-way 3 position valves at OPEN position a few seconds, and turn to CLOSE position a few seconds, and then turn to BLOCK position. This should release fluid pressure in the hoses and tubing.
- Rewind hoses onto reels. Reels must not be rotated with pressure in the hoses. This will reduce "O" ring seal life.

3.4 BOP PRESSURE / FUNCTION TESTING

Danger: The following pressure tests are only carried out at up to maximum working pressure (MWP) of the systems in order to check for leaks and correct operation. Any testing above MWP should be carried out in a recognised pressure test bay.

3.4.1 BOP Pressure / Function test

- 1) Connect the air hose to air supply port.
- 2) Set all 4-way 3 position valves to BLOCK position.
- 3) Turn air regulator for BOP OFF (fully anti-clockwise).
- 4) Close the hydraulic bleed valve
- 5) Turn the accumulator valve to close position.
- 6) Turn the main air supply valve on.
- 7) Slowly turn air regulator for BOP clockwise until the max. Required pressure is reached.
- 8) Set the Upper RAM BOP 4-way 3 position valve to CLOSE. Check gauge for pressure. Check for leakage behind control panel and hose ends.
- 9) Set the Upper RAM BOP 4-way 3 position valve to OPEN. Check gauge for pressure. Check for leaks.
- 10) Set the Upper RAM BOP 4-way 3 position valve to BLOCK. Check gauge for pressure. Check for leaks.
- 11) Repeat Step 8) ~ 10) to other RAM 4-way 3 position valves.
- 12) Turn the BOP regulator off.
- 13) Turn the main air supply valve OFF.
- 14) Open bleed valve to release pressure to zero.
- 15) Set all 4-way 3 position valves to CLOSE position.
- 16) Turn the BOP isolation valve to open position.

3.4.2 Charge Accumulator

- 1) Set 4-way 3 position valves to Block position.
- 2) Turn the BOP isolation valve & accumulator valve to OPEN position.
- 3) Slowly turn air regulator for BOP clockwise until the desired pressure is reached. Check gauge for pressure. Check for leaks.
- 4) Turn the accumulator valve to the CLOSE position.
- 5) Turn air regulator for BOP OFF (fully anti-clockwise).
- 6) Open the BOP Bleed Valve.

3.4.3 BOP Pressure

Max. Working Pressure: 5,000 PSI.

3.4.4 Bop / Accumulator relief valve

Set BOP / Accumulator relief valve: 4,000 ~ 4,500 PSI.

3.5 BOP HYD SYSTEM OPERATION INSTRUCTIONS

(For Emergency operation)

3.5.1 Operation Instruction by Hydraulic Pump

- 1) Bop Hydraulic System Max. working pressure 5,000 PSI
- 2) Ensure all BOP 4-way 3 position valves are in BLOCK positions.
- 3) Ensure the BOP air regulator, located at bottom of panel, is OFF (fully anti-clockwise).
- 4) Ensure the bleed valve is in the CLOSE position.
- 5) Ensure the crossover valve is in the CLOSE position.
- 6) Set the 4-way 3 position valve to the OPEN position.
- 7) Turn the BOP air regulator slowly clockwise until the BOP Pressure gauge reaches the BOP operating pressure.
- 8) The BOPs may now be operated by moving the BOP 4-way 3 position valves to either the OPEN or CLOSE position

3.5.2 BOP OPERATION by Hand Pump

(Emergency operation)

- 1). In case of the air supply failure, the hand pump can be utilised.
- 2). Open the BOP isolation valve.
- 3). Turn the air regulator fully anti-clockwise (OFF)
- 4). Ensure that the bleed valve is in the CLOSE position.
- 5). Ensure that the MV isolation valve is in the close position.
- 6). Ensure that 4-way 3 position valve is set to the CLOSE position.
- 7). Operate hand pump and maintain operating pressure on the BOP Pressure gauge.
- 8). Control the BOP using the appropriate 4-way 3 position manual valve (pull the locking knob on the valve before moving the handle).
- 9). Depressurize the hydraulic system by opening the bleed valve.

3.6 a) PRESSURE/FUNCTION TEST FOR SV & MV

- 1) Turn the MV & SV air regulator fully anti-clockwise (**OFF**)
- 2) Ensure that the bleed valve is in the close position.
- 3) Ensure that the BOP isolation valve is set to the **close** position.
- 4) Slowly turn MV & SV air regulator clockwise until the max. Required pressure is reached.
- 5) Set the SV & MV isolation NEEDLE VALVE to **CLOSE**. Check gauge for pressure. check for leaks.
- 6) Turn off air regulator (fully anti-clockwise).
- 7) Open the bleed valve.

b) HORNING SYSTEM

- 1) Before to start the system, turn the horning ball valve to **close** position.
- 2) When the system pressure reaches stable, Turn the horning ball valve to **open** position.
- 3) When the MV pressure less than 8,000 PSI, the Horning alarm will be responding.
- 4) When the SV pressure less than 8,000 PSI, the Horning alarm will be responding.

c) EMERGENCY VALVE

- 1) When the system working normal, the emergency shutdown system -Ball valve should be in **closed** position.
- 2) When the system working abnormal, open the emergency shutdown valve cover and **Turn Ball valve in Anti-clockwise direction**. Thus, the HYD pressure in the system (SV/MV) will bleed immediately.
- 3) In case of Emergency valve malfunction, turn the Isolation valve(s) and crossover valve(s) to open position & bleed the hydraulic pressure thru Bleed valve in the SV/MV hyd. Line. The malfunction ball valve then to be replaced with careful consideration of trapped pressure.

Note: After completion of SV/MV operation, Turn the Emergency shutdown - Ball valve in anti-clockwise direction to bleed the trapped pressure of hydraulic oil & air in the system.

SYSTEM PRESSURES

SV / MV

Max SV working Pressure 15,000 psi
Max MV working Pressure 15,000 psi

LOW PRESSURE HORNING

Set SV alarm Pressure 8,000 psi
Set MV alarm Pressure 8,000 psi.

3.7 SV / MV OPERATION INSTRUCTION.

3.7.1 SV / MV OPERATION BY HYDRAULIC PUMP

- 1) Close the Bleed Valve
- 2) Close / open the crossover according to MV / S.V operation.
- 3) Open isolation valve according to MV / S.V operation.
- 4) Operate the air reg-II/air reg – III clockwise & watch the pressure of hydraulic in S.V/ M.V pressure gauge.
- 5) Use the hydraulic pressure to operate S.V / M.V.
- 6) Depressurize the hydraulic system by opening the bleed valve.
- 7) Use emergency valve to quick stop the operation.
- 8) MV Max. working Pressure: 15,000 PSI
- 9) SV Max. working Pressure: 15,000 PSI.

3.7.2 SV / MV OPERATION BY HAND PUMP

- 1) Close the Bleed Valve & BOP isolation valve.
- 2) Close MV & SV block valve.
- 3) Operate hand pump and maintain operating pressure on the SV & MV pressure gauge.
- 4) Control the SV & MV using the appropriate needle valve. Check gauge for pressure. Check for leaks.
- 5) Depressurize the hydraulic system by opening the bleed valve
- 6) MV Max. working Pressure: 15,000 PSI
- 7) SV Max. working Pressure: 15,000 PSI

3.8 SB PRESSURE / FUNCTION TESTING BY HYDRAULIC PUMP & HAND PUMP

- 1) Unwind the SB hose before pressure testing. Check the condition of all hoses ends, hoses and quick couplings. These should all be in good condition.
- 2) Close the crossover valve.
- 3) Set the hand pump needle valve to SB function and close crossover needle valve.
- 4) Operate air regulator/ hand pump and maintain operating pressure on the SB pressure gauge.
- 5) Control the SB using the appropriate needle valve. Check gauge for pressure. Check for leaks.
- 6) Depressurize the hydraulic system by opening the bleed valve.
- 7) SB pressure
Max. working Pressure: 5,000 PSI.

3.9 TEST LINE PRESSURE / FUNCTION TEST

- 1) Connect the air hose to air supply port.
- 2) CLOSE THE SV & MV isolation valves.
- 3) Open the crossover needle valve(s) for Test line.
- 4) Turn the air regulator(s) for Test line.
- 5) Close the hydraulic bleed valve.
- 6) Slowly turn the air regulator(s) clockwise until the max, required pressure is reached.
- 7) Maintain operating pressure on the gauge.
- 8) Check gauge for leaks.
- 9) Depressurize the hydraulic system by opening the bleed valve.
- 10) Test Line Pressure
- 11) Max. working Pressure: 15,000 Psi.

SECTION 12 HOSES

| DESCRIPTION | RMZ P/N | QTY |
|---|-----------|-----|
| 1/2" X 60 FT LG, AIR HOSE, 2000 PSI WP FOR AIR INLET | 990004940 | 1 |
| 3/8" X 75 FT LG, HYD SINGLE HOSE 5K PSI WP C/W API16D CERTIFICATE FOR BOP | 990056612 | 4 |
| 1/4" X 150FT LG, HYD SINGLE HOSE, 15K PSI WP FOR MV & SV | 990063687 | 2 |
| 1/4" X 100FT LG, HYD SINGLE HOSE, 15K PSI WP FOR TEST LINE | 990063683 | 1 |
| 1/4" X 150 FT LG, HYD SINGLE HOSE 5K PSI WP FOR SB | 990039766 | 1 |

SECTION 13. HAND PUMP

13.1 GENERAL

The Hydraulic hand pumps are a hand – held hydraulic sealant injection pump that is rated to 10,000 PSI & 20,000 psi used.

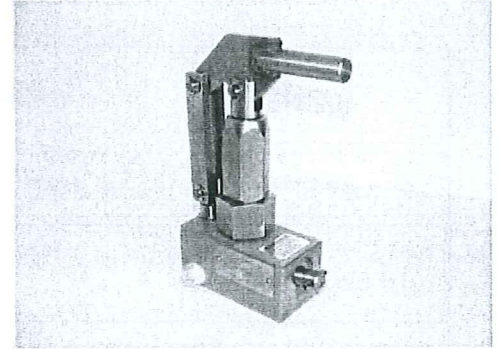

13.2 FEATURES

1. The hand pump made up of SS material.
2. Heat treated, ground and chrome plated pistons.
3. Gripped tubular steel handles
4. Release screws fine threaded for Vernier control
5. Seals compatible with petroleum-based fluids.
6. Excellent resistance to corrosion in marine & chemical processing.

13.3 SPECIFICATION

| | |
|--|---|
| Handle force required for rated pressure | : 191 Lbs for 10K& 210 Lbs for 20K Pump. |
| Volume / stroke | : 0.28 Cu. Inch & 0.16 Cu. Inch for 20K Pump. |
| Inlet & Outlet size | : 3/8 NPT |
| Net weight | :12 Lbs. |

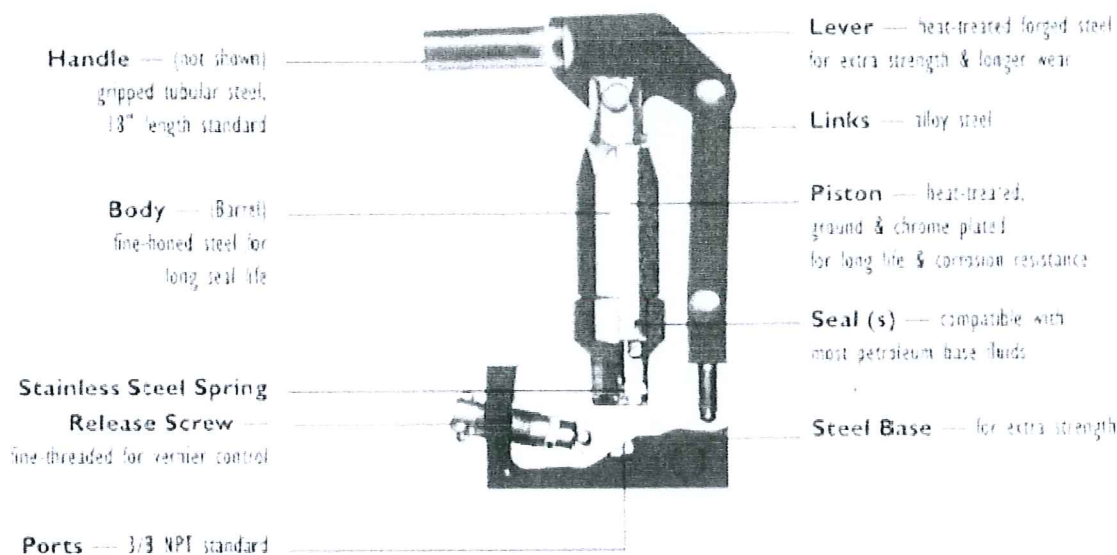

13.4 SEAL KIT:

- 10K RMZ HAND PUMP SEAL KIT P/N: 990039694.
- 20K HAND PUMP SEAL KIT P/N: 990064187

SECTION 14 RECOMMENDED SPARES

| DESCRIPTION | RMZ SPARE KIT P/N | QTY |
|--|-------------------------|-----|
| AIR REGULATOR – WILKERSON R21-04-000 (990031686) | 990025568 | 3 |
| AIR FILTER – NORGREN F74G-4AN-QP1 (990004052) | 990027301 | 1 |
| HYD.PUMP – HASKEL DSTV-52 (AIR DRIVE SEAL KIT) (SEAL KIT PACKAGE P/N:990041163) (AIR CYCLING VALVE) (FLUID SECTION) | 990020041 | 1 |
| | 990020094 | 1 |
| | 990041164 | 1 |
| HYD. PUMP- HASKEL ASF 150 (AIR DRIVE SEAL KIT) (SEAL KIT PACKAGE P/N: 990018133) (AIR CYCLING VALVE) (FLUID SECTION) | 990020093 | 2 |
| | 990020094 | 2 |
| | 990029513 | 2 |
| 20K HAND PUMP (9990033304) | 990064187 | 2 |
| 3/8"-4 WAY 3 POSITION DIRECTION CONTROL VALVE (OPTIONAL) | 990049512 | 2 |
| 10K RMZ HAND PUMP (990039620) | 990039694 | 2 |

SECTION 15 MAINTENANCE SCHEDULE

Refer to the relevant section in this manual for parts identification and disassembly / assembly instructions.

15.1 Daily:

- Check hydraulic fluid level
- Check low pressure warning system.
- Check ESD system condition.

15.2 Monthly:

- Disassembly air filter and clean thoroughly.
- Check hydraulic hoses & ends for any sign of leakage or damage.

15.3 Yearly

- Renew hydraulic tank and return filters.
- Disassembly hydraulic pump. Check for corrosion and wear.
- Disassemble hose reels if any seals are damaged replace with new.

SECTION 16: HANDLING & INSTALLATION INSTRUCTIONS

16.1 HANDLING INSTRUCTIONS:

Before handling of equipment, ensure following:

- ❖ Suitable protective clothing should be worn.
- ❖ Both hydraulic and pneumatic system pressures bled down.
- ❖ All control valves in close position.
- ❖ Fluid tanks filler cap in place and tightly secured.
- ❖ Drip tray in base of skid is drained and plug is in place and tightened.
- ❖ All associated pneumatic / hydraulic hoses are suitably stored away.
- ❖ Control panel protective cover in place and properly fastened.
- ❖ Lifting set shackles securely fastened to frame lifting eyes with safety split pins in place. Units must only be lifted using the correct 4-leg lifting set provided.

Note: Reference should also be made to Section 1.20 regards Safety and Potential Hazards identified at the Design Stage.

16.2 INSTALLATION INSTRUCTIONS:

Installation of the Well Control Unit in a workshop / platform is the responsibility of the equipment operator. However, the following should be taken into account:

- ❖ Unit to be placed on a level and firm surface which can hold the gross weight of the unit.
- ❖ The positioning of the unit with regards access for essential and non-essential maintenance.
- ❖ We recommend a minimum clearance distance of 1 metre all-round the unit.
- ❖ Routing of air and testing hoses from the unit to the equipment.
- ❖ The position of the control panel with regards operator access.

16.3 SOURCE'S:

- Air supply
 - ❖ Minimum pressure 90psi. (100psi required for 10,000psi Hydraulic Pressure)
 - ❖ Maximum Pressure 120~150psi.
 - ❖ Maximum Flow Rate 195scfm.
 - ❖ Connection type, 1/2" Crows Foot.
- Hydraulic supply
 - ❖ NOT APPLICABLE
- Electrical power supply
 - ❖ NOT APPLICABLE

NOTE:

- Air supply should be clean and free from obvious water contamination. Preferably instrument quality.
- Control unit should be connected to a suitable air supply as above using a suitable air hose.
- Recommended size is 1/2" ID. Ensure air supply valve on control panel is OFF, and air regulators are turned fully anti-clockwise before connection of air supply.

SECTION 17

LIFTING SET

LIFTING SET P/N: 990037808 (W.L. L=8.6T)

1 set 4-legged wire rope consists of:

- a) 1 pc 1-1/8" master link assembly.
- b) 4 pcs of 2.0m x18mm/19mm wire rope slings.
- c) 4 pcs of 3/4" bolt type anchor shackle.

SECTION 18

DRAWING AND BILLS OF MATERIAL

18.1 DRAWING

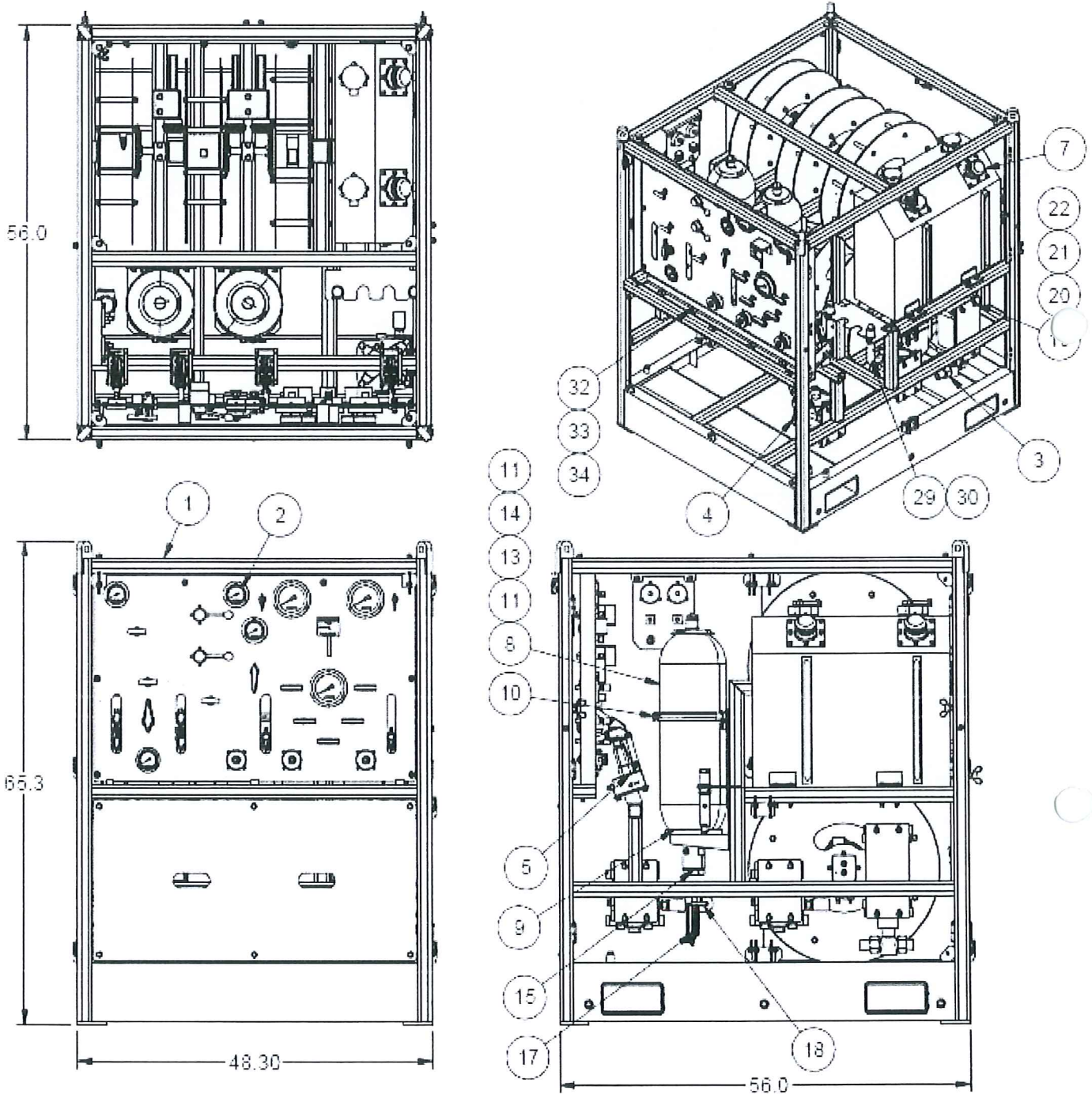

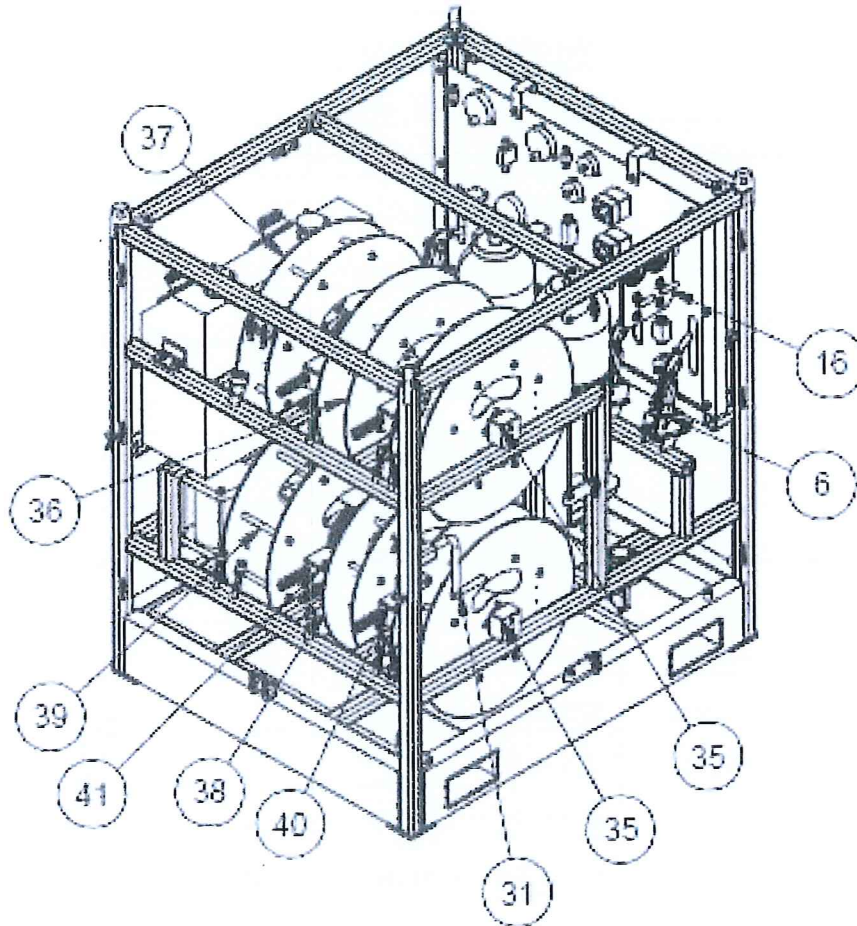

NOTE: COVER PLATES HIDDEN FOR TO VIEW EQUIPMENTS.

18.2 BILL OF MATERIALS

| ITEM | PART NUMBER | DESCRIPTION | QTY |
|------|-------------|-----------------------------|-----|
| 1 | 990063153 | WELDED FRAME ASSY | 1 |
| 2 | 990063154 | CONTROL PANEL ASSY | 1 |
| 3 | 990043509 | LIQUID AIR DRIVEN PUMP | 1 |
| 4 | 990038286 | LIQUID AIR DRIVEN PUMP | 2 |
| 5 | 990003304 | 20K HAND PUMP ASSY | 2 |
| 6 | 990039620 | 10K HAND PUMP ASSY | 2 |
| 7 | 990041410 | OIL TANK ASSY | 1 |
| 8 | 990037363 | ACCUMULATOR | 2 |
| 9 | 990019555 | RUBBER SUPPORT RING | 2 |
| 10 | 990018151 | ACCUMULATOR CLAMPS | 2 |
| 11 | 990011203 | HEX BOLT | 4 |
| 12 | 990003965 | FLAT WASHER | 8 |
| 13 | 990003966 | SPRING WASHER | 4 |
| 14 | 990003967 | HEX NUT | 4 |
| 15 | 990023341 | ADAPTER FOR STD ACCUMULATOR | 2 |
| 16 | 990056528 | NIROGEN CHARGING SETUP ASSY | 1 |
| 17 | 990004052 | AIR FILTER | 1 |
| 18 | 990037346 | AIR FILTER U BOLT | 1 |
| 19 | 990011313 | HEX BOLT | 28 |
| 20 | 990016365 | FLAT WASHER | 42 |
| 21 | 990003979 | SPRING WASHER | 14 |
| 22 | 990003978 | HEX NUT | 14 |
| 23 | 990025464 | CROWFOOT | 1 |
| 24 | 990001692 | SNAP TITE NIPPLE VALVED | 5 |
| 25 | 990001691 | SNAP TITE COUPLER VALVED | 5 |

CONTROLLED COPY

| ITEM | PART NUMBER | DESCRIPTION | QTY |
|------|-------------|--------------------------------------|-----|
| 26 | 990001611 | QUICK CONNECTION BOX END | 1 |
| 27 | 990063485 | SNAP TITE COUPLER VALVED | 2 |
| 28 | 990063486 | SNAP TITE NIPPLE VALVED | 2 |
| 29 | 990063487 | HIGH LOW-PRESSURE SENSOR ALARM VALVE | 2 |
| 30 | 990058346 | LOCK NUT F/HIGH-LOW PR. SENSOR | 2 |
| 31 | 990043174 | HANDLE FOR REWINDING MECHANISM | 1 |
| 32 | 990041466 | CLAMP FOR HAND PUMP LEVER FIXING | 4 |
| 33 | 990015235 | BHCS | 4 |
| 34 | 990032486 | LOCK NUT | 4 |
| 35 | 990057605 | RIGHT HAND TWIN HOSE REEL ASSY | 2 |
| 36 | 990041403 | RIGHT HAND SINGLE HOSE REEL ASSY | 1 |
| 37 | 990038321 | LEFT HAND SINGLE HOSE REEL ASSY | 1 |
| 38 | 990018012 | RIGHT HAND HOSE REEL ASSY | 1 |
| 39 | 990063628 | LEFT HAND TWIN HOSE REEL ASSY | 1 |
| 40 | 990043087 | RHS REWIND MECHANISM ASSY | 2 |
| 41 | 990043086 | DOUBLE REWIND MECHANISM ASSY | 2 |
| 42 | 990004940 | 1/2" ID x 60FTAIR HOSE | 1 |
| 43 | 990039766 | 1/4" ID x 150FT SB HOSE | 1 |
| 44 | 990056612 | 3/8" ID x 75FT BOP HOSE | 4 |
| 45 | 990063683 | 1/4" ID x 100FT TEST LINE HOSE | 1 |
| 46 | 990063687 | 1/4" ID x 150FT SV/MV HOSE | 2 |
| 47 | 990037808 | LIFTING SLING SET ASSY (W.L.L=8.6T) | 1 |
| 48 | 990042217 | NAME PLATE | 1 |

CONTROLLED COPY

RMZ – WIRELINE 15K PRESSURE CONTROL TRAINING SCHOOL

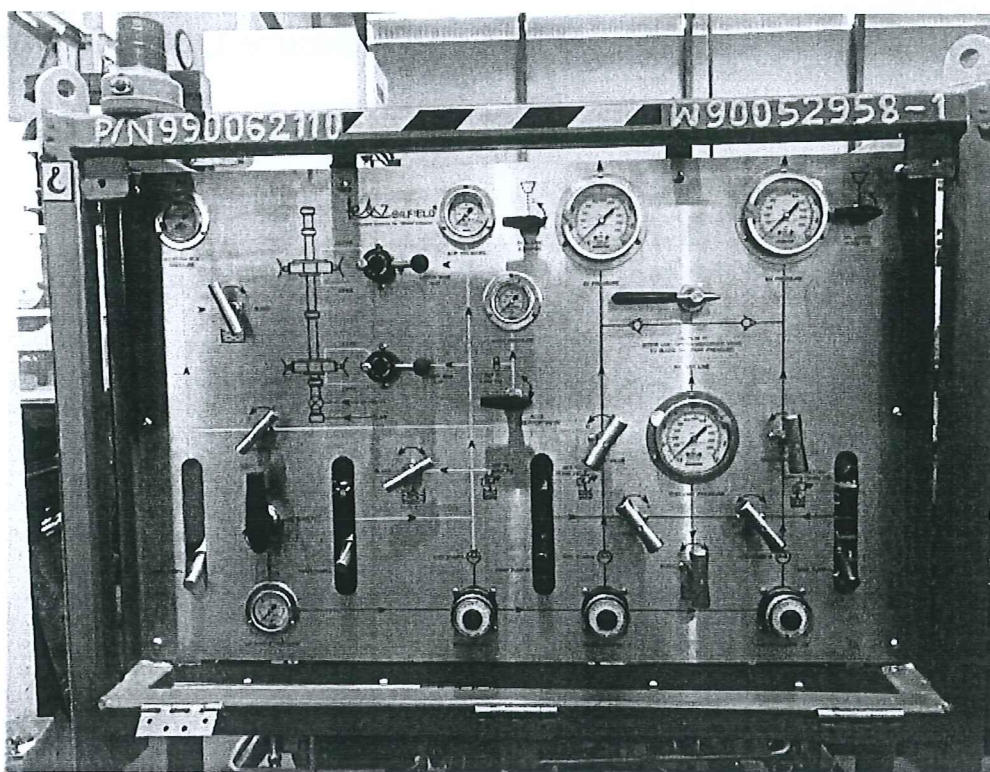

- Pressure gauge
 - Selector valve

Front View :- Full Face 15K Pressure Control Panel

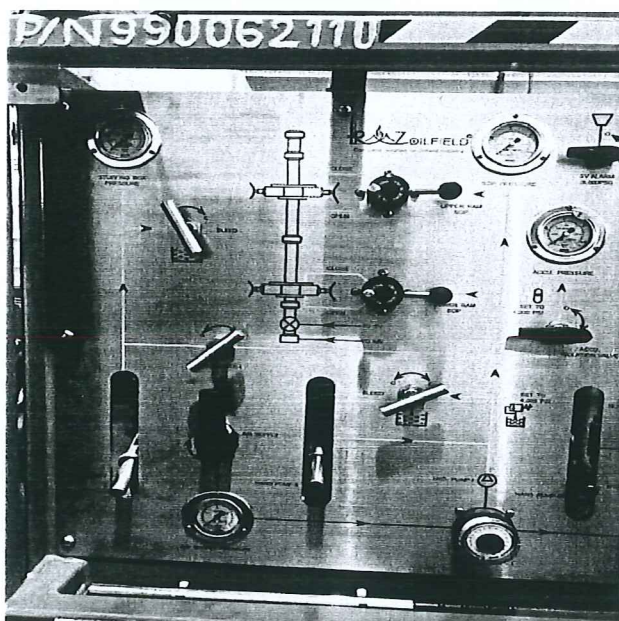

Side A :- Wellhead BOP Control

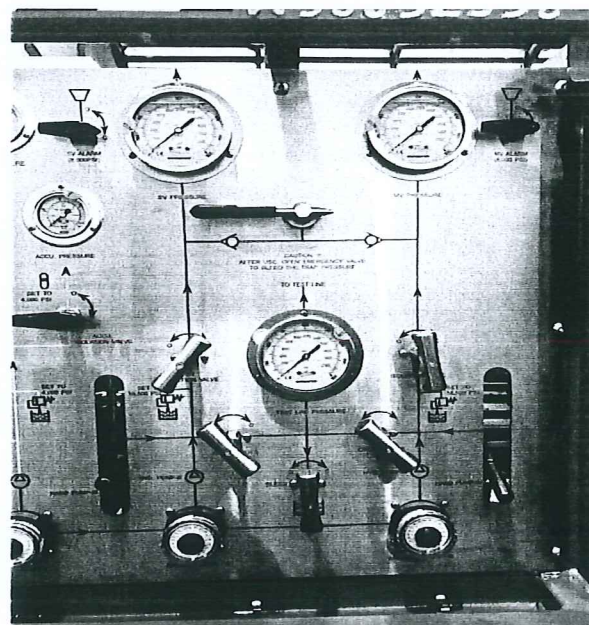

Side B :- Wellhead Downhole Control

MV/SCSSV / BV / Test line.

RMZ – WIRELINE 15K PRESSURE CONTROL TRAINING SCHOOL

RMZ – WL PCE HP Hydraulic Hoses and Pressure Lines Assembly



Side View

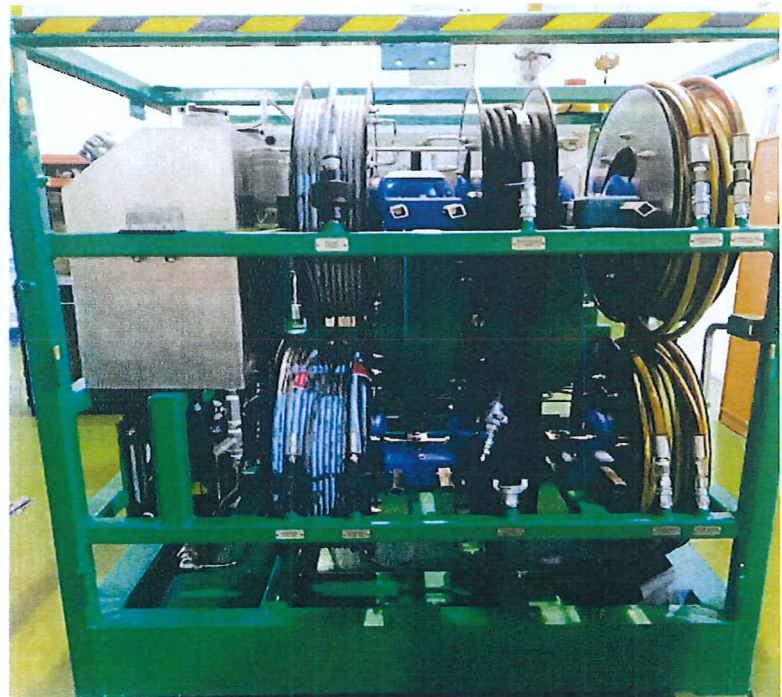

Front View

Commercial Confidential - Copyright RMZ Oilfield Engineering Pte Ltd

Reg.No: 200912491E - email: sales@rmzoilfield.com - WEB: www.rmzoilfield.com



9. Control Panel

What is Control Panel

CP have series of pump and gauges that use to control our equipment and the well head.

What is the purpose of Control Panel

- To control BOP, Shutting Box, Master Valve

How to operate Control Panel

Connect the control line to the equipment. Open the air supply. Use the regulator to control pump and pressurized the line.

What is maintenance required for Control Panel

- Hydraulic oil
- Check for leak
- Bleed water / Separator.

What is safety precaution required for Control Panel

- Ensure all connection is secured
- Pressurised CP within the limit
- Ensure no leak

What is potential hazard during handling Control Panel

- Struck by equipment during lifting
- Hose burst



Draw & name each part of Control Panel

A large, empty rectangular box with a thin black border, intended for drawing and labeling the parts of a control panel. There are some faint blue scribbles at the bottom left corner of the box.

RMZ – WIRELINE 15K PRESSURE CONTROL TRAINING SCHOOL

RMZ – WL Well Head Control Unit Assembly (Side View)

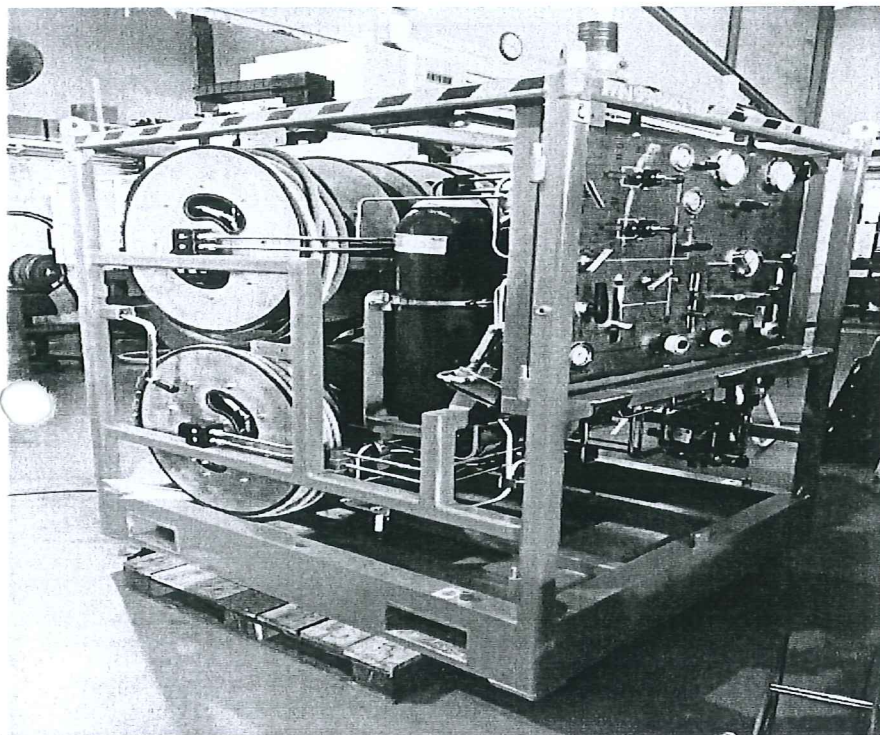

15K HP CONTROL PANEL

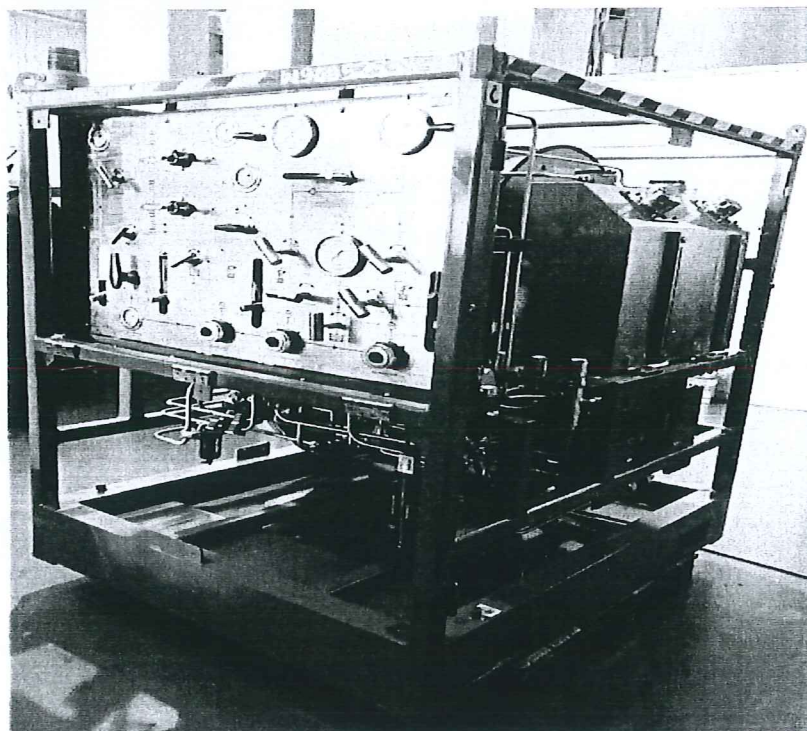

FLUID STORAGE TANKS AND SAFETY REGULATORS

Commercial Confidential - Copyright RMZ Oilfield Engineering Pte Ltd

Reg.No: 200912491E - email: sales@rmzoilfield.com - WEB: www.rmzoilfield.com

RMZ – WIRELINE 15K PRESSURE CONTROL TRAINING SCHOOL

RMZ – WL Well Head Control Unit Assembly (Front View)

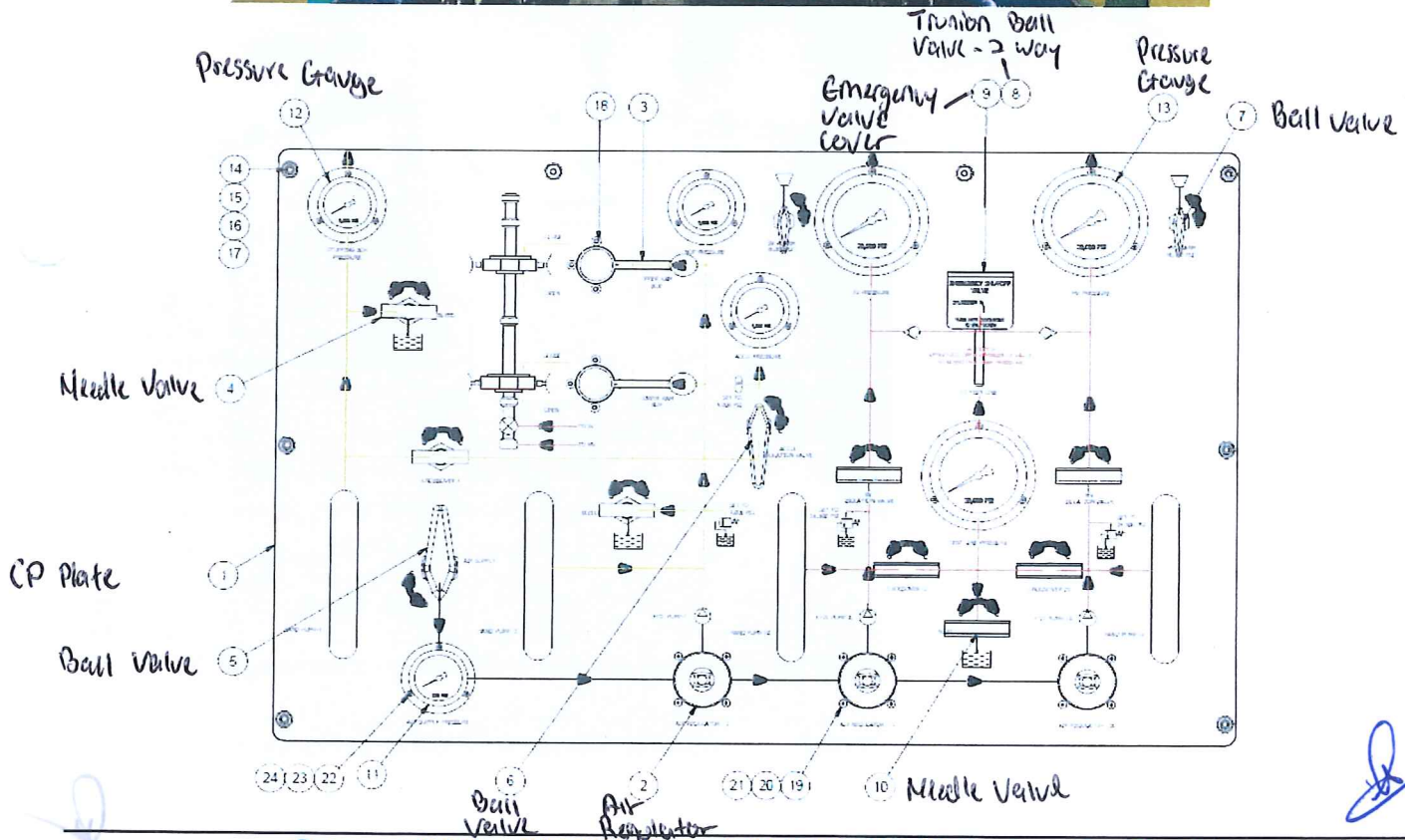
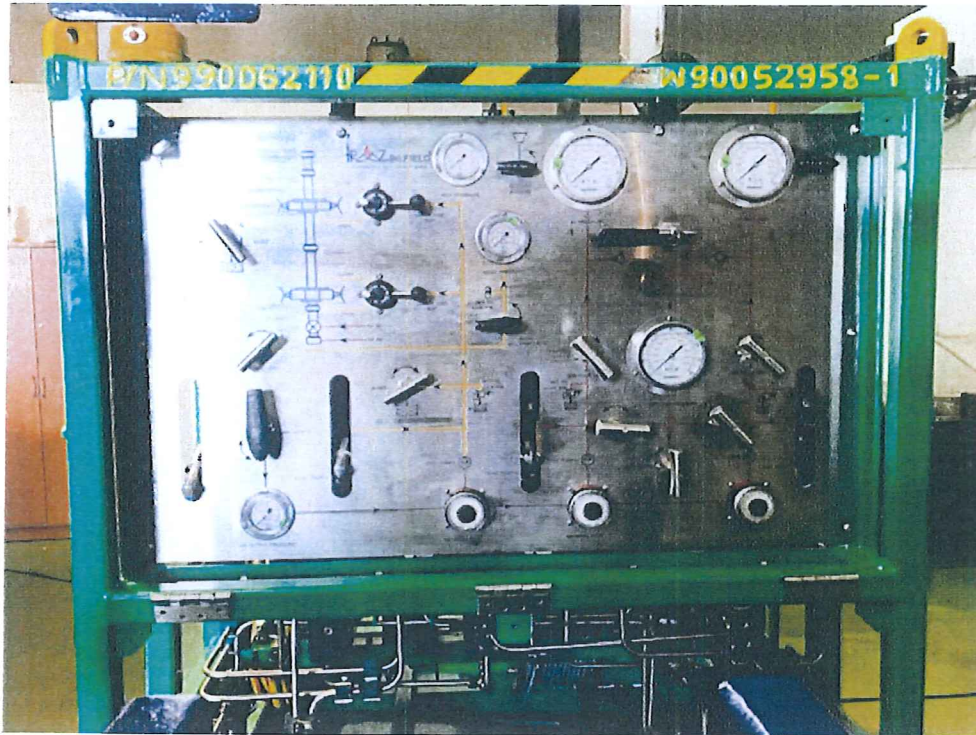

Commercial Confidential - Copyright RMZ Oilfield Engineering Pte Ltd

Reg.No: 200912491E - email: sales@rmzoilfield.com - WEB: www.rmzoilfield.com



10. Huskel Drum

What is Huskel Drum

Huskel pump is a recognized leader in high pressure technology, Manufacturing high pressure air driven liquid pump.

What is the purpose of Huskel Drum

~~to cut~~ - Can shell and hold ~~pressure~~ ^{virtually} pressure with no flow or internal leakage.
- Pump non lubricating fluids such as water or solvents to very high pressure.

How to operate Huskel Drum

- Pneumatic

What is maintenance required for Huskel Drum

- O-ring

What is safety precaution required for Huskel Drum

- Ensure tubing connection in good condition
- Ensure O-ring in good condition

What is potential hazard during handling Huskel Drum

- Pinch point
- Tubing burst



Draw & name each part of Huskel Drum

A large, empty rectangular box with a thin black border, intended for the student to draw and label the parts of a Huskel Drum.

Power Pack

- Diesel driven.
- Certified with Zone 2.
- Approved to carry out on Drilling Rig and Production Platform
- Maintenance .
- Purpose.
- To provide and Supply the Hydraulic power to RSU.

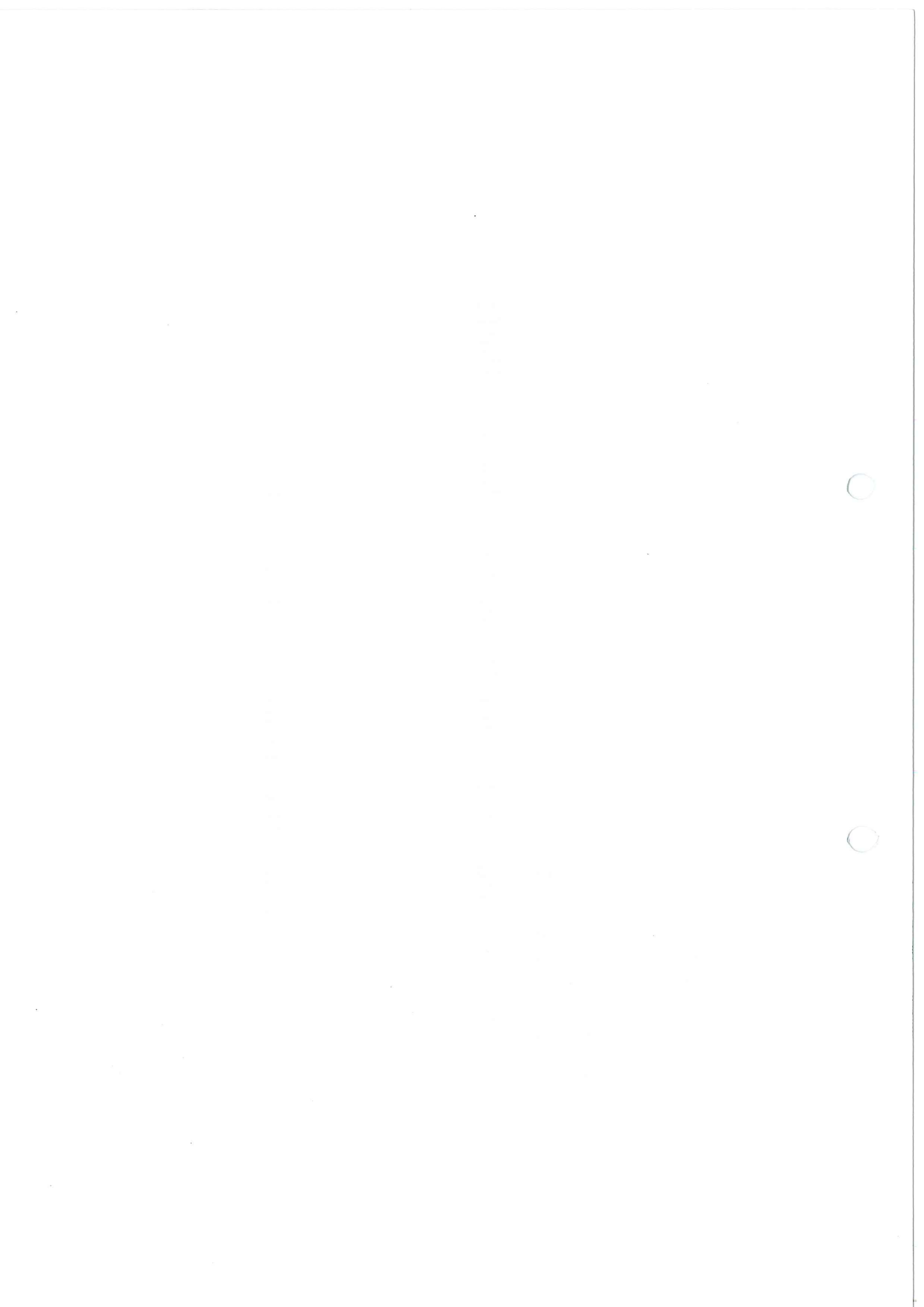



11. Power Pack (Electrical & Diesel)

What is Power Pack

PP is a machine that consist of electric motor or diesel engine that use to drive hydraulic pump for RSU operation or Mast.

What is the purpose of Power Pack

- Supply hydraulic power

How to operate Power Pack

- Pneumatic (AC / manually)
- Spring Steer
- Hydraulic.

What is maintenance required for Power Pack

- Change engine oil
- Change filter
- Bleed water from diesel tank
- Check oil gauge
- Check for leaks
- Radiator clean and flush

What is safety precaution required for Power Pack

- Ensure GSD functioning
- PRV working well
- Over Speed Shutdown, cut off around 2100 rpm

What is potential hazard during handling Power Pack

- Pinch by cover
- Hose burst
- Rotating fan.



Draw & name each part of Power Pack

Power Pack

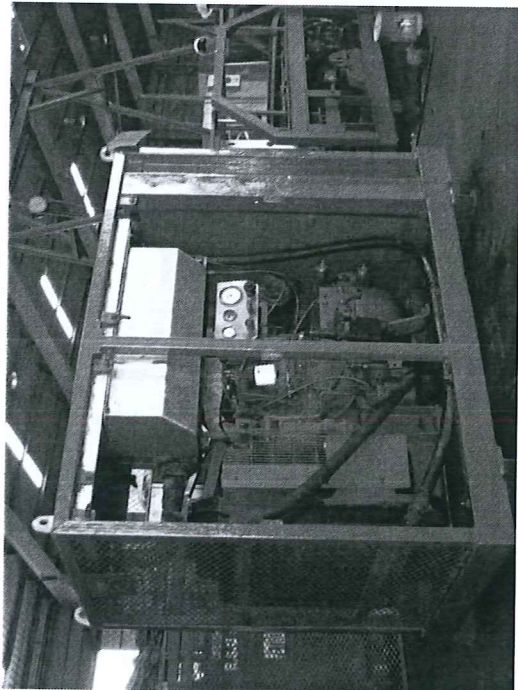
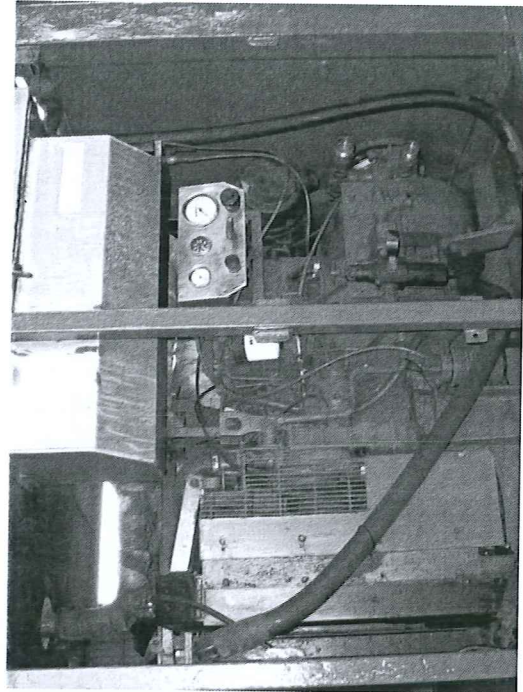



12. Air Compressor

What is Air Compressor

A machine that have a compressor driven by diesel engine

What is the purpose of Air Compressor

Supply air to control panel, test pump, air starter engine

How to operate Air Compressor

The starting procedure is almost the same with power pack. The air compressor usually use the spring starter. To crank the starter, rotate the shaft clockwise until indicator turn red. Release the spring to start the engine.

What is maintenance required for Air Compressor

- Check auto bleed valve
- Bleed water from diesel tank
- Check fan belt tension
- Change compressor oil
- Change filter

What is safety precaution required for Air Compressor

- Ensure safety valve is working.
- Ensure engine overspeed functioning.

What is potential hazard during handling Air Compressor

- Hose burst
- Pinch point
- Rotating equipment
- Hot Surface.



Draw & name each part of Air Compressor



13. Drum

What is the purpose of Drum

To store wire

Do the right and wrong wire arrangement from drum to hay pulley

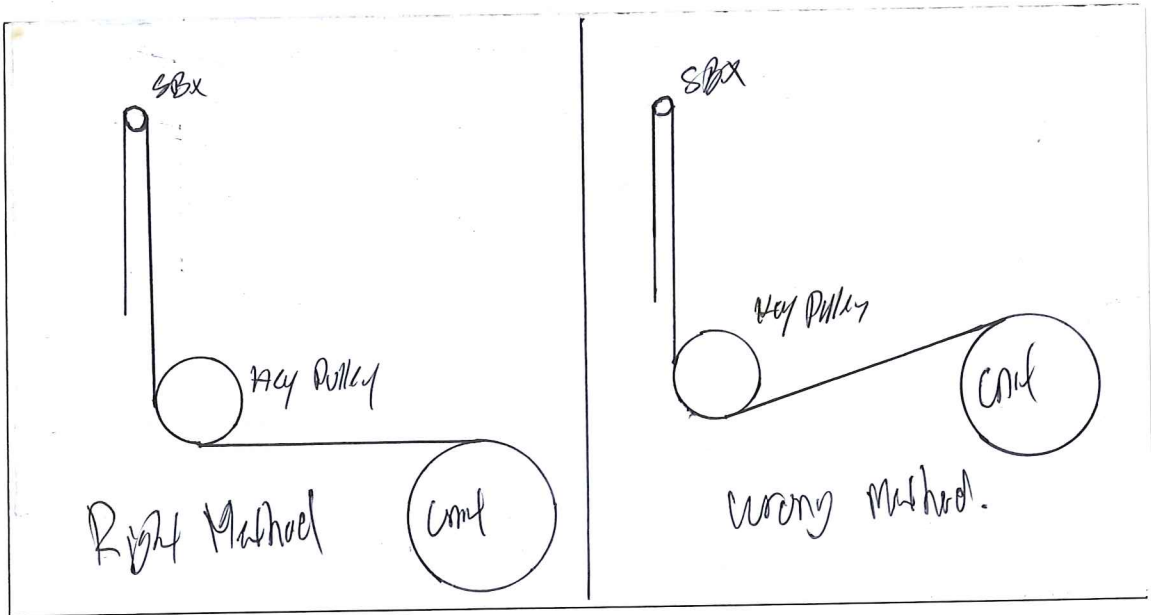

What is maintenance required for Drum

- Grease pillow bearing.
- Polish the drum

What is safety precaution required for Drum

- Ensure pillow bearing is fitted properly

What is potential hazard during handling Drum

- wire break
- Bolt parted due to excessive drum wobbling.



Please draw/sketch the toolstring configuration for:

- 1) Drift run/tubing clearance check
- 2) Sinker bar run
- 3) Set and retrieve plug
- 4) Set and retrieve insert valve

Toolstring



ROPE SOCKETS

The Rope Socket is required to make the connection between the wireline and toolstring.

Types in most common use:

- 0.092" regular knot type.
- 0.092" / 0.108" / 0.125" no-knot type (teardrop).
- 1/16" braided.

0.092" Regular Knot Type

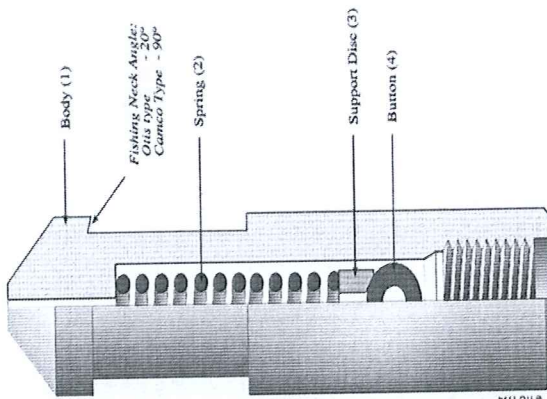

871C 194

871C 194B. Subject to the Copyright Act 1968. No part of this publication may be reproduced or stored in a retrieval system without the prior written permission from H2C.



TOOLSTRING COMPONENTS

The basic toolstring components are shown here.

The diameters in most common use are 1 1/2", 1 3/4", and 2 1/2", but toolstring components are also available in 1", 1 1/4", 2 1/8", and 2 3/8" diameters.

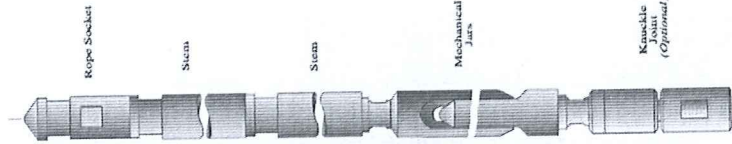

Rope Socket
Provides a link with the wireline.

Swivel Joint
Attached between the rope socket and stem if required.

Stem
To add weight / mass to the toolstring to overcome well pressure and friction, and provide impact downhole.

Upsroke Jars
Attached here if required.

Mechanical Jars
To provide a means of generating impact.

Knuckle Joint (Optional)
Attached here if required.

Attach the required tool to the bottom of the jars or knuckle.

871C 194B. Subject to the Copyright Act 1968. No part of this publication may be reproduced or stored in a retrieval system without the prior written permission from H2C.



Handwritten mark or signature in blue ink at the bottom left corner.

What is Rope Socket

- Slickline Rope Socket is designed to attach the wire to the toolstring. The slickline Rope Socket incorporates robust feature which is designed to maintain form and ensure continuous performance.



The Purposed of Toolstring.

Purpose.

- Rope socket is connected to Toolstring. It designed to hold the toolstring running / pulling into the well.
- The swivel joint is for toolstring more flexibility to toolstring rotating while pulling / running in hole.
- Stem is to provide the weight of the toolstring and giving a weight impact while jarring down / up.
- Link jar is to provide a generating impact while jarring up and down.
- Knuckle join to generating the tool bending while run in hole or at tubing accessories.
- Hydraulic Jar to provide a generating impact while jarring up ward. Especially to retrieve a stuck tool or fishing operation.

Toolstring Maintenance

- Check the Body condition.
- Check the Fishing neck OD.
- Check the Thread condition.
- Rope socket check the components replace if required.
- Hydraulic jar check all the O-ring, Grab screw, Tapelon seal

Intervention and Completion Tools

Service Tools

Special Application Tools

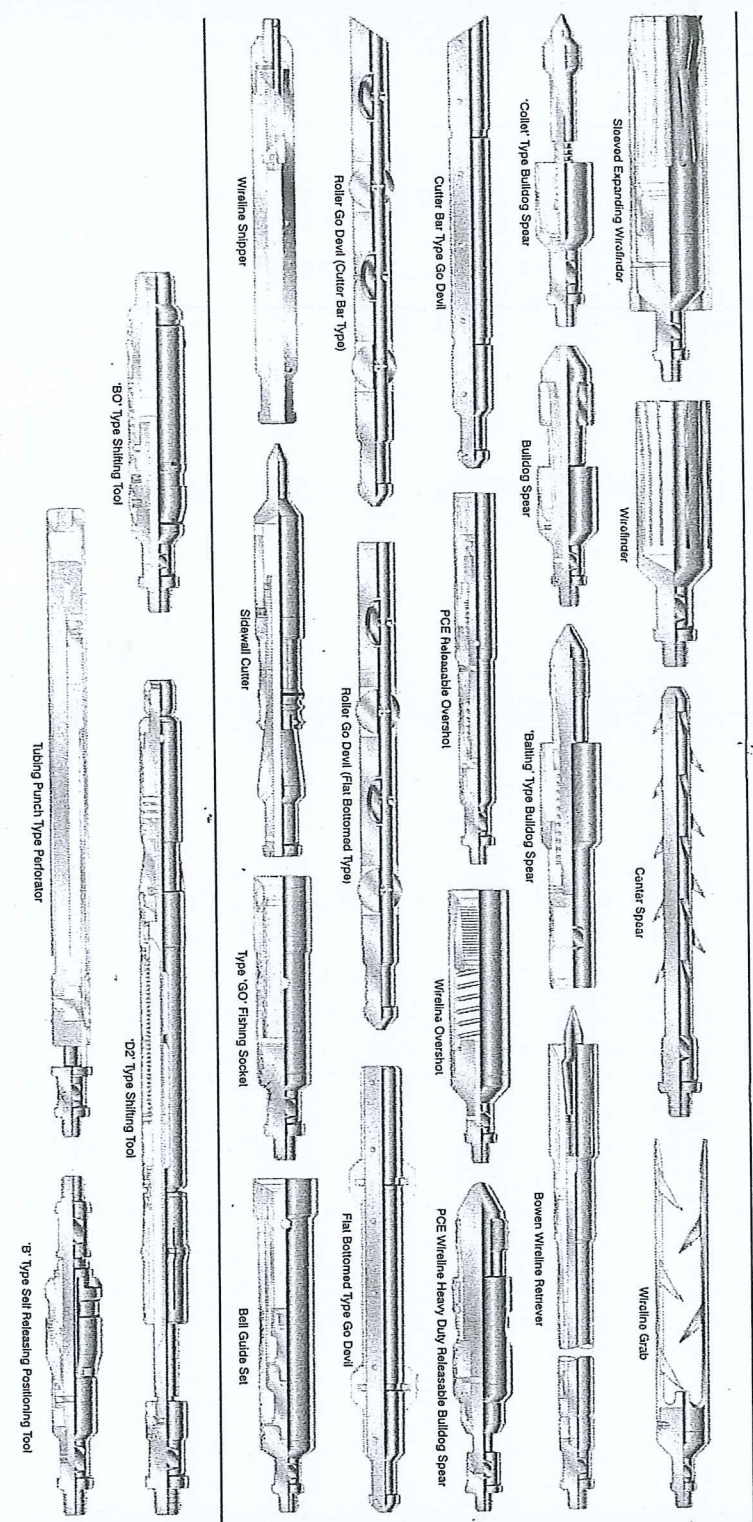
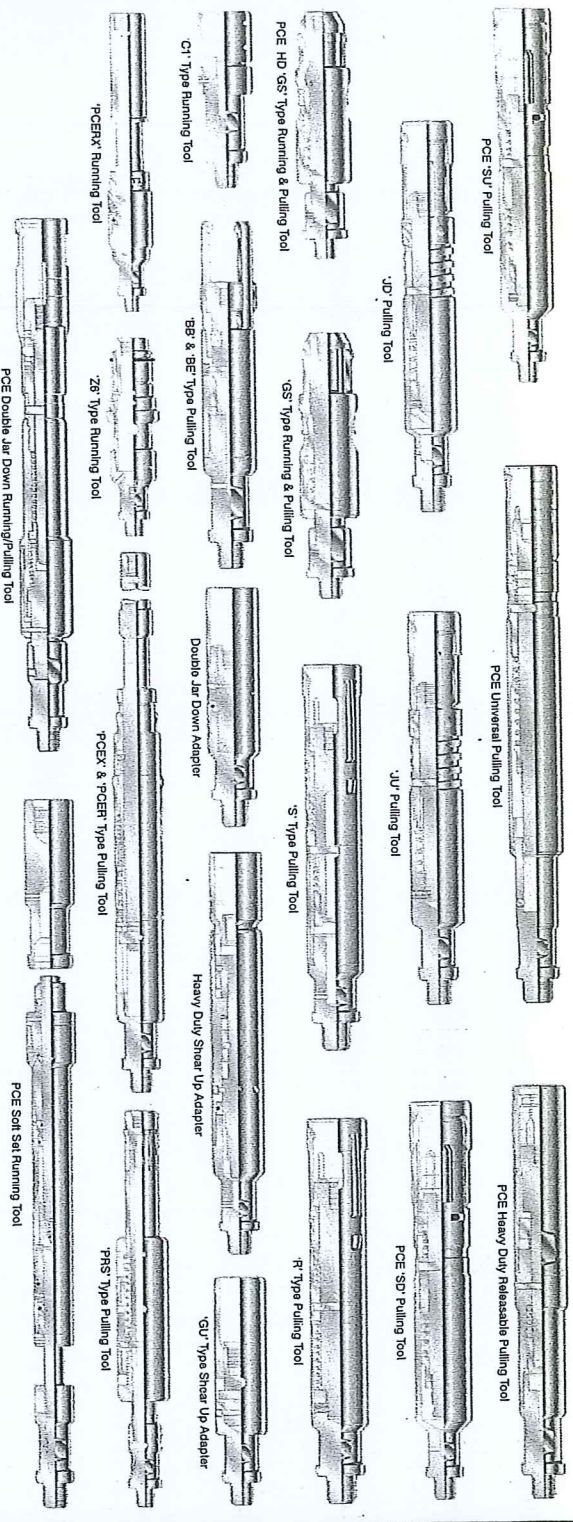

We Service and Completion Solutions



Wireline/Slickline Tool Range

Wireline/Slickline Toolstring Components

Rope Sockets, Stem, Release Joints, Jars, Intensifiers, Combination Toolstrings, Shock Absorbers, Joints, Connectors

Swages, Gauge Cutters, Centralizers, Tubing End Locators, Bailers

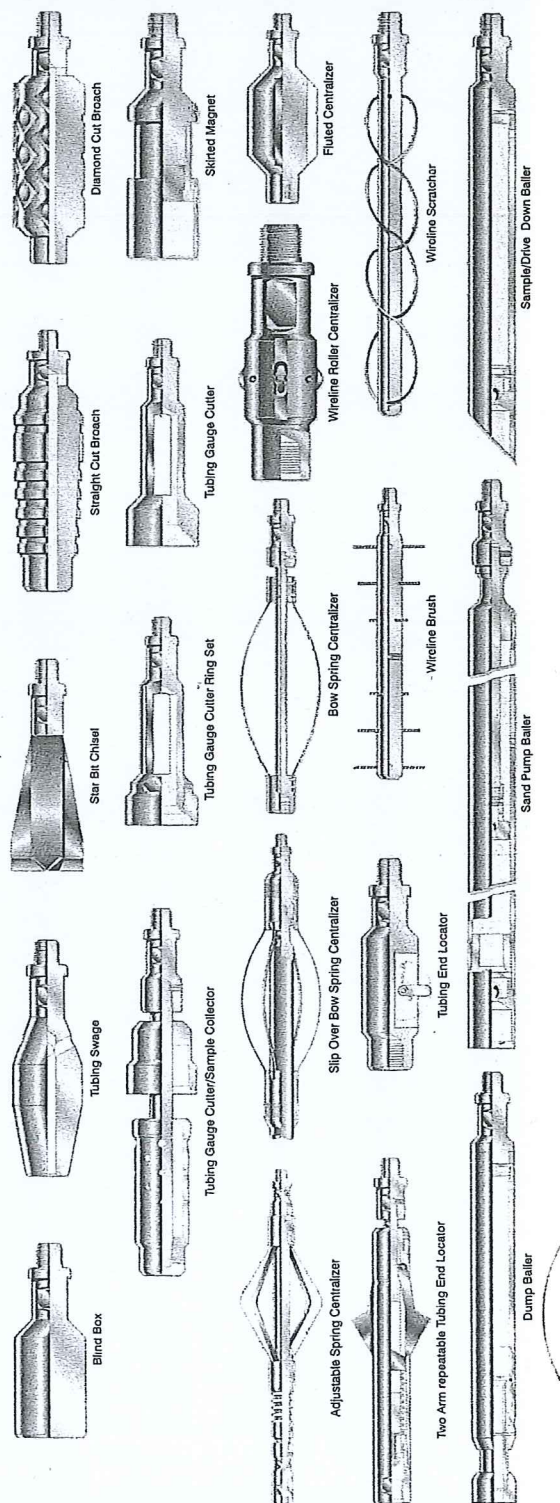
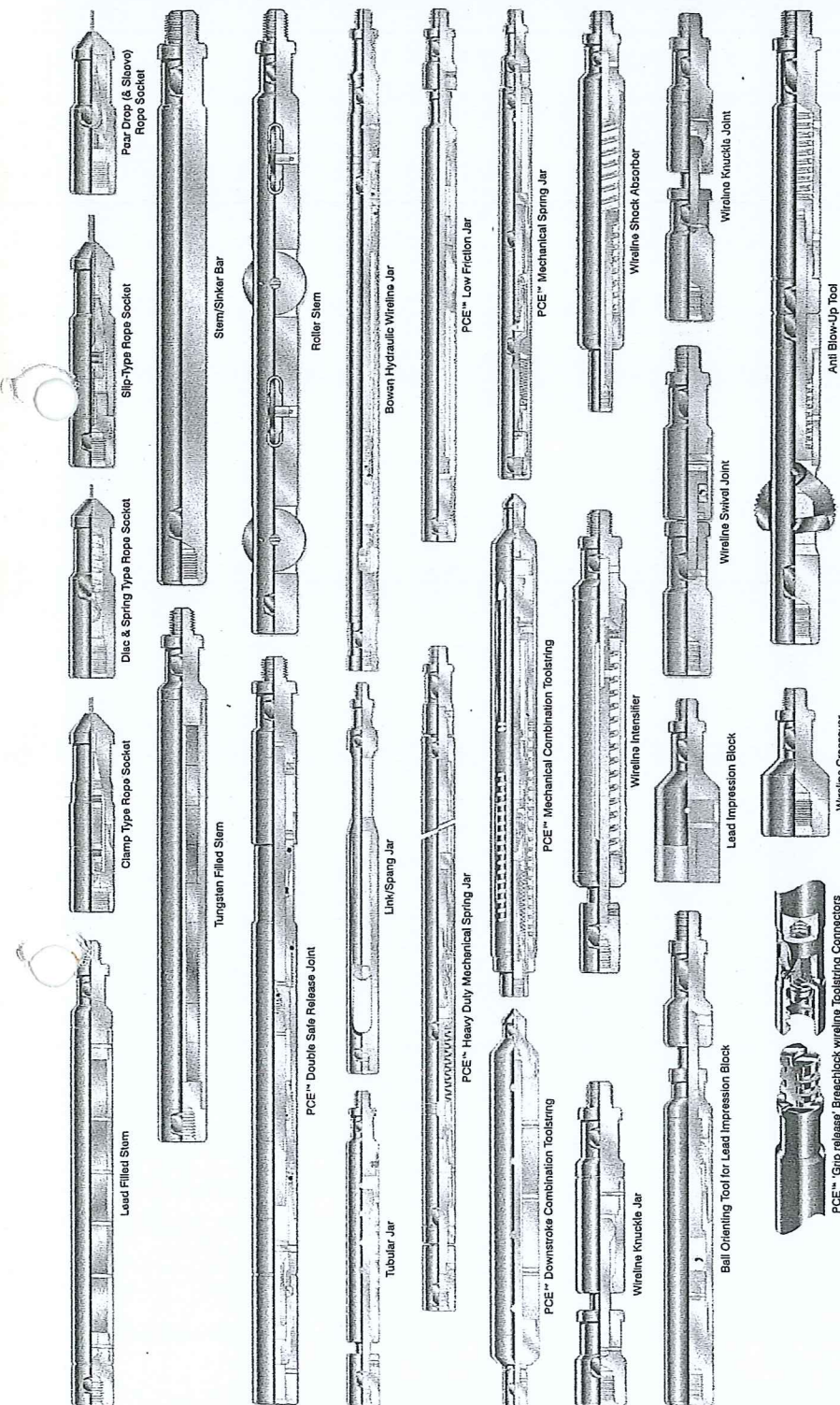

www.nov.com/ASEPElmar

80% ASEPElmar Worldwide Contacts

ASEPElmar-UK@nov.com
Tel: +44 1224 740261

ASEPElmar-Singapore@nov.com
Tel: +65 6346 0928

ASEPElmar-NL@nov.com
Tel: +31 84 608 700

ASEPElmar-Americas@nov.com
Tel: +1 713 933 9281

ASEPElmar-Dubai@nov.com
Tel: +971 4 883 5910

SLICKLINE TOOLCHART : GASLIFT TOOLS

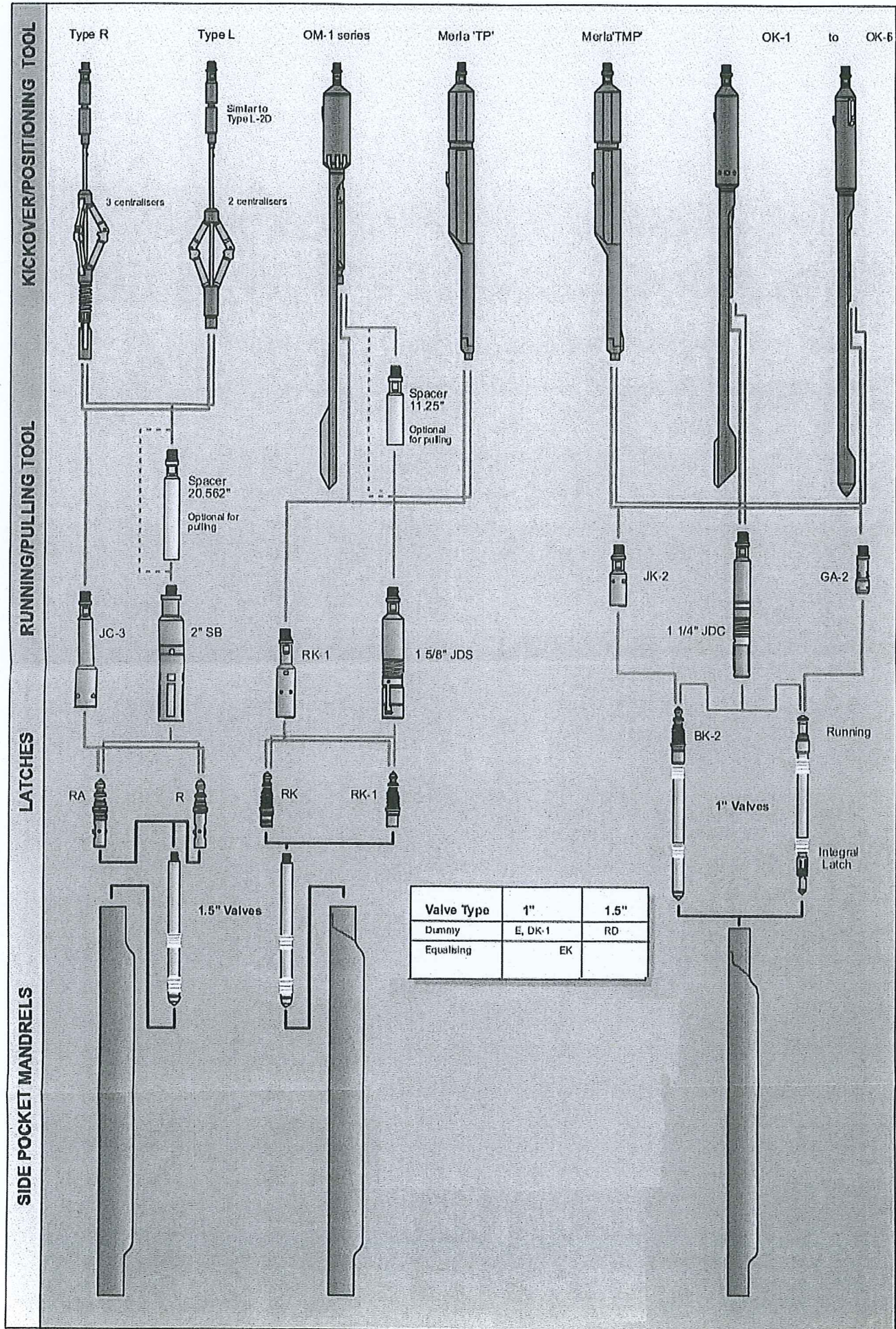



SLICKLINE TOOLCHART : PULLING/RUNNING TOOL

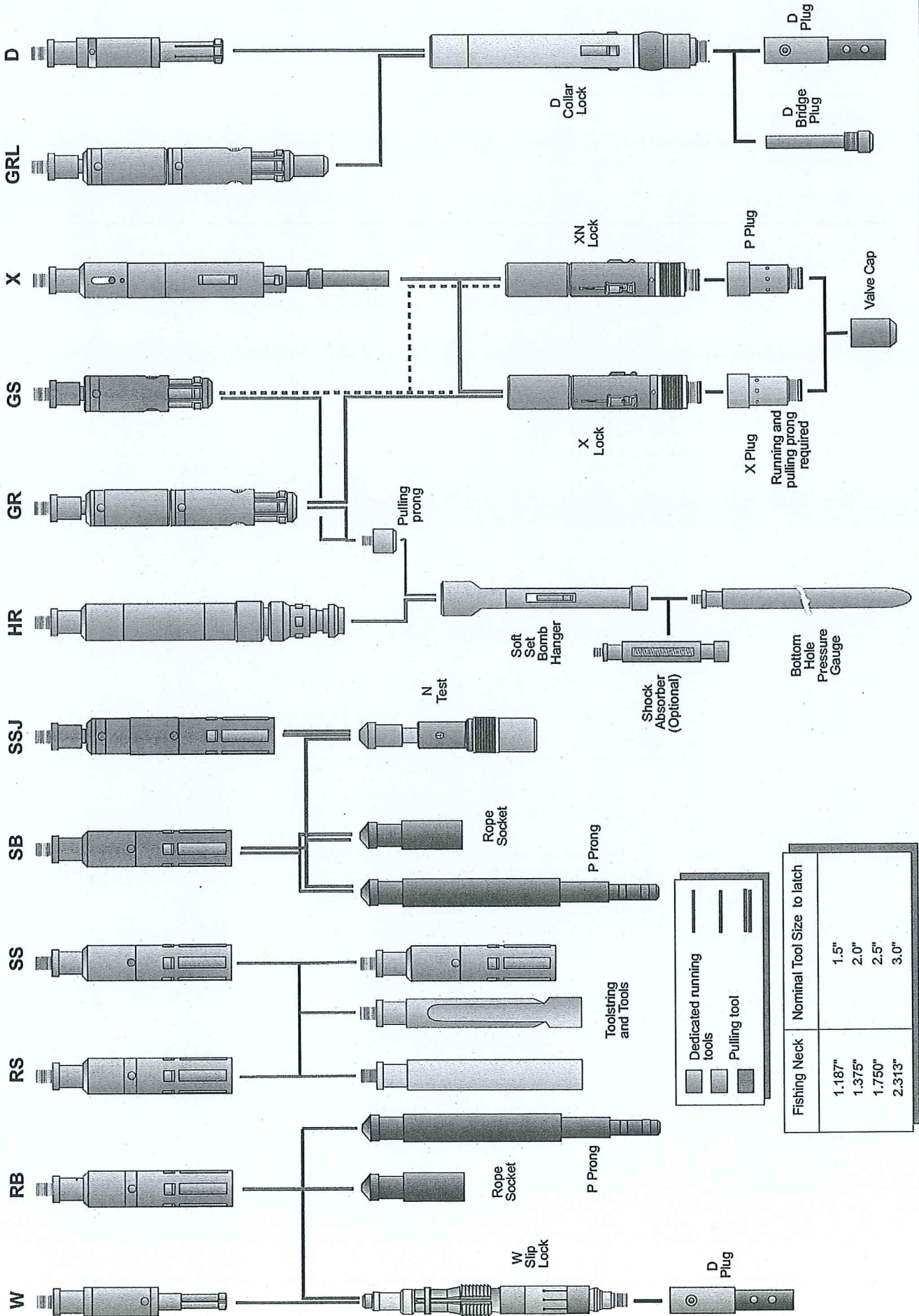

Toolstring and Tools

- Dedicated running tools
- Pulling tool

| Fishing Neck | Normal Tool Size to latch |
|--------------|---------------------------|
| 1.187" | 1.5" |
| 1.375" | 2.0" |
| 1.750" | 2.5" |
| 2.313" | 3.0" |

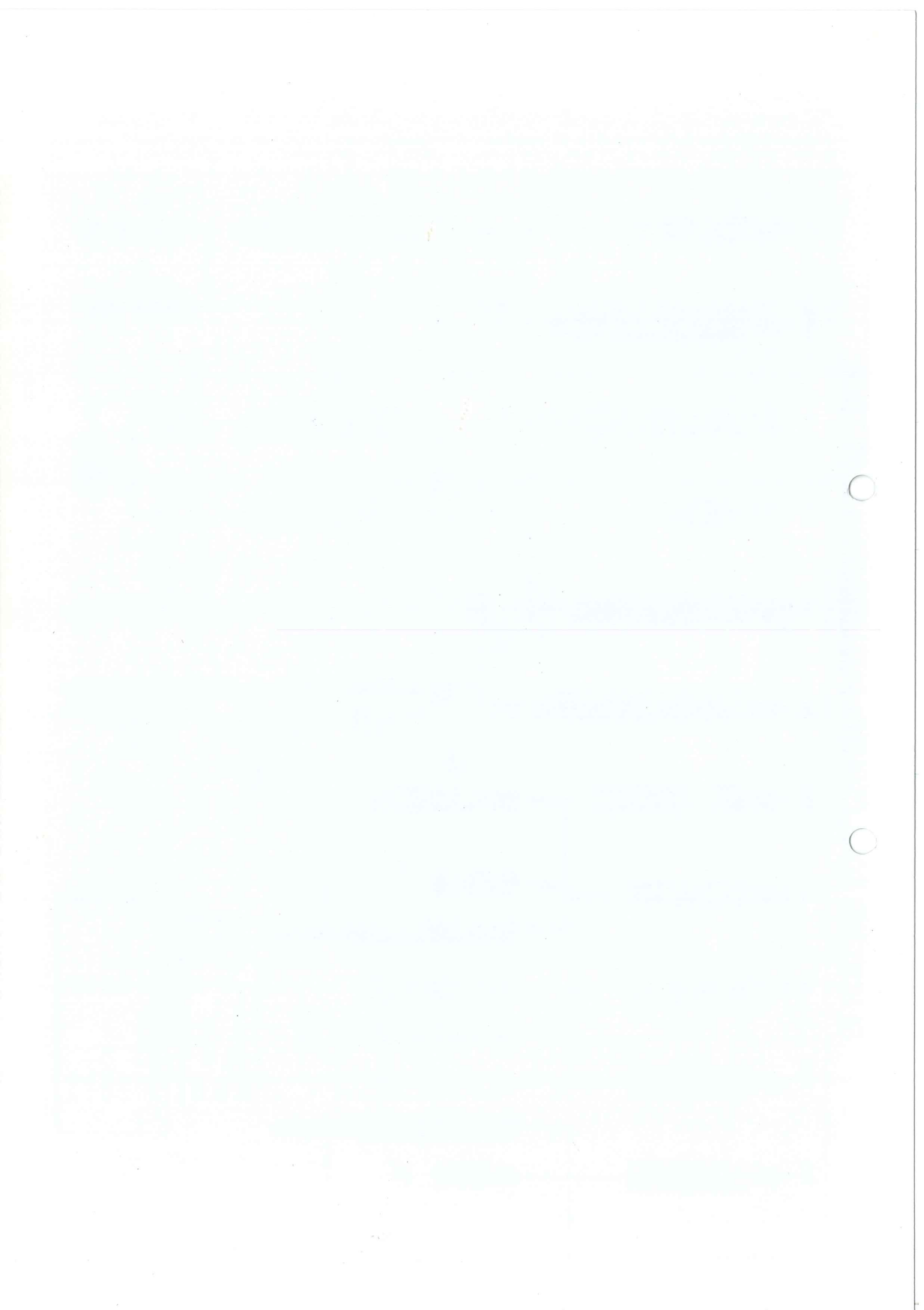



SLICKLINE TOOLCHART : CAMCO TOOLS

