

# SLICKLINE ASSISTANT WORKBOOK

**IMPORTANT NOTE:**

1. Your point of reference to complete this workbook may be obtained from the following
  - Training Manual and any other training materials provided together with this workbook
  - Your Trainer, Assessor (Slickline Operator), Verifier (FSM) or senior colleagues
  - SOP / Quality Procedures & Processors
2. The completion of this Workbook is a joint effort and responsibility between you and your assessor therefore you have the obligation to request from your assessor to be assessed upon your completion of each topic
3. The completion of this Workbook is part of the MANDATORY requirements which you must fulfill to qualify for a promotion
4. Your training program is mostly self-driven, including this Workbook. It requires individual initiatives, dedication and commitment to complete the process.

NAME	LARRY DAVID GAU
DATE OF JOIN	24/06/2024
CONTACT NO.	014-5442993
RECEIVED DATE	02/09/2025
DATE COMPLETED	20/03/2025

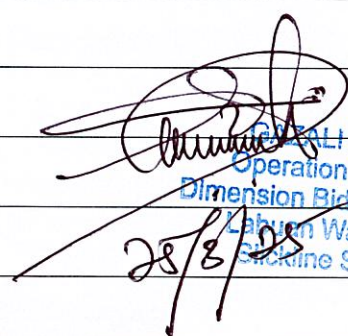

ALI MEHRY  
 Operation Manager  
 Dimension Bid (M) Sdn Bhd  
 Labuan Warehouse  
 Slickline Services

28/8/25

### C. DOWNHOLE EQUIPMENT

1. List out all basic running and pulling tools

No.	Items
1	GS (pulling tool) ✓
2	GR (pulling tool) ✓
3	GSL (pulling tool) ✓
4	GU (pulling tool) ✓
5	JDC (pulling tool) ✓
6	JDS (pulling tool) ✓
7	JUS (pulling tool) ✓
8	JUC (pulling tool) ✓
9	JUL (pulling tool) ✓
10	RS (pulling tool) ✓
11	RB (pulling tool) ✓
12	RJ (pulling tool) ✓
13	SB (pulling tool) ✓
14	SS (pulling tool) ✓
15	SSJ (pulling tool) ✓
16	PCE HD (pulling tool) ✓
17	X-LINE (running tool) ✓
18	QXD (running tool) ✓
19	QXT (running tool) ✓
20	JK (running tool) ✓

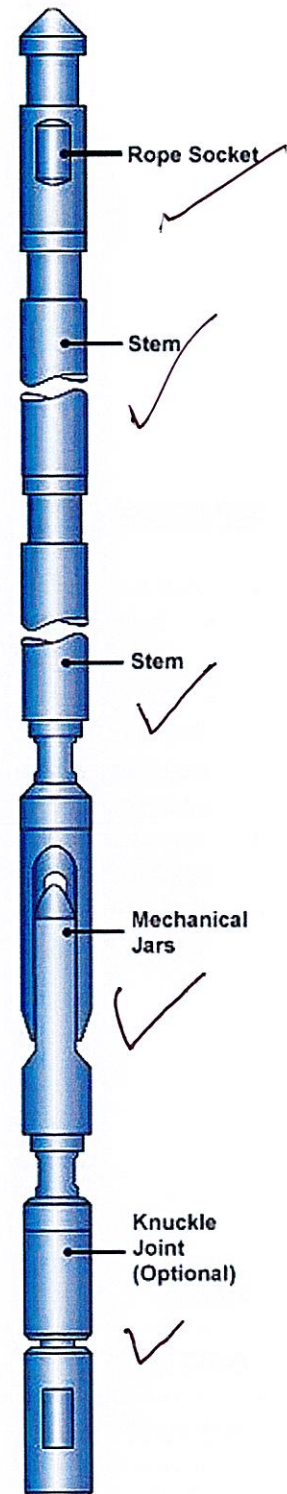

GAZALI MENTRI  
 Operation Manager  
 Dimension Bid (M) Sdn Bhd  
 Labuan Warehouse  
 Slingline Services  
 25/2/25

**Primary Wireline Tool-string**

Tool-string configuration according to requirement. Introduction to

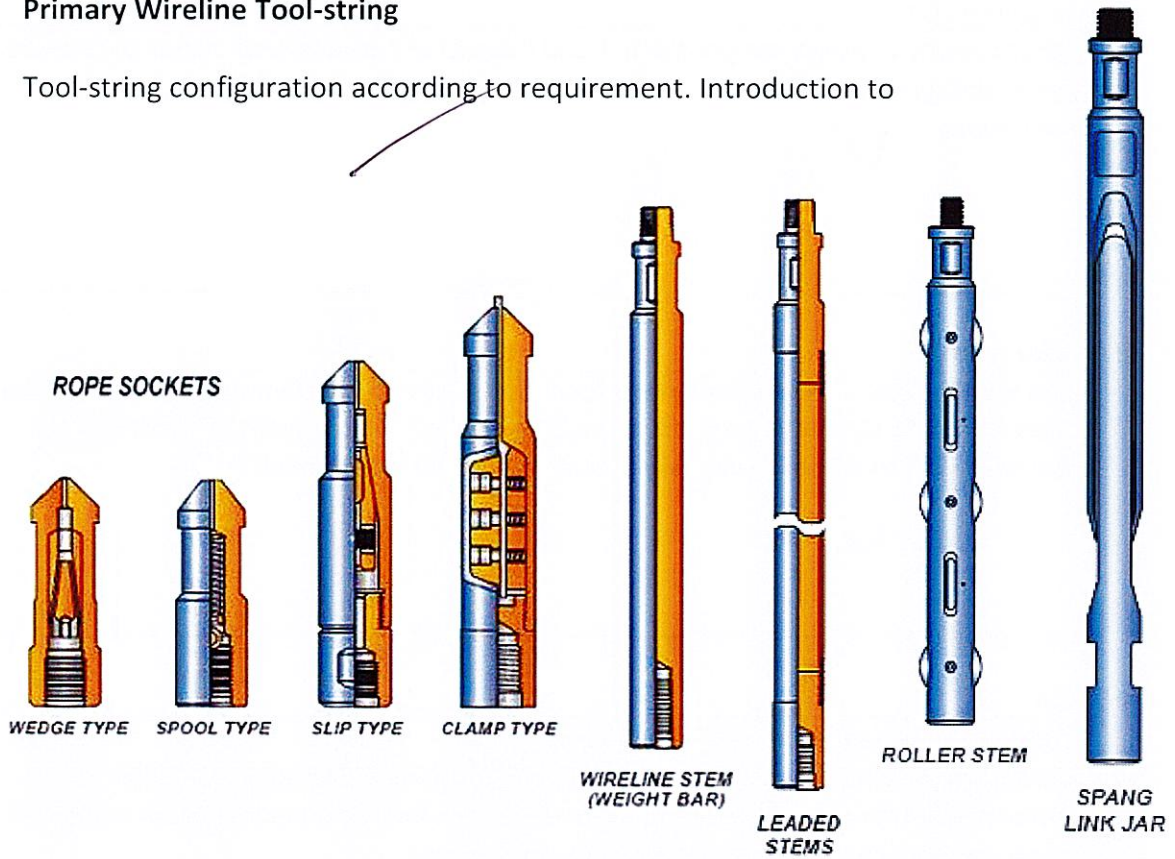

a) rope sockets

The uppermost component in the slickline toolstring and forms an essential link between the toolstring and the wire.



b) stem lead

Lead-filled stem (No heavy jarring action). Provide greater mass required in wireline operations.



*[Handwritten signature]*  
25/3/25

GAZALI MEHRY  
Operation Manager  
Dimension Bid (M) Sdn Bhd  
Labuan Warehouse  
Slickline Services



c) tungsten stem

Higher density of heavy weight stem. Used instead of conventional stems to provide kinetic energy to assist upward and downward jarring impact in higher pressure applications ✓

d) roller stem

Stem has the same 'weight' and 'mass' function as the regular stem but is designed with rollers to reduce the friction against the tubing wall in deviated wells. Tool consists of stem with slots to accommodate simple rollers held in position with pins. ✓

e) jars

To deliver effective jarring down or up impacts.

Also known as Stroke jar / Spang jar / Link jar and it has no removable parts.

Composed of two pieces linked together which are free to be extended or collapsed.

Below are two lengths of jar stroke in closed position:

- For 20 inches jar is known as "20 stroke". ✓
- For 30 inches jar is known as "30 stroke". ✓

  
25/3/22

Operation Manager  
Dimension Bid  
Labrador House  
Slickline Services

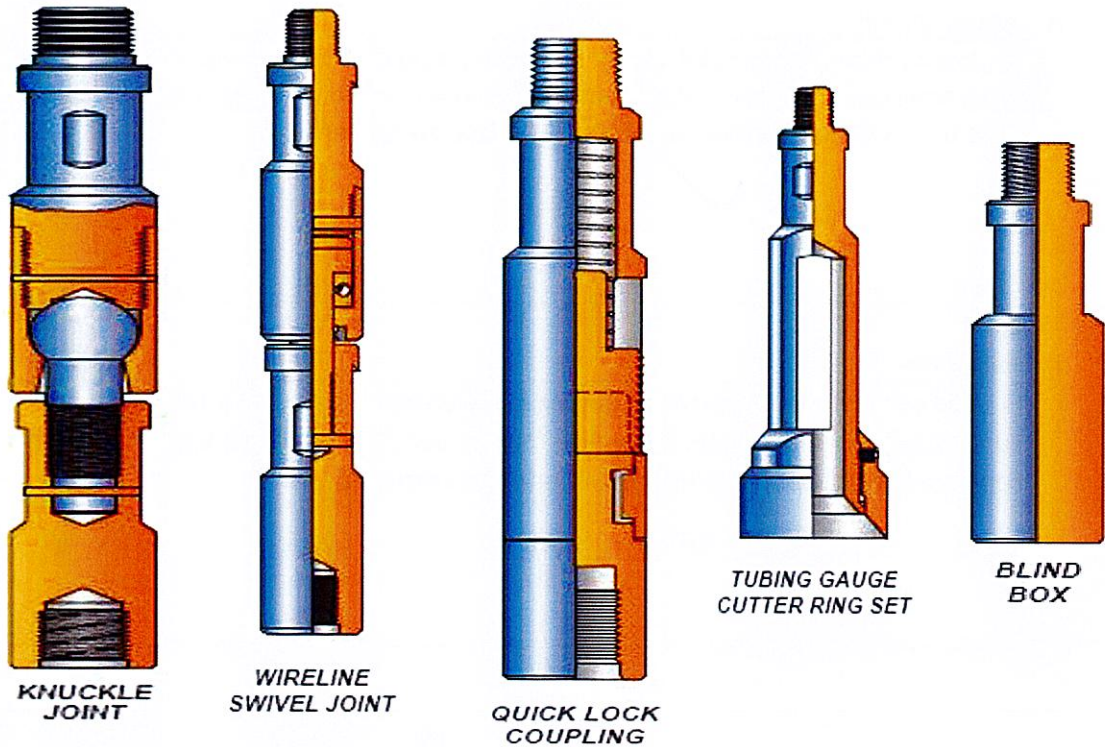

f) knuckle joints

To add flexibility to the toolstring and used in deviated well. Consists of two bodies which are connected to each other by ball and stem, and external fishing neck at the top sub. It is usually positioned immediately below the mechanical jars. Knuckle joints permit 15degree of sideways movement and should be used only when necessary. ✓

g) swivel joints

To minimize the effect of twisting wire caused by downhole tools being run. It is also to reduce the toolstring charge-out time at surface during a series of runs in the well. Essential to use a swivel between rope socket and stem to prevent twisting of line in following toolstring. The swivel joint has a bearing incorporated into its design and its used to minimize rotation whilst running in tubing. ✓

h) quick-lock coupling

Quick-lock coupling is to connect two wireline components without the use of wrenches. It allows rapid make-up and break out of toolstrings and eliminates the need for use of pipe wrenches. Available types: QLS, HD-Quick Release Joint (QRJ) and Trinity. ✓

GAZALIMERRY  
Operation Manager  
Dimension Bid Pte Ltd  
Labuan Warehouse  
Sickline Services  
25/3/19



i) gauge cutter

To check tubing ID, tag total depth, locate the nipple ID and No-Go, cut sand/scale/paraffin from tubing wall. Also known as Tubing Gauge/ Gauge ring. Can be used to run in hole before running sub-surface equipment.



j) Blind Box

Is used when heavy downward jarring is required to dislodge a fish, or push something down the hole. It is act as 'cutter bar', breaking the wireline at top of the rope socket of the toolstring that cannot be retrieved.

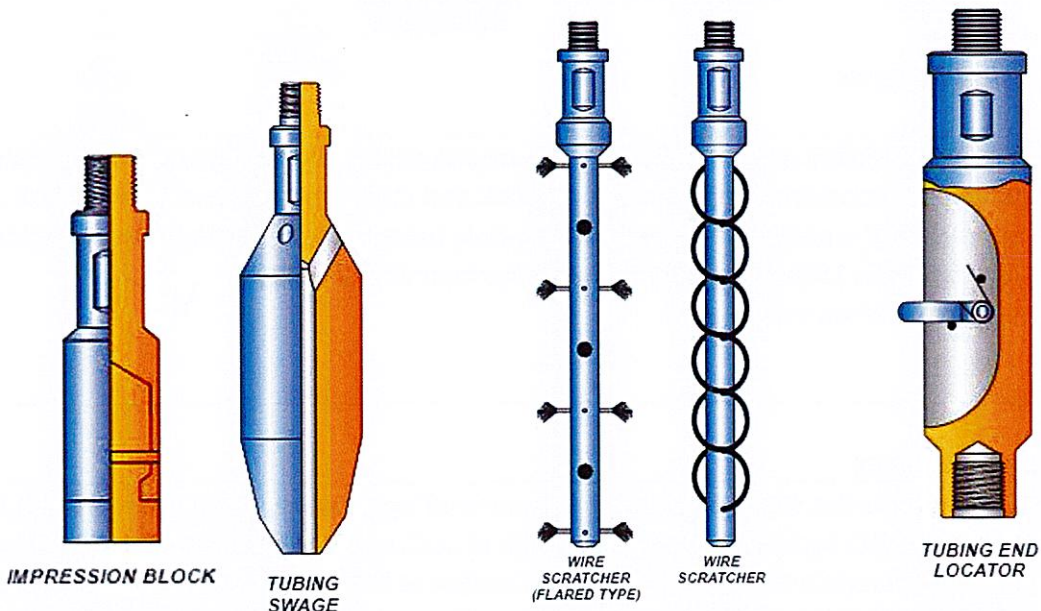
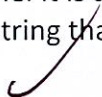

k) lead impression box

Also known as 'bottom-hole camera'. Is used during fishing operations to check the shape or size of the top of fish and to determine the appropriate tool for the fishing operation.

*[Handwritten Signature]*  
 Operation Manager  
 Dimension Bid (M) Sdn Bhd  
 Labuan Wireline Services  
 25/3/25



l) swage

Swage is used to restore the light collapse in the tubing and to remove large obstructions. It is recommended to run with hydraulic/spring jar to enable the operator to jar up out the tubing if the swage jam. ✓

m) wire scratcher ✓

It is a piece of brush-like tool. The function is to clear wax, scale and sand in the tubing wall. Nipple profiles, SSD sleeves and Side Pocket Mandrels. If the wire scratcher not effective in removing the depositions, guage cutter/ringand tubing broch will be used.

n) tubing end locator

To lock end of tubing and measure depth of tubing end at completion

o) wire recover tool

To fish/retrieve the wire

  
GAZALI MEHRY  
Operation Manager  
Dimension Bid (M) Sdn Bhd  
25/3/28  
Logan Warehouse  
Sliexline Services

Fill in below Table

<p>A. Size of wire that use in DB</p> <ol style="list-style-type: none"> <li>0.108" ✓</li> <li>0.125" ✓</li> <li>0.140" ✓</li> </ol>	<p>B. Breaking point of each wire ZERON type</p> <ol style="list-style-type: none"> <li>0.108"-2125 lbs ✓</li> <li>0.125"-3300 lbs ✓</li> <li>0.140"-4050 lbs ✓</li> </ol>
<p>C. Type of wire used in DB</p> <ol style="list-style-type: none"> <li>ZERON ✓</li> <li>ZAPP ✓</li> <li>EIPS (No more used)</li> </ol>	<p>D. How to test if wire is good or not</p> <ol style="list-style-type: none"> <li>Wire pull test ✓</li> <li>Torsion test ✓</li> </ol>
<p>E. Why do we need to check the tools before running in hole (RIH)?</p> <p>To ensure the toolstring functioning and tighten ✓</p>	
<p>F. What do we need to do if the tool is damage or lost in hole?</p> <ul style="list-style-type: none"> <li>Stop work ✓</li> <li>Report to FSM ✓</li> <li>Prepare fishing plan ✓</li> </ul>	
<p>G. What do we need to do if equipment failed to work?</p> <ul style="list-style-type: none"> <li>Report to FSM and town ✓</li> <li>Made discussion with client representative immediately ✓</li> <li>Minor troubleshoots ✓</li> <li>Request for mechanic/technician for major troubleshoots and request new equipment is equipment is equipment fail to function after repair ✓</li> </ul> <p style="text-align: right;">   <b>GAZALI MEHRY</b>        Operation Manager        Dimension Bid (M) Sdn Bhd        Labuan Warehouse        @lickline Services        25/3/25     </p>	



