

WIRELIN PREPARATION & MAINTENANCE

PRESENT BY

MUHAMMAD AIZUDDIN BIN MUSTAFFA 😊

SURFACE EQUIPMENT

Hydraulic Mast



INTRODUCTION

- Description of Mast
- Type of Hydraulic Mast
- Operating Procedure
 - a) Rig up
 - b) Rig down
- Safety Precautions
- Inspection and Maintenance
- Specification

TYPE OF HYDRAULIC MAST

- There are a few types of Hydraulic Mast ;
 - a) Telescopic Mast
 - b) Hydraulic Mast

There is also a mast the can reach up to 70FT, but normally for slickline, we usually using the 40FT mast.

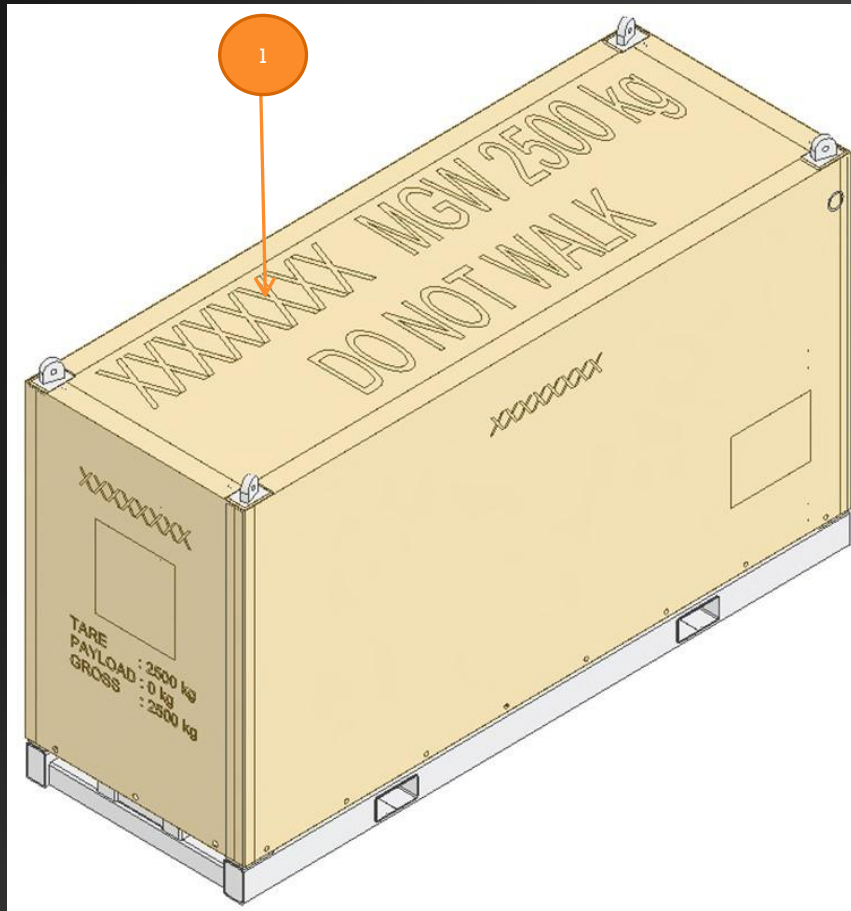

1) PVC Cover

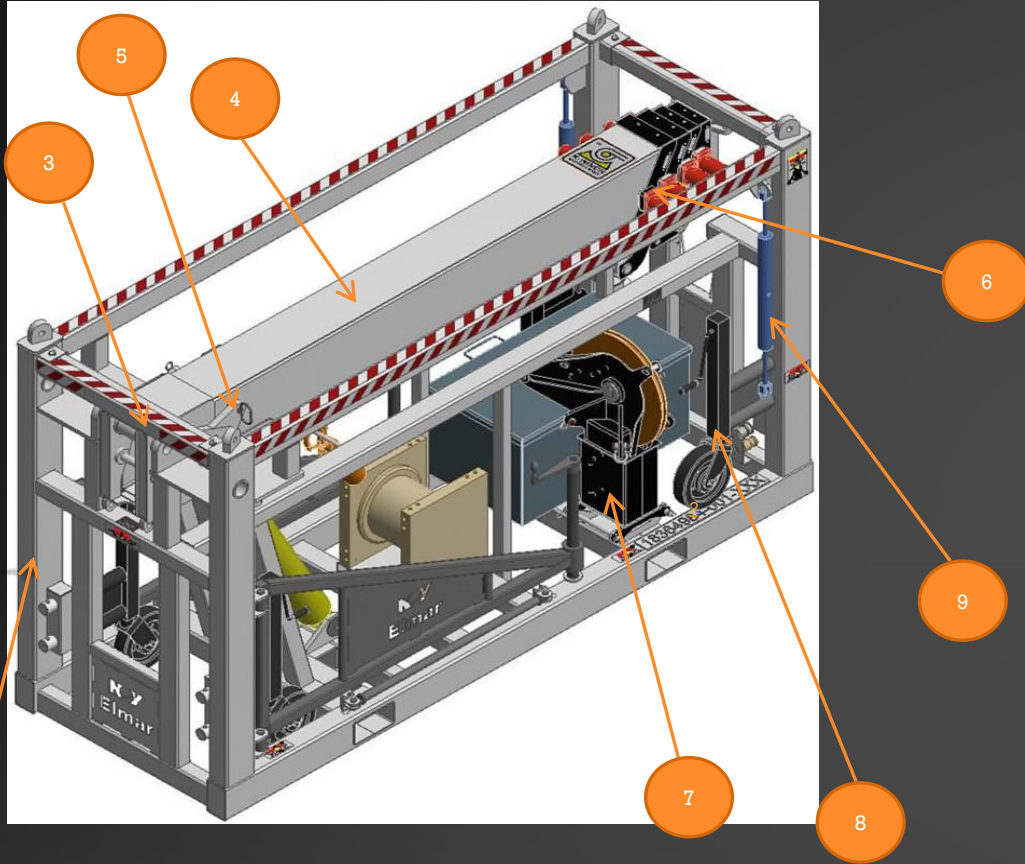

2) Frame assembly

3) Removable beams

4) 40ft mast column assembly

5) Column lock shaft

6) Booms locking cylinder

7) Sheave assembly

8) Jacking castor

9) Frame anchoring set

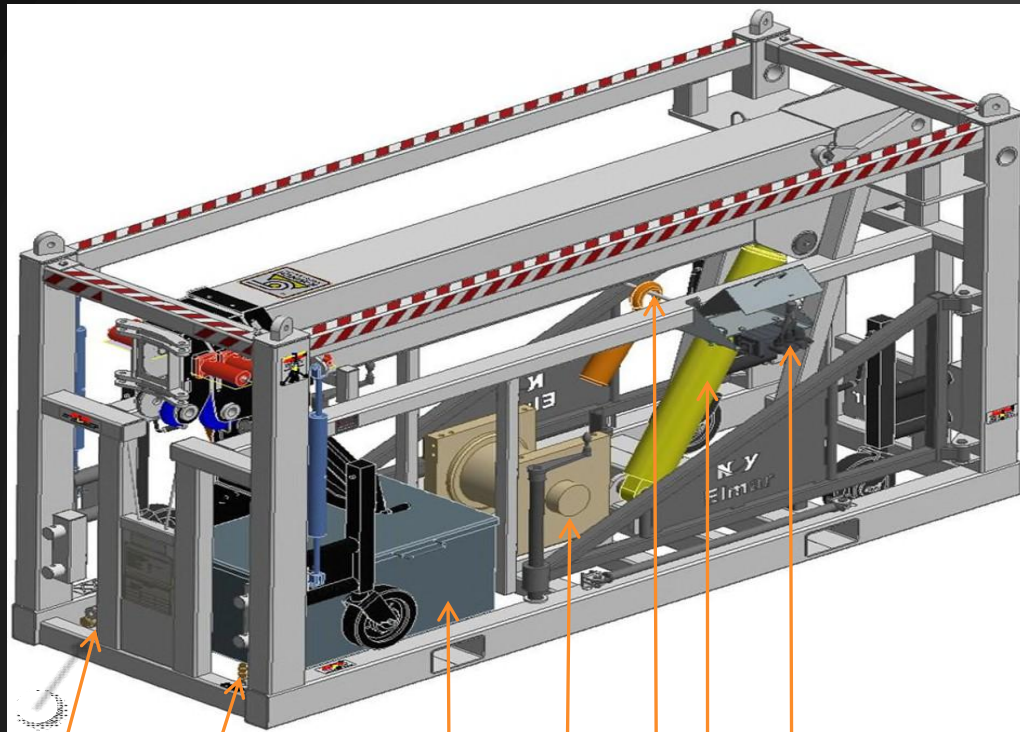

11

12

13

14

15

17

16

11) Bulkhead

12) Earthing point

13) Storage box

14) Utility winch

15) Winch hook assembly

16) Lifting cylinder

17) Control panel

OPERATING PROCEDURE

RIG UP

- a) Position and skid the mast away from the well centre and remove the hatch cover
- b) Remove removable beam fitted both sides of the frame
- c) Anchor the backside of the frame
- d) Fix the sheave assembly to the column end. Attach guy rope to the top of the mast sheave assembly. Detach the hook and operate the winch to spool out the wire. Run the wire through mast attachment and sheave wheel and then lock using pins
- e) Connect all hydraulic hoses to the bulkhead
- f) Operate the lifting cylinder to lift the mast to a vertical position
- g) Secure the mast with a column lock shaft
- h) Before extending the mast column, pull the boom telescopic lever to unlock the locking cylinders
- i) SLOWLY extend the mast column
- j) Simultaneously ensure the winch is operated to lower the hook to avoid the hitting of hook to the horse head
- k) Once the mast extended to its fully operating position, leave the boom telescopic lever and confirm that all locking cylinder operate to locking

OPERATING PROCEDURE

RIG DOWN

- a) Before retracting the mast, push the boom telescopic lever to unlock the locking cylinder
- b) Retract the mast SLOWLY
- c) Raise hook enough to retracting mast
- d) Release the shaft when the mast is fully retracted
- e) Lower the mast SLOWLY. Take care of hanging hook and not damaging the winch wire rope and guy rope
- f) Before folding the mast into full horizontal, release the winch wire rope from mast and sheave wheel. Operate the winch to spool the wire rope fully and then attach the hook to the anchoring points
- g) Lower the mast fully to its horizontal transportation position
- h) Remove all guy rope from sheave assembly and store inside storage box
- i) Detach the sheave assembly from the column end and store inside the frame
- j) Store the jacking castor inside the frame
- k) If optional outrigger is used, secure foldaway outrigger and store the foot pad inside the storage box
- l) Fix removable beam into the frame
- m) Attach lifting sling set to the frame pad eyes

SAFETY PRECAUTIONS

There are some safety precaution when handling the mast such as;

- a) Do not operate the mast with wind speeds over 60 knot
- b) Do not operate the mast during thunder showers
- c) Do not operate the mast if the mast have some damage or caution placards are missing or illegible
- d) The operating crew must know the SOP of the mast
- e) The position of the mast must not be near from electrical power line
- f) Do not operate the mast outside SWL (Safe working Load)
- g) Do not operate the mast if the unit have badly worn or frayed cable damage
- h) Avoid handling the mast using bare hands
- i) Never leave equipment with load suspended, if necessary lower the load to the ground
- j) A Minimum of (3) cable wraps must be remain on the winch drum
- k) Do not stand directly under the hooking during mast extracting and retracting

MAINTENANCE SCHEDULE

- CHECK POINTS AFTER A MONTH

- 1) Any oil leakage
- 2) Any untightened bolt and nut
- 3) Any loosened connecting part of hose and pipe
- 4) Any damage on hook
- 5) Is the operation of control valve smooth
- 6) Is the seal of pressure control device kept in good condition
- 7) Any crack or damage with the structural parts of mast
- 8) Any unusual noise from mast
- 9) Properly lubricate

INSPECTION AND MAINTENANCE

The importance of good regular maintenance can never be over-stressed as means of increasing equipment life expectancy.

Replacement of wire

The wire rope is consumable and thus will be worn out or damage gradually after long duration of use, therefore, replace it with new one as per following standard:

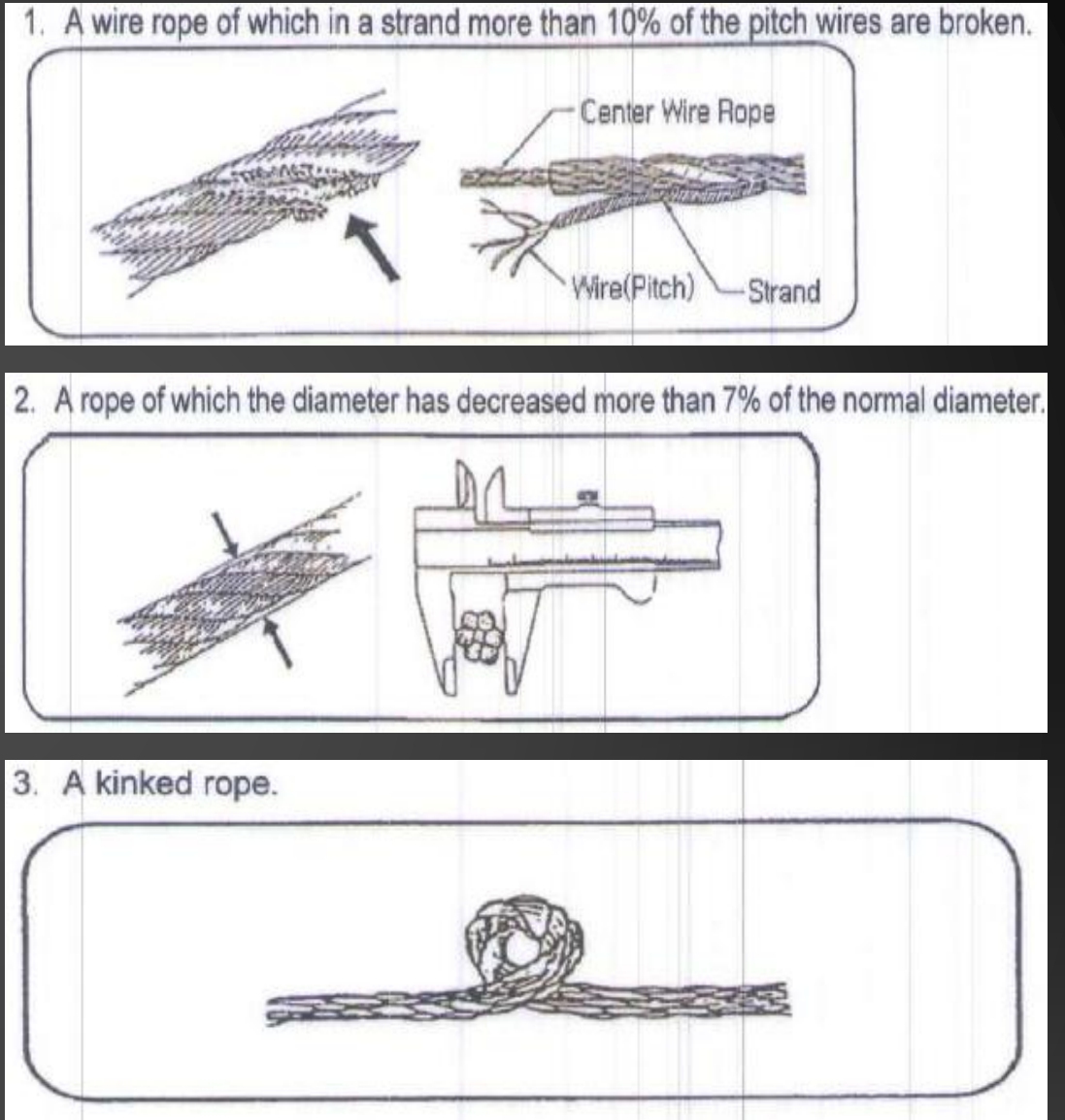

SPECIFICATION OF MAST

Appendix 1: Unit Specifications

18364984-001 – MAST 40FT TELESCOPIC 2T BASEREACH

Dimensions	
Transport dimensions (L x W x H)	3035 x 1100 x 1748 mm (9.96 x 3.61 x 5.74 ft)
Maximum gross weight	2500 kg (5512 lbs)
Tare weight	2500 kg (5512 lbs)
Payload	0 kg

Operating conditions	
Ambient operating temperature range	-20 °C to +55 °C (-4 °F to +131 °F)
Mast operating height	40 ft
Utility winch capacity	2 ton

Standard features	
Steel frame with forklift pockets and 4 pad eyes (Frame certified to DNV 2.7-1)	
Five sections hydraulically extendable telescopic mast column c/w 2 extensions cylinders, 2 extension wires and positive boom locking cylinders	
Horse head assembly with Sheave wheel	
1x Utility winch, SWL 2000 kg c/w Non-rotating wire 19x7, Ø 12 x 60 metre	
Erection hydraulic cylinder with counterbalance valve	
Control console	
1x Level indicator at the control console	
Storage box to store tools / Accessories	
PVC cover	
4x Wire pulling hoist with Guywires	
4x Jacking Castors	
2x Frame anchoring set	

SPECIFICATION OF MAST



Completion &
Production Solutions

No. 7 Loyang Way
Singapore 508721
Tel: +65 6546 0928
Web: www.nov.com

Fax: +65 6546 0927

OWNER : DIMENSION BID
IDENTIFICATION : 10FT BASEREACH MAST
PART NO. :
SERIAL NO. : 101534
MANUFACTURER : NOV
DATE OF MANUFACTURING : 20-2-25 (REFURB)
TARE WEIGHT : 1525KG
S.W.L. : 150KG PAYLOAD
GROSS WEIGHT : 1775KG
TEST LOAD : 1130 E. 4PTS
DATE OF LAST TEST : 2/2025
TEST ACCORDANCE : 1057072

THANK YOU FOR YOUR ATTENTION

