

# Non-Routine Job Presentation

**Name** : Ammirol Bin Ahmad Mahmud

**Client** : T7 Global

**Location** : M3DP-A

**Well** : 107

**Team Member** : Macdonald N, JoeShamantha J & Christoper M

**Topic** : Set & Retrieve BPV and Test Dart



# Table of Contents

- Surface Preparation
- Detail BHA
- Precaution during operation
- Parameter on Well
- Landing Nipple Introduction
- BPV Introduction
- Pulling & Running tools Introduction
- Running Sequence
- Redress Running/Pulling Tools
- Contingency plan
- Pre and Post Job Operational

# Surface Preparation



# PTW ( Permit to work )

## Require Cold and Hot Work Permit

- **Cold Permit** is for RIH (Rig Up/Down Lubricator Using Mobile Crane. To Performed Wireline Activity )
- **Hot Permit** is for Start and Run Power Pack Diesel Engine
- Here is the sample of Hot & Cold Work Permit for this operation.

**PERMIT TO WORK (HOT WORK)**  
NO WORK IS SO URGENT THAT WE CANNOT TAKE TIME TO DO IT SAFELY

Pre-Printed No: 000461  
Closed

SECTION 1: REQUISITION (APPLICANT/RA)  
APPLICANTS NAME: Arvince Terrence  
ID NO: 890730-13  
DATE: 13 Mar 2024  
AREA CLASSIFICATION (Answer Y/N): Zone 0  
SPECIAL WORK INSTRUCTIONS:  Confined Space Entry Cert. No.  Safety System Bypass/Override Cert. (NEW). No.  Lifting Cert. No.  Vehicle Entry Cert. No.  Portable Electrical Temporary Installation. No.  Excavation Cert. No.  Electrical Isolation Cert. No.  Physical Isolation Cert. No.  Radiation Cert. No.  Pressurised Habitat Certificate. No.

SECTION 2: HAZARDS/HAZARDOUS ACTIVITIES (APPLICANT BAS)  
Cross (X) where applicable:  Blasting,  Flammable,  Hot Tapping,  Photo Taking,  Spark Producing,  Welding,  Flame/Power,  Grinding,  Vehicle Entry,  Others.

SECTION 3: WORKSITE PREPARATION /PRECAUTIONS (APPLICANT/RA & AS)  
Mandatory:  Area barricade,  Bypass Required,  Clearance of escape route,  Contact Area Operator before work start,  Contact Area Operator on completion,  Equipment/line blind/rapped,  Equipment/line drained,  Equipment/line removal,  Fire extinguisher on work site,  H2 purged/ventilated,  Positive Removal of Energy (EC),  Positive Removal of Energy (ECC).

SECTION 4: PERSONAL PROTECTIVE EQUIPMENT (APPLICANT/RA & AS)  
Mandatory:  Coverall,  Helmet,  Safety Glasses,  Safety Shoes,  Ear Protection,  Respiratory Protection,  Hand Protection,  Personal monitoring Equipment.

SECTION 5: SUPPORTING CERTIFICATES/DOCUMENTS (AS)  
SECTION 6: ACKNOWLEDGEMENT REQUIRED AS IDENTIFIED BY APPROVING AUTHORITY (e.g. CSR)  
SECTION 7: AUTHORIZATION  
SECTION 8: JOINT SITE VISIT BEFORE WORK COMMENCES (AAR & RA/WL)  
SECTION 9: DAILY PERMIT RETURN AND SUSPENSION (WL & AAR) - due to e.g. End of Shift, Stop Work, Drift, Emergency etc.  
SECTION 10: DAILY REVALIDATION & ENDORSEMENT (WL, AAR & AA)  
SECTION 11: HANDBACK & CLOSE (WL, AAR & AA)

STOP WORK AND EVACUATE AREA ON HEARING ANY EMERGENCY ALARM

**PERMIT TO WORK (COLD WORK ONLY)**  
NO WORK IS SO URGENT THAT WE CANNOT TAKE TIME TO DO IT SAFELY

Pre-Printed No: 000623  
Closed

SECTION 1: REQUISITION (APPLICANT/RA)  
APPLICANTS NAME: Arvince Terrence  
ID NO: 890730-13  
DATE: 06 Mar 2024  
AREA CLASSIFICATION (Answer Y/N): Zone 0  
SPECIAL WORK INSTRUCTIONS:  Confined Space Entry Cert. No.  Safety System Bypass/Override Cert. (NEW). No.  Lifting Cert. No.  Vehicle Entry Cert. No.  Portable Electrical Temporary Installation. No.  Excavation Cert. No.  Electrical Isolation Cert. No.  Physical Isolation Cert. No.  Radiation Cert. No.  Pressurised Habitat Certificate. No.

SECTION 2: HAZARDS/HAZARDOUS ACTIVITIES (APPLICANT BAS)  
Cross (X) where applicable:  Blasting,  Flammable,  Hot Tapping,  Photo Taking,  Spark Producing,  Welding,  Flame/Power,  Grinding,  Vehicle Entry,  Others.

SECTION 3: WORKSITE PREPARATION /PRECAUTIONS (APPLICANT/RA & AS)  
Mandatory:  Area barricade,  Bypass Required,  Clearance of escape route,  Contact Area Operator before work start,  Contact Area Operator on completion,  Equipment/line blind/rapped,  Equipment/line drained,  Equipment/line removal,  Fire extinguisher on work site,  H2 purged/ventilated,  Positive Removal of Energy (EC),  Positive Removal of Energy (ECC).

SECTION 4: PERSONAL PROTECTIVE EQUIPMENT (APPLICANT/RA & AS)  
Mandatory:  Coverall,  Helmet,  Safety Glasses,  Safety Shoes,  Ear Protection,  Respiratory Protection,  Hand Protection,  Personal monitoring Equipment.

SECTION 5: SUPPORTING CERTIFICATES/DOCUMENTS (AS)  
SECTION 6: ACKNOWLEDGEMENT REQUIRED AS IDENTIFIED BY APPROVING AUTHORITY (e.g. CSR)  
SECTION 7: AUTHORIZATION  
SECTION 8: JOINT SITE VISIT BEFORE WORK COMMENCES (AAR & RA/WL)  
SECTION 9: DAILY PERMIT RETURN AND SUSPENSION (WL & AAR) - due to e.g. End of Shift, Stop Work, Drift, Emergency etc.  
SECTION 10: DAILY REVALIDATION & ENDORSEMENT (WL, AAR & AA)  
SECTION 11: HANDBACK & CLOSE (WL, AAR & AA)

STOP WORK AND EVACUATE AREA ON HEARING ANY EMERGENCY ALARM

# JHA ( JOB HAZARD ANALYSIS )

**A job hazard analysis is a technique that focuses on job task as a way to verify hazard before they occur**

- Before getting approval and submit our PTW, JHA must being attached to our permit for SSE to verified.
- All relevant hazard for our task must being captured and put inside the JHA before submitting.
- Here is the sample of JHA Precautionary Control barrier (JPBC) check for this job before start operation that we need to verified every 2 hours .

**Hot Work**

**COLD WORK**

No.	JHA Barriers (Date: _____ )	Barrier Verification Frequency (Tick ✓ and timestamp where applicable)					
1	Barricade area of hazard						
2	Keep worksite clear from slippery/tripping hazards/obstructions of escape route						
3	Maintain housekeeping during the working period						
4	Ensure equipment is inspected and in good condition						
5	Ensure guard is provided						
6	Bleed off any trapped pressure						
7	Verify to ensure zero pressure inside						
8	Ensure guard is provided						
9	Keep worksite clear of pinch point/sharp object hazards						
10	To ensure housekeeping performed at the end of the day						

No.	JHA Barriers (Date: _____ )	Barrier Verification Frequency (Tick ✓ and timestamp where applicable)					
1	Barricade area of hazard						
2	Be vigilant on footing/watch the footsteps.						
3	Keep worksite clear from slippery/tripping hazards/obstructions of escape route						
4	Maintain housekeeping during the working period						
5	Correct hand placement/ positioning						
6	Usage of tag line to control the load from safe distance						
7	Correct hand placement/ positioning						
8	Local weather forecast report from onshore						
9	Cover any potential sharp edges with cotton rag						
10	Correct hand placement/ positioning						
11	At least 2 tag line to be attached to the opposite end of the load to assist the control of lifting lowering/ positioning for long or bulky loads						
12	Barricade working area						
13	Others						
14	Barricade working area						
15	Correct hand placement/ positioning						
16	Monitor and analyses LEL and PEL						

# Spot Equipment

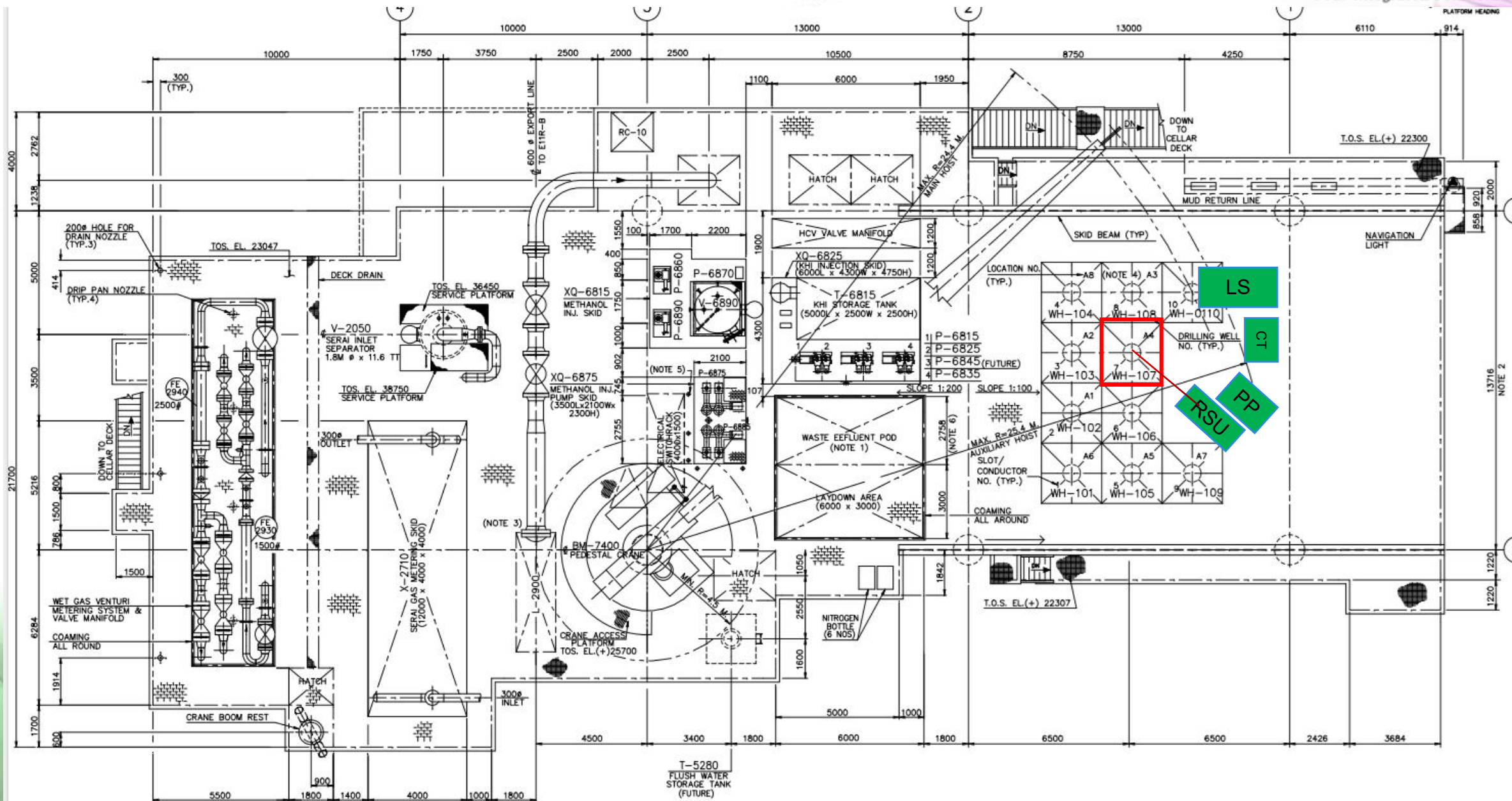

LS  
CT  
PP  
RSU

NOTE 2  
13716

# PCE Stack Up

## Hydraulic Stuffing Box

3" 5-4 Acme Stuffing Box

## X-Over

8.3/8 x 5-4

## Lubricator 8FT

2 Section 8.3/8" Lubricator Section

## X-Over

11.5" x 8.3/8"

## QTS ( Quick Test Sub )

11.5" QTS

## Dual Hydraulic BOP

11.5" Hydraulic BOP

## Pump In Tee

11.5" Pump in Tee

## Pup Joint 8FT

11.5" Riser

## Hydraulic Ball Valve

11.5" Hydraulic Valve

Appendix 1.0: WPCE

End of 16" Stuffing Box

End of Lub section

Wireline Deck

Crown Valve

Master Valve

Total length to accommodate tools (4 lub section) 32 ft

Top of XMT to WL Deck 12 ft

Neu  
Dimension  
Your Integrated Solutions Partner

# Detail BHA ( Bottom Hole Assembly )



# Toolstring Configuration

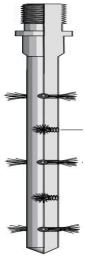

## **7" Wire Scratcher**

1-7/8" Rope Socket + 1-7/8" Swivel Joint + 2.5" 5 ft Normal Stem + 2.5" Link Jar + 1-7/8" Male QLS + X-Over + Female QLS

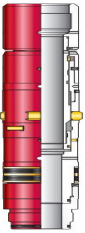

## **CRQ Lock Mandrel attached with BPV**

1-7/8" Rope Socket + 1-7/8" Swivel Joint + 2.5" 5 ft Normal Stem + 2.5" Link Jar + 1-7/8" Male QLS + X-Over + Female QLS

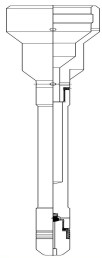

## **BPV Test Dart**

1-7/8" Rope Socket + 1-7/8" Swivel Joint + 2.5" 5 ft Normal Stem + 2.5" Link Jar + 1-7/8" Male QLS + X-Over + Female QLS

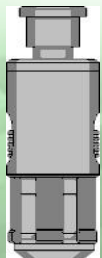

## **7" GS**

1-7/8" Rope Socket + 1-7/8" Swivel Joint + 2.5" 5 ft Normal Stem + 2.5" Link Jar + 1-7/8" Male QLS + X-Over + Female QLS

# Toolstring Details

**RIH 7" Wire Scratcher**

No	Description	Length (ft )	Weight (lbs)
1	1-7/8" Rope Socket	0.5	5.0
2	1-7/8" Swivel Joint	0.5	5.0
3	2.5" Normal Stem	5	60
4	2.5" Link Jar	5	18
5	7" Wire Scratcher	3	5

**RIH CRQ c/w BPV**

No	Description	Length (ft )	Weight (lbs)
1	1-1/2" Rope Socket	0.5	4.0
2	1-1/2" Swivel Joint	0.5	3.0
3	2.5" Normal Stem	5	60
4	2.5" Link Jar	5	18
5	CRQ c/w BPV	6	160

**RIH BPV Test Dart**

No	Description	Length (ft )	Weight (lbs)
1	1-7/8" Rope Socket	0.5	5.0
2	1-7/8" Swivel Joint	0.5	5.0
3	2.5" Normal Stem	5	60
4	2.5" Link Jar	5	18
5	7" Wire Scratcher	3	25

**RIH 7" GS**

No	Description	Length (ft )	Weight (lbs)
1	1-7/8" Rope Socket	0.5	5.0
2	1-7/8" Swivel Joint	0.5	5.0
3	2.5" Normal Stem	5	60
4	2.5" Link Jar	5	18
5	7" GS	3	30

# Precaution During Operation



# **Precaution During RIH & POOH**

- Make sure using the right size of toolstring configuration corresponding to the tubing size.
- set the toolstring “zero” reference depth on the odometer.
- Pressurize the lubricator slowly to well “CITHP” then open x-mas tree
- RIH in moderate speed. Slow down when passing thru tubing accessories. Noted the F/L.
- If any resistance is encountered on the way down, DO NOT attempt to jar through. Make a few attempts by tapping down only.
- If toolstring is held up and unable to be tapped through, pull out of hole.
- While POOH, take noted of the PW of the toolstring until surface.
- When toolstring at surface, closed the swab valve and depressurize pressure inside lubricator
- Capture or Inform if any abnormality found on running/pulling tools inside DOR.

# Parameter On Well M3-107



FINAL COMPLETION DESIGN

Well No.: M3-107 Location: M3DR-A4  
 Mas Tree: 6.5/8" bore single FMC DM-3 with tension type of hanger.  
 Tubing: 7.5/8" 33.7# Vam Top Super13 CR, 5.1/2" 20# Vam Top Super13 CR,  
 4" 14.8# Vam Atac 13CR Tail.

Date Completed: 14-03-1995  
 All Depths in FT. AH BDF SEDCO 600  
 DFE 106 ft. AMSL  
 Maximum Deviation: 45° @ 6642'

THF - 0000ft  
 QN Landing  
 Nipple / Tubing  
 Hanger

**Well Schematic For 107**

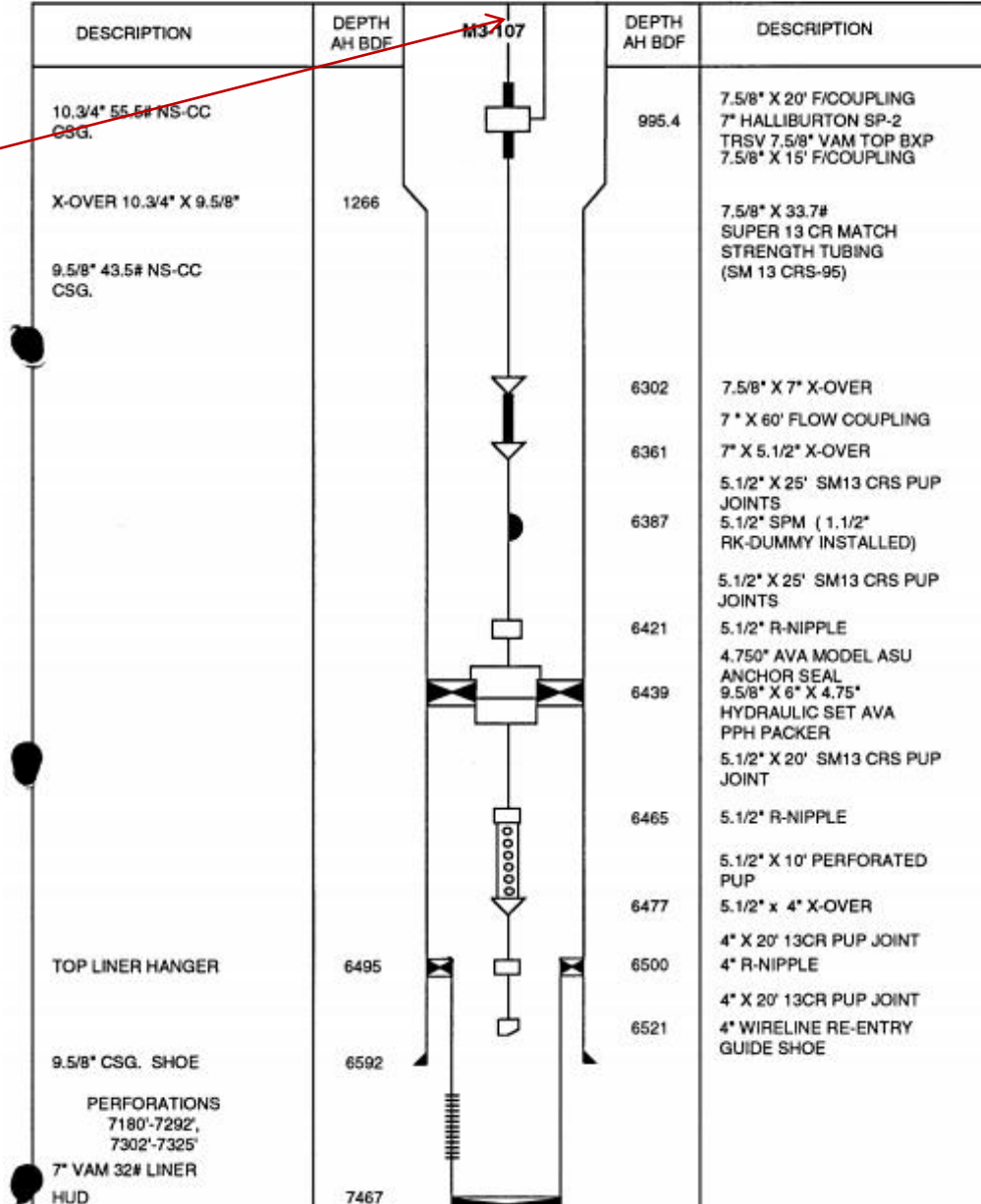

# Toolstring Parameter

**RIH 7" Wire Scratcher**

THF-Depth (ft)	R/W (lbs)	P/W (lbs)	H/W (lbs)
00000	90	110	90

**RIH CRQ c/w BPV**

THF-Depth (ft)	R/W (lbs)	P/W (lbs)	H/W (lbs)
0000	200	400	350

**RIH BPV Test Dart**

THF-Depth (ft)	R/W (lbs)	P/W (lbs)	H/W (lbs)
00000	110	300	100

**RIH 7" GS**

THF-Depth (ft)	R/W (lbs)	P/W (lbs)	H/W (lbs)
00000	120	350	150

# Well Condition

## Pressure on THP & CHP

- CITHP : 0 psi
- CHP : 0 psi

THP is 0 psi due to the well have been cemented/kill.

## During RIH

- No abnormalities during RIH / POOH CRQ Plug & Pulling the CRQ Test Dart

# QN/QNB Landing Nipple



# Introduction QN Landing Nipple

***Weatherford's Uniset QN/QNB landing nipple is used to seat Uniset QX lock mandrels. By using a no-go principle, the QN/QNB eliminates the need for complex manipulation downhole***

## **Features, Advantages and Benefits**

- No-go design provides a positive locating shoulder for any flow control device deployed in the nipple profile. In addition, the QN/QNB no-go is smaller than conventional nipples, minimizing the taper effect in the completion architecture.
- Pressure loads on plugs or standing valves are taken at the key groove in the nipple profile, ensuring pressure system integrity for the life of the well.
- High-specification, honed seal bore minimizes scale deposits and prevents corrosion.
- Streamlined internal profile minimizes pressure losses and turbulence.
- 15° entry angle facilitates installation of flow controls in highly deviated wells.
- The QN/QNB landing nipple is available in either a top or a bottom no-go configuration to provide flexibility in the completion design.

# QN Nipple Profile

Tubing Size		Seal Bore		No-Go Minimum ID				Maximum OD
				QN Top		QNB Bottom		
(in.)	(mm)	(in.)	(mm)	(in.)	(mm)	(in.)	(mm)	
2-3/8	60.33	1.781	45.23	1.781	45.23	1.716	43.59	Coupling OD
		1.813	46.05	1.813	46.05	1.748	44.39	
		1.875	47.62	1.875	47.62	1.810	45.98	
2-7/8	73.02	2.125	53.98	2.125	53.98	2.060	52.32	Coupling OD
		2.235	56.77	2.235	56.77	2.170	55.12	
		2.300	58.42	2.300	58.42	2.235	56.77	
3-1/2	88.90	2.480	62.99	2.480	62.99	2.415	61.34	Coupling OD
		2.550	64.77	2.550	64.77	2.485	63.12	
		2.562	65.07	2.562	65.07	2.497	63.42	
		2.635	66.93	2.635	66.93	2.570	65.28	
		2.650	67.31	2.650	67.31	2.585	65.66	
		2.680	68.07	2.680	68.07	2.615	66.42	
		2.750	69.85	2.750	69.85	2.685	68.20	
		2.813	71.45	2.813	71.45	2.748	69.80	
4	101.60	3.125	79.37	3.125	79.37	3.060	77.72	Coupling OD
		3.313	84.15	3.313	84.15	3.240	82.30	
4-1/2	114.30	3.437	87.29	3.437	87.29	3.367	85.52	Coupling OD
		3.562	90.47	3.562	90.47	3.592	91.24	
		3.625	92.07	3.625	92.07	3.555	90.30	
		3.658	92.91	3.658	92.91	3.588	91.14	
		3.688	93.68	3.688	93.68	3.618	91.90	
		3.735	94.86	3.735	94.86	3.665	93.09	
5	127.00	3.750	95.25	3.750	95.25	3.680	93.47	Coupling OD
		3.937	100.00	3.937	100.00	3.867	98.22	
		4.000	101.60	4.000	101.60	3.930	99.82	
		4.125	104.77	4.125	104.77	4.055	77.60	
5-1/2	139.7	4.250	107.95	4.250	107.95	4.180	106.17	Coupling OD
		4.313	109.55	4.313	109.55	4.243	107.77	
		4.375	111.13	4.375	111.13	4.305	109.35	
		4.437	112.70	4.437	112.70	4.367	110.92	
		4.562	115.87	4.562	115.87	4.492	114.10	
		4.625	117.48	4.625	117.48	4.555	115.70	
7	177.80	4.688	119.08	4.688	119.08	4.618	117.30	Coupling OD
		4.750	120.65	4.750	120.65	4.680	118.88	
		5.500	139.70	5.500	139.70	5.410	137.41	
		5.625	142.88	5.625	142.88	5.535	140.59	
		5.750	146.05	5.750	146.05	5.660	143.76	
		5.813	147.65	5.813	147.65	5.723	145.36	
7	177.80	5.875	149.23	5.875	149.23	5.785	146.94	Coupling OD
		5.980	151.89	5.980	151.89	5.890	149.61	

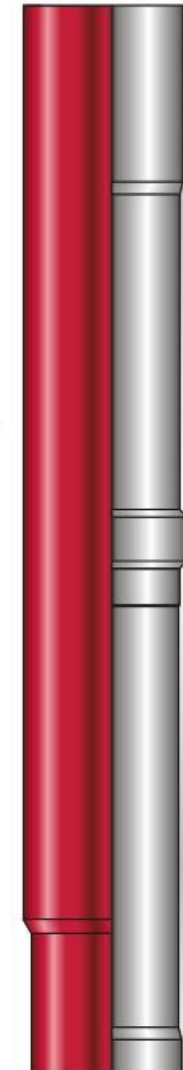

**QN Landing Nipple**

# BPV , CRQ Lock Mandrel & Test Dart



# Technical Information – 5.700in. Back Pressure Valve

- **Current Number** : 02551914
- **Legacy Number** : 216-5700-000-005
- **Pressure Rating** : 10,000 psi (Working Pressure)
- **Metallic Material** : 17-4PH Stainless Steel (105 ksi MYS)
- **Heat Treatment** : Q.P.Q. Process
- **Elastomer Material (T-Seals)** : FKM
- **Coil Spring Material** : MP35N
- **Upper Connection** : 5.700in. 10K POP Box
- **Lower Connection** : Bullnose End
- **Flow Area** : 4.927in<sup>2</sup>  
(Through Flow Ports)
- **For Use With 6.550in. CRQ Lock** : 266-6550-000-001 (02550137)
- **5.700in. PT Equalising Assembly** : 220-5700-000-004 (00884568)

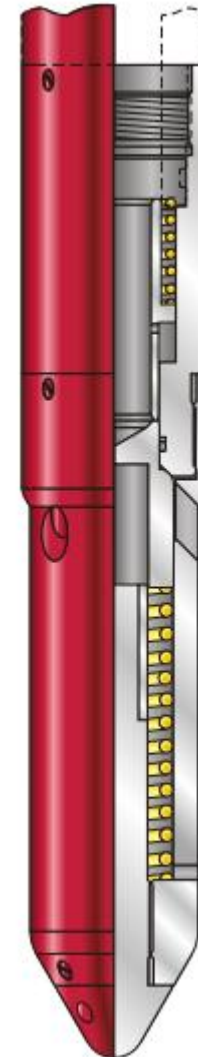

# Back Pressure Valve Introduction

## ***BPV Introduction***

- Flow control device to hold pressure from below allowing pump through when required
- Dual seal capability with metal-to-metal seal on radiused face & electromatic backup
- Type-C BPV can be supplied with pressure ratings up to 20,000 psi with 10,000 psi as standard

## ***Features***

- Dual Sealing Capability
- Metal to Metal primary sealing design
- Protected seals and seal faces during pumping operations
- Mechanical opening capability using bleed down prong
- Large flow area for high volume pumping

# Back Pressure Valve Introduction

## ***Benefits***

- Pump through capability for increased safety
- Low cost maintenance costs
- Field redressable

## ***Applications***

- Well completion operations
- Barrier during work-over operations
- Barrier during tree or wellhead maintenance

# Technical Information – 6.550in. CRQ Lock Mandrel

- **Current Number** : 02550137
- **Legacy Number** : 266-6550-000-001
- **Product Model** : CRQ
- **Product Type** : Top – Lifts off No-Go
- **Special Clearance** : 6.605in (167.767mm)
- **Pressure Rating (above)** : 5,000 psi (Working Pressure)
- **Pressure Rating (below)** : 5,000 psi (Working Pressure)
- **Metallic Material** : 17/4PH (105 ksi MYS)
- **Elastomer Material** : FKM (Viton)
- **Lock Body Tensile Strength** : 336,185 lbs (Through Box Thread)
- **Fishing Neck Size / Style** : 7.0in. GS Internal
- **Lower Connection** : 5.700in. 10K POP Pin

## Associated Equipment

<b>6.550in. CRQ Running Tool</b>	466-6550-000-001 (02550159)
<b>5.700in. (10K) PT Equalising Assembly</b>	220-5700-000-004 (00884568)
<b>5.700in. (10K) Back Pressure Valve</b>	216-5700-000-005 (02551914)
<b>3.500in. (10K) Test Dart</b>	213-3500-000-005 (02551872)
<b>5.700in. PT Running Prong</b>	220-5700-000-002 (00783036)
<b>5.700in. PT Equalising/Pulling Prong</b>	220-5700-000-008 (00917687)
<b>7.000in. GS Pulling</b>	

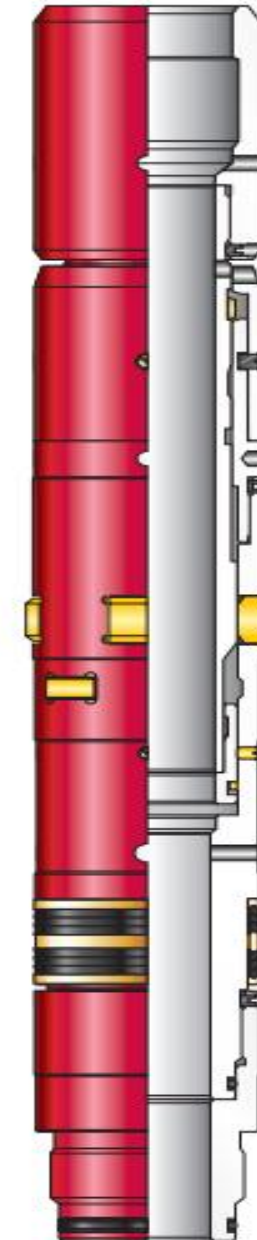

# CRQ Lock Mandrel

## **Features**

- Retractable No-Go Keys to engage no-go in landing nipple profile, and which retract after the lock out keys are fully expanded
- Drive-down Fishing Neck to expand locking keys into key groove of landing nipple profile
- Snap Ring hold down on expander mandrel
- Running tool secured to fishing neck with retainer dogs, not shear pins
- Telltale in running tool to indicate CRQ fishing neck has been driven down its full travel
- Running Tool core shear-pinned to lock body, allowing check pull before shearing off
- Retrieval does not require reversal of snap the fishing neck retracts the expander mandrel by shearing the releasing ring lock down. Jarring up on shear pins in the lock body, de-supporting the lock out keys 10,000 psi WP or 15,000 psi WP (as standard)
- All conventional Uniset® plugging and injection flow control devices can be attached according to the desired functionality.

# Test Dart

## **Features**

- Integral relief check valve
- Interchangeable fishing necks

## **Benefits**

- Temporary or long term installation
- Allows pressure testing from above

## **Applications**

- Completion Installation
- Workover Operations
- Well suspension

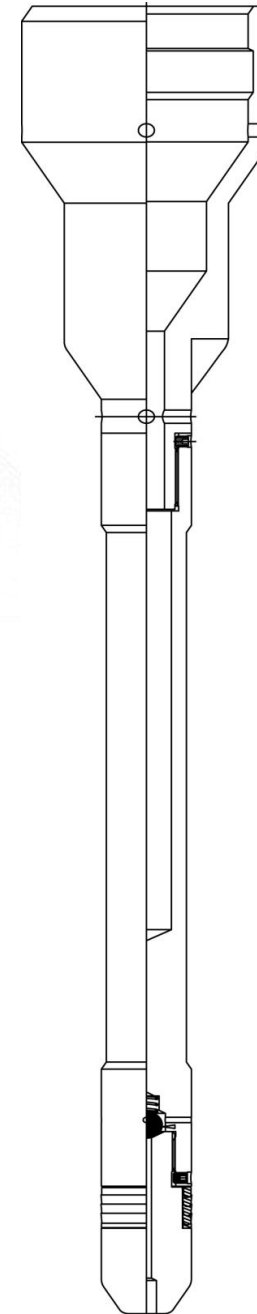

# Technical Information – 3.500in. Test Dart

**Current Number** : 02551872

**Legacy Number** : 213-3500-000-005

**Working Pressure** : 10,000 psi (From Above Only)

**Metallic Material** : 17-4PH Stainless Steel (105ksi MYS)

**Heat Treatment** : Q.P.Q. Process

**Coil Spring Material** : Inconel X750

**Elastomer Material (Vee Packings)** : FKM

**Fishing Neck Size / Style** : 7.00in. GS Internal

**For Use With** : 6.550in. CRQ Lock 266-6550-000-001 (02550137)

# Type of Running Tools & Pulling Tools



# Technical Information – 6.550in. CRQ Running Tool

**Current Number :** 02550159

**Legacy Number :** 466-6550-000-001

**Metallic Material :** AISI 4130-45 (110 ksi MYS)

**Metallic Coating :** Parkerise

**Upper Connection :** 2-1/2in QLS Male

**Lower Connection :** 2in-12UN Box

**For Use With :** 6.550in CRQ Lock: 266-6550-000-001 (02550137)

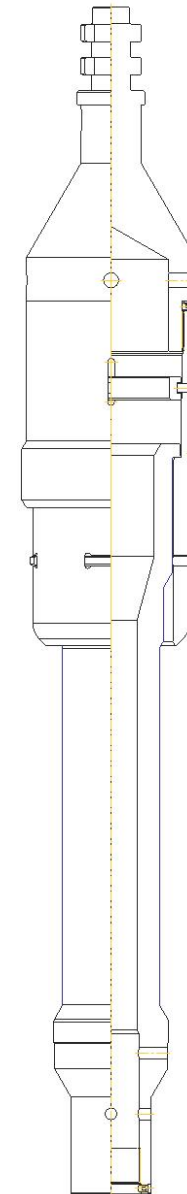

# Introduction – CRQ Running Tool

**The Weatherford CRQ Running Tool is used to run and set CRQ Lock Mandrels.**

The CRQ has been developed specifically to provide a lock mandrel to retrofit existing Uniset QN nipples. The specification requirements for use with injection valves include: -

- Downwards traveling expander mandrel to secure keys in the locked out position.
- No annular or reducing volume pockets where sand, proppant, slurry or other solids could accumulate and impede installation or recovery.

# Introduction – CRQ Running Tool

**The CRQ Lock design complies with these requirements, and also include the following: -**

- Internal fishing neck for increased strength and improved removal of junk fouling the top of the lock.
- Chamfered keys mounted in fully engineered key windows for increased strength and improved retraction of the keys.
- Elimination of trapped volume pockets for setting and retrieval in high debris or slurry environments.
- Separate mechanisms for expander mandrel lock down and expander mandrel release bring great improvement in retrievability even in the most adverse recovery situations.
- Running tool incorporates telltale to indicate full travel of fishing neck and expander mandrel to set lock.

**The telltale must be sheared on Running Tool retrieval to indicate successful CRQ setting operation.**

- Running tool design allows for check pull on lock before shearing off

# Uniset PT Running Prong

The complete P.T Equalising Assembly is then installed over the P.T Running Prong (assembled to the lower end connection of the CRQ Running Tool Assembly and installed in position within the CRQ Lock).

## Technical Data for 5.700in. PT Running Prong

Length (A)	Length (B)	Body OD (C)	Body OD (D)	Collet OD (E)	Collet OD (F)	Finger (F)
442.2mm	401.2mm	70.0mm	75.5mm	75.5mm	79.90mm	88.9mm
17.41in	15.80inc	2.756in	2.972in	2.972in	3.146in	3.50in

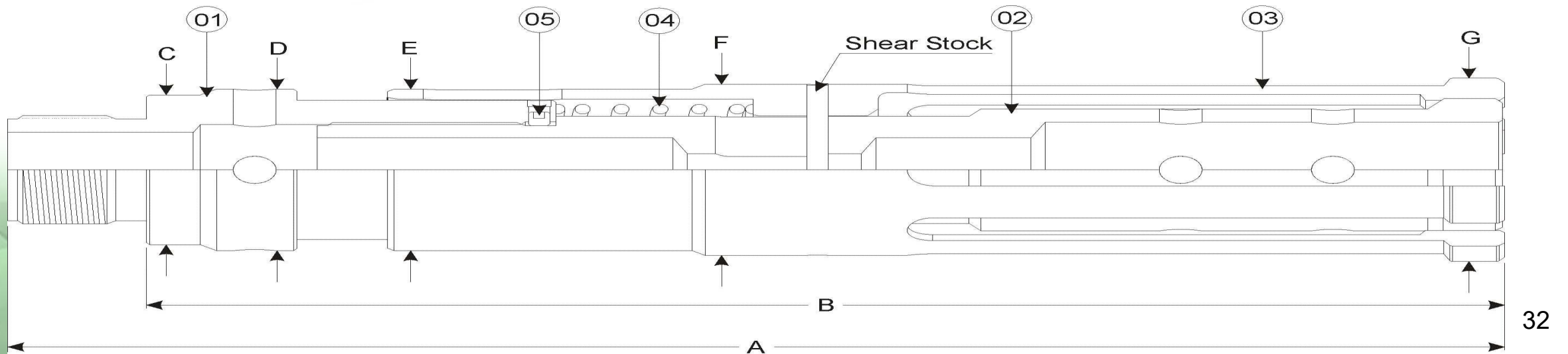

# GS Pulling Tool

The Otis 'GS' is a jar down to shear pulling tool to latch internal fishing necks.

- **Latching** : As the GS passes downwards into fishing neck the dogs move up and inwards to pass ID of fishing neck. Then the dog spring forces them back downwards
- **Pulling** : Upward movement transmitted from toolstring through core to the dogs which are now firmly expanded beneath fishing neck
- **Shearing** : Downwards jar force is applied to move the core downwards relative to the skirt

For this Well we are using 7.00in GS to retrieve the CRQ Lock Mandrel

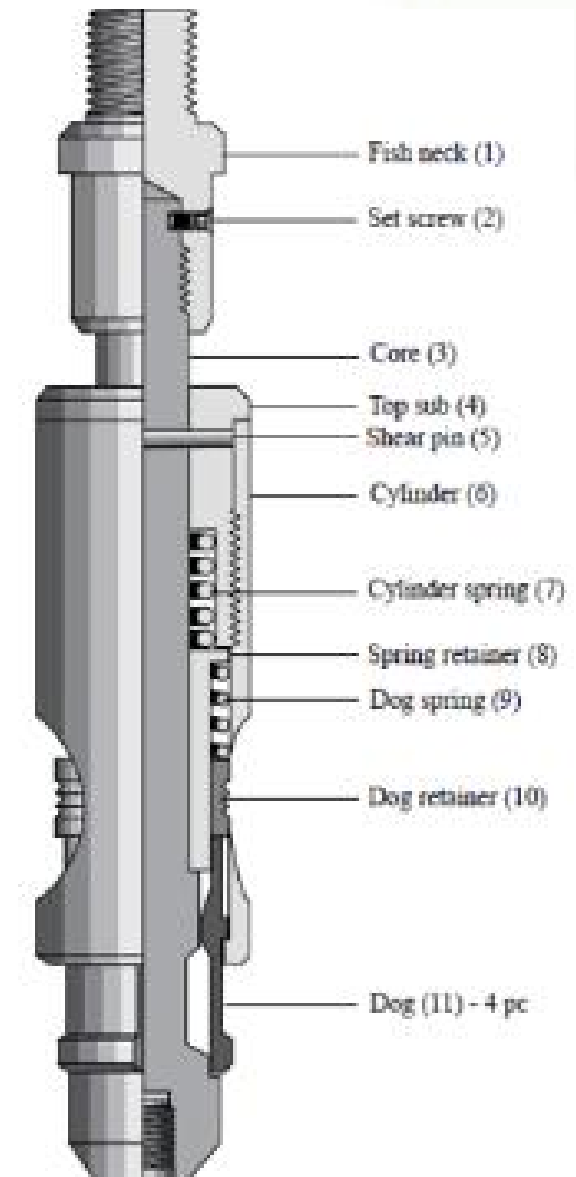

# Running Sequence



# CHC/Flow Controls - CRQ Running Procedure

## Procedure for Slickline Setting CRQ Assy in Tbg Hgr Profile

1. Attach the made up CRQ Tubing Hanger Plug assembly to the Slickline tool string.
2. Run assembly on Slickline until the CRQ Lock locates against the QN profile No-Go shoulder. Note that light downward jarring may be required to overcome seal friction
3. Jar down to shear out the setting shear screws, apply additional downwards jarring to ensure the CRQ is correctly set.
4. Once it is confirmed that the lock is fully set, take an upwards check pull of 200lbs above pick-up weight to ensure the CRQ Lock is fully set in the QN profile. Note – a correctly set lock will only move  $\frac{1}{4}$ " –  $\frac{1}{2}$ " within the profile.
5. If no movement greater than  $\frac{1}{4}$ " –  $\frac{1}{2}$ " is detected, jar up to shear out the main shear pin holding the running tool in place and retrieve the CRQ Running Tool / PT Running Prong from CRQ Lock. Do not allow Running Tool to fall back down into Lock at this point
6. Check the Running Tool Shear Ring (**tell-tale feature**) through the "window" to ensure it has sheared out its shear stock and is able to move within the bore of the Running Tool top sleeve. This shows that the CRQ Lock main keys are fully expanded.
7. Check the Running Prong Collet Shear Pin to ensure it has sheared.

# Test Dart Running Procedure

## **Procedure for Slickline Setting Test Dart**

1. Attach the appropriate size GS tool (Brass shear pin) and Test Dart to the Slickline tool string.
2. Run the test dart assembly until it lands out in the CRQ tubing hanger plug; Lightly jar downwards to ensure seals enter seal bore then jar down until the GS shears.
3. Once it is confirmed that the test dart is set, retrieve the GS to surface.
4. Break out the GS and confirm that the test dart has been left in the CRQ tubing hanger plug

## **Procedure for Slickline to Pull Test Dart**

1. Ensure pressure is bled off above the test dart. Make up and run the appropriate size GS until it tags the test dart, the toolstring weight should be sufficient (about 75 lbs min) for the GS to latch the fish neck however a light tap down with the Jars will confirm that the GS is latched. Pick up, take an overpull and the test dart should come free. If not, jar upwards lightly and the test dart should come free.
2. Retrieve the GS and Test Dart and visually inspect the tools for damage.
3. Remove the GS from the Test Dart, visually check the steel shear pin is still good then attach the equalising prong, tighten and secure with the grub screw

# CHC/Flow Controls - CRQ Pulling Procedures

## Procedure to Equalise and Pull CRQ Lock (One Run Prong)

1. Assemble the PT Equalising Prong as per relevant assembly instructions.
2. Assemble the appropriate GS Pulling Tool as per relevant assembly instructions.
3. Attach the PT Equalising Prong to the lower end connection of the GS Pulling Tool
4. Attach the GS and equalising prong to the Slickline tool string.
5. If possible match pressure above/below the Tubing Hanger Plug. Run the GS and equalising prong and tag CRQ Lock tubing hanger plug, lightly tap down to move the equalising melon off seat, check for any variation in well pressure.

Note: Make sure there is enough time for any remaining differential pressure to equalise across the tubing hanger plug.

6. Once confirmed equalised, continue jarring down to shear out the equalising prong shear sleeve allowing the GS to latch into the fishing neck of the CRQ tubing hanger lock profile.
7. Confirm GS latched by taking an over-pull of 200 lbs.
8. Start jarring upward to shear out the retrieval shear screws in the CRQ lock, continue upward jarring to retrieve the CRQ tubing hanger plug system.
9. Retrieve the CRQ tubing hanger plug to surface and visually inspect for any obvious damage and that everything is recovered.

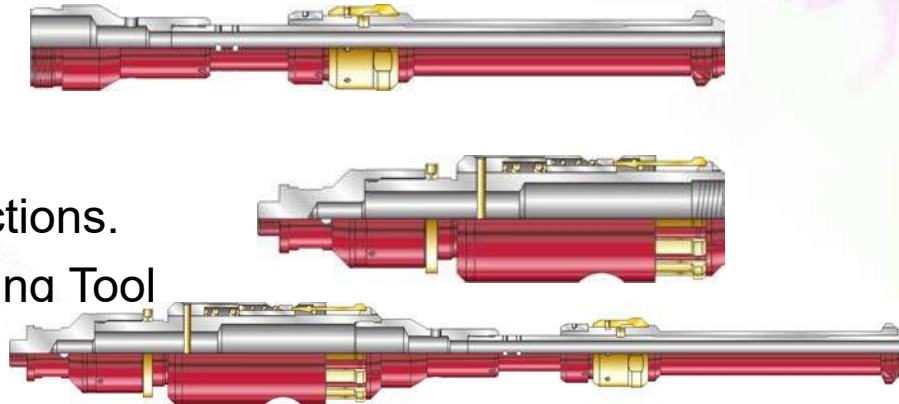

# RIH / POOH



# Redress Running / Pulling Tools



# CRQ Running Tool Redress

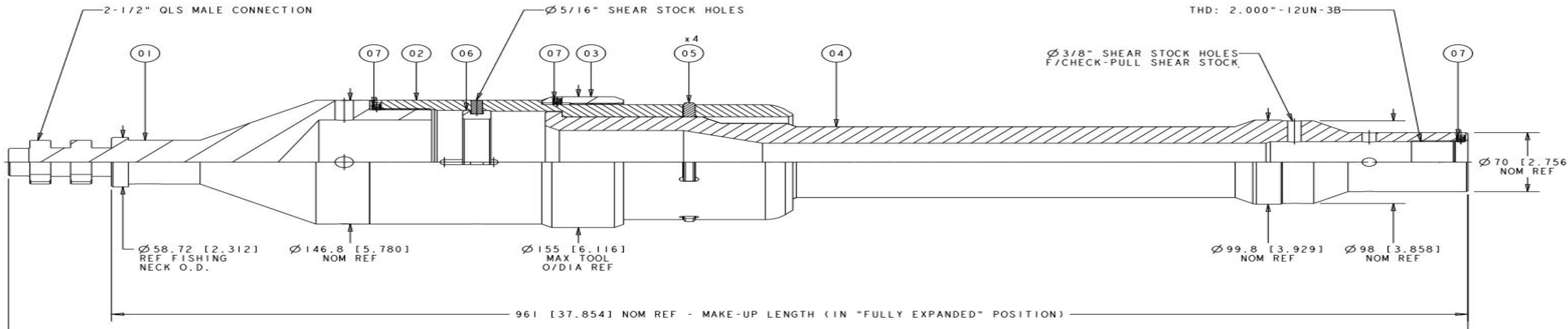

## **Assembly Instructions**

- Carefully stand the Upper Sleeve (Item 02) on its box end. Thread the Adjustable Lock Down Ring (Item 03) onto the Upper Sleeve until it bottoms out on shoulder secure with Grub Screw (Item 07).
- Flip the Upper Sleeve over with the box thread upwards. Install the No-Go Keys (Item 05) into the windows in the Upper Sleeve. A small amount of clean grease will help to retain keys.
- Install the Main Body (Item 04) down into the Upper Sleeve. Install the Grub Screw (Item 07) into Main Body.
- Install the Tell Tale Ring (Item 06) down into the Upper Sleeve and install 2-off 5/16in. Brass Shear Stocks through as shown.
- Thread the Top Sub (Item 01) to the Upper Sleeve and secure with Grub Screw (Item 07)

Item	Description
01	Top Sub (2-1/2in QLS)
02	Upper Sleeve
03	Adjustable Lock Down Ring
04	Main Body
05	No-Go Key
06	Tell-tale Ring
07	Grub Screw

# GS Pulling Tools Redress

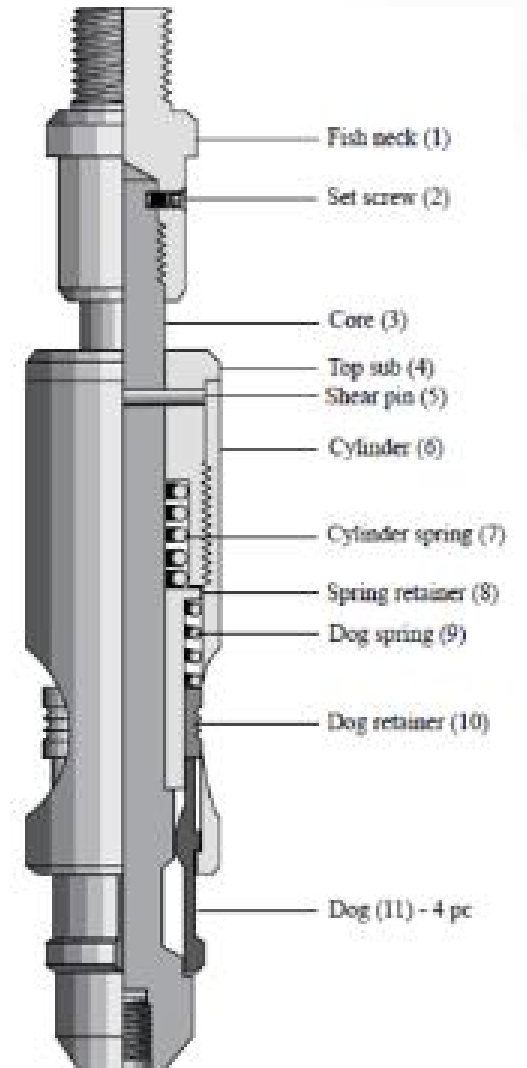
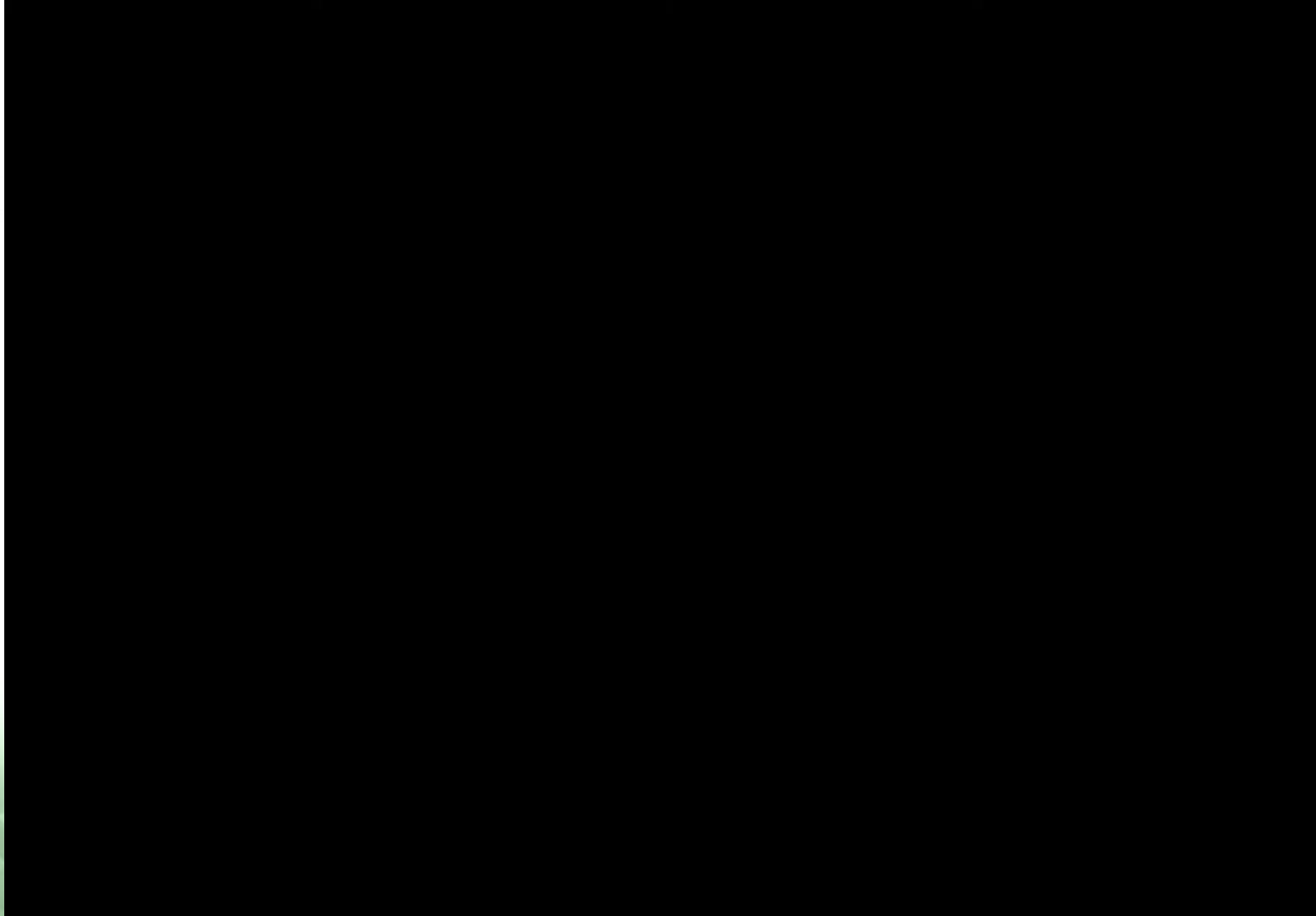

# Contingency Plan



# Operation Contingency

Event	Contingency Plan
During RIH CRQ, Toolstring unable to move down	<ul style="list-style-type: none"> <li>• RIH Wire Scratcher</li> <li>• Add More weight ( Stem )</li> </ul>
Unable to set BPV Plug at Tubing Hanger	<ul style="list-style-type: none"> <li>• RIH Wire scratcher and yo-yo at QN Profile</li> <li>• Use backup BPV at site</li> <li>• Change BPV to Sim Plug and set at desired depth</li> </ul>
GS Unable to latch Test Dart during retrieving it	<ul style="list-style-type: none"> <li>• RIH Wire Scratcher</li> <li>• Use different internal pulling tools ( PRS )</li> </ul>

# Pre and Post Operation



# Pre & Post Operational

## **Pre operational**

- Check well condition and parameter before proceed with rigging up
- Get information from EIC on well condition
- Check all Running & Pulling tools is available at location
- Ensure the BPV is in good condition before setting it up
- Ensure the grub crew & Shear pin being used during pinning the BPV is correct
- Check equipment condition & function test before start job

## **Post operational**

- Check on the BPV confirmation pin is sheared
- Record any abnormalities during RIH/POOH inside the DOR
- Rig down all equipment after job on the Well completed

Thank you