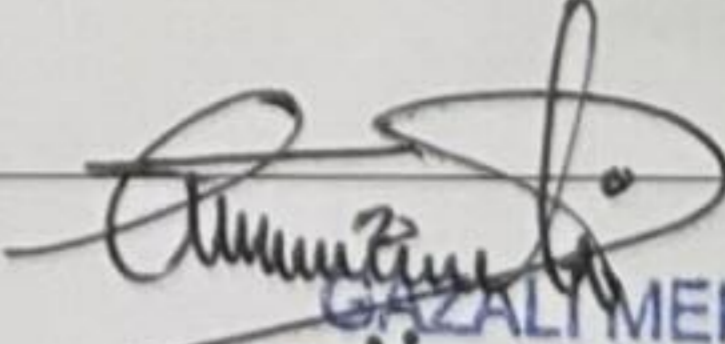

# SLICKLINE ASSISTANT WORKBOOK

**IMPORTANT NOTE:**

1. Your point of reference to complete this workbook may be obtained from the following
  - Training Manual and any other training materials provided together with this workbook
  - Your Trainer, Assessor (Slickline Operator), Verifier (FSM) or senior colleagues
  - SOP / Quality Procedures & Processors
2. The completion of this Workbook is a joint effort and responsibility between you and your assessor therefore you have the obligation to request from your assessor to be assessed upon your completion of each topic
3. The completion of this Workbook is part of the MANDATORY requirements which you must fulfill to qualify for a promotion
4. Your training program is mostly self-driven, including this Workbook. It requires individual initiatives, dedication and commitment to complete the process.

NAME	IMAN ASSHAFI BIN ROZALI
DATE OF JOIN	15 JULY 2024
CONTACT NO.	0122614358
RECEIVED DATE	21/2/25
DATE COMPLETED	21 FEBRUARY 2025

  
**GAZALI MEHRY**  
 Operation Manager  
 Dimension Bid (M) Sdn Bhd  
 Labuan Warehouse  
 Slickline Services



**B. SURFACE EQUIPMENT**

**B.1. STUFFING BOX**

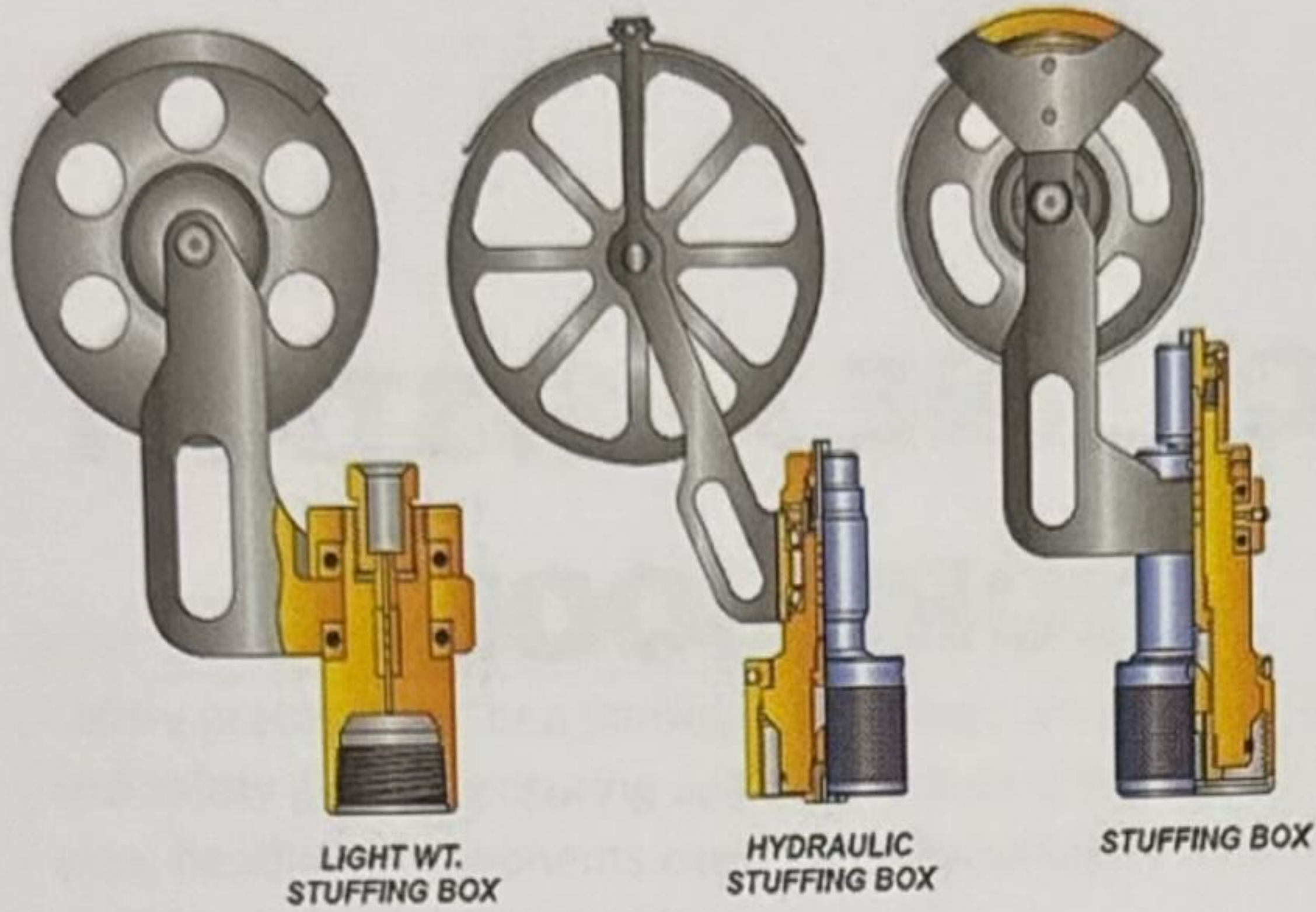

**What is Stuffing Box**

The Stuffing Box act as the primary pressure barrier, positioned at the highest point of the PCE string.

**What is the purpose of stuffing Box**

The stuffing box enables the wireline to enter the well under pressure and provides a seal in the event the wireline breaks or is blown out of the packing.

**How to operate Stuffing Box**

To operate a stuffing box, properly install it around the wireline, adjust the packing by hydraulicly tightened the nut to form a seal, monitor the pressure for leaks, and routinely inspect and replace the packing material to ensure the seal remains effective.

*(Signature)*  
**CHANDRA MEHRY**  
Operation Manager  
Dimension Bid (M) Sdn Bhd  
Labuan Warehouse  
Slickline Services



What is maintenance required for Stuffing Box

- Packings, Upper and Lower Packing Gland - Check for Wear ✓
- Sheaves - Ensure the correct size is being used ✓
- BOP Plunger – Check for wear and freedom of vertical movement ✓
- Sheave Bearings – Check for free spinning ✓
- Sheave Staff – Check for freedom of swivel movement ✓

What is safety precaution required for Stuffing Box

Safety precautions for a stuffing box include wearing appropriate PPE such as gloves and safety glasses, ensuring system pressure is within safe limits, securing the work area, handling components carefully to avoid injury, and regularly inspect packing and glands for damage and wear. ✓

What is potential hazard during handling Stuffing Box

Potential hazards during handling a stuffing box include drop objects that may result in cuts or injuries, pinch points injuries from moving parts, and back injury from improper lifting. ✓

GAZALI MEHRY  
Operation Manager  
Dimension Bid (M) Sdn Bhd  
Labuan Warehouse  
Slickline Services

21/2/25



Draw & name each part of stuffing box

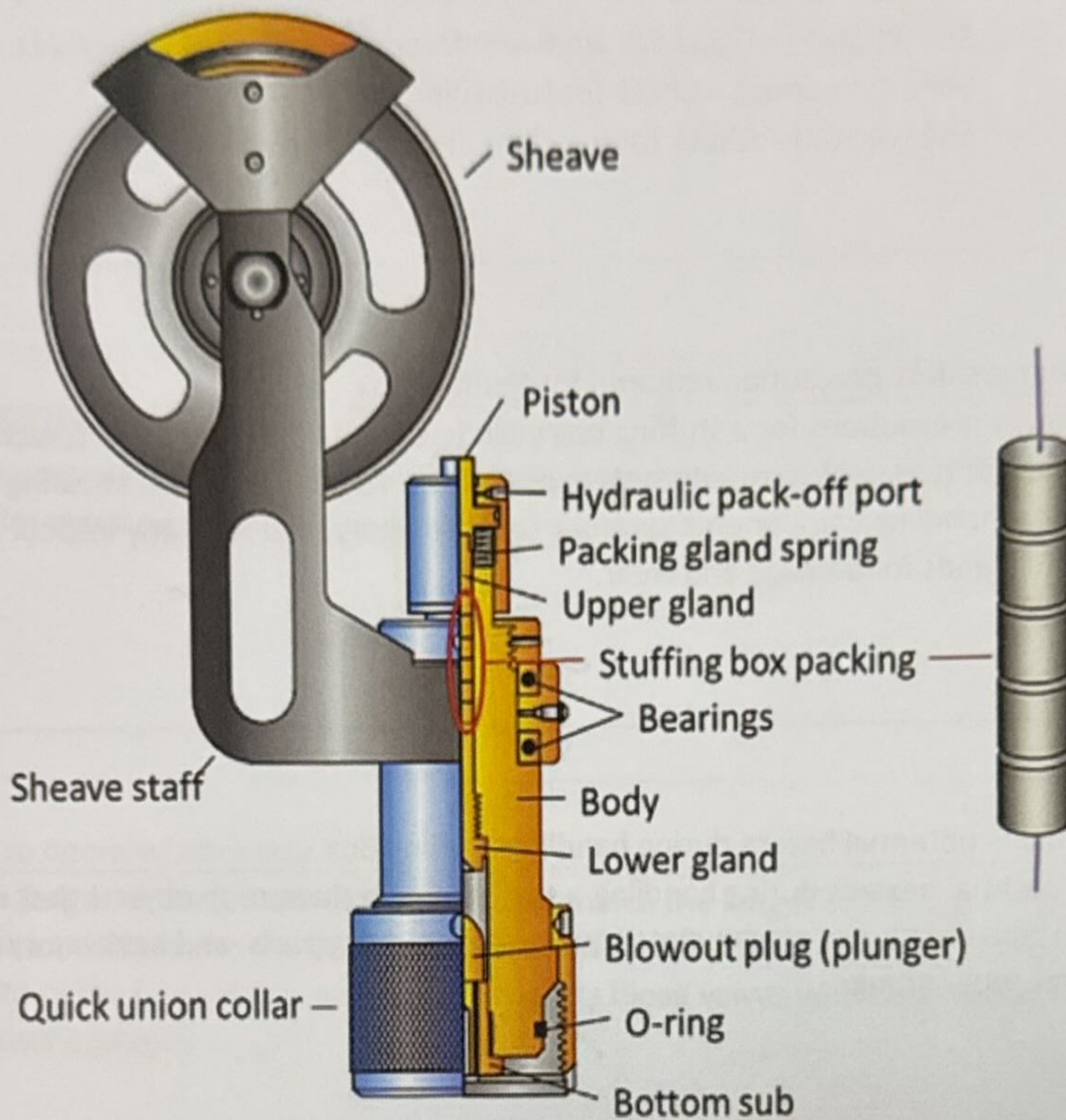

*(Signature)*  
GAZALI MEHKY  
Operation Manager  
Dimension Bid (M) Sdn Bhd  
Labuan Warehouse  
Slickline Services  
21/2/25

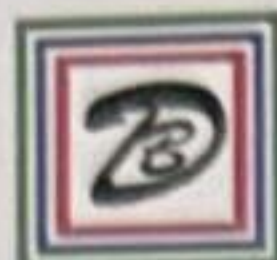

## B.2. LUBRICATOR

What is Lubricator

Lubricator, also known as riser, is a series of interconnected lengths of pipe. ✓

What is the purpose of Lubricator

The purpose of the lubricator is to provide a space for tool string to be contained under pressure, when opening and closing the wellhead. ✓

How to operate Lubricator

The length of the lubricator is designed to match the length of the tool string. It is positioned between the Stuffing Box and the Blowout Preventer (BOP). The lowest point of the lubricator is ported for attaching bleed valves with drain hoses, and pressure gauges. ✓

What is maintenance required for Lubricator

- Check for general damage and corrosion. ✓
- Redress or replace the needle valve on the lower section if necessary. ✓
- Visual inspection of the internal bore for corrosion and 'wire tracking' wear grooves. ✓

What is safety precaution required for Lubricator

Safety precautions for a lubricator, inspect the equipment for any damage or blockages, use the correct lubricant on the thread, and wear appropriate personal protective equipment, including high impact gloves and safety glasses, to avoid potential hazards. ✓

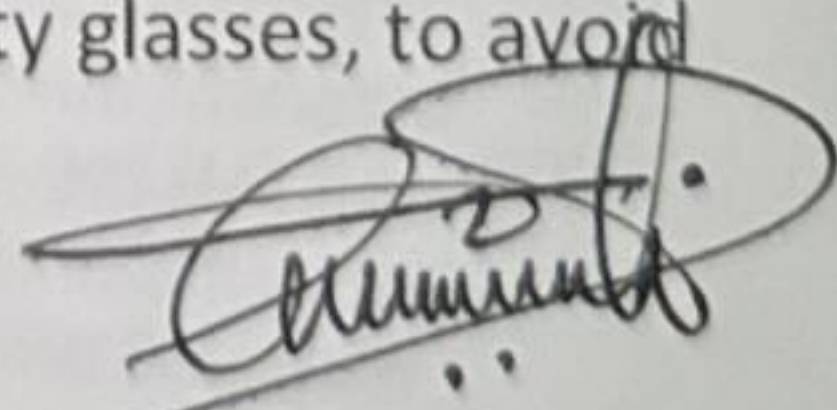
  
GAZALI MEHRY  
Operation Manager  
Dimension Bid (M) Sdn Bhd  
Labuan Warehouse  
Slickline Services

What is potential hazard during handling Lubricator

Potential hazards during handling a lubricator include drop objects that may result in cuts or injuries, pinch points injuries, and back injury from improper lifting.

Draw & name each part of Lubricator

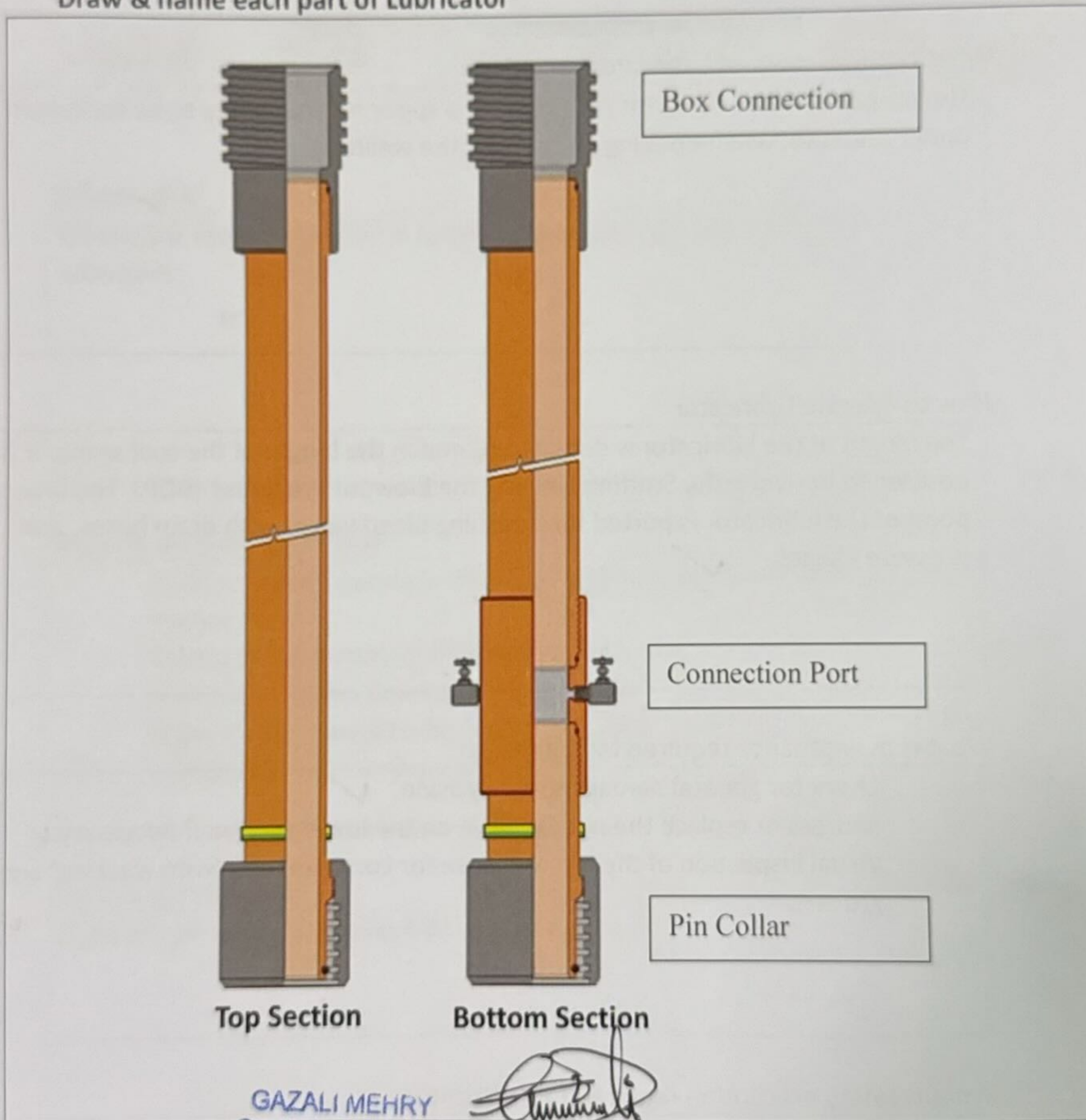

GAZALI MEHRY  
Operation Manager  
Dimension Bid (M) Sdn Bhd  
Labuan Warehouse  
Slickline Services

*[Handwritten Signature]*

5/2/18



**B.3. BLOWOUT PREVENTER (BOP)**

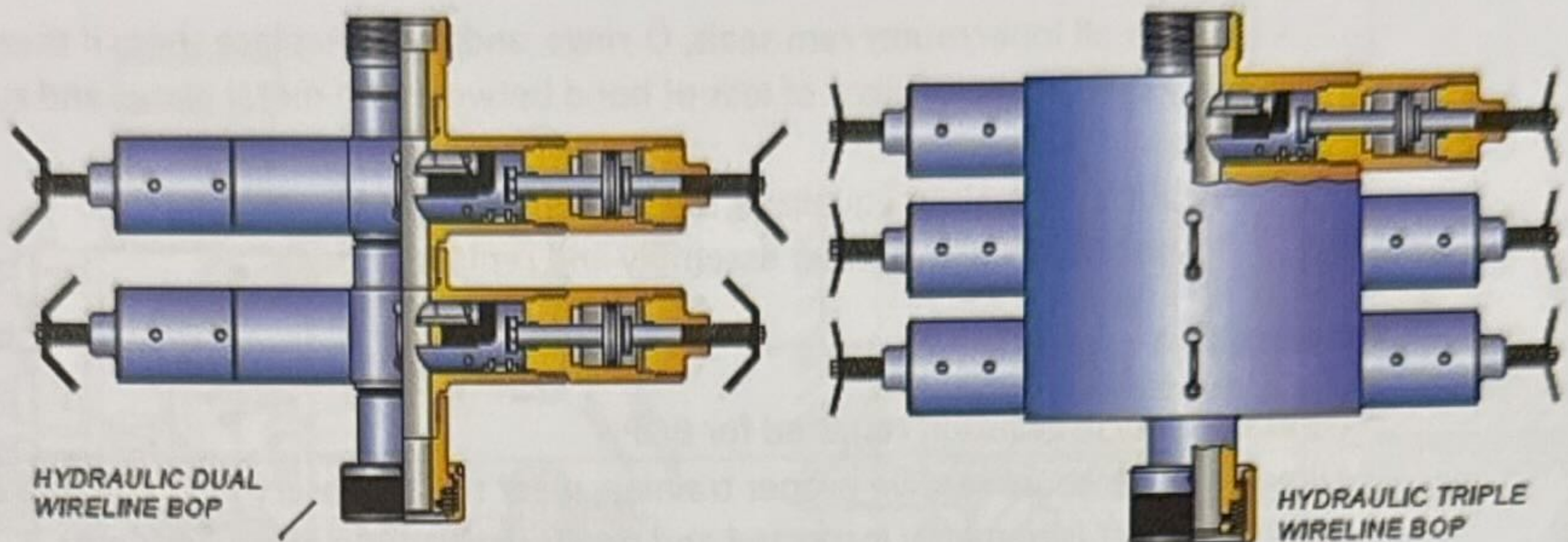

**What is BOP**  
Blown Our Preventer (BOP) is installed between the tree connection and lower lubricator.

✓

- What is the purpose of BOP**
- Enable the well pressure to isolate without cutting the wire by closing the master valve ✓
  - Permit the assembly of the wireline cutter above the BOP rams and drop it if the tool string becomes stuck in the well ✓
  - Allow slickline work to be conducted while containing well pressure on surface with wire in the wellbore. ✓

**How to operate BOP**  
Hydraulically actuated using RSU or Control Panel.

20/2/18 ✓

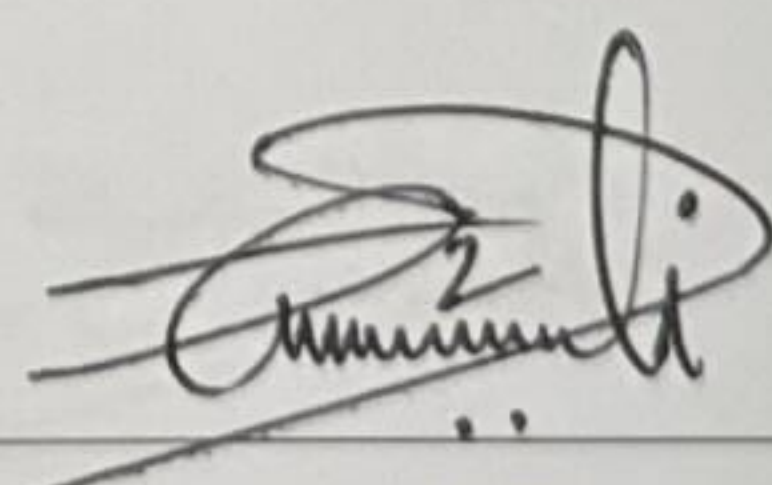
  
**GAZALI MEHRY**  
Operation Manager  
Dimension Bid (M) Sdn Bhd  
Labuan Warehouse  
Slickline Services  
21/2/25



What is maintenance required for BOP

After each job:

- Check all inner/outer ram seals, O-rings, and seals. Replace them if there are any tears, cuts, or signs of loss of bond between the metal plates and rubber.

Annually:

- Replace all seals in equalizing valve assembly.
- Inspect hydraulic cylinder assembly and replace all seals.

What is safety precaution required for BOP

All personnel should receive proper training, wear the necessary PPE, and make sure the equipment is regularly inspected and pressure tested to avoid accidents.

What is potential hazard during handling BOP

- High Pressure ✓
- Falling Objects ✓
- Personnel Injury ✓

GAZALI MEHRY  
Operation Manager  
Dimension Bid (M) Sdn Bhd  
Labuan Warehouse  
Slickline Services

21/2/25

Draw & name each part of BOP

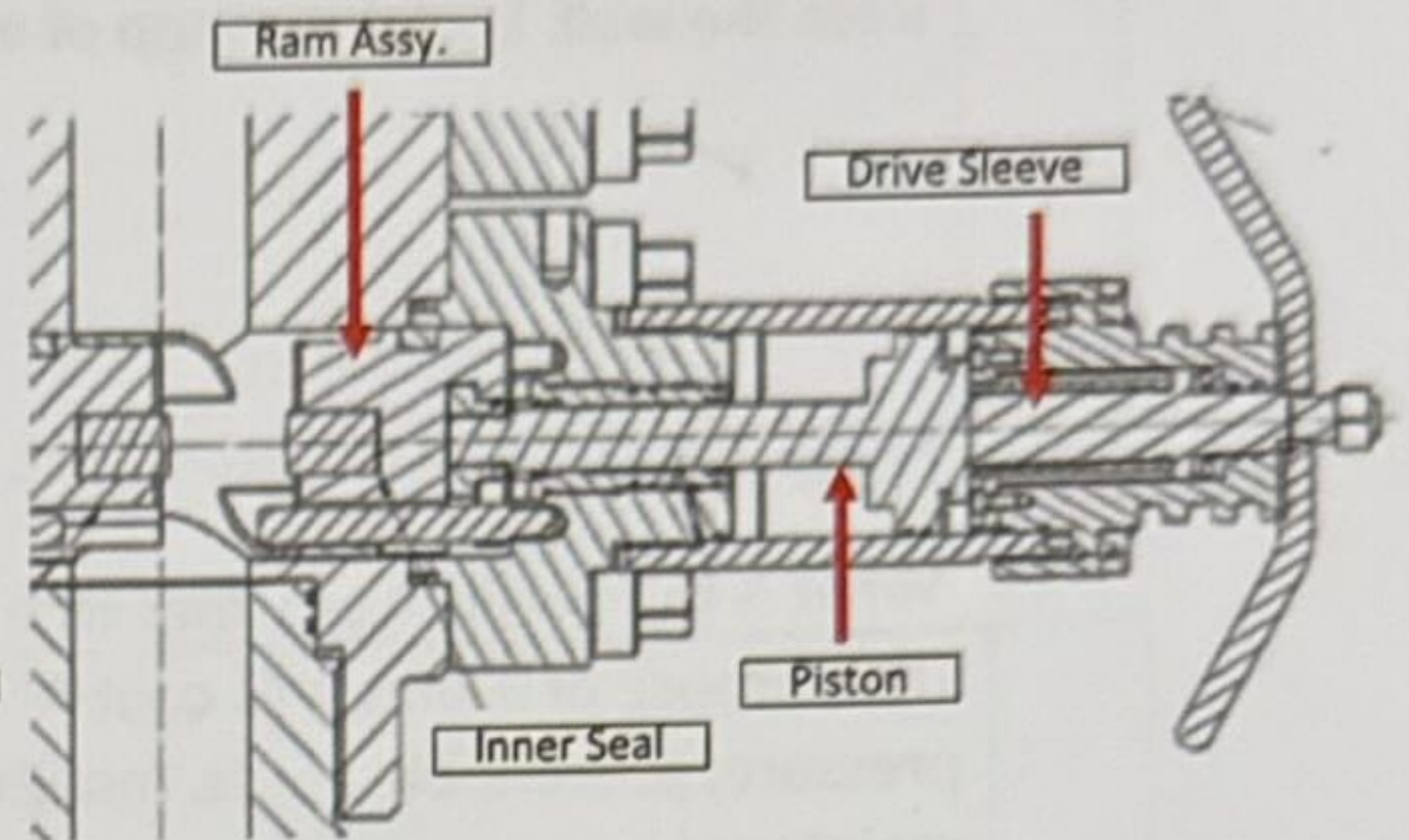
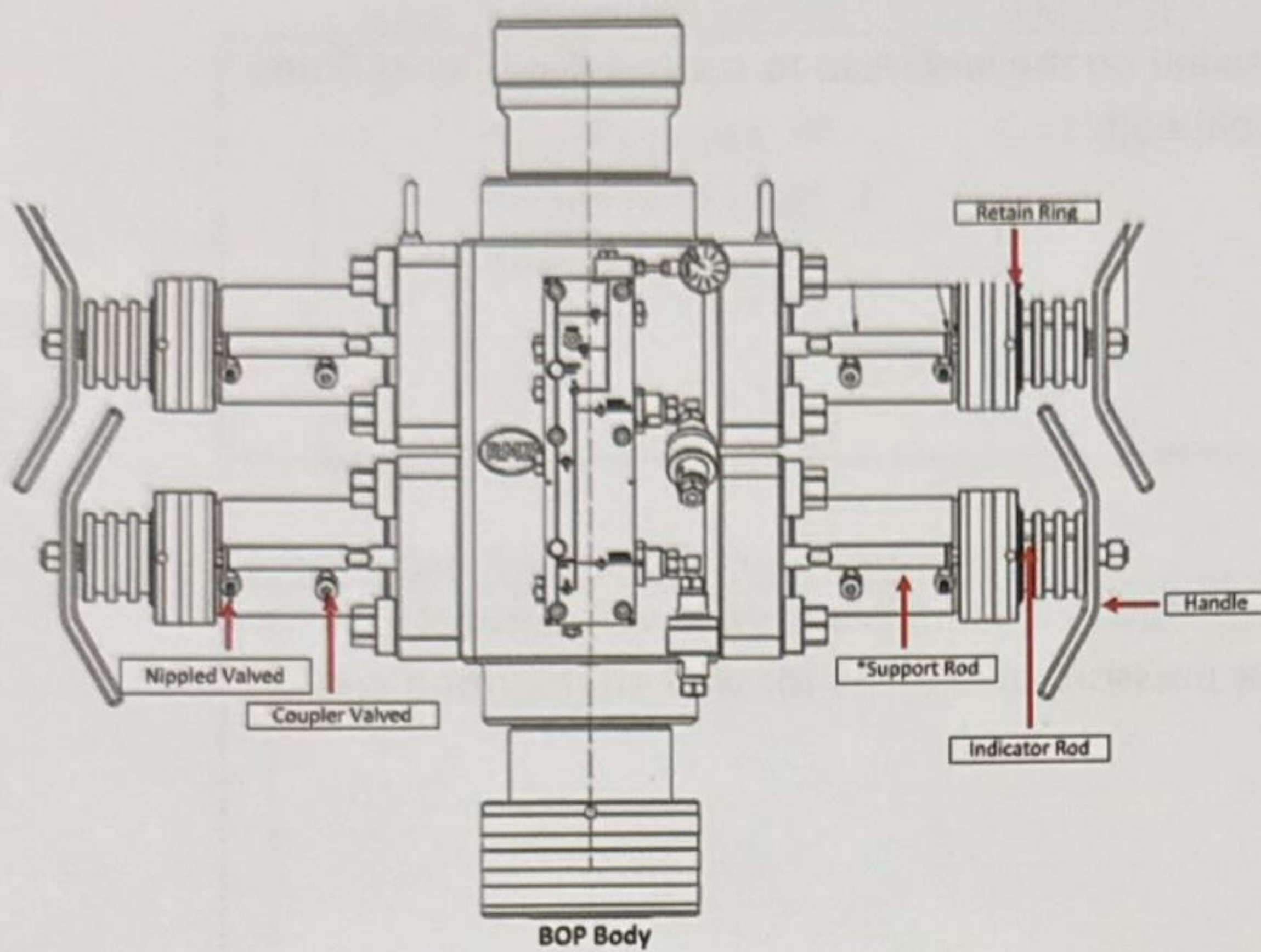

BOP Cylinder Body



Outer seal  
Inner seal

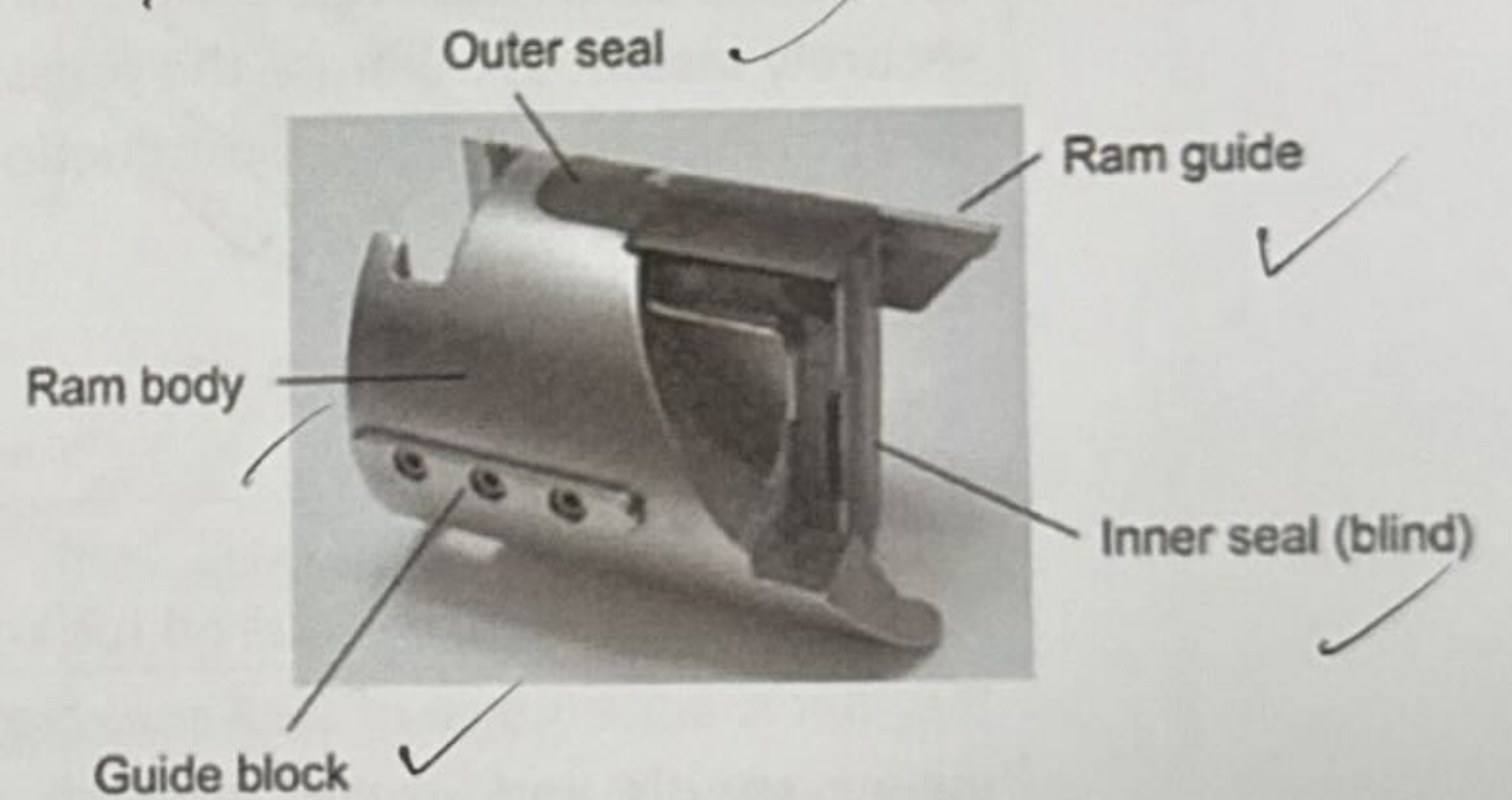

*[Handwritten Signature]*

GAZALI MEHRY  
Operation Manager  
Dimension Bid (M) Sdn Bhd  
Labuan Warehouse  
Slickline Services

21/2/25



#### B.4. X-MAS TREE

What is x-mas tree

X-mas Tree is a series of valves installed on the wellhead to control the flow of fluids from the well. Located on top of wellhead.

What is the purpose of x-mas tree

The purpose of X-mas is to control the flow of oil and gas from a well, control pressure, prevent blowouts, monitor pressure, and allow for well intervention and maintenance.

How to operate x-mas tree

To operate an X-mas Tree, ensure all components, including valves and spools, are securely installed, calibrate the pressure gauges, and then open the master valve (MV) to initiate the flow of production, while closely monitoring pressure and flow rates.

What is maintenance required for x-mas tree

Regular maintenance of an X-mas tree involves inspecting all components, including valves, spools, and fittings, for wear, corrosion, or damage, and checking seals and connections for leaks.

What is safety precaution required for x-mas tree

Count the number of turns when opening and closing the swab valve. Avoid overtightening the valves during operation and closing. Never use the master valve to shut in a flowing well, unless it's an emergency. Always use the swab or wing valve for this purpose.

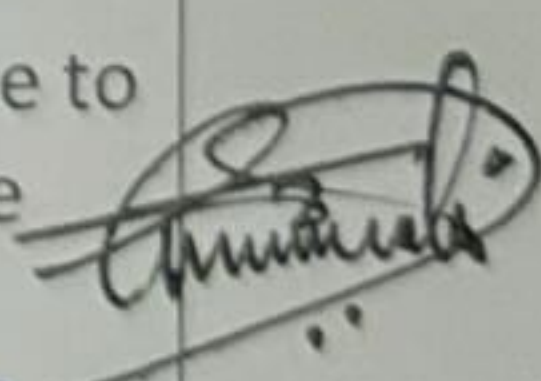
  
GAZALI MERY  
Operation Manager  
Dimension Bid (M) Sdn Bhd  
Labuan Warehouse  
Slickline Services

50/0/12

What is potential hazard during handling x-mas tree

- Pinch Point ✓
- High Pressure ✓
- Suspended Load ✓
- Line of Fire ✓

Draw & name each part of x-mas tree

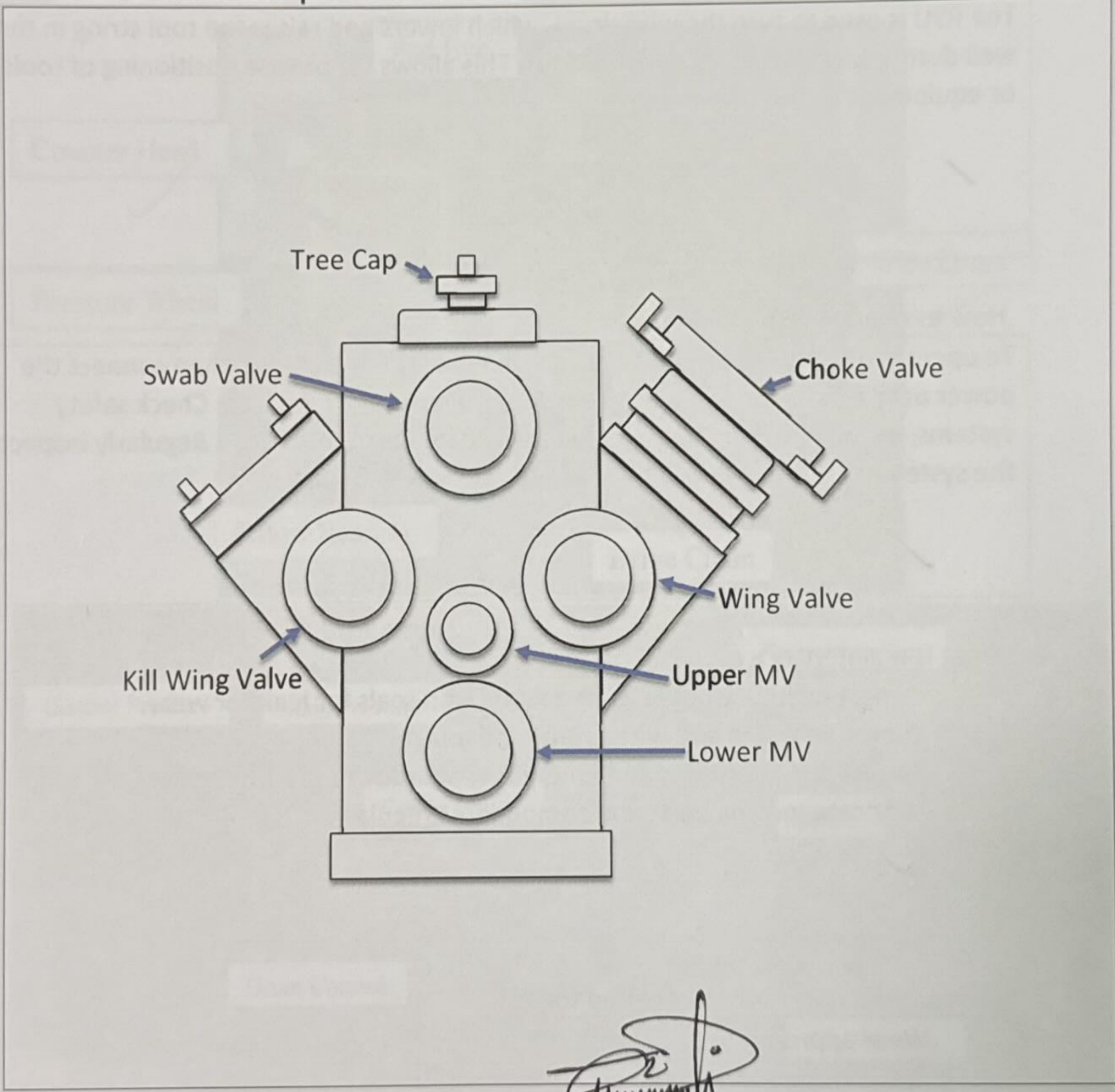

*(Signature)*  
**GAZALI MEHRY**  
 Operation Manager  
 Dimension Bid (M) Sdn Bhd  
 Labuan Warehouse  
 Slickline Services

21/2/25



### B.5. WIRELINE REEL SKID UNIT (RSU) / WINCH – SINGLE DRUM AND DOUBLE DRUM

What is RSU

RSU, also known as a wireline unit, is a piece of equipment used for running and retrieving tools or equipment in and out of well.

✓

What is the purpose of RSU

The RSU is used to turn the wire drum, which lowers and raises the tool string in the well during wireline servicing operations. This allows for precise positioning of tools or equipment within the well.

✓

How to operate RSU

To operate the RSU, position and secure the unit at the well site, then connect the power pack and hydraulic system, ensuring all hoses are leak-free. Check safety systems, including emergency shutdowns and lockout procedures. Regularly inspect the system for any issues and be ready to shut down if necessary.

✓

What is maintenance required for RSU

- Inspect hydraulic hoses, connections, and seals for leaks or wear.
- Check the winch and wire drum for damage.
- Ensure safety systems and emergency shutdowns are functional.
- Lubricate moving parts and components regularly.

✓

What is safety precaution required for RSU

- Wear appropriate PPE (helmets, gloves, safety glasses, steel-toe boots).
- Familiarize workers with emergency shutdown procedures.
- Conduct regular inspections of hydraulic systems and winch.
- Ensure clear communication during tool string operations.

✓

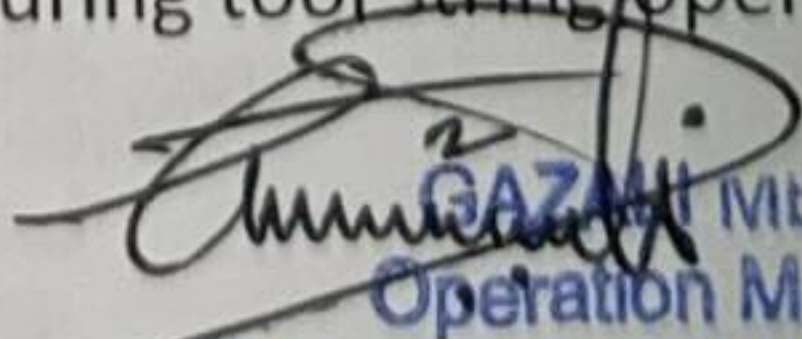
  
GAZALI MEHRY  
Operation Manager  
Dimension Bid (M) Sdn Bhd  
Labuan Warehouse  
Slickline Services

21/2/25

What is potential hazard during handling RSU

- Moving Parts ✓
- Heavy Equipment ✓
- Slips, Trips, and Falls ✓
- Personnel Injury ✓
- Pinch Point ✓

Draw & name each part of RSU

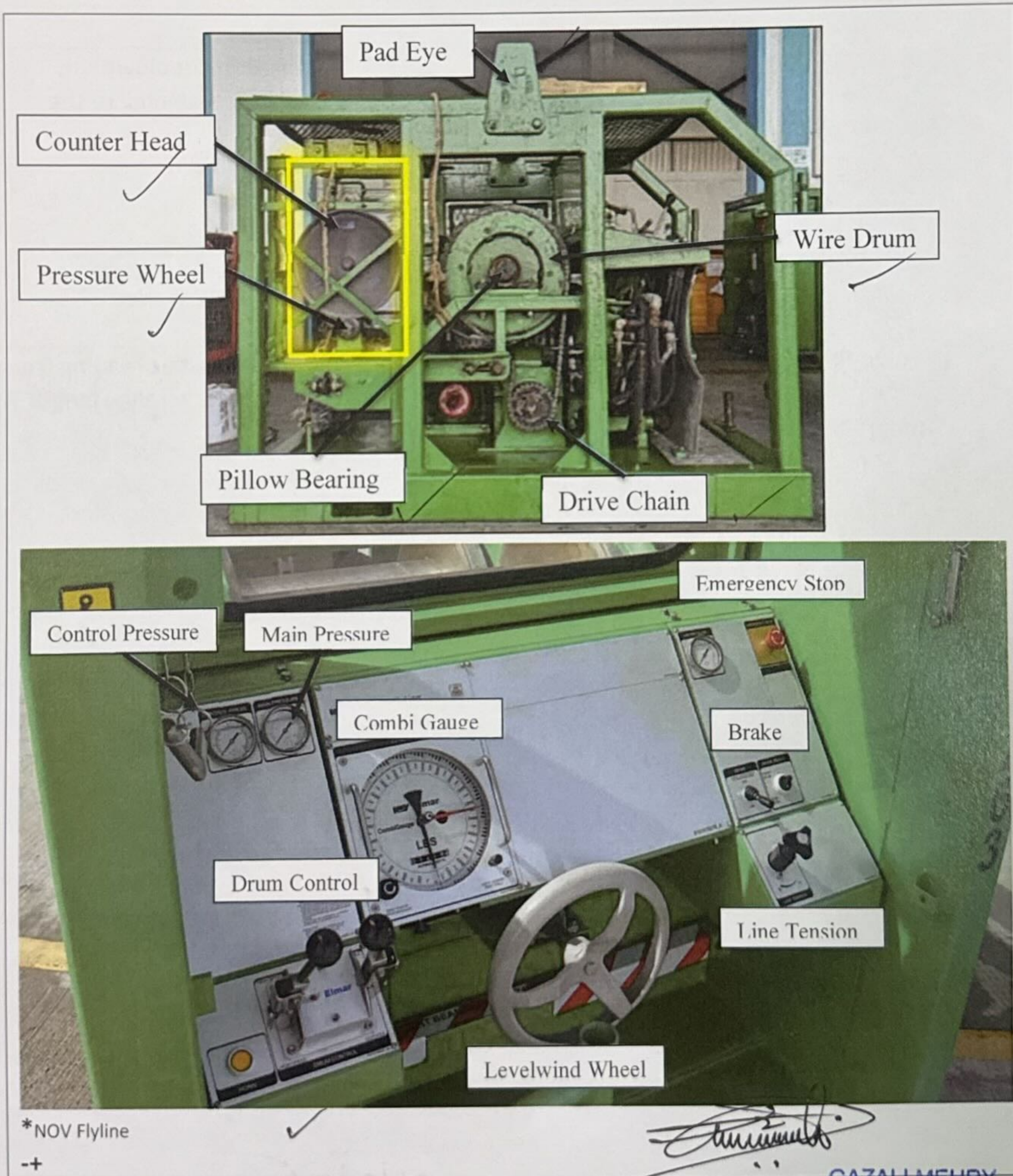

\*NOV Flyline

--+

**GAZALI MEHRY**  
Operation Manager  
Dimension Bid (M) Sdn Bhd  
Labuan Warehouse  
Slickline Services



### B.6. ODOMETER

What is Odometer

An odometer also known as Depth Counter or Depth Measuring device  
What is a device used to measure the depth traveled and track the amount of cable or wireline that has been deployed or retrieved.



What is the purpose of Odometer

It allows for precise tracking of the cable or wireline length during deployment, helping operators control the tools and avoid excessive pulling or running of the equipment.



How to operate Odometer

To operate the odometer, reset it to zero before starting the task, start reading from tubing hanger, monitor it during the operation to track distance or wireline length, and record the readings at key points for accurate tracking.



What is maintenance required for Odometer

Maintenance for an odometer includes regular calibration to ensure accuracy, cleaning to remove dirt or moisture, inspecting for physical damage, and check if counter head is free to rotate.



GAZALI MEHRY  
Operation Manager  
Dimension Bid (M) Sdn Bhd  
Labuan Warehouse  
Slickline Services

21/2/25

What is safety precaution required for Odometer

- Avoid physical impacts to prevent internal damage.
- Handle the device carefully to avoid injury from moving parts.
- Regularly check calibration for accurate readings.
- Keep the odometer clean and free from dirt, moisture, or chemicals.

What is potential hazard during handling Odometer

- Sharp Edges
- Pinch Point

Draw & name each part of Odometer

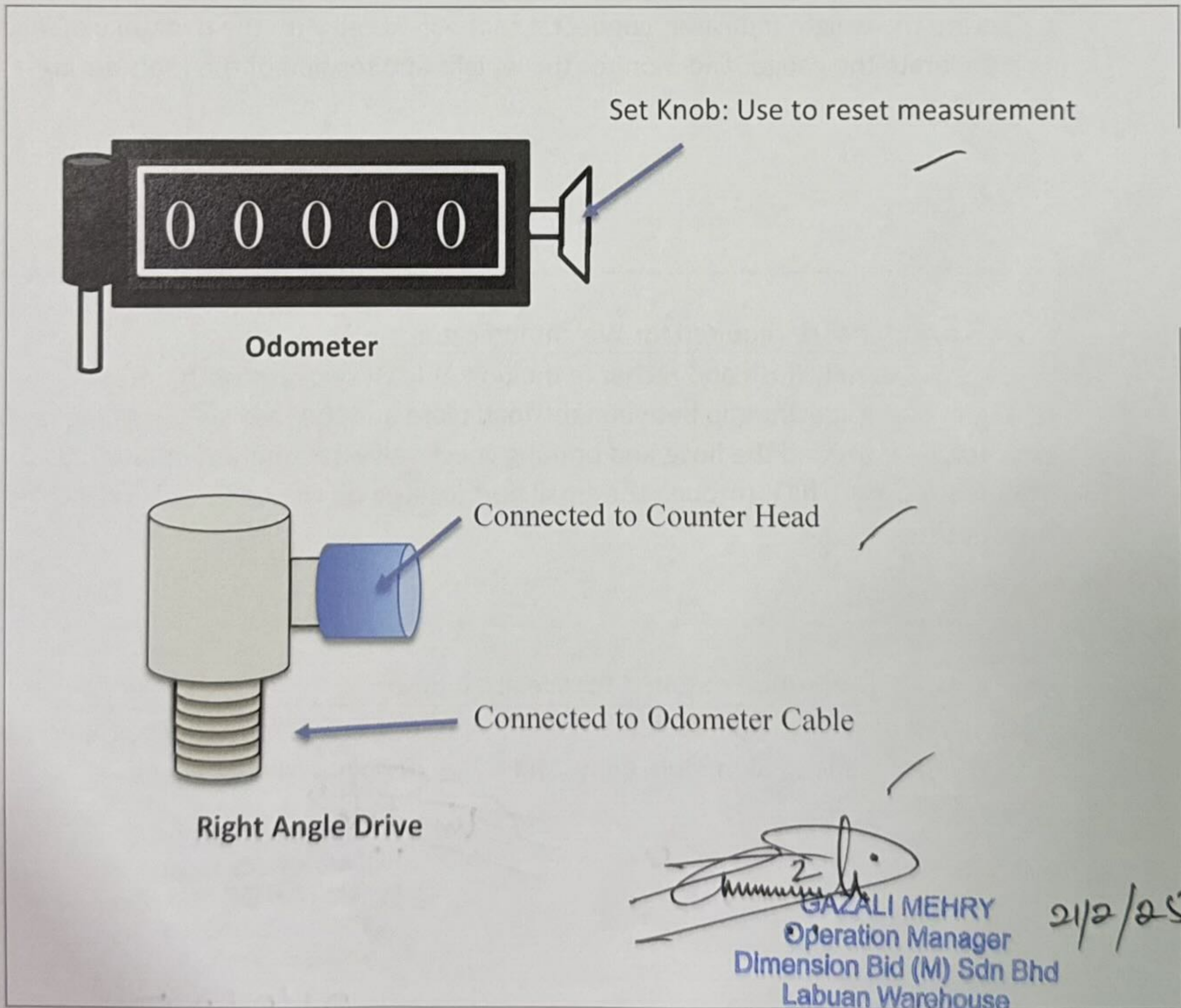

*[Signature]*  
GAZALI MEHRY  
Operation Manager  
Dimension Bid (M) Sdn Bhd  
Labuan Warehouse  
Slickline Services  
21/2/25

### B.7. WEIGHT INDICATOR (200 LBS AND 4000 LBS)

What is Weight Indicator

A weight indicator is a device used to measure the weight of tools in the tubing string. It is connected to a load cell via a rubber hose filled with hydraulic fluid, allowing the device to accurately display the weight of the tools.

What is the purpose of Weight Indicator

To measure and display the weight of tools in the tubing string during operations. It helps operators monitor the tension and weight of the equipment, ensuring proper deployment, retrieval, and positioning of tools in the wellbore.

How to operate Weight Indicator

To operate the weight indicator, connect it to the load cell with the hydraulic oil-filled hose, calibrate the gauge, and monitor the weight and tension of the tools during operations.

What is maintenance required for Weight Indicator

It is essential to fully flush and recharge the unit at least once a month. After recharging, set a specific gap between the load plate and the load cell retaining ring. Check for leaks around the hose and priming check valve assembly. If additional "W-15" fluid is needed, fill it through the small port located on the upper side of the gauge housing.

What is safety precaution required for Weight Indicator

Proper handling and do not crush the hose. Secure the gauge and fittings properly, as the load cell is made of aluminum alloy, and rough handling can damage it.

  
GAZALI MEHRY  
Operation Manager  
Dimension Bid (M) Sdn Bhd  
Labuan Warehouse  
Slickline Services

21/2/25



What is potential hazard during handling Weight Indicator

- Personnel Injury from sharp components.
- Drop Object may damage the load cell.
- Slips and Trips when hose is not secured.

Draw & name each part of Weight Indicator

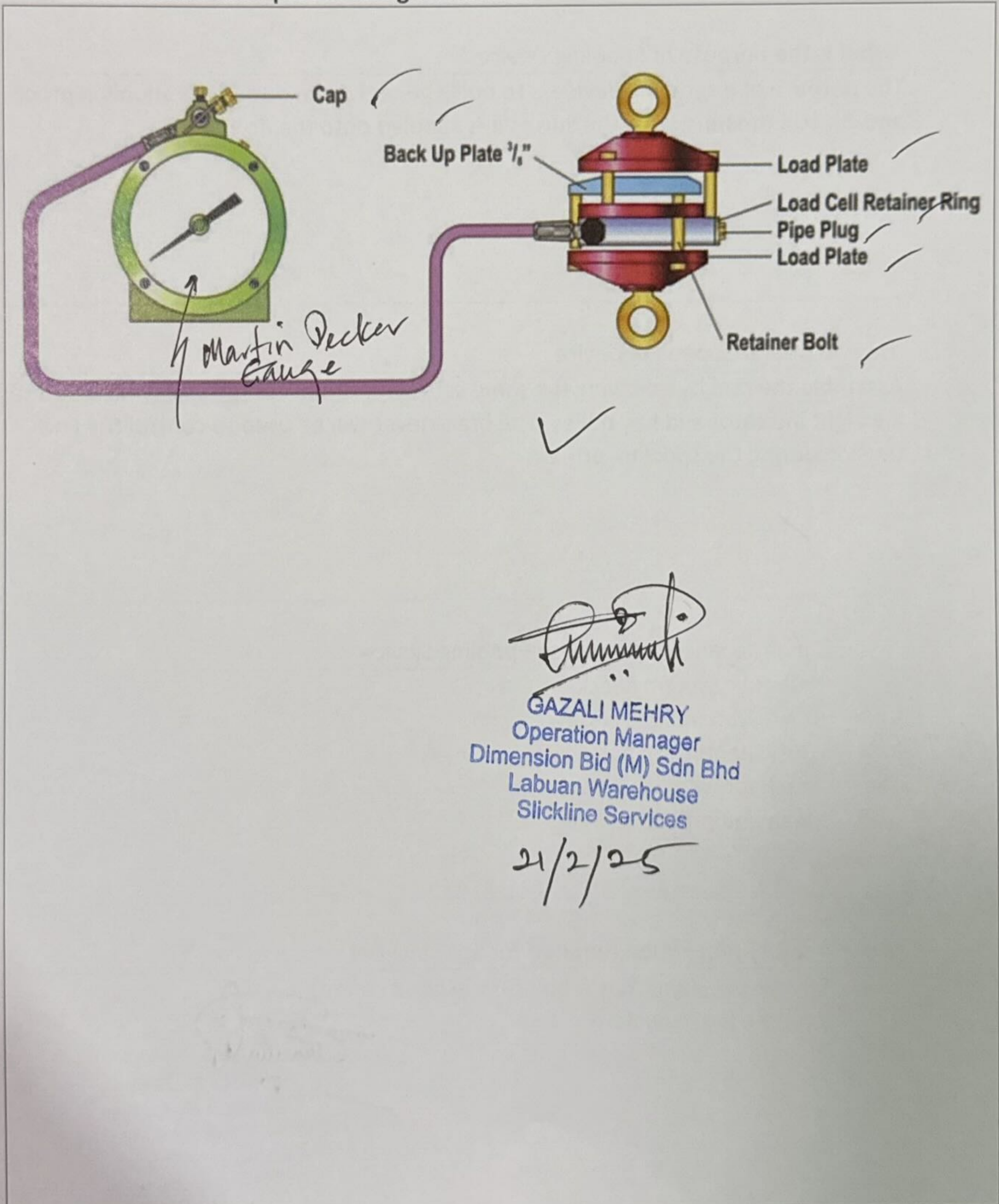

GAZALI MEHRY  
Operation Manager  
Dimension Bid (M) Sdn Bhd  
Labuan Warehouse  
Slickline Services

21/2/25

### B.8. SPOOLING DEVICE

What is Spooling Device

It is configured with a removable drum that allows transport spools to be inserted, enabling the new string to be spool onto the reel.

✓

What is the purpose of Spooling Device

The purpose of a spooling device is to hold the reel drum during the spooling process and control the tension of the line as it is spooled onto the drum.

✓

How to operate Spooling Device

Assemble the reel by following the same setup as normal operations, which requires a weight indicator and hay pulley. The brake lever will be used to control the line tension during the spooling process.

✓

What is maintenance required for Spooling Device

- ✓ - Hydraulic system check
- ✓ - Brake system Inspection
- ✓ - Lubricate moving parts
- ✓ - Check for wear
- ✓ - Clean equipment

What is safety precaution required for Spooling Device

- ✓ - Ensure bolts and nuts (Shaft) are in good condition.
- ✓ - Test the Brake System

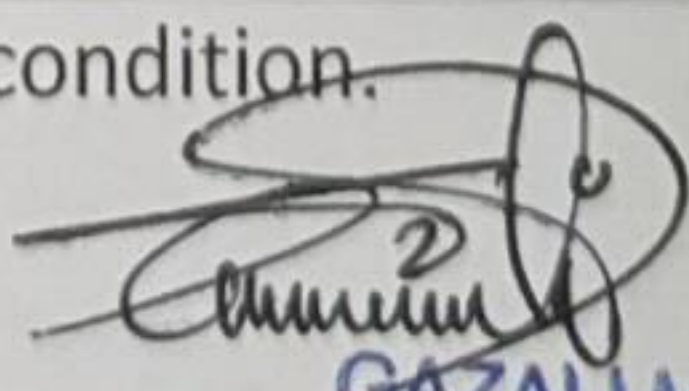
  
**GAZALI MEHRY**  
Operation Manager  
Dimension Bid (M) Sdn Bhd  
Labuan Warehouse  
Slickline Services

21/2/25



What is potential hazard during handling Spooling Device

- Pinch Point ✓
- Rotating Device ✓
- Slip, Trips and Fall ✓

Draw & name each part of Spooling Device



### B.9. CONTROL PANEL

What is Control Panel

Control panels are used to operate multiple valves typically involved in slickline operations.

What is the purpose of Control Panel

The purpose of the control panel is to operate BOP (Blowout Preventer) rams and convert low-pressure air or gas input into high-pressure oil output, ensuring proper control of well pressure and preventing blowouts during operations.

How to operate Control Panel

Function tested. Connect the control line to the equipment, open the air supply, and use the regulator to control the pump, pressurizing the line.

What is maintenance required for Control Panel

Check the fluid level of the hydraulic oil and inspect the hydraulic hoses for any signs of leakage or damage. Disassemble the air filter and clean it thoroughly every month. Annually, renew the hydraulic tank and return filters regularly, disassemble the hydraulic pump, and check for any signs of corrosion or wear.

What is safety precaution required for Control Panel

Do not tighten or loosen connections when under pressure. Always be cautious of trapped pressure and fully bleed it off before opening any connections.

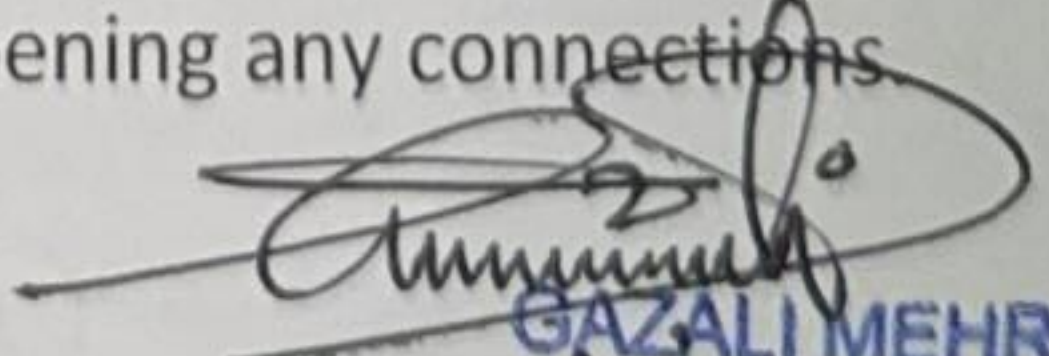
  
**GAZALI MEHRY**  
Operation Manager  
Dimension Bid (M) Sdn Bhd  
Labuan Warehouse  
Slickline Services

21/2/25



What is potential hazard during handling Control Panel

- Falls, Slips and Trips from hose and fluid leaks.
- Hose burst due to working with high pressure
- Personnel injury due to lose connections

Draw & name each part of Control Panel

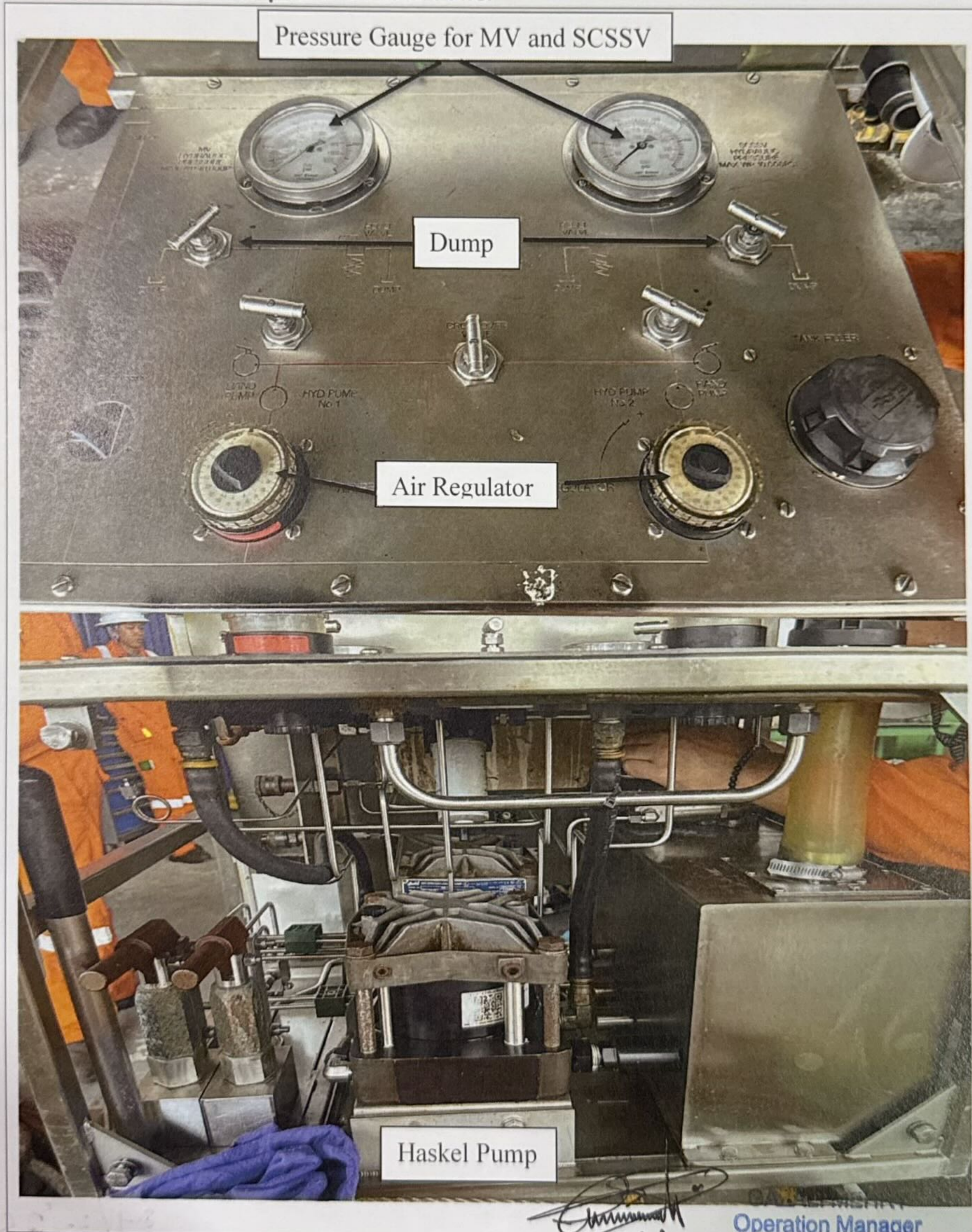

*[Signature]*  
Operation Manager  
Dimension Bid (M) Sdn Bhd  
Labuan Warehouse  
Slickline Services

**B.10. HUSKEL DRUM**

What is Huskel Drum

Is an Air Driver Pump.

✓

What is the purpose of Huskel Drum

A Huskel Drum is used to drive hydraulic or water pressure through the control panel or test pump during operations.

✓

How to operate Huskel Drum

The Huskel Drum can be operated using the knob or regulator on the control panel to adjust and manage the hydraulic or water pressure

✓

What is maintenance required for Huskel Drum

Check the condition of the O-ring, service the Haskel pump, and inspect the hydraulic check valve. Perform any necessary repairs to the liquid seal to ensure proper functioning and prevent leaks.

✓

What is safety precaution required for Huskel Drum

Check the condition of the O-ring, ensure that the connection tubing is in good condition and free of wear or damage.

✓

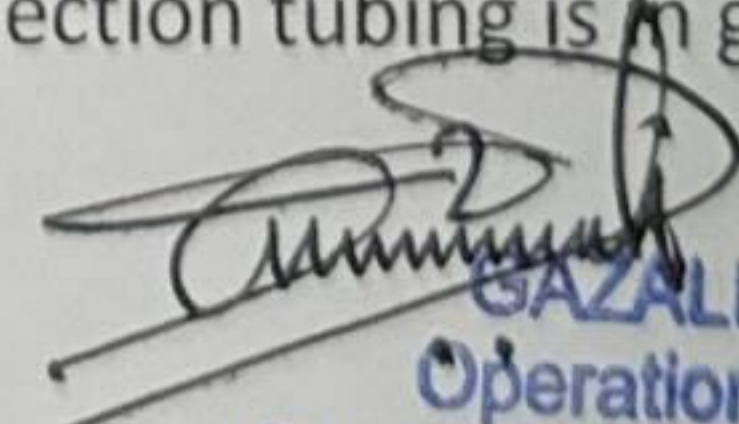
  
**GAZALI MEHRY**  
Operation Manager  
Dimension Bid (M) Sdn Bhd  
Labuan Warehouse  
Slickline Services

21/2/25

What is potential hazard during handling Huskel Drum

- Pinch Point
- Personnel Injury from tubing burst

Draw & name each part of Huskel Drum

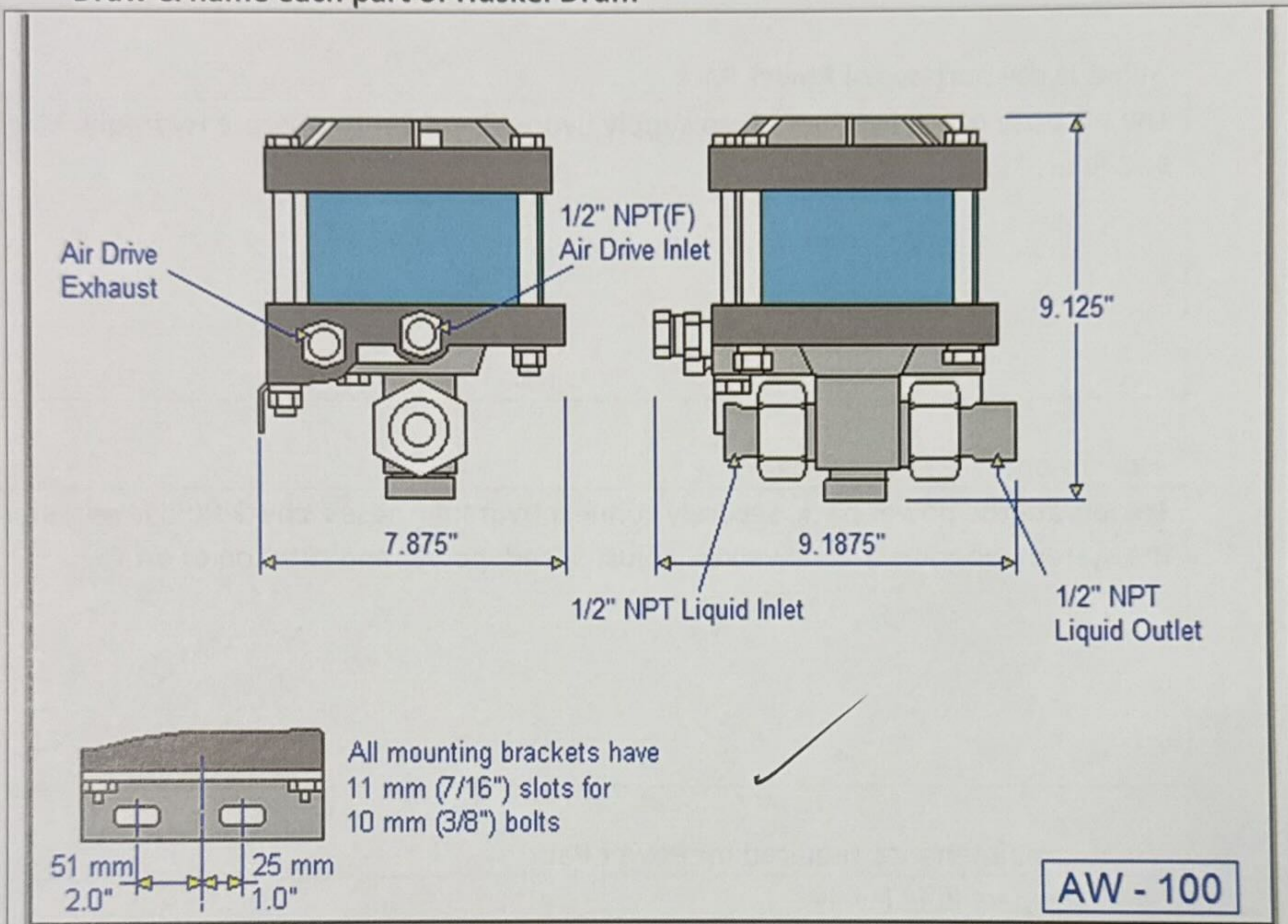

*[Handwritten Signature]*

**GAZALI MEHRY**  
Operation Manager  
Dimension Bid (M) Sdn Bhd  
Labuan Warehouse  
Slickline Services

21/2/25



### B.11. POWER PACK (ELECTRICAL & DIESEL)

What is Power Pack

The power pack is a single-piece, skid-mounted configuration with an integral crash frame. It is constructed from carbon steel and features a single-point lifting.

What is the purpose of Power Pack

The purpose of a power pack is to supply hydraulic power to operate Hydraulic Mast and Reel Skid Unit (RSU).

How to operate Power Pack

To operate the power pack, securely connect hydraulic hoses, check fluid levels, start the system, operate several valves, adjust speed, power and rotation of drum.

What is maintenance required for Power Pack

- Inspect fluid levels
- Check hoses, fittings and connections for signs of leak and wear
- Clean dirt and debris buildup

What is safety precaution required for Power Pack

Wear appropriate PPE when changing hydraulic or engine oil. Be cautious of the rotating fan when the engine is running and never open the radiator cap while the power pack is still operating to avoid burns or injury from hot coolant.

  
GAZALI MEHRY  
Operation Manager  
Dimension Bid (M) Sdn Bhd  
Labuan Warehouse  
Slickline Services

21/2/25



What is potential hazard during handling Power Pack

- Rotating Parts ✓
- Working with Pressure ✓
- Personnel Injury ✓

Draw & name each part of Power Pack

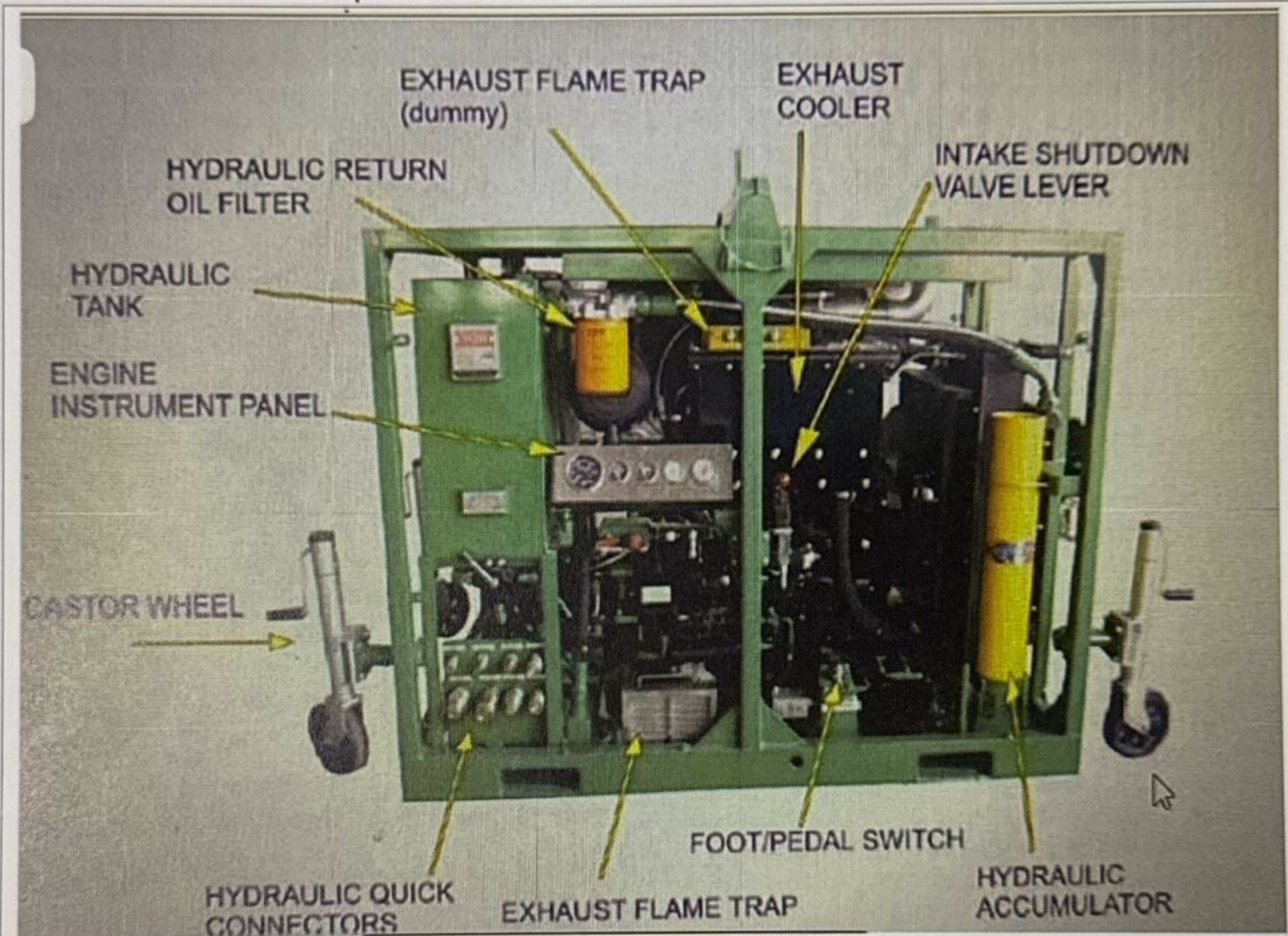

*[Handwritten Signature]*

GAZALI MEHRY  
Operation Manager  
Dimension Bid (M) Sdn Bhd  
Labuan Warehouse  
Slickline Services

*21/2/25*



**B.12. AIR COMPRESSOR**

What is Air Compressor

Air compressor is an open loop hydraulic system unit which is used to supply compressed air to Control Panels when there is no supply on site.

✓

What is the purpose of Air Compressor

To supply compressed air for control panel, test pump and air stater engine.

✓

How to operate Air Compressor

Turn on the compressor using the start switch and allow it to build up pressure. To crank the starter, rotate the shaft clockwise until the indicator turns red. Once this is done, replace the spring to fully engage and start the engine.

✓

What is maintenance required for Air Compressor

- Oil Change ✓
- Air Filter Change ✓
- Inspect Belt Condition ✓

What is safety precaution required for Air Compressor

Ensure all hose connections are secure and free from leaks. Also, verify that the fan is properly covered to prevent accidental contact with moving parts. ✓

*[Signature]*  
**GAZALI MEHRY**  
Operation Manager  
Dimension Bid (M) Sdn Bhd  
Labuan Warehouse  
Slickline Services

21/2/25



What is potential hazard during handling Air Compressor

- High Pressure Air
- Moving Parts
- Noise
- Slips and Fall
- Pinch Point

Draw & name each part of Air Compressor

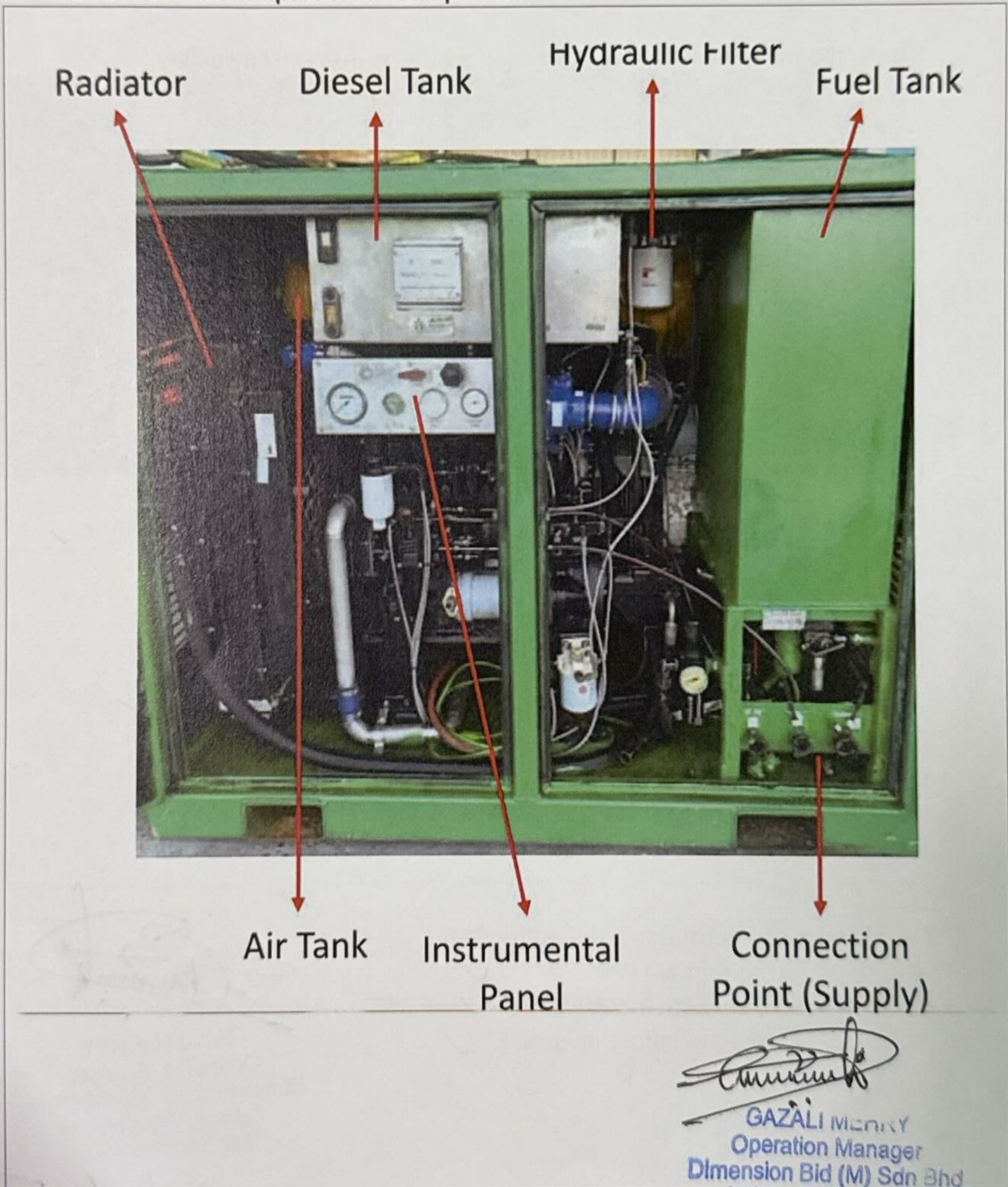

*[Signature]*  
GAZALI MERRY  
Operation Manager  
Dimension Bid (M) Sdn Bhd  
Labuan Warehouse  
Slickline Services

21/2/25

**B.13. DRUM**

What is the purpose of Drum

To spool the wireline wire.

Draw the right and wrong wire arrangement from drum to hay pulley

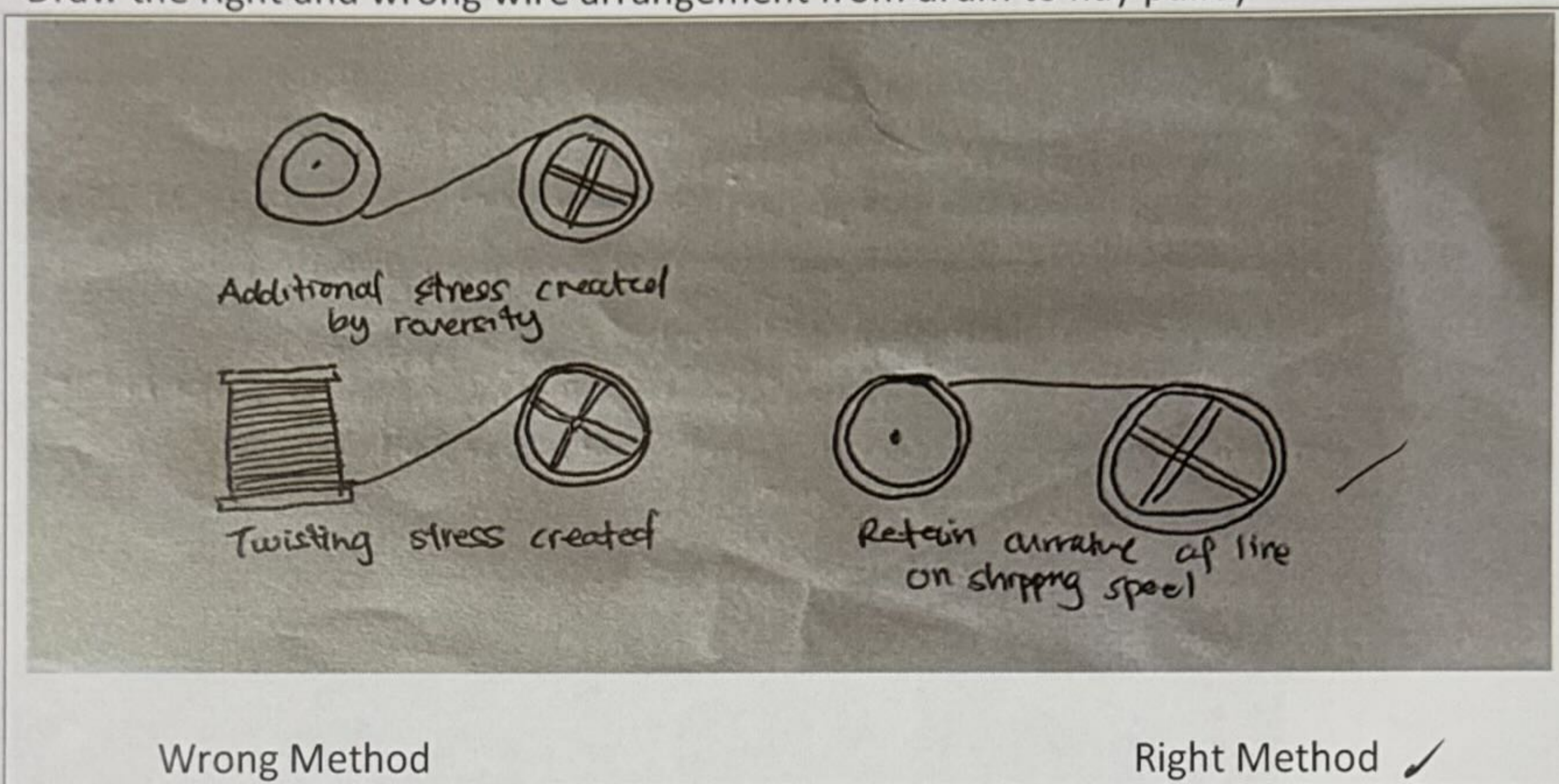

What is maintenance required for Drum

- Service & lubricate drum bearings ✓
- Change the drum if cracks, dents and sign of wear are found ✓

What is safety precaution required for Drum

- Wear appropriate PPE ✓
- Be cautious with moving parts ✓
- Secured drum before operation ✓

*[Signature]*  
**GAZALI MEHRY**  
Operation Manager  
Dimension Bid (M) Sdn Bhd  
Labuan Warehouse  
Slickline Services

*[Signature]*



What is potential hazard during handling Drum

- Pinch Point ✓
- Falling Objects ✓
- Rotating Device ✓
- Back Injury ✓

Please draw/sketch the toolstring configuration for:

- 1) Drift run/tubing clearance check ✓
- 2) Sinker bar run ✓
- 3) Set and retrieve plug ✓
- 4) Set and retrieve insert valve ✓

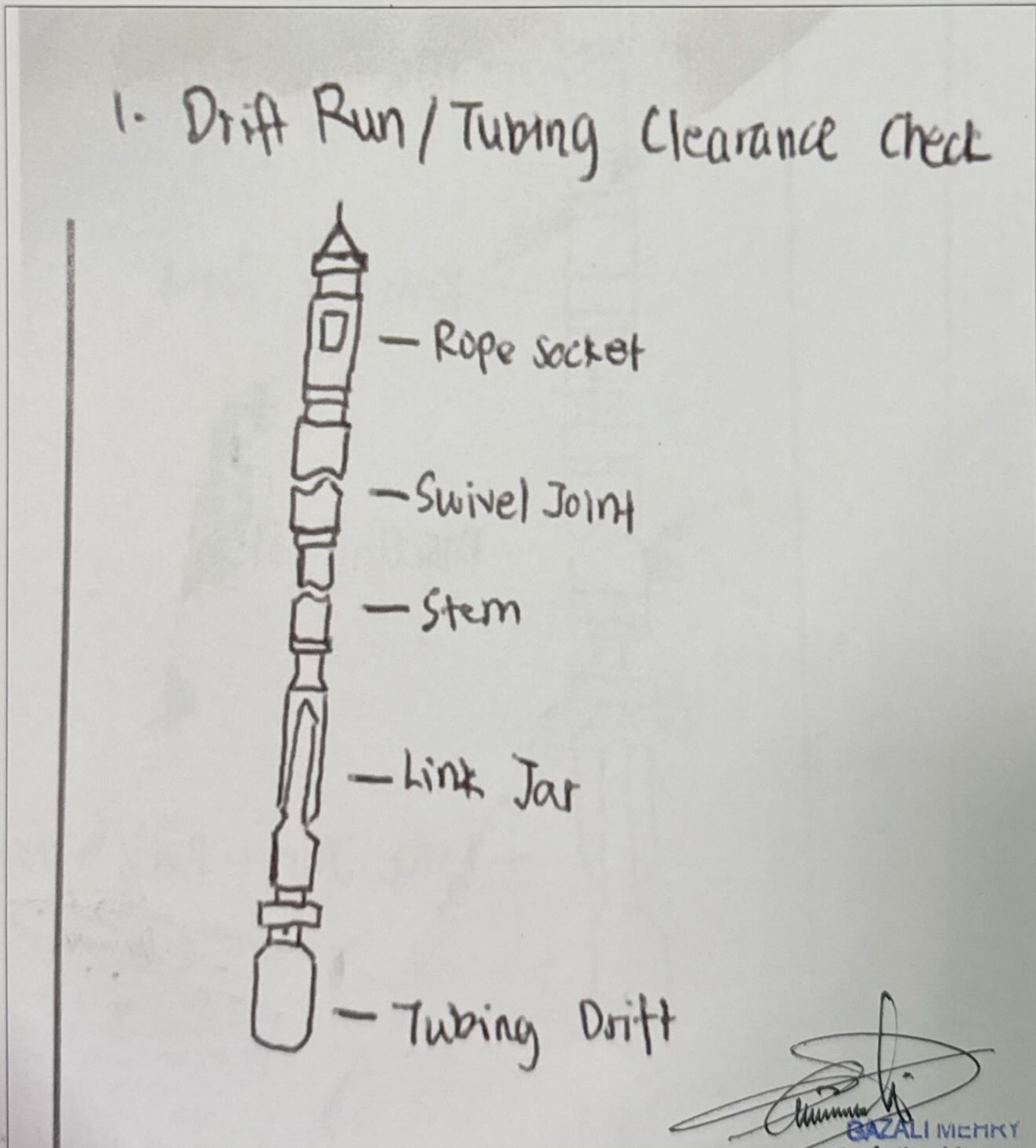

*[Signature]*  
GAZALI MERRY

Operation Manager  
Dimension Bid (M) Sdn Bhd  
Labuan Warehouse  
Slickline Services

*[Handwritten initials]*



## 2. Sinker Bar Run

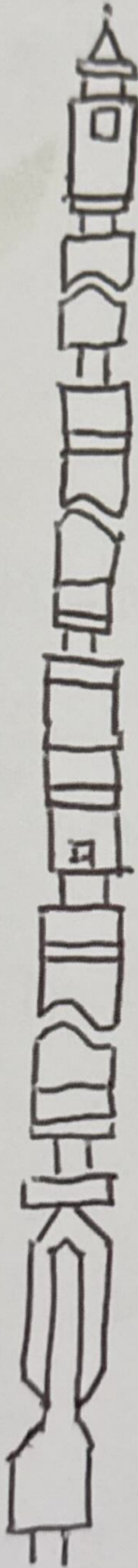

- Rope Socket

- Swivel Joint

- Malleable Stem

- Knuckle Joint

- Malleable Stem

- Link Jar + Ball Nose

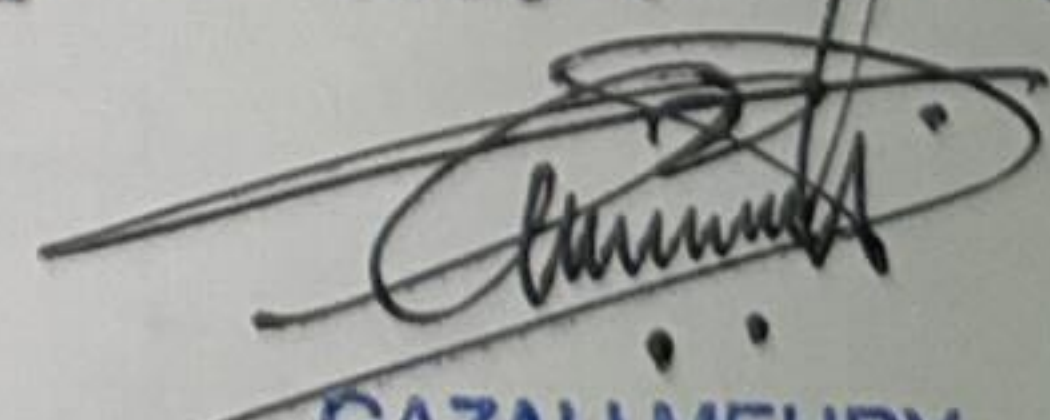
  
GAZALI MEHRY  
Operation Manager  
Dimension Bid (M) Sdn Bhd  
Labuan Warehouse  
Slickline Services

2/2/25



### 3. Set/Retrieve Plug

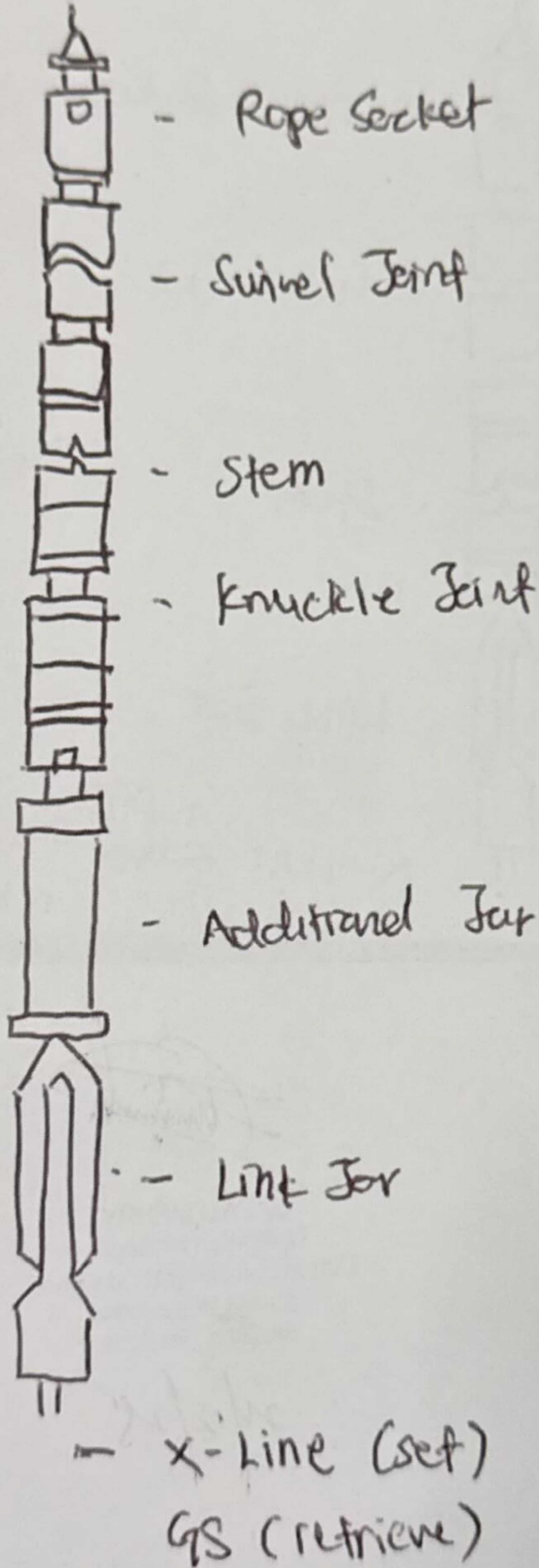

*[Signature]*  
GAZALI MEHRY  
Operations Manager  
Dimension Bid (M) Sdn Bhd  
Labuan Warehouse  
Slickline Services



#### 4. Set/Retrieve Insert Valve



- Rope Socket

- Barrel Joint

- Stem

- Link Jar

- ~~X-Line~~ + Prong (set)  
- GSL + Prong (retrieve)

GAZALI MEHRY  
Operation Manager  
Dimension Bid (M) Sdn Bhd  
Labuan Warehouse  
Slickline Services