



TRAINEE ASSESMENT

NAME : MUHAMMAD HASNAWI BIN SUDARSO

DATE : 23 May 2023

CONTENT

- PERSONAL PROTECTIVE EQUIPMENT
- INTRODUCTION TO SLICKLINE
- SURFACE EQUIPMENT (SE)
- PRESSURE CONTROL EQUIPMENT (PCE)
- DOWNHOLE TOOLS (DHT)

PERSONAL PROTECTIVE EQUIPMENT (PPE)

- Personal Protective Equipment (PPE) is essentially a range of items you can wear that will protect you against various hazardous conditions. PPE is important because **it prepares you for health and safety risks and gives you extra protection in the event of an accident or against the elements.**
- As a last barrier protection at workplace
- It is referred to as PPE that equipment worn to minimize exposure to hazards that cause serious workplace injuries and illnesses



INTRODUCTION

WHAT IS SLICKLINE ?

- SINGLE STRAND WIRE IS USED TO RUN TOOLS INTO WELLBORE FOR SEVERAL PURPOSES
- TYPE OF SERVICE :
 - 1 . ROUTINE JOB
 - 2 . NON ROUTINE JOB



SURFACE EQUIPMENT (SE)

POWER PACK
REEL SKID UNIT
HAY PULLEY
WIRE TESTER
WEIGHT INDICATOR
ODOMETER
WIRELINE MAST
COMPRESSOR

HAZARDOUS AREA

Zone 0	Explosive atmosphere is CONTINUOUSLY present
Zone 1	Explosive atmosphere is OFTEN present
Zone 2	Explosive atmosphere is ACCIDENTALLY present

- Zone 0: An area in which an explosive gas atmosphere is present continuously or for long periods
- Zone 1: An area in which an explosive gas atmosphere is likely to occur in normal operation. a place in which an explosive atmosphere consisting of a mixture with air or flammable substances in the form of gas, vapour or mist is likely to occur in normal operation occasionally.
- Zone 2: An area in which an explosive gas atmosphere is not likely to occur in normal operation and, if it occurs, will only exist for a short time

POWER PACK

- Open loop hydraulic system which are used to power up RSU and Wireline Mast.
- These Power pack uses diesel engine to produce power.
- The connection are used in power packs are Holmbury & Snaptite type connection
- This Power pack certificate in zone 2

Safety shutdown system	Set at
Overspeed shutdown	2200 rpm
Low engine oil pressure	15 PSI
High coolant temperature	99 deg Celsius
High exhaust temperature	200 deg Celsius

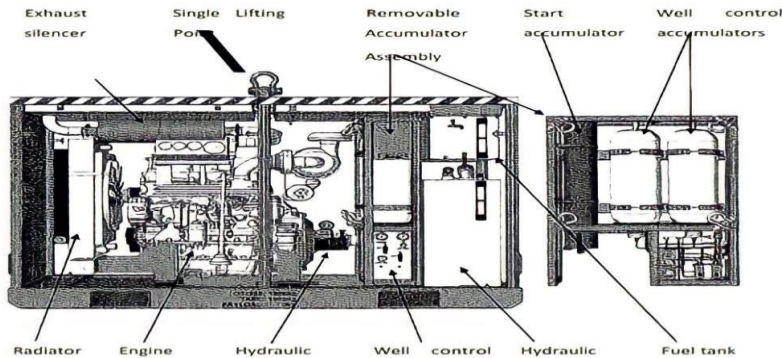

HOW TO START PP (SOP)

1) Sentinel valve



2) Hand pump



3) Intake shutdown valve



4) Pedal start switch



HOW TO START PP(FLYLINE)

1) Sentinel valve



2) Winding nut



3) Air inlet Valve



4) Spring tip lever



REEL SKID UNIT (RSU)

- Known as **wireline unit** or **winch** it used to conveys downhole equipment in and out of the wells
- Depth and tension measurement using odometer and weight indicator
- Hydraulic power by power pack which provide flow and pressure to hydraulic drum motor which can fit with one or two wireline drum.



Main pressure gauge ,
control pressure gauge
, air pressure gauge

Open/close
ram

Drum wire

Measuring/counter
wheel



odometer

brake

Steering

Gear

Drum speed
control



Pressure wheel

Brake pad drum

Right angle drive

HAY PULLEY

- To bring wireline drum from stuffing box and into horizontal to the wireline winch drum
- The wire should form 90 degree angle at the pulley
- This 90 degree angle is important to provide an accurate reading of line tension on the weight indicator
- Hooked directly on to the eye of weight indicator/load cell

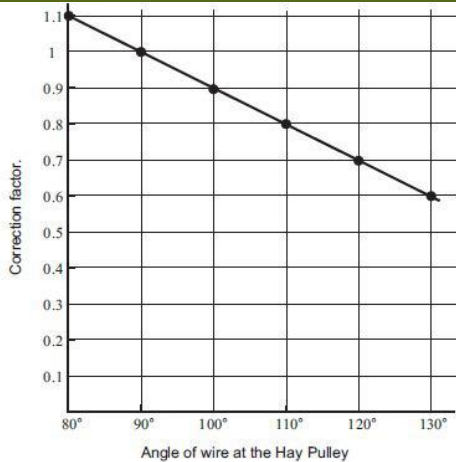

The correction factor is applied to the indicated weight to obtain true weight on the wire.

eg: With a wire angle at the hay pulley of 120° the weight indicator reads 800 kg. What is the true line force?

Ft (force on the wire)	=	800 kg
Correction factor for 120°	=	0.7
$800 \div 0.7$	=	1143
Actual line force	=	1143 kg



WIRE TESTER

- To determine condition of the wire
- Result will be recorded at chart recorder in lbs
- Suitable for ZERON 100hs



ZERON 100 HS STAINLESS STEEL WIRE

Z E R O N 1 0 0 H S S T A I N L E S S S T E E L W I R E

Diameter (Inch)	Minimum Breaking Load (lbs)	Minimum Torsion	Safe Working Pressure@60%
0.092"	1920	4	1152
0.108"	2500	3	1500
0.125"	3300	2	1980
0.140"	4050	2	2430

WEIGHT INDICATOR

- To allow the total weight of the tool string hung at the end of the wire to be read and reflected by weight indicator.
- Available in 2000lbs , 4000lbs , 5000lbs



ODOMETER

- Known as depth counter or depth indicator
- Use for measuring depth wireline tool string depth in the hole in feet or meters.
- Five digits meter reading and manual zero rest. Connected to counter head.



Y PUMP & FLUID

- Y pump use for pumped w15 fluid in load cell & hose load cell
- W15 fluid for load cell



WIRELINE MAST

- To lift or hanging lubricator during operation (rig up)
- Available at 30FT , 40 FT , 70FT
- 70ft zone 1
- This equipment is used if there is no gin pole or crane available on site.



AIR COMPRESSOR

- Open loop system unit to supply compressed air to CP,PTU and SWCP. Used diesel engine to produce power.
- The connection used Chicago type connection.
- Oil compressor by using RARUS 427.
- Air supply is 100 to 130 psi.



PRESSURE CONTROL EQUIPMENT

QUICK UNION
STUFFING BOX
LUBRICATOR
QUICK TEST SUB
BLOWOUT PREVENTER
BALL VALVE
PUMP IN TEE
CROSSOVER
CONTROL PANEL
PRESSURE TEST UNIT
LOW TORQUE VALVE
ACCESSORIES

QUICK UNION

- Connection that use for assembly Slickline of PCE
- Otis type connection – 45 degree
- Bowen type connection – 90 degree
- Difference between Otis and Bowen are external holes, internal angle and pin diameter
- Working pressure – 5000 psi to 15000psi

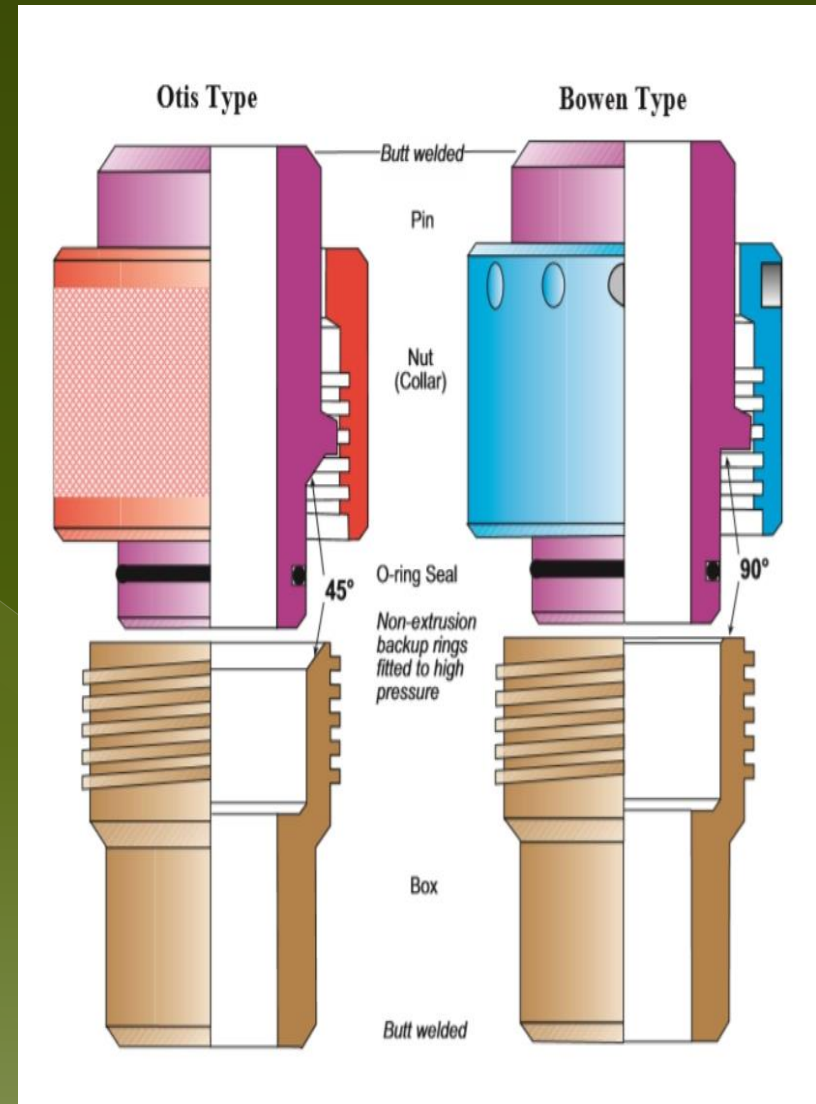

STUFFING BOX

- Allows the wireline to enter the well under pressure and provide a seal should be wireline break and be blow out of packing. Is a primary pressure barrier
- Can catch the wire if the wire suddenly snaps in the hole. BOP plunger force up by well pressure and seal against lower gland to seal pressure
- Positioned at the uppermost point of the PCE string
- Sheave diameter 16" , 18" , 20"
- Guides the wire from the bottom hay pulley into the top of the lubricator rig up
- Brass internal components prevent slickline damage
- Working pressure – 5000 psi to 15000 psi

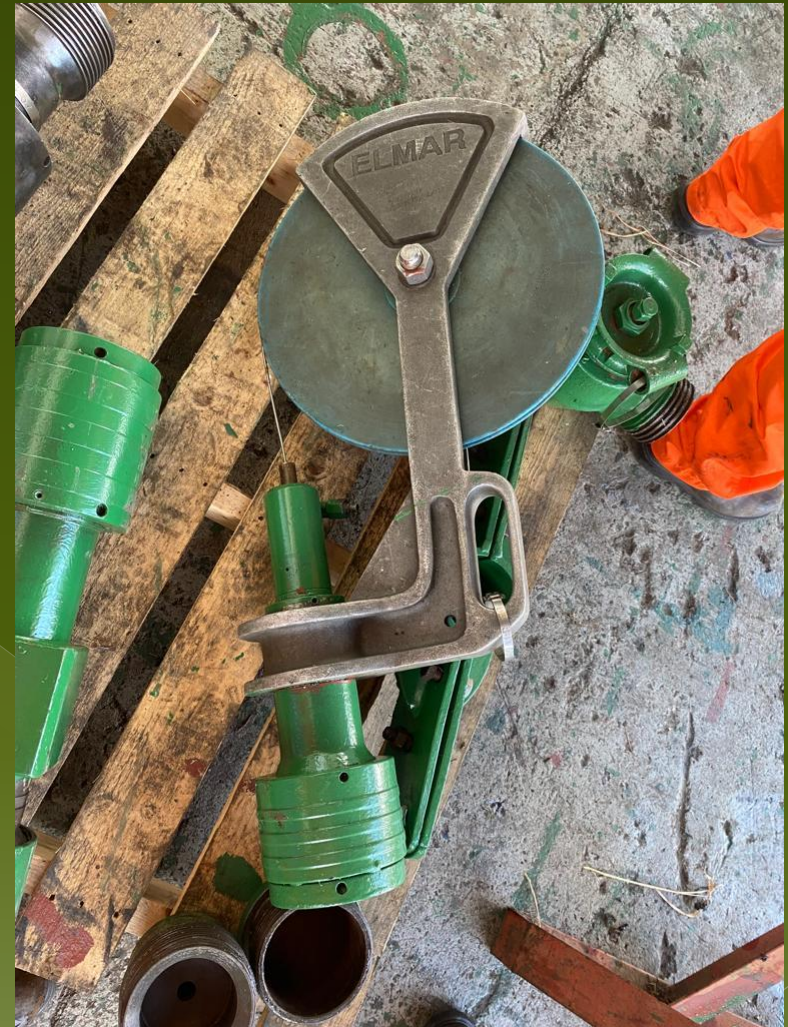

STUFFING BOX

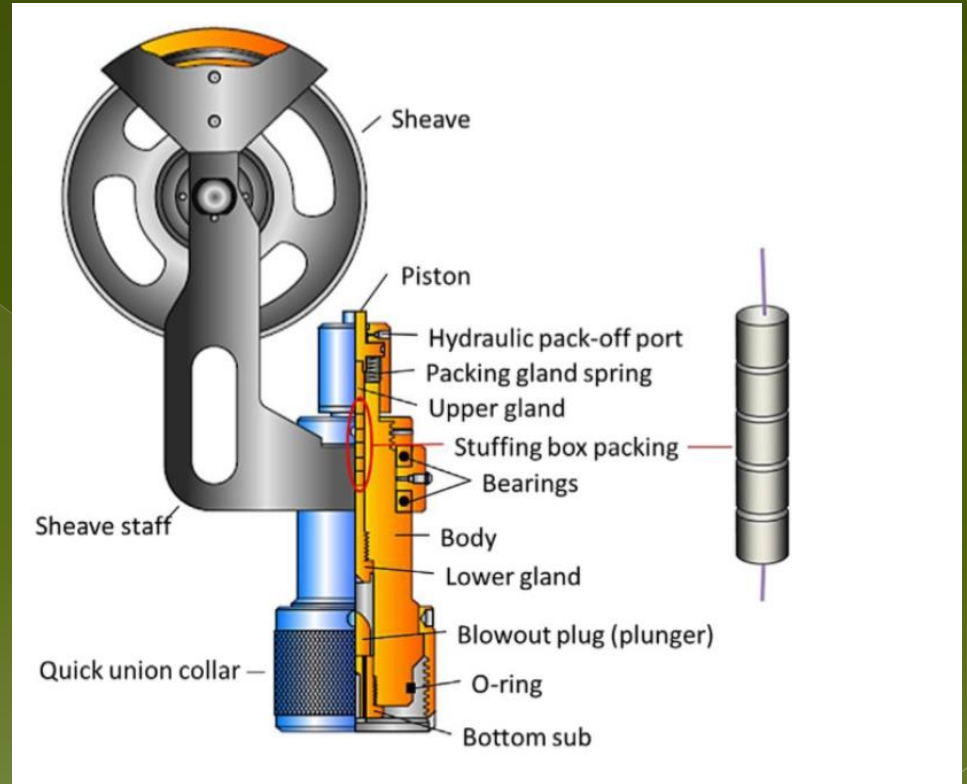

LUBRICATOR

- To provide space for the tool to be contained in under pressure when opening and closing the wellhead
- Have non ported and ported
- Available in 2ft , 4ft , 8ft
- The length of lubricator depends on the tool string length
- The longer the downhole tools the more lubricator needed

Working Pressure (WP) psi *	Test Pressure (TP) psi
3,000	4,500
5,000	7,500
10,000	15,000
15,000	22,500

QUICK TEST SUB

- Inserted above BOP at the position of the joint normally opened to insert and retrieve tools from the well
- Achieved by connecting hydraulic hand pump to the QTS port and testing the joint O-ring seal from the outside
- Can perform first pressure test to check integrity of the whole string and subsequent pressure test to verify integrity of joint disconnected rather than having to test the whole assembly again.



BLOWOUT PREVENTER

- A BOP also known as a wireline valve is installed between the tree connection and lower lubricator section
- Mechanical or hydraulic force is applied to close rams which seal against the wire
- As secondary pressure barrier
- BOP will only hold pressure from one direction (below)
- The sizes available and commonly used are 3", 4" and 7"



BLOWOUT PREVENTER

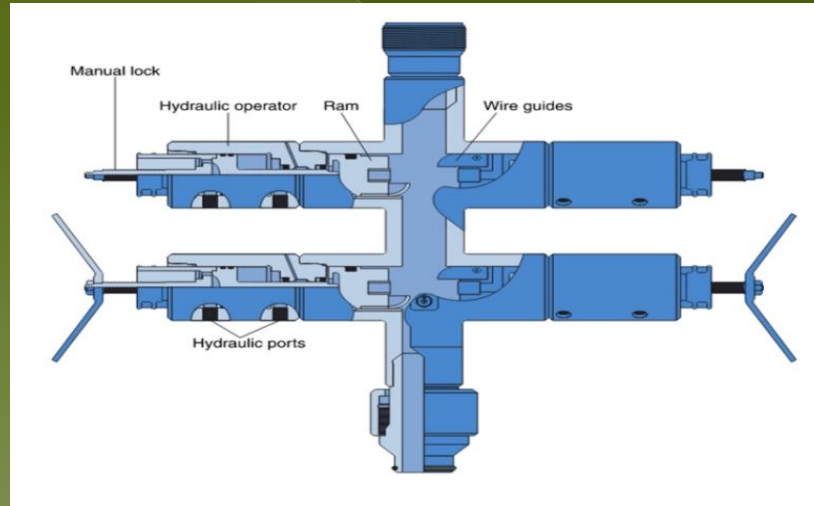
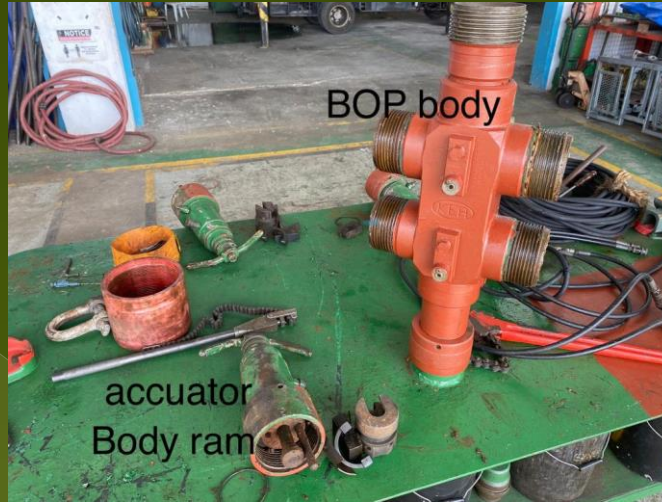
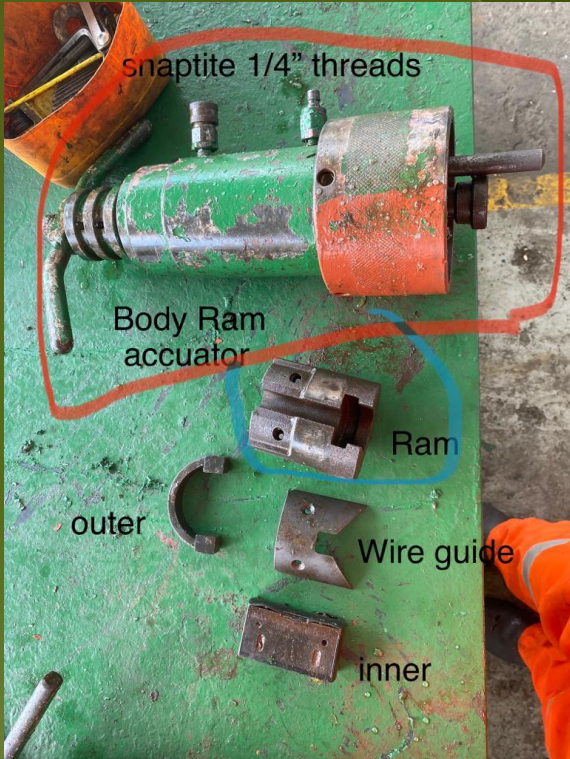

BALL VALVE

- Designed to hold well pressure below and above, testing PCE prior to running tools into the well and have ability to cut wire.
- Fully opening hydraulic controlled valve. Manually operate by use or torque handle.
- Hold pressure from both above and below.
- Placed below the BOP and above wellhead, as a additional wellhead valve.



PUMP IN TEE

- Normally positioned below BOP and above wellhead
- Specially design pumping tee, with different top and bottom unions are used as wellhead adapter crossover
- To allow well control by pumping the fluid below closed BOP
- As wellhead adapter X-overs, with different top and bottom unions
- To provide a large bleed off path for the string, particularly useful for gas wells.

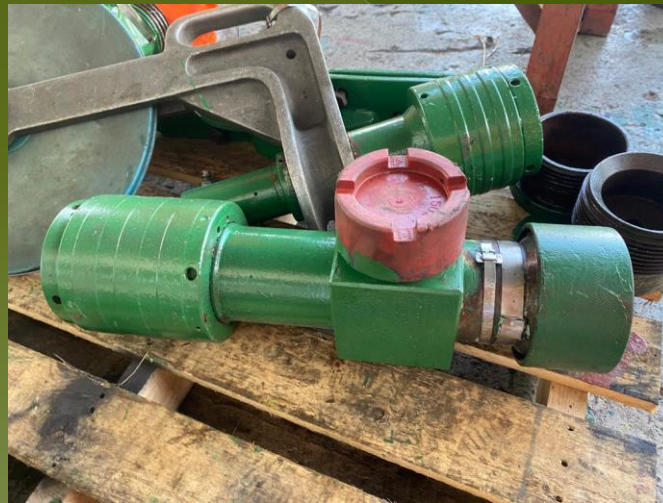

LOW TORQUE VALVE

- Is a lubricated, straight pocket, quarter-run plug valve for rapid full open or closed operation
- Protruding lugs are hit with a sledgehammer to tighten the connection and energize the seals
- Operation of the valve requires a quarter turn (90degree) of the plug using a bar
- These type of valve have one or more horizontal passageways to allow flow through the valve when open



Plug

**Protruding
lugs**

CROSSOVER

- To provide transition between different size threads size and otherwise incompatible unions made by same or different manufactures.
- Designed with union box up, union pin and collar down.



CONTROL PANEL

- **CONTROL PANEL(CP)** – to operate BOP ram
- **SINGLE WELL CONTROL PANEL(SWCP)**- to operate MV and SCSSV
- **WELL CONTROL PANEL(WCP)**- an integrated CP can operate BOP, Stuffing box, MV and SCSSV
- Provide a high pressure oil output from a low pressure air or gas input
- Air input usually supplied by air compressor or rig supply



CP ,SWCP & WCP



Control panel



Well Control Panel



Single Well Control Panel

PRESSURE TEST UNIT (PTU)

- To pump fluid or pressure test the PCE component or similar equipment
- Feature a high volume pump for fast filling and high pressure pump for testing up to a maximum 15,000 psi
- Is suitable for use with water
- The test result is recorded on chart recorder



ACCESSORIES

Lifting test cap



Stand



Dolley



Lifting clamp



PCE CONFIGURATION

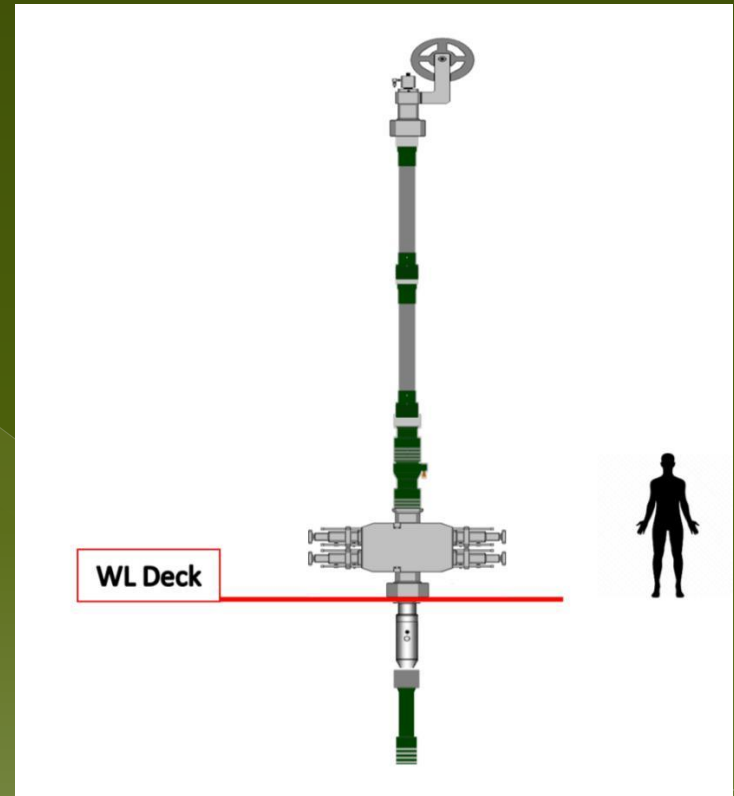
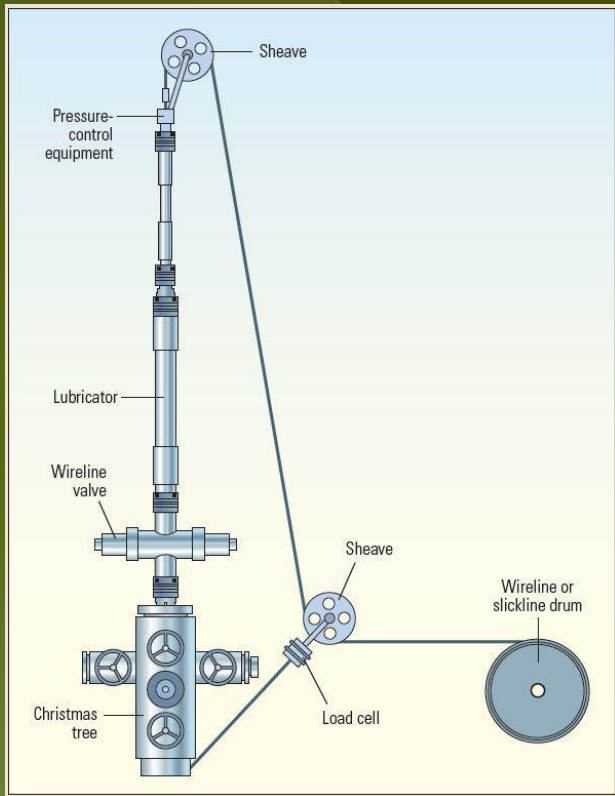

DOWNHOLE TOOLS

ROPE SOCKET

DOWNHOLE TOOLS CONNECTION

SWIVEL JOINT

STEM/WEIGHT BAR

LINK JAR

KNUCKLE JOINT

GS(PULLING TOOL)

X-LINE(RUNNING TOOL)

ROPE SOCKET

- Used as a method of connection the slickline wire to the tool string ,from wire sizes from 0.108", 0.125" and 0.140"
- 3 type of rope socket (PEAR DROP TYPE, SPRING , DISC TYPE and BRAIDED CLAMP TYPE)
- For tubing 3-1/2 RS size 1-7/8 , tubing 2-7/8 RS size 1-1/2 , tubing 2-3/8 RS size 1-1/4

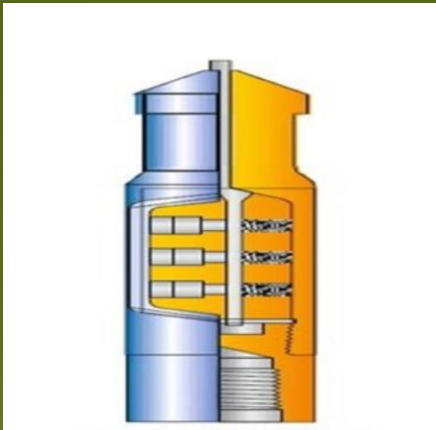

Disc type



Clamp type



Pear drop type

DOWNHOLE TOOL CONNECTION

- Sucker rod
- Quick lock system (QLS)
- Quick release joint (QRJ)
- Trinity



Sucker rod



QLS



Trinity

QRJ

QRS

DOWNHOLE TOOLS CONNECTION

CONNECTION SIZE

Sucker rod thread(TPI)

- 15/16-10
- 1 1/16
- 1 9/16

Quick lock system

- 1 1/2
- 1 7/8
- 2 1/2

Shear pin size

- 1/8
- 3/16
- 1/4
- 5/16
- 3/8



SWIVEL JOINT

- Swivel joint is a wireline accessory used to minimise the effect of the wire twist caused by subsurface devices being run
- The swivel joint has a double fish neck
- Sideways movement of swivel varies from 1.5 to 5 degree
- Different between swivel joint and knuckle joint is the sideways angle & swivels have bearing for rotation



LINK JAR

- It is also known as Spang jar / mechanical jar
- Design to act like a sliding hammer by utilising the weight of the stem bars to convey a powerful jarring action
- Available with 20 inches known as 20" stroke and 30 inches known as 30" stroke
- Other type of jar are hydraulic jar , tubular jar , spring jar , and upstroke jar



STEM

- It is known as weight bar/sinker bar
 - To provide the weight of the tool string
 - Also giving a weight impact while jarring operation
 - Available in 2ft , 3ft , 5ft
 - Other type of stem:
 1. Roller stem
 2. Lead filled stem(keys)
 3. Tungsten stem(line in middle)
- *The heaviest is tungsten stem*



STEM



**ROLLER
STEM**

KNUCKLE JOINT

- Knuckle joint are used to add flexibility within the tool string and are particularly effective within deviated well bores
- 15 degree angle movement and should be used only when necessary
- It is usually positioned immediately below the mechanical jars



GS PULLING TOOL

- The GS pulling tool is one of the types of pulling tool whose function is to pull out any subsurface flow control devices which have internal fishing neck. It gets deployed with the internal fishing neck and thus retrieves them
- Type GS series are design to latch internal fishing neck and to shear and release by downward jar action
- Before operation, the spring loaded dog set must be function tested, enabling them to move into retract position
- Type GS Otis also can be used as running tool.



X LINE RUNNING TOOL

- Also known as 'X' line or 'XO' running tool. Is constructed to deploy the flow of subsurface control devices and set type X and XN lock mandrel in their corresponding downhole nipple.
- Allow lock mandrel to be run in 2 positions:-
 - A) selective position : Used when setting in any profile except a top one or no-go (XN) profile. To run 'X' lock with its locking keys retracted
 - B) Non-selective position : Used when setting the lock in a top profile or no-go(XN) profile
- Jar down to shear top pin and jar up to shear bottom pin

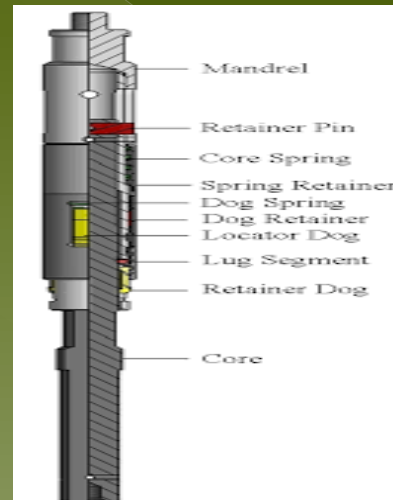



THANK YOU