



UMT003

Document: MN-UMT003-D

**Ultrawire™ Memory Tool**

# ULTRAWIRE™ MEMORY TOOL

## Operational & Maintenance Manual

**Date:** 3rd August 2006  
**Author:** Ferry van der Vorst  
**Revised:** October 2008  
**Approved:** Robert Holding

Tel: +44(0)1252 862 200 <http://www.sondex.com>  
Fax: +44(0)1252 862 349 email: [support@sondex.com](mailto:support@sondex.com)

This document contains proprietary information. Copyright © 2006-2008 Sondex. All rights reserved.  
Created: October 21, 2008

---

**Contents**

<b>0</b>	About This Manual. . . . .	<b>0-1</b>
	0.1 Manual History	0-1
	0.2 Updates To Be Used With This Manual	0-1
	0.3 Technical Help	0-1
	0.4 Feedback	0-1
<b>1</b>	Description. . . . .	<b>1-1</b>
	1.1 Operating Principle	1-1
	1.2 Applications	1-1
	1.3 Specification	1-2
<b>2</b>	Safety . . . . .	<b>2-1</b>
<b>3</b>	Theory of Operation. . . . .	<b>3-1</b>
	3.1 UMT Operation Overview	3-1
	3.2 Description	3-1
	3.2.1 Microcontroller	3-1
	3.2.2 Clocks & Watchdogs	3-2
	3.2.3 Power Supply	3-2
	3.2.4 SLang Interpreter	3-2
	3.2.5 Ultrawire™ Interface	3-2
	3.2.6 ABC Bus Flash Logging Memory	3-3
	3.2.7 MCU ABC Bus Interface	3-3
	3.2.8 Sounder	3-3
	3.2.9 Debug & Programming Interface	3-3
<b>4</b>	Operating Procedure . . . . .	<b>4-1</b>
	4.1 Pre-Logging Checks	4-1
	4.1.1 Mechanical	4-1
	4.1.2 Electrical	4-1
	4.1.3 Programming	4-1
	4.2 Connecting to Toolstring	4-2
	4.3 Logging	4-2
	4.4 Post Logging Disassembly	4-3
	4.4.1 Toolstring	4-3
	4.4.2 Programming	4-3
	4.5 Transport, Handling & Storage	4-3

---

<b>5</b>	<b>Mechanical Description . . . . .</b>	<b>5-1</b>
5.1	Description	5-1
5.2	Disassembly	5-1
5.2.1	Pressure Housing	5-1
5.2.2	Lower Connector	5-1
5.2.3	Lower Sub	5-2
5.2.4	Electronics	5-2
5.3	Reassembly	5-2
5.3.1	Electronics	5-2
5.3.2	Lower Sub	5-2
5.3.3	Lower Connector	5-3
5.3.4	Pressure Housing	5-3
<b>6</b>	<b>Electrical Description . . . . .</b>	<b>6-1</b>
6.1	Processor, PSU & Interface	6-1
6.2	64MB Flash Memory	6-3
<b>7</b>	<b>Extended Checks . . . . .</b>	<b>7-1</b>
7.1	Preventative Maintenance	7-1
7.1.1	Grease & Lubricants	7-1
7.1.2	Mechanical	7-1
7.1.3	Electrical	7-2
7.1.4	Ageing of Electronics	7-2
7.1.5	Heat Testing Above 150°C	7-2
7.2	Extraordinary Maintenance	7-2
7.3	Troubleshooting	7-3
	<b>Appendix A Equipment &amp; Recommended Spares . . . . .</b>	<b>A-1</b>
A.1	Ancillary Equipment	A-1
A.2	Maintenance Equipment	A-1
A.3	Recommended Spares	A-1
	<b>Appendix B Drawings &amp; Parts Lists . . . . .</b>	<b>B-1</b>
B.1	Mechanical Drawings	B-1
B.2	Electrical Diagrams	B-1
	<b>Appendix C UMT Sound Library . . . . .</b>	<b>C-1</b>

## 0 ABOUT THIS MANUAL

### 0.1 MANUAL HISTORY

Date	Issue	Description	Auth	Chk	App
03/08/06	A	First Issue. MN-UMT001 replaced/split up in UMT003 & UMT004. UMT001 & UMT002 Obsolete. Updates also include ECR: 2835, 3384, 2027, 3873, 3959 & 2369. Sound Library added.	FV	KW	KW
05/03/07	B	Drawing updates: ECR4156.	FV	FV	RLH
05/06/08	C	Drawing update: ECR 4631 (CD-85062)	RS	RH	RH
21/10/08	D	Drawing update: ECR 3233, 3697, 3721, 3789, 4198, 4516, 4556, 5154 & 5427	RS		

### 0.2 UPDATES TO BE USED WITH THIS MANUAL

Consult the CD Directory for the appropriate Manual Updates to be used with this Manual.

### 0.3 TECHNICAL HELP

For further technical help, contact Sondex as follows:

Address: Unit 1, Saxony Way  
Blackbushe Business Park  
Yateley, Hampshire  
GU46 6AB  
United Kingdom  
Tel: +44(0)1252 862 200  
Fax: +44(0)1252 862 349  
Web: [www.ge-energy.com/oilfield](http://www.ge-energy.com/oilfield)

### 0.4 FEEDBACK

Please help us improve future issues of this manual by adding your comments or corrections to [www.ge-energy.com/oilfield](http://www.ge-energy.com/oilfield), referencing the document number.

Thank You

**Photographs and sketches are for illustration purposes only. Depending on the tool model that you have, certain features or dimensions may differ from those shown.**

**Documents from external sources (i.e. MSDS), supplied with/referenced in this manual, are considered the latest version at time of manual issue. However, the document can be altered by the external source without prior notice to Sondex.**

## **1 DESCRIPTION**

Ultrawire™ Logging Tools can be run on slickline or coiled tubing to acquire and store data from Ultrawire™ PL and Inspection tools.

A Memory section is programmed and downloaded using an IBM® compatible PC, running MEMLOG software, via an interface. Once powered by a high capacity Lithium battery within a separate battery holder (MBH), data is acquired and stored in accordance with a user defined 'profile'. This controls the sensors logged, the sampling rates and the profile scheduling.

Sondex MEMLOG software is supplied with all memory tools, providing a graphical interface for programming and downloading the tool, together with capabilities for merging memory tool data with depth-time files from the Sondex Depth Time Recorder (DTR).

### **1.1 OPERATING PRINCIPLE**

Data from the logging sensors is transmitted via the Toolbus to the memory tool at the top of the string. Data is stored in nonvolatile flash memory chips under the control of a downhole processor. The tool can support all the standard Sondex Ultrawire™ tools and record readings from every sensor at up to 50 sets per second.

### **1.2 APPLICATIONS**

- Slickline & Coiled Tubing Production Logging.
- Production/Injection Well Profiling.
- Multifinger Imaging Tool Surveys.



**Figure 1.1 UMT**

### 1.3 SPECIFICATION

Parameter	Specification	Remarks
Diameters Available	1 <sup>11</sup> / <sub>16</sub> " (43mm)	
Maximum Temperature	350°F (177°C)	
Maximum Pressure	15,000psi (103MPa)	
Tool Shipping Length	29.46" (748mm)	
Tool Make-up Length	25.66" (652mm)	
Weight	10.6lb (4.8kg)	
Supply Voltage	+13.5 - 20VDC	
Standby Current	2mA	
Writing Current	15 - 25mA	
Tool Programming	via MIP interface box	
Tool Downloading	via MIP up to 4MB/min (computer dependent)	
Sample Rates	Programmable from 20ms to days in 20ms increments, independent for each tool and each profile.	
Number of channels	Up to 62 tools (Ultralink™)	
Capacity	Dependent on tool type and sampling rate	64MB will record up to 6 PL tool outputs plus pressure data @ 1 sec intervals for 100 hours.
Memory	128MB Flash Logging Memory.	
Maximum Toolbus Rate	500kbps	
Materials	Corrosion Resistant Throughout	
End Connectors		
Top	9 pin Fischer connector (female socket)	For connection to MBH or MCU (via lead)
Bottom	4mm single conductor (female socket)	For connection to Sondex Ultrawire™ Tools
Tools Supported	Sondex Ultrawire™ Tools.	

## 2 SAFETY

Do not apply mains power to the tool. This will seriously damage the tool, and put personnel at risk of electric shock if the tool is open.



### Warning!

**HOT WORK!** Sondex equipment may, under certain circumstances or failure modes, become a potential source of ignition. Using it must therefore be considered "**HOT WORK**" and appropriate precautionary procedures should be followed when testing at surface in areas where there is a risk of gas leaks or other potentially explosive atmospheres.



### Liquid O-ring

LOR101 is used for lubricating the tool during maintenance. Contact with skin or eyes can be harmful. For more details, refer to the Material Safety Data Sheet for Liquid O-ring.



### Caution!

#### Electro Static Discharge (ESD)

All tools with electronic boards that contain solid state circuits (transistors, diodes, semiconductors) may become damaged when contacted with an electrostatic charge.

When handling tools, which contain electronic parts that are ESD sensitive, the following guidelines should be followed to reduce any possible electrostatic charge build-up on the user's body and the electronic parts:

- Always ensure proper ESD precautions are taken when handling electronic parts that are ESD sensitive during maintenance.
- Avoid touching the tool electronics, unless stated otherwise in this manual.

Note that ESD is less likely to affect tools when the housing is fitted.

### 3 THEORY OF OPERATION

#### 3.1 UMT OPERATION OVERVIEW

The UMT sends scheduled Ultrawire™ commands to tools and logs their response in Flash memory.

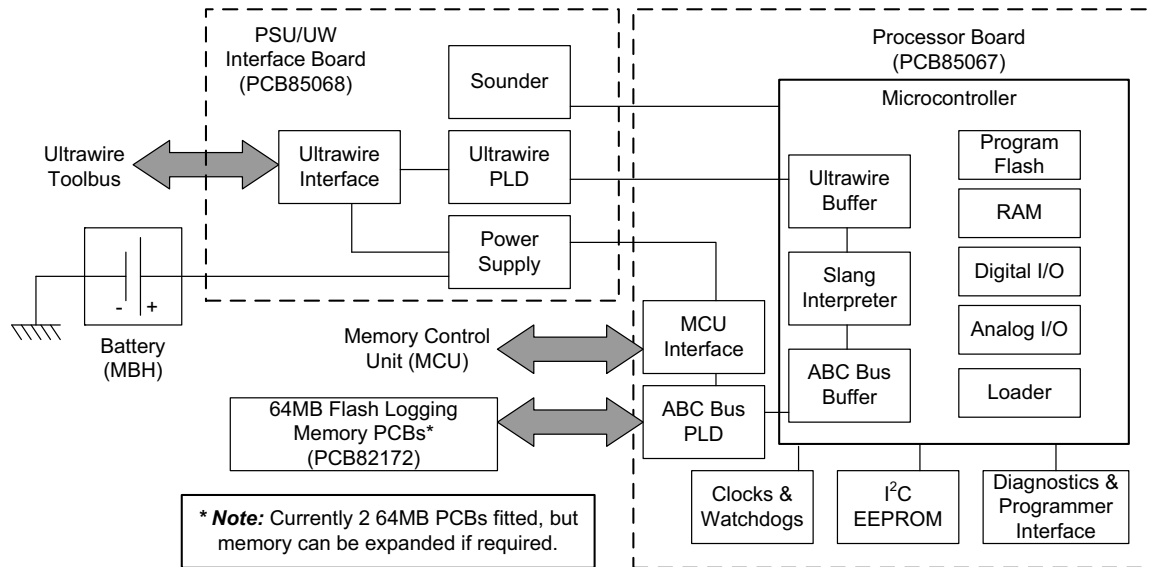

Figure 3.1 UMT Block Diagram

UMT comprises nine main functional blocks, which combine microcontroller firmware with electronic hardware:

- Microcontroller.
- Clocks & Watchdogs.
- Power Supply.
- SLang Interpreter.
- Ultrawire™ Interface
- ABC Bus Flash Logging Memory.
- MCU ABC Bus Interface.
- Sounder.
- Debug & Programming Interface.

#### 3.2 DESCRIPTION

##### 3.2.1 MICROCONTROLLER

The microcontroller is a Renesas 16bit M16C series part and includes 128kB of Flash program memory and 10kB RAM. In addition, the device has a host of on-chip peripherals including digital and analog I/O, serial ports and timers.

The UMT firmware is embedded in the microcontroller Flash program memory at manufacture, and may be subsequently reloaded or upgraded using PC software and a Sondex MCU.

### **3.2.2 CLOCKS & WATCHDOGS**

The main system clock runs at 8MHz and is operational during data logging. In order to save power, the microcontroller can switch to a 32kHz clock and turn off the 8MHz clock before sleeping. The 32kHz clock is always running and is generated by a PIC microcontroller, which also provides a temperature-compensated 1 second pulse for sleep timing. The PIC firmware reads the UMT temperature from a combined LT1019 voltage reference/temperature sensor, using an ADC channel, and indexes a table of pre-calculated compensation values, which are used to adjust a 1 second timer.

A watchdog monostable resets the system should the 1 second timer fail. A second watchdog system counts 1 second ticks and resets the system after 255 seconds if not triggered. These watchdogs will automatically be deactivated if necessary, to allow operation without sleep should the 1 second timer fail.

### **3.2.3 POWER SUPPLY**

The main power supply, used during logging, is a switch mode type providing regulated 5V and 3V3 rails from a nominal 18V supply. During low power sleep periods, this is disabled by the microcontroller and the 32kHz oscillator, and watchdogs are run from a series regulator. The microcontroller RAM and register contents are also maintained by this regulator. Note that the 32kHz oscillator PIC runs from a slightly higher voltage to aid restart at high temperatures.

The Toolbus supply includes a programmable and resettable current limit, as well as tool and toolstring current monitors and a battery voltage monitor.

### **3.2.4 SLANG INTERPRETER**

SLang (Sondex Logging Language) comprises a list of commands - a logging schedule - which is interpreted by the UMT. Most of these commands generate Ultrawire™ words to operate and log tools over the Toolbus, some of them are concerned with internal UMT operations and some with flow control of the logging schedule itself. SLang code is generated from its high-level representation (Graffiti) by PC software and is downloaded to UMT before use.

The SLang interpreter operates from a 20ms timer interrupt and is responsible for the correct sequencing and timing of all UMT operations while logging. Ultrawire™ words are assembled and sent to the Ultrawire™ buffer, and block header information is sent to the ABC Flash buffer. Returned Ultrawire™ words are routed to the ABC Flash buffer.

### **3.2.5 ULTRAWIRE™ INTERFACE**

The Ultrawire™ electrical interface comprises a Sondex capacitor-coupled, choke-isolated AMI interface, which uses a single conductor (the Toolbus) for both power and half duplex data. The serialization and coding is split between a 32 macrocell Coolrunner Programmable Logic Device (PLD), two microcontroller synchronous serial ports and several microcontroller digital I/O pins.

Ultrawire™ commands are queued if necessary and transmitted at high speed. Received data is checked and queued for Flash writing. Data transmission and reception is controlled by an intelligent buffering algorithm, which takes account of timeouts and errors.

### **3.2.6 ABC BUS FLASH LOGGING MEMORY**

Sondex ABC bus Flash logging memory is supplied as 64MB modules. UMT can support 2GB of logging memory: the available module addressing scheme allows up to 512MB at present.

Received Ultrawire™ data is queued, if necessary, and written to logging Flash memory over the ABC bus along with queued header data. Firmware automatically checks the integrity of individual Flash chips while logging to ensure a high degree of fault-tolerance.

The interface between the microcontroller and Flash logging memory is implemented in a 32 macrocell Coolrunner PLD, which is accessed by using microcontroller digital I/O lines.

### **3.2.7 MCU ABC BUS INTERFACE**

A Sondex MCU may be connected to the UMT ABC bus, using a bi-directional buffered interface. This allows the MCU to monitor logging operations and to directly access the logging memory.

File transfer routines allow uploading and downloading of UMT firmware, SLang logging control files and Chip Allocation Tables to and from the UMT. These routines are separate from the main firmware and are initiated by a MCU master line control sequence at boot-up.

### **3.2.8 SOUNDER**

A piezoelectric sounder is used to signal various conditions using short pips or tunes. SLang, generated from high-level Graffiti, automatically inserts a binary sequence of four pips into each scan loop to indicate the loop number starting from 1. For example, Bop-Bop-Bip-Bop indicates 0010 binary or loop number 2.

### **3.2.9 DEBUG & PROGRAMMING INTERFACE**

The M16C microcontroller contains a factory programmed bootloader, which uses one of the serial ports, and is activated by holding the program line Hi while resetting. An external level shifter and inverter allows connection to a PC serial port. Normally, this would only be used for initial programming, service and development as the MCU ABC bus interface is more readily available for program updates.

This same connection can also be used to run an ANSI terminal (in practice, a terminal emulator program running on a PC) at 38,400 baud, which allows the Test Engineer to monitor and control most of the UMT functionality with single keystrokes.

## 4 OPERATING PROCEDURE

### 4.1 PRE-LOGGING CHECKS

#### 4.1.1 MECHANICAL

- 1 Clean and grease upper and lower O-ring seals. Replace O-rings if damaged.
- 2 Ensure upper and lower electrical connectors are clean, dry and undamaged.

#### 4.1.2 ELECTRICAL

- 1 Using a multimeter, measure the pin to housing resistance:

##### Upper Connector:

- Pin 1: >400kΩ
- Pin 2: <0.5Ω
- Pin 3: >1MΩ
- Pin 4: >1MΩ
- Pin 5: >1MΩ
- Pin 6: approx. 10kΩ
- Pin 7: >400kΩ
- Pin 8: approx. 10kΩ
- Pin 9: >1MΩ

##### Lower Connector:

- Ultrawire™ Line: 3-4MΩ

#### 4.1.3 PROGRAMMING

- 1 Before the UMT can be used for logging, it must be programmed with a job profile. MEMLOG software can be used to create the job profile and does not require the UMT to be connected during this process, see [MN-MEMLOG](#).
- 2 When the job profile has been created, remove upper thread protector and connect the UMT as shown in [Figure 4.1](#). Refer to [Appendix A Equipment & Recommended Spares](#) for equipment details.

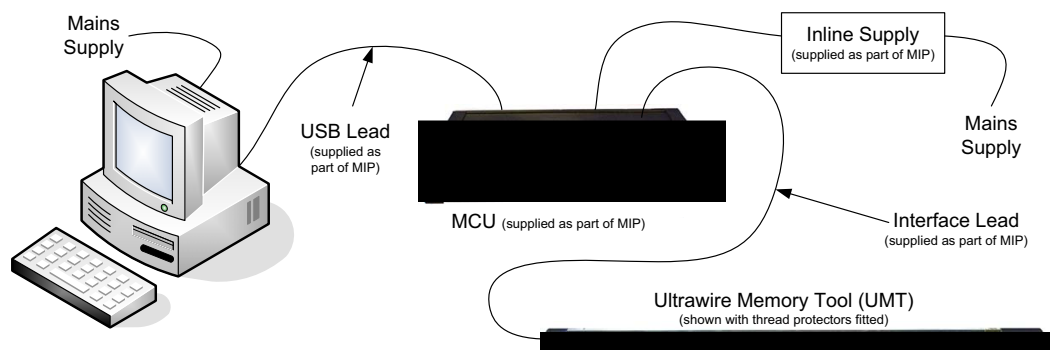

Figure 4.1 Programming Connection Diagram

- 3 Program the UMT as detailed in the MEMLOG manual *MN-MEMLOG*.
- 4 Remove power and disconnect. To protect the electrical connectors, ensure both thread protectors are fitted until the toolstring is ready for logging.

## 4.2 CONNECTING TO TOOLSTRING

Upper and lower tool joint O-rings and seal surfaces should be clean, undamaged and lightly greased.

The UMT should be located below the MBH at the top of the toolstring and above the Ultrawire™ tools.

The UMT includes a sounder, which indicates the operating mode. The various sounds emitted, and their timing, depend on the stored logging profile, see Memlog Manual *MN-MEMLOG* for further details.

## 4.3 LOGGING

The following are guidelines only and must be used in conjunction with local policy and specific well site conditions both downhole and at surface. The table below is appropriate for near vertical wells and must be adjusted accordingly when in deviated wells. Use of a Head Tension Unit is highly recommended.

**Note:** Do not exceed the calculated safe working load of your selected weakpoint. If in doubt, use a head tension unit, especially in deviated wells where calculation from surface tension is less accurate.

Depth (ft)	Speed Pulling Out of Hole	Speed Running in Hole
In/out of catcher (pressure rig up only)	Dead slow or manual.	
30 to 150	30ft/min	
150 to 400	60ft/min	
>400 clear cased hole	Surface tension not to exceed 120% of tension when tool stationary. Speed not to exceed 150ft/min.	Surface tension should not be less than 80% of tension when tool stationary. Speed not to exceed 150ft/min.
>400 clear open hole	Surface tension not to exceed 130% of tension when tool stationary. Speed not to exceed 150ft/min.	Surface tension should not be less than 70% of tension when tool stationary. Speed not to exceed 150ft/min.
Approaching potential obstacles <sup>a</sup>	30ft/min	
Logging Data	Do not exceed the above speeds.  Recommended speed is <30ft/min.	

a. For example: Reduced diameters, gas lift mandrels, fluid levels, valves, tubing shoes, packers, cross overs and other downhole equipment.

## **4.4 POST LOGGING DISASSEMBLY**

### **4.4.1 TOOLSTRING**

Clean the tool before the toolstring is disassembled.

Ensure that well fluid does not reach the electrical connectors.

Refit thread protectors.

### **4.4.2 PROGRAMMING**

Remove the upper thread protector and connect the UMT as per [Figure 4.1](#). All operations are performed within the MEMLOG software. Refer to [MN-MEMLOG](#) for procedure.

## **4.5 TRANSPORT, HANDLING & STORAGE**

Store with end threads lightly greased and with water tight thread protectors fitted.

## 5 MECHANICAL DESCRIPTION

### 5.1 DESCRIPTION

The Ultrawire™ Memory Tool (UMT) comprises a number of circuit boards contained in a pressure housing.

The top tool joint is designed to connect to a logging battery pack (MBH) or a Sondex MIP lead.

The lower tool joint is a standard Sondex monoconductor.

The principal elements are as follows:

- Pressure Housing.
- Processor Circuit Board.
- PSU/UW Interface Circuit Board.
- 64MB Memory Circuit Boards.
- Upper End fitted with Fischer connector.
- Lower End fitted with monoconductor socket.

### 5.2 DISASSEMBLY

**Note:** Item numbers refer to the general assembly, unless stated otherwise.

#### 5.2.1 PRESSURE HOUSING

Ref.: General Assembly 09679

Unscrew pressure housing (item 2) from lower sub (item 1).

**Note:** The electronics section internal chassis is hard wired to the lower sub and remains fixed by grub screws (3x item 10).

#### 5.2.2 LOWER CONNECTOR

Ref.: General Assembly 09679  
Lower Connector Assembly 10057

- 1 Remove circlip (item 7).
- 2 Carefully unscrew nut with wire attached (item 3, 10057) from connector and remove the connector assembly from the lower sub (item 1). It is not necessary to remove the anti-rotation pin (item 14).

### 5.2.3 LOWER SUB

Ref.: General Assembly 09679

**Note:** It is generally not necessary to separate the lower sub from the chassis.

- 1 Carry out [Section 5.2.1](#) and [Section 5.2.2](#) before continuing.
- 2 Screw grub screws (3x item 10) **inwards (clockwise)**. This will release the lower sub (item 1) from the electronic chassis (item 3).
- 3 Remove wavy washer (item 12).

### 5.2.4 ELECTRONICS

Carry out [Section 5.2.1](#) before continuing.

Ref.: Mechanical Chassis 20411

Remove screws (8x item 5, 20411) and remove top halfshell (item 4, 20411).

**Note:** The lower halfshell forms an integral part of the chassis and should not be removed.

## 5.3 REASSEMBLY

**Note:** Item numbers refer to the general assembly, unless stated otherwise.

### 5.3.1 ELECTRONICS

Ref.: Mechanical Chassis 20411

Check for damaged or crushed wires, replace where necessary. Ensure the chassis is free from debris.

Replace top halfshell (item 4, 20411) and secure with screws (8x item 5, 20411).

### 5.3.2 LOWER SUB

Ref.: General Assembly 09679

- 1 Inspect the line wire for damage, replace if necessary. Ensure all inner spaces are free from debris.
- 2 Fit wavy washer (item 12) into lower sub (item 1).
- 3 Align lower sub (item 1) and hold in place by screwing the grub screws (3x item 10) evenly **outwards (anti-clockwise)** until tight.

**5.3.3 LOWER CONNECTOR**

Ref.: General Assembly  
Lower Connector Assembly

09679  
10057

- 1 Replace and grease O-ring (item 6) in lower sub (item 1).
- 2 Carefully replace nut with wire attached (item 3, 10057) on to the connector.
- 3 Fit lower connector assembly (item 5) into lower sub (item 1), ensuring that lower connector assembly seats correctly against anti-rotation pin (item 14) and the wire is not crushed.
- 4 Replace circlip (item 7).

**5.3.4 PRESSURE HOUSING**

Ref.: General Assembly  
Electronics Assembly

09679  
85069

- 1 Check upper connector (item 8, 85069) for damaged contacts.
- 2 Clean and grease O-ring seals. Replace the following O-rings if damaged:
  - 1x item 4.
  - 2x item 11.
  - 2x item 8.
- 3 Clean pressure seal surfaces at both ends of the pressure housing (item 2). Ensure that the housing is free from debris.
- 4 Screw pressure housing (item 2) on to the lower sub (item 1).
- 5 Ensure thread protectors (item 13 & 9) are fitted.

## 6 ELECTRICAL DESCRIPTION

Ref.: UMT General Assembly Wiring Diagram [WD-85069](#)

### 6.1 PROCESSOR, PSU & INTERFACE

Ref.: Processor Board Circuit Diagram [CD-85062](#)  
PSU/UW Interface Board Circuit Diagram [CD-85064](#)

[**This\_style** denotes a microcontroller I/O pin or other named signal.]

#### Reset

After a reset, the microcontroller I/O pins become high impedance inputs awaiting configuration. Several of these pins are used to control peripherals and are connected to external pull-up or pull-down resistors to assert their status after a reset.

A global reset is provided by U4, which holds the **RST** signal low for 100ms after power up or after a watchdog reset.

#### Switch Mode Power Supply (SMPS)

The SMPS, based around U13, provides a single 5V supply and two 3V3 supplies. These supplies should be accurate to  $\pm 0.25V$  and are generated with reference to the 2.5V output of U14.

In addition the 5V rail is supplemented by a 4.5V linear regulator based around U1 and Q8. This acts a 'catcher' and allows this rail to supply momentary high current pulses to accommodate some types of memory chip.

#### LF Oscillator Operation

The LF oscillator is implemented, using a PIC12F675 8-pin processor, which also provides a temperature compensated 1Hz clock.

The LF Oscillator PIC is run from the battery supply with a shunt regulator, formed by R6 resistor and a forward biased diode, D1 sitting atop the 2V8 linear regulator rail. This gives a nominal 3V5 supply when in standby and about 3V9 when the system is fully powered.

#### Elapsed Time Clock

The 1Hz **Ticks** signal feeds a 32bit counter chain within the microcontroller that acts as the Elapsed Time Clock (ETC) giving a maximum of 136 years before rollover, which is considered to be sufficient for most logging jobs. This continues to count while the microcontroller is in stop mode and is used to restart the microcontroller after a programmed SLang sleep.

The PIC, which forms part of the ETC, uses the tool temperature monitor voltage, connected to an internal Analogue to Digital Converter (ADC), to provide temperature compensation for crystal frequency drift with temperature. This compensation is applied to the 1Hz output, but not to the 32kHz output.

#### Toolstring Power Supply

The power supply is capable of passing up to 2.0A and has a programmable current trip, controlled by a microcontroller Digital to Analogue Converter (DAC). In normal use, the 0-2.5V DAC output is connected to **TBctrl** and the trip status monitor input is **TBtrip**. These may also be configured as microcontroller digital outputs to reset and trip the toolstring supply.

Toolstring current is monitored by U17, a MAX4080 hi-side current monitor IC, configured to give 200 ADC counts for 2A, which is 1.96V with a 2.5V ADC reference.

Thus:

$$I_{string} \text{ (Amps)} = \frac{N_{adc}}{100} \quad \text{Equation 6.1}$$

The current trip level DAC on **TBctr1** is set using the same scaling.

Should the monitored current exceed the set point, the op-amp output will switch to the positive rail and switch off the power control MOSFET. Positive feedback then holds the non-inverting input at a zener-limited 2.7V, which is higher than the absolute maximum DAC output.

PSU current is routed to **IBmon**, battery voltage is routed to **VBmon** and tool temperature is routed to **TTmon**. Tool temperature and the 2.5V ADC reference **ADCref** are derived from the same chip. An additional MAX4080 current monitor measures the memory tool current as 200 ADC counts = 50mA and this is connected to **ITmon** giving:

$$I_{umt} \text{ (Milliamps)} = \frac{N_{adc}}{4} \quad \text{Equation 6.2}$$

The battery voltage monitor is scaled and buffered to give 20V = 200 ADC counts, which is a full scale of 25.5V, thus:

$$V_b \text{ (Volts)} = \frac{N_{adc}}{10} \quad \text{Equation 6.3}$$

The temperature output is specified as approximately 2.1mV/K, but in practise conforms more accurately to the LT1019 data sheet graph. Empirically, the temperature calibration accurate to about ±3C is given by:

$$T_c \text{ (Celcius)} = (N_{adc} \times 0.881) - 11.2 \quad \text{Equation 6.4}$$

$$T_f \text{ (Fahrenheit)} = (N_{adc} \times 1.585) + 11.9 \quad \text{Equation 6.5}$$

### Ultrawire™ Interface

The Ultrawire™ Memory Tools (UMT) uses a mono-conductor to interface to the Ultrawire™ toolstring. This conductor, designated 'LINE' on Sondex circuit schematics provides the following functions:

- Supplies power to the toolstring.
- Carries data and commands from the memory tool to the toolstring.
- Carries data and diagnostics from the toolstring to the memory tool.

Chokes L1 and L2 (two are used for space and power reasons) isolate the DC Power Supply from data pulses on the Line. Transients on the Line are limited to ±3V by diodes D19 and D20. Ultrawire™ data pulses are ±1V.

### ABC Bus Interface

The ABC bus provides a data path between logging memory, the UMT microcontroller and a surface PC. The bus connects to the UMT microcontroller via U7, to the logging memory boards via their on board CPLD, and to a surface PC via bidirectional buffers and a Sondex MCU. The ABC bus may be used in four ways:

- Before logging, the ABC bus is used to connect a surface PC to the UMT microcontroller to load firmware and SLang prior to running a log.
- While logging, the ABC bus connects logging memory to the UMT microcontroller to allow data storage.
- After logging, the ABC bus connects a surface PC to logging memory to allow transfers of logged data.
- During testing, the ABC bus connects logging memory to the UMT microcontroller and connects a surface PC in listen-only mode to monitor bus transactions.

### Beeper

The piezoelectric sounder is controlled by **Beep**, which is driven from a microcontroller on-chip oscillator (Timer 4) under firmware control.

### Programming Port

The programming port uses microcontroller UART1. If **CNVss** is held Hi and the microcontroller is reset, manufacturer-supplied internal embedded bootcode uses **Loader\_TX** and **Loader\_RX** to download firmware from an RS232 interface. Level shifting and inversion between RS232 levels and 3.3V logic levels (e.g. MAX3232) must be provided externally.

After initial firmware loading at assembly time, UMT may be reprogrammed via the MCU and ABC bus using firmware routines.

### Diagnostic Port

The diagnostic port also uses microcontroller UART1. An external level and polarity converter is used to provide an RS232 interface running at 38462 baud (at 25°C). This port can connect to a terminal (or more usually a terminal emulator running on a PC), which is configured to be ANSI escape sequence compatible and having a display area of 24 rows by 64 columns.

## 6.2 64MB FLASH MEMORY

Ref.: 64MB Memory Board Circuit Diagram [CD-80693](#)

The ABC bus is monitored by programmed devices (U1 & U2) looking for its uniquely addressed wake up command, set by links LK1. On receiving its wake up command, it either stores or retrieves Log Data in the Log Data Memory (U3 & U4) as required by ABC bus commands. When all data transactions are complete, a sleep command on the ABC bus then places the Log Data Memory into its power saving sleep mode.

Further Memory boards can be added to increase the memory beyond its initial 64MB, each board adding another 64MB of Log Data Memory. Sondex does not currently offer tools with more than 128MB of Log Data Memory.

## 7 EXTENDED CHECKS

### 7.1 PREVENTATIVE MAINTENANCE

#### 7.1.1 GREASE & LUBRICANTS

Sondex recommends the use of "Liquid O-ring type 101" (p/n LOR101) on threads and O-rings.

All O-rings and housing threads are assumed to be and must be lightly greased, unless specifically indicated otherwise.

Correct use of grease and lubricants is essential to the maintenance of all Sondex downhole equipment.

Note that some threads are internal, which can cause grease to get inside the tool. Do not use excessive quantities.

Sondex does not recommend Copper loaded greases since some types can cause electrical leaks. Some types for grease are not suitable for use on O-rings. Silicone grease may be used on O-rings, but must be kept clear of threads, especially stainless steel to stainless steel.



#### Caution!

The use of certain greases, which contain volatile content, (e.g. some types of Lubriplate) can cause electrical failure due to production of corrosive gasses inside the tool when burned off.

#### 7.1.2 MECHANICAL

Ref.: General Assembly **09679**

- 1 Remove dirt and old grease from pressure housing threads and O-rings and replace with fresh.
- 2 Inspect O-rings for damage or ageing/hardening and replace where required.
- 3 Check for:
  - Damaged wires.
  - Wires that are loose and likely to be crushed on reassembly.
  - Damaged components.
  - Loose screws/nuts/components/connectors.

**Note:** If RTV or similar compound is used to secure loose components, it must be fully cured before housing is replaced.

- Electrical components shorting to chassis.
  - Heat or chemical damage (discoloured components).
  - Incorrect thread grease or excessive quantity, see [Section 7.1.1](#).
  - Check any connectors for cleanliness and loose/bent pins before replacing.
- 4 Check all fixings for tightness.
  - 5 Check grub screws (3x item 10) are tight.

**7.1.3 ELECTRICAL**

- 1 Tool current <25mA @ 18V.
- 2 Connect to Logging System and check for correct data. Apply some gentle vibration, rotation and invert tool to expose potential failure.
- 3 With an appropriate logging profile running, check line for +1V and -1V, 2µs pulses, with an oscilloscope. Make sure to check tool pulses, not those from the controller which occur first.

Pulses should have no ringing, if ringing, also attach a Ultrawire™ terminator at the bottom of the toolstring (e.g. Ultrawire™ bullnose terminator (BUL006) or a suitable Ultrawire™ bottom end flowmeter).

**7.1.4 AGEING OF ELECTRONICS**

At 150°C, significant electronic ageing failures are expected after 4000hrs typical use, hence PCB replacement should be considered at this point. Every additional 10°C halves the time. Life of the electronics is also accelerated by vibration and corrosive gas inside the chassis. Visual inspection and logging previous history is recommended, but is unlikely to predict premature failure.

Tools that may be suspected of reliability problems due to age or unusual log response may be heated to 120°C, which would not normally age the electronics, and afterwards subjected to moderate vibration. A moderately hard blow from a wooden hammer is recommended.

**DO NOT USE METAL HAMMERS.**

**7.1.5 HEAT TESTING ABOVE 150°C**

This is not generally recommended since it shortens tool life expectancy.

Heat testing may be required for contractual reasons, tool out of use for a long period, or job with unusually high well temperature. The test should be carried out slightly above expected well temperature only and the tool should not be kept at temperature for more than 1 hour.

**7.2 EXTRAORDINARY MAINTENANCE**

Ref.: General Assembly 09679

If the tool experiences H<sub>2</sub>S, gas or temperatures above 150°C, then the following O-rings must be replaced:

- 1x item 4.
- 2x item 11.
- 2x item 8.

### 7.3 TROUBLESHOOTING

Refer to [Section 5.2 Disassembly](#) and [Appendix B Drawings & Parts Lists](#) where necessary.

An oscilloscope, multimeter and other basic test equipment will be required.

<b>Initial inspection</b>	<p>Check for:</p> <ul style="list-style-type: none"> <li>• Damaged wires.</li> <li>• Damaged components.</li> <li>• Electrical components shorting to chassis.</li> <li>• Heat or chemical damage (discoloured components).</li> <li>• Incorrect thread grease or excessive quantity, see <a href="#">Section 7.1.1</a>.</li> <li>• Check any connectors for cleanliness and loose/bent pins before replacing.</li> </ul> <p>Also check all fixings are tight.</p>
<b>Not operating</b>	<p>Check connections to the MBH.</p> <p>With the UMT disconnected from the toolstring and MBH, connect 18VDC power supply current limited to 200mA via the Fischer connector (+18V to Kemlon, 0V to chassis). The quiescent current should be between 10mA and 25mA.</p>
<b>Little or no current</b>	<p>Check the fuse, F1, on the UMT PSU board (PCB85062).</p>
<b>Power supply is current limiting</b>	<p>Check for short-circuits on the PCBs and connectors.</p>
<b>Current within range, but not operating</b>	<p>Check the supply rails at the link J31 on PCB85062. These should be 5V <math>\pm 0.25V</math> and 3.3V <math>\pm 0.25V</math>.</p> <p>Check the output of the oscillator U6 is 8MHz <math>\pm 2kHz</math>.</p> <p>Check the *RST signal at either end of R5 on PCB85062 is reading approx. 3.3V.</p> <p>Check the 1second pulses at either end of R5 on PCB85062 is producing a short pulse every second.</p> <p>If the above is OK, re-load the UMT firmware using Memlog.</p>

**APPENDIX A EQUIPMENT & RECOMMENDED SPARES**

Item	Part No.	Description	Qty	Remarks
1	UMT003	Ultrawire Memory Tool, 1 <sup>11</sup> / <sub>16</sub> " , 128MB.	1	

**A.1 ANCILLARY EQUIPMENT**

Item	Part No.	Description	Qty	Remarks
1	MIP006	Memory Control Unit (MCU) and leads.	1	Refer to <a href="#">MN-MCU003</a> .
2	-	PC or notebook running Windows® 98SE, ME, 2000 or XP with a USB connection.	1	Refer to <a href="#">MN-MEMLOG</a> for further details.

**A.2 MAINTENANCE EQUIPMENT**

Item	Part No.	Description	Qty	Remarks
1	<a href="#">91050</a>	Hand Tool Kit for 1 <sup>11</sup> / <sub>16</sub> " Tools.	1	
2	LOR101	Grease for O-rings and threads.	1	5oz pot.
3	LOR101(L)	Grease for O-rings and threads.	1	12oz pot.

**A.3 RECOMMENDED SPARES**

Item	Part No.	Description	Qty	Remarks
1	<a href="#">KITB-UMT1 11/16</a>	1 <sup>11</sup> / <sub>16</sub> " Basic Spares Kit.	1	To support 1 run in hole.
2	<a href="#">KITR-UMT1 11/16</a>	1 <sup>11</sup> / <sub>16</sub> " Recommended Spares Kit.	1	Support 25 runs in hole.

**Note:** Spares kits suitable for remote logging operation can be supplied upon request.

PARTS LISTING					
Part:	Issue:		Drawn:	Checked:	Approved:
91050	B		NGH	PD	DJF
Description:			Date:	Date:	Date:
Tool Kit for all 1 11/16 Tools SX and GO			14/01/2002	14/01/2002	14/01/2002

CHANGE HISTORY					RELATED DOCUMENTS		
Iss	Date	Remarks	Chkd	Appr	# Documents	Issue	Notes
-	14/01/2002	Initial Release	PD	DJF			
A	11/04/2006	ECR 3697 Refers - Item 018, p/n 91822 added	JC	JC			
B	25/05/2006	ECR's 3721 & 3789 refer-Item 002, qty was 1 off, item 019 added	JC	NPB			

PARTS LIST							
Item	Part No.	Issue	Description	Component Value	Qty	Units	Remarks
001	91005	-	Spanner Open Ended 42mmx38mm		2	ea	
002	91019	-	Spanner C 50mm 35mm		2	ea	
003	10038	A	Spanner Box 3/8 x 5/16 Modified		2	ea	
004	91028	-	Spanner O/E 3/8AF x 5/16AF		1	ea	
005	91027	-	Spanner Single Open End 18mm		1	ea	
006	91029	-	Key, Hex Metric (Set)		1	ea	
007	91030	-	Punch Pin Parallel set		1	ea	
008	00615	A	Assy Spanner PKJ		1	ea	
009	91293	-	Screwdriver Parallel tip (3 0 x 75)		1	ea	
010	91105	-	Toolroll With SX Badge Large Black		1	ea	
011	91104	-	Screwdriver Parallel tip (5 5 x 200)		1	ea	
012	91103	-	Pliers Circlip 812 Chrome/Van		1	ea	
013	91102	-	Pliers Mini Flat Nose 5 Inch		1	ea	
014	10037	A	Bar Tommy		2	ea	
015	10051	A	Kemlon tool Sondex - 4BA Hex Socket		1	ea	
016	91280	-	Hammer, 4oz ball pein		1	ea	
017	91130	-	Pin C Spanner 35-50mm		1	ea	
018	91822	-	Medium Flat Blade Screwdriver, 5mm		1	EACH	
019	91255	-	T15 Torx driver, Sandvik Belzer 8915		2	ea	

(AR = As Required)

PARTS LISTING						
Part:		Issue:		Drawn:	Checked:	Approved:
KITB-UMT1 11/16		A		SCA	KW	KW
				Date:	Date:	Date:
				06/06/2005	06/06/2005	06/06/2005
Description: Kit, Spares, Basic, UMT 1 11/16" Tools						

CHANGE HISTORY					RELATED DOCUMENTS		
Iss	Date	Remarks	Chkd	Appr	# Documents	Issue	Notes
A	06/06/2005	Initial release.	KW	KW			

PARTS LIST							
Item	Part No.	Issue	Description	Component Value	Qty	Units	Remarks
001	99124	-	O Ring Viton 90 Type 124		2	ea	
002	99211	-	O Ring Viton 90 Type 211		2	ea	
003	95212	-	O Ring Viton 75 Type 212		1	ea	

(AR = As Required)

PARTS LISTING						
Part:		Issue:		Drawn:	Checked:	Approved:
KITR-UMT 1 11/16		A		SCA	KW	KW
				Date:	Date:	Date:
				06/06/2005	06/06/2005	06/06/2005
Description: KIT, SPARES, RECOMMENED(25 RUN), UMT 1 11/16" Tools						

CHANGE HISTORY					RELATED DOCUMENTS		
Iss	Date	Remarks	Chkd	Appr	# Documents	Issue	Notes
A	06/06/2005	Initial release.	KW	KW			

PARTS LIST							
Item	Part No.	Issue	Description	Component Value	Qty	Units	Remarks
001	99211	-	O Ring Viton 90 Type 211		50	ea	
002	99124	-	O Ring Viton 90 Type 124		50	ea	
003	95212	-	O Ring Viton 75 Type 212		25	ea	
004	01047	-	Circlip, Internal, 5/8, St/Steel		2	ea	
005	93019	-	Pin, Spirol, 1mm x 8mm Lg, SS		2	ea	
006	95112	-	O Ring Viton 75 Type 112		2	ea	
007	93171	-	Screw Grub Skt Hd M6x05mm Lg SS - Refer 01082		3	ea	
008	01029	-	Screw, Csk Hd(Slotted), M3 x 06mm Lg, St/Steel		10	ea	

(AR = As Required)

## APPENDIX B DRAWINGS & PARTS LISTS

### B.1 MECHANICAL DRAWINGS

Description	Drawing	Parts List
General Assembly	<a href="#">09679-PT4</a>	See Drawing.
Electronics Assembly	<a href="#">85069-A</a>	See Drawing.
Mechanical Chassis Assembly	<a href="#">20411-PT2</a>	See Drawing.
Lower Connector Assembly	<a href="#">10057-D</a>	<a href="#">10057-D</a>

### B.2 ELECTRICAL DIAGRAMS

Description	Type	Drawing
UMT General Assembly	Wiring Diagram	<a href="#">WD-85069-PT3</a>
Processor Board (PCB85067) - 3 sheets	Circuit Diagram	<a href="#">CD-85062-E00</a>
PSU/UW Interface Board (PCB85068) - 3 sheets	Circuit Diagram	<a href="#">CD-85064-Ax</a>
64MB Flash memory Board (PCB82172)	Circuit Diagram	<a href="#">CD-80693-C</a>

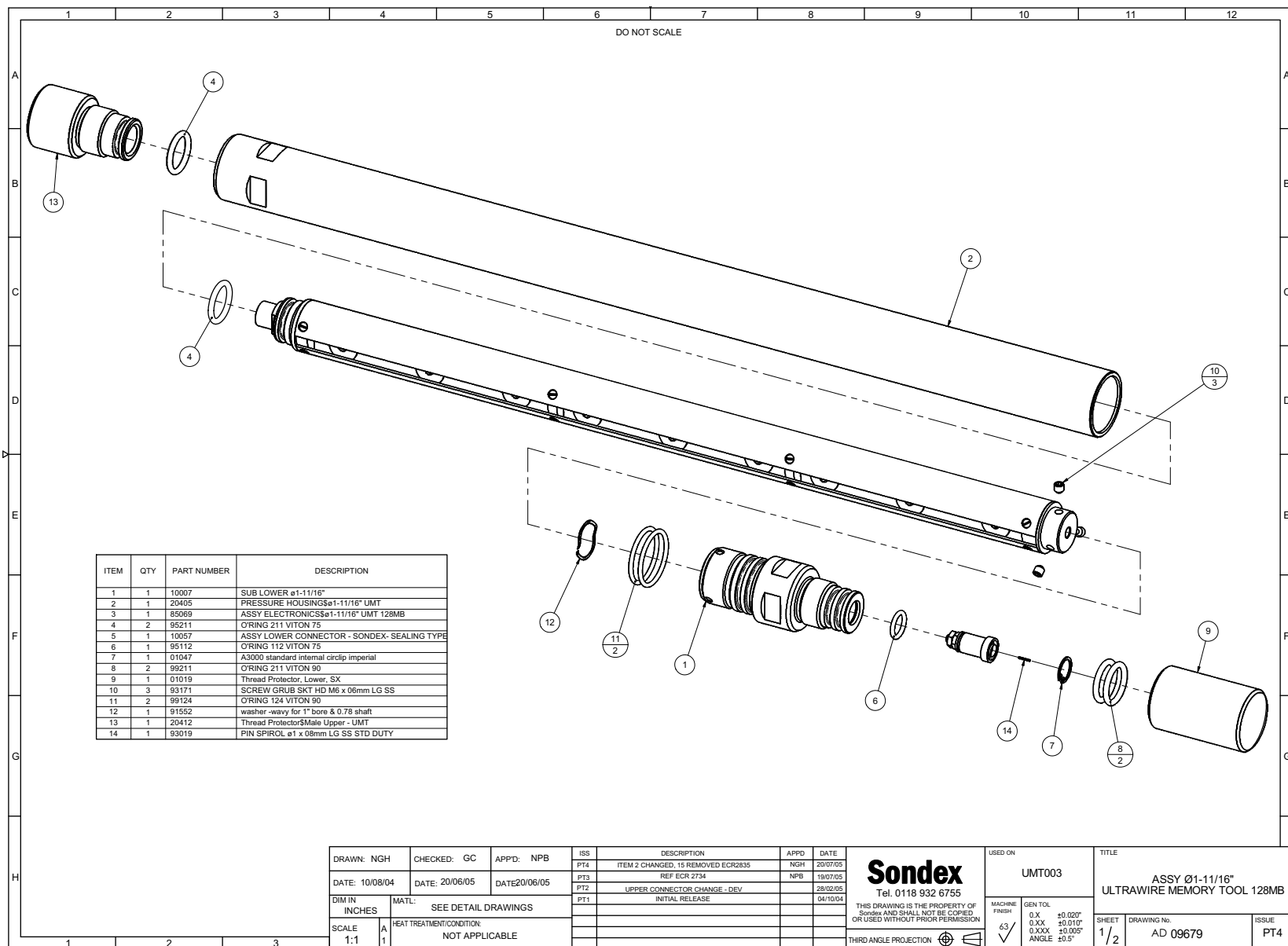

DRAWN: NGH	CHECKED: GC	APPD: NPB	ISS	DESCRIPTION	APPO	DATE	USED ON	TITLE
DATE: 10/08/04	DATE: 20/06/05	DATE: 20/06/05	PT4	ITEM 2 CHANGED, 15 REMOVED ECR2635	NGH	20/07/03	UMT003	ASSY Ø1-11/16" ULTRAWIRE MEMORY TOOL 128MB
DIM IN INCHES			MATL:	SEE DETAIL DRAWINGS			THIS DRAWING IS THE PROPERTY OF SONDEX AND SHALL NOT BE COPIED OR USED WITHOUT PRIOR PERMISSION	
SCALE 1:1			HEAT TREATMENT/CONDITION: NOT APPLICABLE			MACHINE FINISH 63		
						GEN TOL 0.X ±0.020" 0.XX ±0.010" 0.XXX ±0.005" ANGLE ±0.5°		
						THIRD ANGLE PROJECTION		
						SHEET 1/2 DRAWING No. AD 09679 ISSUE PT4		

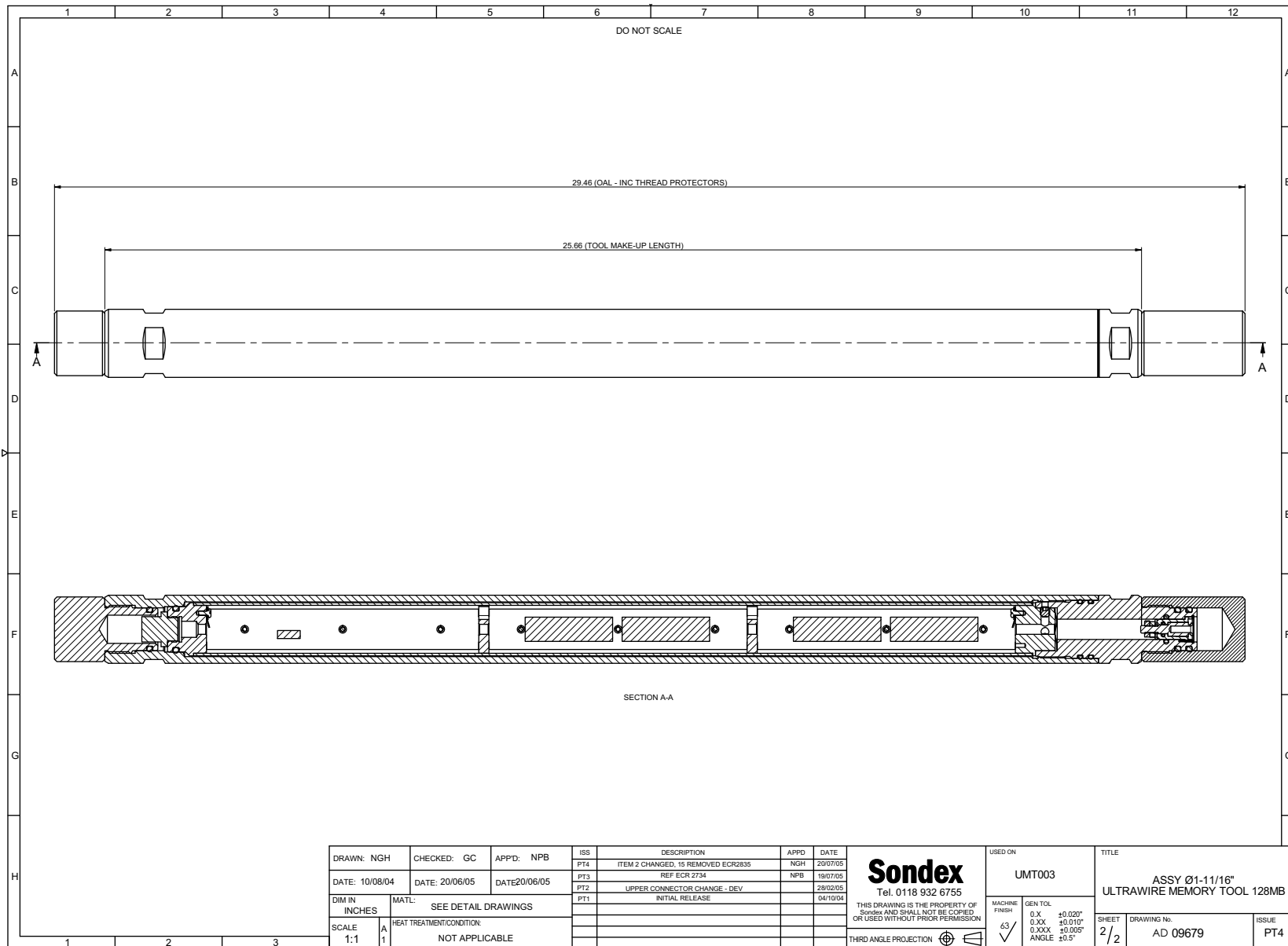

DRAWN: NGH		CHECKED: GC		APPD: NPB		ISS	DESCRIPTION	APPO	DATE	<b>Sondex</b> Tel. 0118 932 6755 <small>THIS DRAWING IS THE PROPERTY OF SONDEX AND SHALL NOT BE COPIED OR USED WITHOUT PRIOR PERMISSION</small> THIRD ANGLE PROJECTION	USED ON		TITLE			
DATE: 10/08/04		DATE: 20/06/05		DATE: 20/06/05		PT4	ITEM 2 CHANGED, 15 REMOVED ECR2835	NGH	20/07/05		UMT003		ASSY Ø1-11/16" ULTRAWIRE MEMORY TOOL 128MB			
DIM IN INCHES		MATL: SEE DETAIL DRAWINGS				PT3	REF ECR 2734	NPB	19/07/05		MACHINE FINISH		SHEET	DRAWING No.	ISSUE	S W
SCALE 1:1		HEAT TREATMENT/CONDITION: NOT APPLICABLE				PT2	UPPER CONNECTOR CHANGE - DEV		28/02/05		GEN TOL 0.X ±0.020" 0.XX ±0.010" 0.XXX ±0.005" ANGLE ±0.5°		2/2	AD 09679	PT4	
						PT1	INITIAL RELEASE		04/10/04	43 ✓						

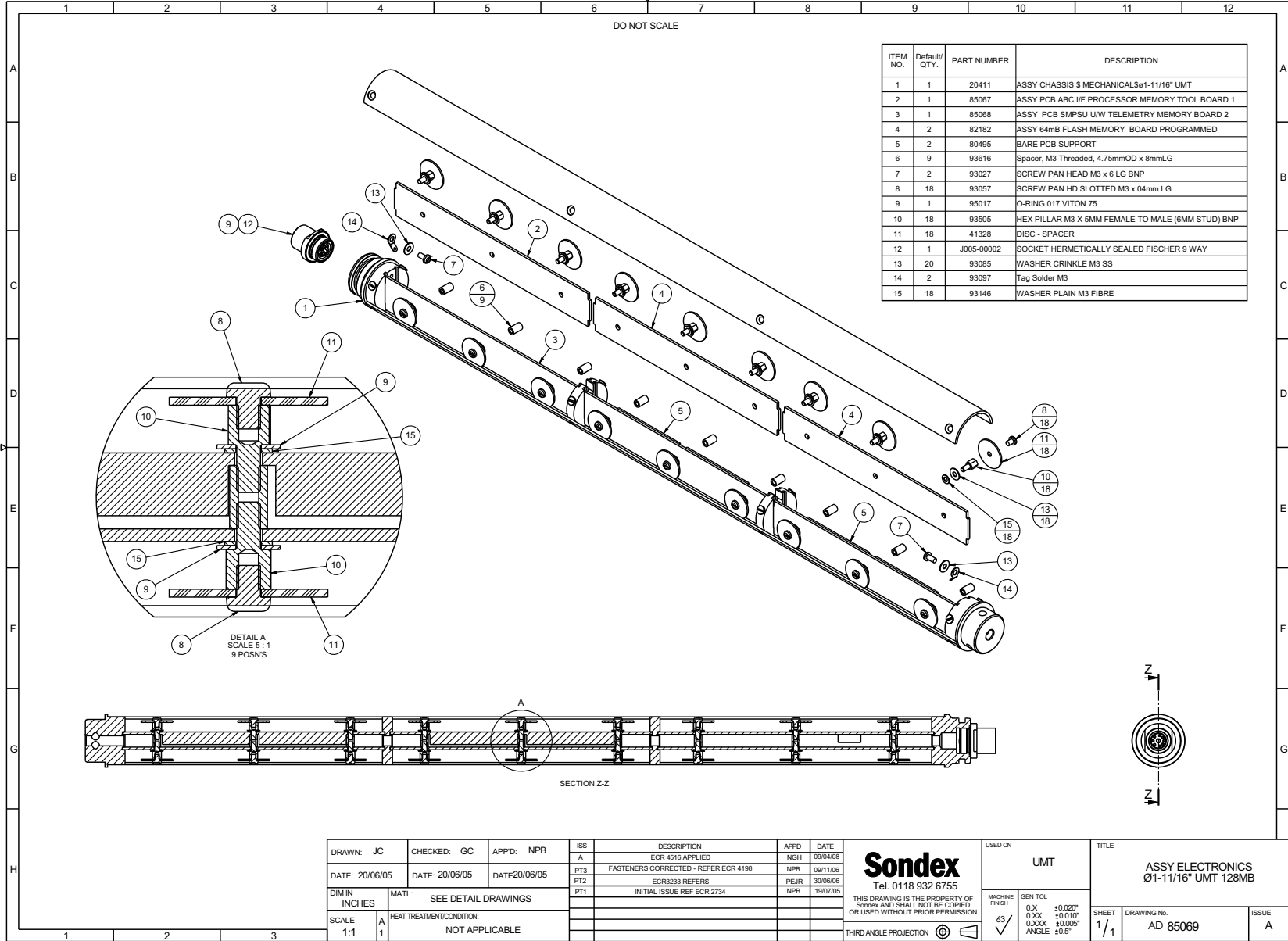

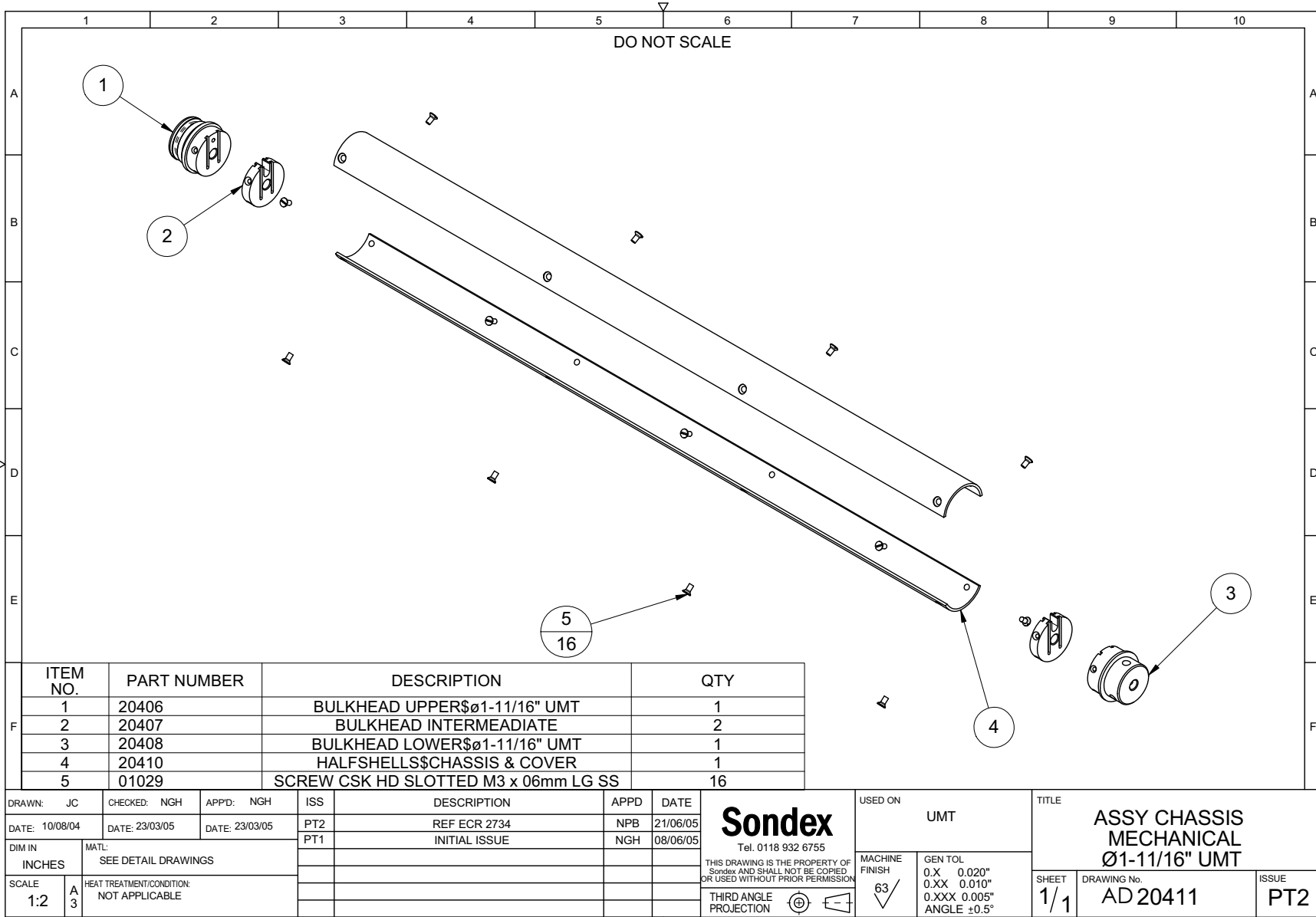

ITEM NO.	PART NUMBER	DESCRIPTION	QTY
1	20406	BULKHEAD UPPER\$Ø1-11/16" UMT	1
2	20407	BULKHEAD INTERMEADIATE	2
3	20408	BULKHEAD LOWER\$Ø1-11/16" UMT	1
4	20410	HALFSHELLS\$CHASSIS & COVER	1
5	01029	SCREW CSK HD SLOTTED M3 x 06mm LG SS	16

DRAWN: JC	CHECKED: NGH	APPD: NGH	ISS	DESCRIPTION	APPD	DATE	USED ON	TITLE
DATE: 10/08/04	DATE: 23/03/05	DATE: 23/03/05	PT2	REF ECR 2734	NPB	21/06/05	UMT	ASSY CHASSIS MECHANICAL Ø1-11/16" UMT
DIM IN INCHES			PT1	INITIAL ISSUE	NGH	08/06/05	MACHINE FINISH	
MATERIAL: SEE DETAIL DRAWINGS							63	GEN TOL
SCALE 1:2	A 3	HEAT TREATMENT/CONDITION: NOT APPLICABLE						0.X 0.020"
								0.XX 0.010"
								0.XXX 0.005"
								ANGLE ±0.5°
								SHEET 1/1
								DRAWING No. AD 20411
								ISSUE PT2
								SW

B-5

**Ultrawire™ Memory Tool**

**UMT003**

This document contains proprietary information. Copyright © 2006-2008 Sondex. All rights reserved.

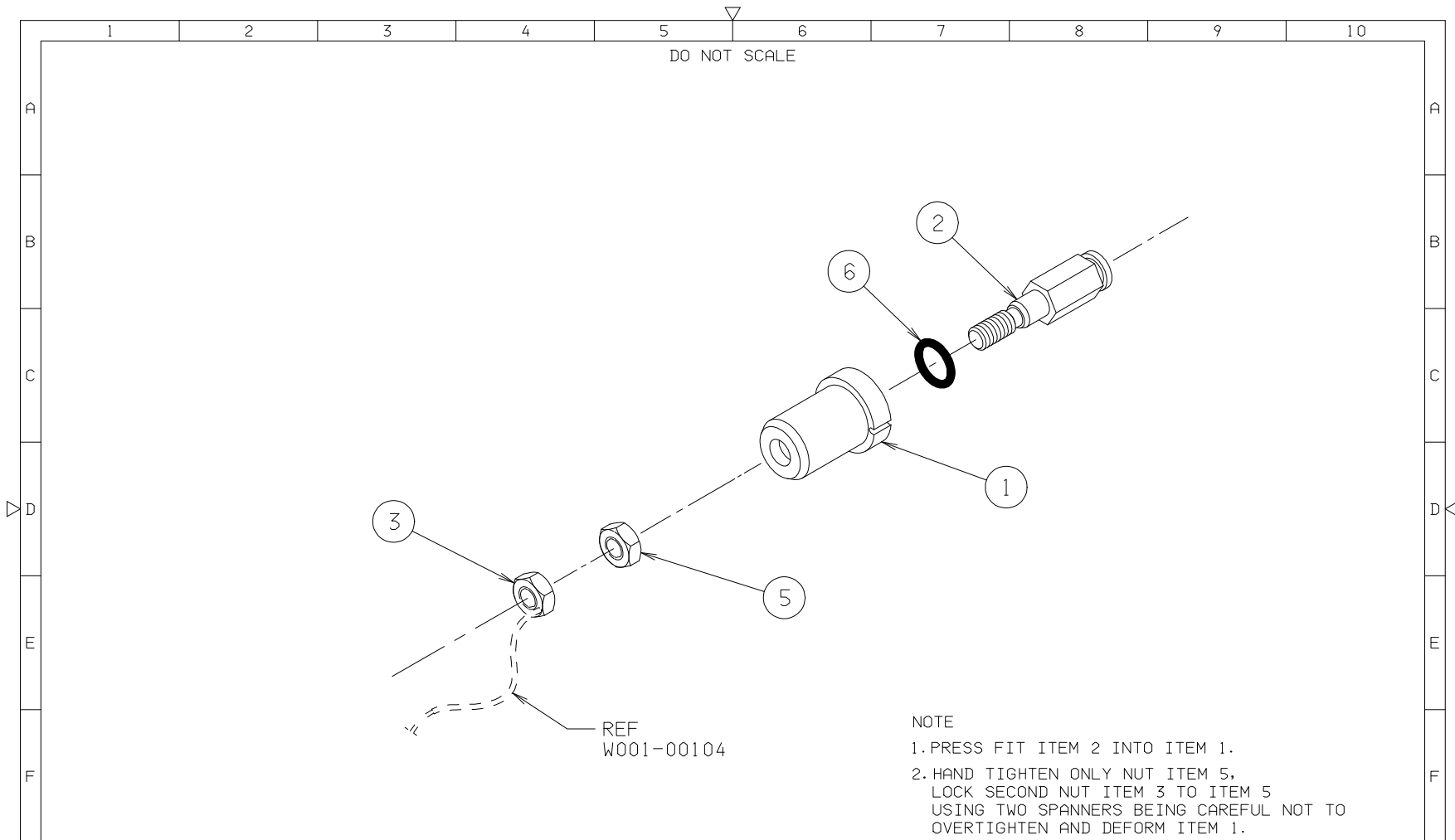

NOTE  
 1. PRESS FIT ITEM 2 INTO ITEM 1.  
 2. HAND TIGHTEN ONLY NUT ITEM 5,  
 LOCK SECOND NUT ITEM 3 TO ITEM 5  
 USING TWO SPANNERS BEING CAREFUL NOT TO  
 OVERTIGHTEN AND DEFORM ITEM 1.

ISS	DESCRIPTION	APPD	DATE	<p style="text-align: center;"><b>Sondex</b></p> <p style="text-align: center;">Tel. 0118 932 6755</p> <p style="text-align: center;">THIS DRAWING IS THE PROPERTY OF          Sondex AND SHALL NOT BE COPIED          OR USED WITHOUT PRIOR PERMISSION</p> <p style="text-align: center;">THIRD ANGLE PROJECTION</p>	MACHINE FINISH	USED ON	TITLE	
D	REF ECR 2653	GC	22/06/05		63/	COM	ASSY CONNECTOR LOWER SONDEX SEALING TYPE	
C	REF ECR 2382 ITEM 4 REMOVED	NPB	14/01/05		GEN TOL 0. X ±0.020" 0. XX ±0.010" 0. XXX ±0.005" ANGLE ±0.5°	SHEET 1/1	DRAWING No. 10057	
B	REFER TO ECR 1524	DJF	06/06/03					ISSUE D
A	INITIAL RELEASE							
DRAWN JDR DATE 07-10-98 DIM IN INCHES SCALE 1:1	CHECKED AJG DATE 04-01-99	APPROVED DJF DATE 21-01-99	MATL: SEE DETAIL DRAWINGS					

SONDEX FM No: F0024

PARTS LISTING					
Part:	Issue:		Drawn:	Checked:	Approved:
10057	D		JDR	AJG	DJF
Description:			Date:	Date:	Date:
Assy Connector Lower SX Sealing Type			07/10/1998	04/01/1999	21/01/1999

CHANGE HISTORY					RELATED DOCUMENTS		
Iss	Date	Remarks	Chkd	Appr	# Documents	Issue	Notes
A	21/01/1999	Initial Release	AJG	DJF	01 AD10057	D	ASSEMBLY DRG
B	--/--	DESIGN MOD TO PREVENT STRAY BURR SHORTING TOOL, ECR 1046					
C	11/05/2003	Re: ECR 1527	DJF	DJF			
D	06/01/2005	Re: ECR 2382	NPB	NPB			

PARTS LIST							
Item	Part No.	Issue	Description	Component Value	Qty	Units	Remarks
001	00690	E	Insulator Lower Sub		1	ea	
002	00695	C	Pin Hex Female Lower		1	ea	
003	10016	B	Nut, Hex, 10-32UNF, Brass/Nickel Plate, (with wire hole)		1	ea	
005	93133	-	Nut Hex 10-32 BNP		1	ea	
006	95009	-	O Ring Viton 75 Type 009		1	ea	

(AR = As Required)



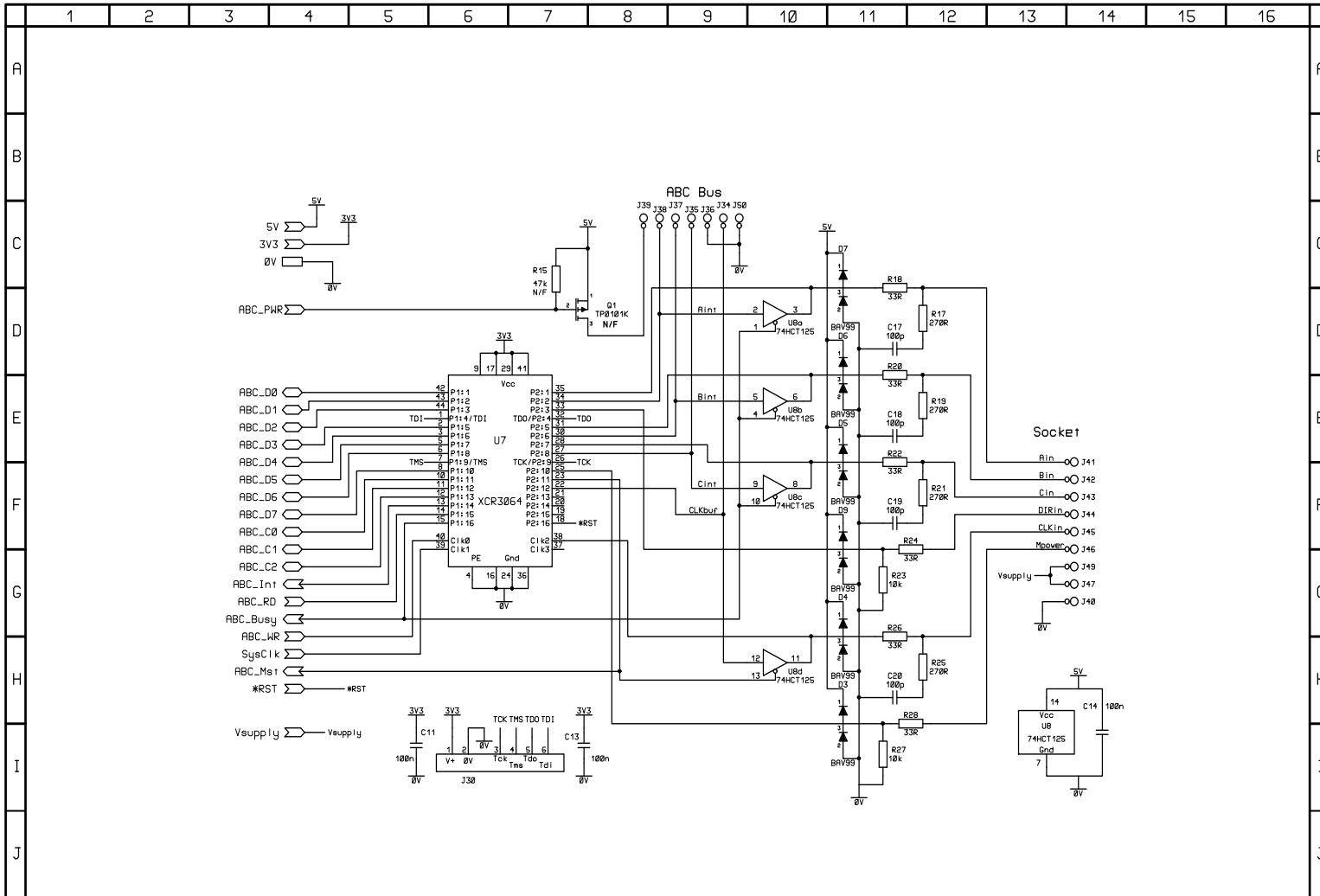

ISS. REV.	ECR NUMBER, REMARKS	CHKD	APPR	DATE	SONDEX LTD	TITLE	DRAWING NUMBER	ISSUE	REVISION
PT1	Prototype			May 03	Ford Lane, Bramshill	UMT Board 1	CD-85062	E	00
PT2	Initial Release			27/10/03	Hook, Hampshire	ABC Bus Interface			
PT3	Macronix Module Mod			12/09/03	RG27 0RH, England	Circuit Diagram			
D 00	New Release	RH	RH	21/09/05	TEL: +44 (0) 118 932 6755		DRAWN KW	CHECKED RH	APPROVED RH
E 00	ECR4631 01/R15 C1 N/F; C3/R6 Value change	KRW	KRW	23/04/07	FAX: +44 (0) 118 932 6704		DATE 24/10/03	DATE 22/09/05	DATE 22/09/05
This document contains proprietary information. Copyright 2003 © Sondex Ltd.							SHEET 1	OF 3	

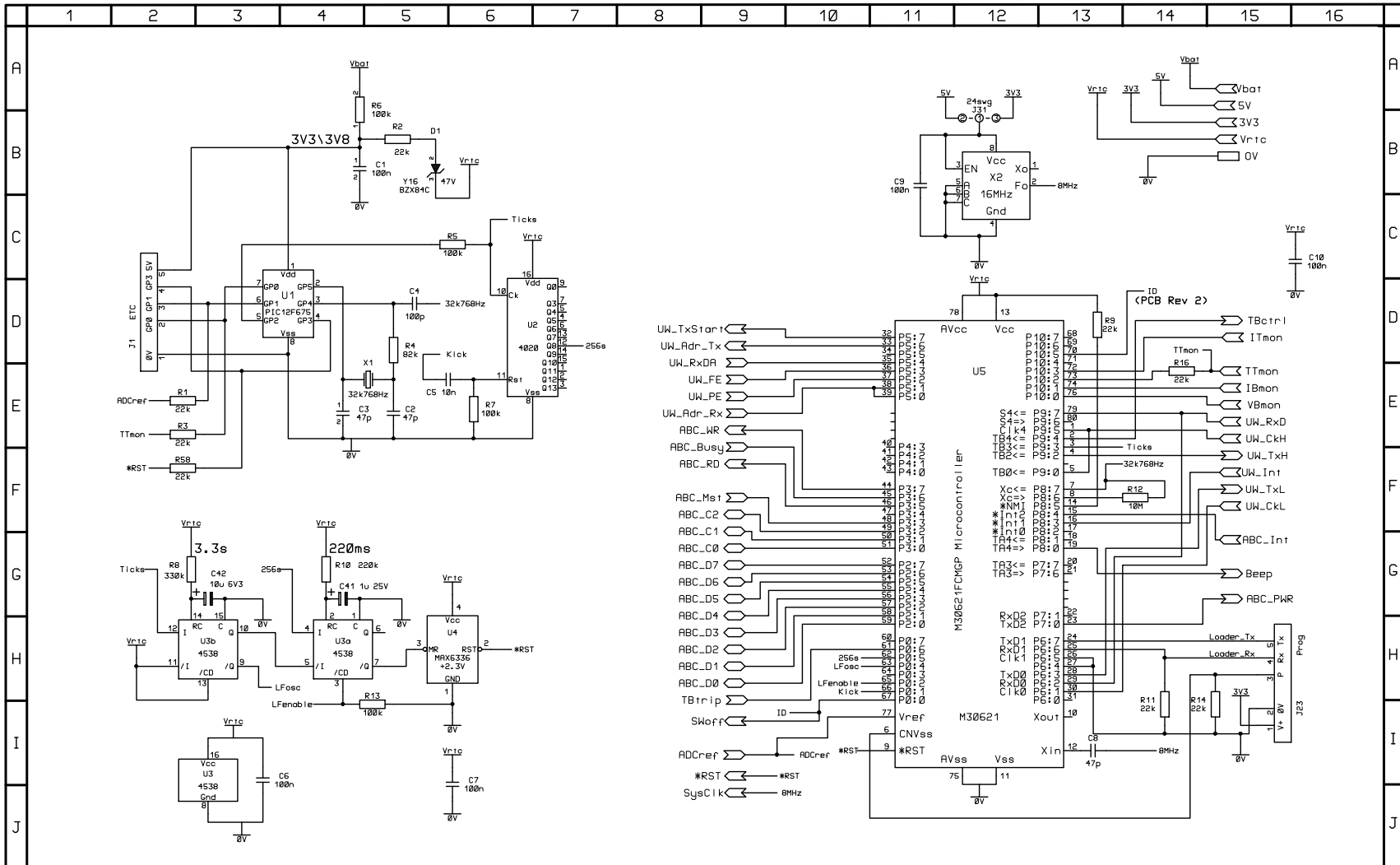

ISS.	REV.	ECR NUMBER, REMARKS	CHKD	APPR	DATE	SONDEX LTD		UMT Board 1		DRAWING NUMBER		ISSUE	REVISION
PT1		Prototype			May 03	Ford lane, Bramshill		Processor		CD-85062		E	00
PT2		Initial Release			27/10/03	Hook, Hampshire		Circuit Diagram		DRAWN		CHECKED	APPROVED
PT3		Macronix Module Mod				RG27 0RH, England				KW		RH	
D	00	New Release	RH	RH	21/09/05	TEL: +44 (0)118 932 6755				DATE		DATE	DATE
E	00	ECR4631 01/R15 C1 N/F; C3/R6 Value change	KRW	KRW	23/04/07	FAX: +44 (0)118 932 6704				12/09/05		00/00/00	22/09/05
						This document contains proprietary information. Copyright 2005 © Sondex Ltd.						SHEET 2 OF 3	

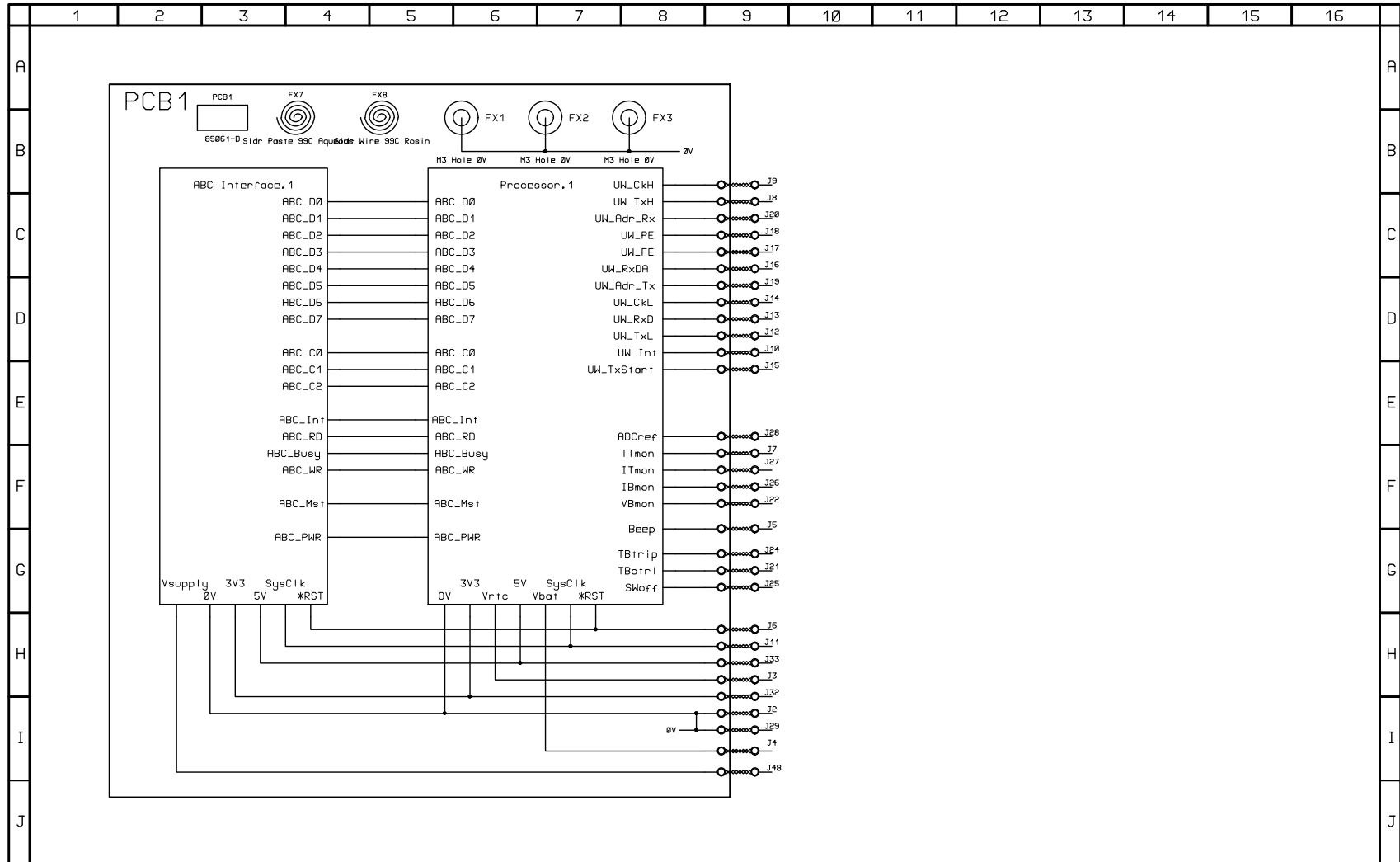

ISS.	REV.	ECR NUMBER, REMARKS	CHKD	APPR	DATE	TITLE	DRAWING NUMBER	ISSUE	REVISION	
PT1		Prototype			May 03	<b>SONDEX LTD</b> FORD LANE, BRAMSHILL HOOK, HAMPSHIRE RG27 0RH, ENGLAND TEL: +44 (0) 118 932 6755 FAX: +44 (0) 118 932 6704	CD-85062	E	00	
PT2		Initial Release			27/10/03		DRAWN	CHECKED	APPROVED	
							KW	DJ	RH	
D	00	New Release	RH	RH	21/09/05		DATE	DATE	DATE	
E	00	ECR4631 01/R15 C1 N/F; C3/R6 Value change	KRW	KRW	23/04/07		24/10/03	27/10	22/09/05	
This document contains proprietary information. Copyright 2003 © Sondex Ltd.							SHEET	3	OF	3

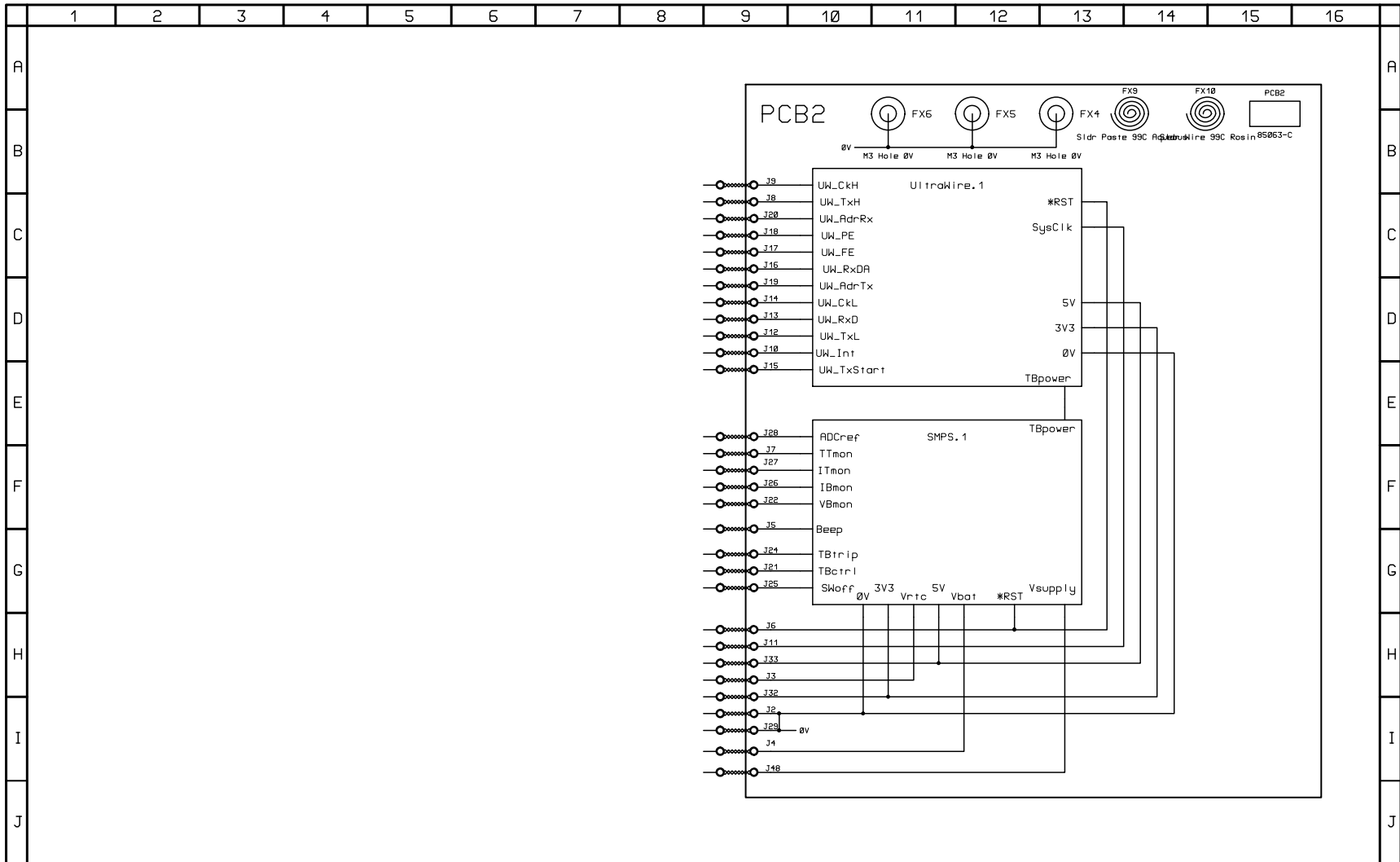

ISS.	REV.	ECR NUMBER, REMARKS	CHKD	APPR	DATE	SONDEX LTD	TITLE	DRAWING NUMBER	ISSUE	REVISION	
PT1		Prototype			May 03	FORD LANE, BRAMSHILL	Memory Tool Board 2	CD-85064	A	00x	
PT2		Initial Release			27/10/03	HOOK, HAMPSHIRE	Interconnections	DRAWN	CHECKED	APPROVED	
PT3		SMPS updated U18 added	DJ	KW	23/06/04	RG27 0RH, ENGLAND	Circuit Diagram	KW	DJ	KW	
PT4		ECR2153. Pt No attributes L1,L2,L3 corrected	DJ	KRW	09/08/04	TEL: +44 (0) 118 932 6755		DATE	DATE	DATE	
PT5		ECR3504 Add U12 to P/List	KRW	KRW	21/02/05	FAX: +44 (0) 118 932 6704		24/10/03	22/05/04	23/05/04	
A	00	ECR3959 C23 was SOT	KW	KW	12/07/06	This document contains proprietary information. Copyright 2003 © Sondex Ltd.			SHEET	1	OF 3

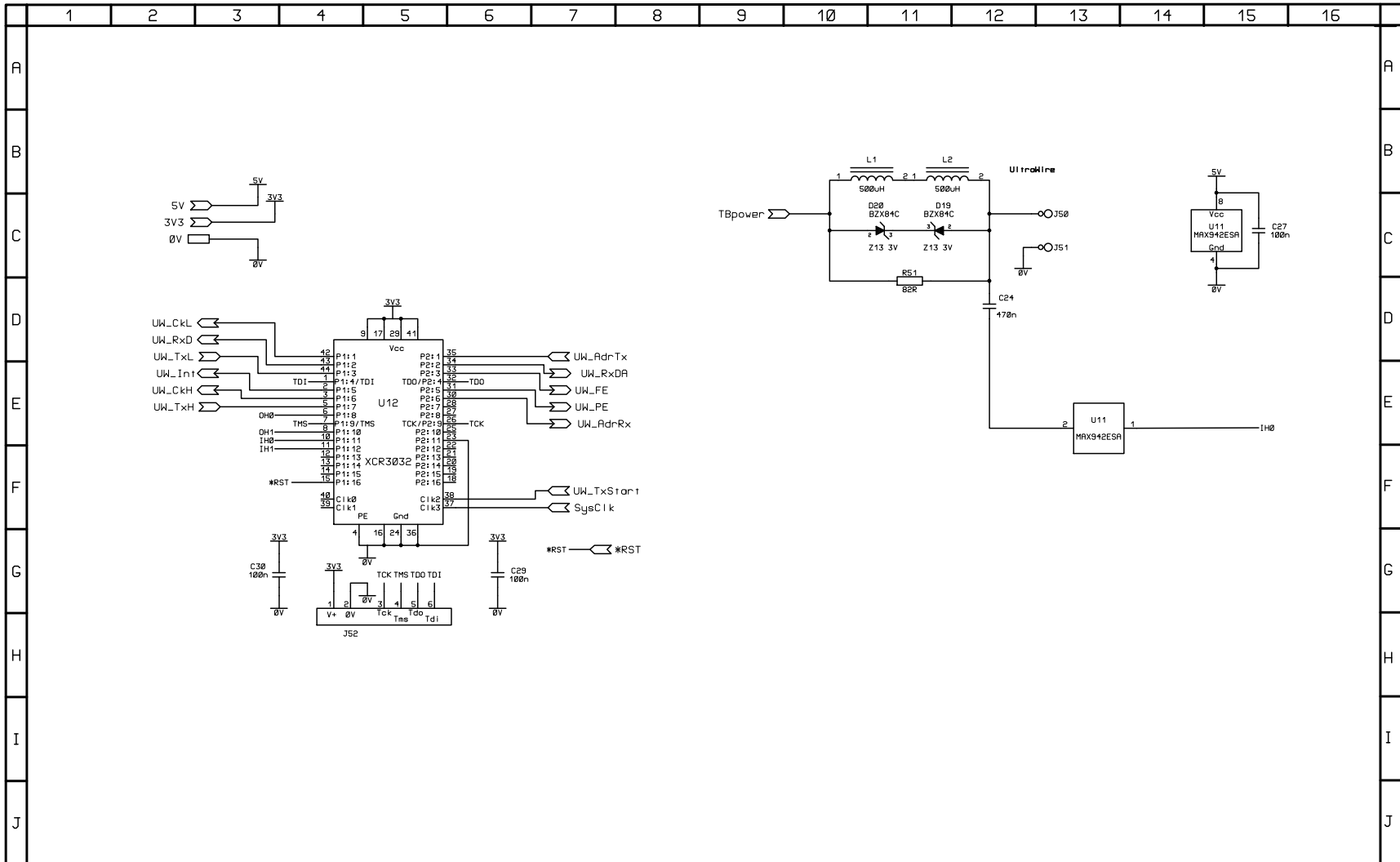

ISS.	REV.	ECR NUMBER, REMARKS	CHKD	APPR	DATE	SONDEX LTD	TITLE	DRAWING NUMBER	ISSUE
PT1		Prototype			May 03	Ford lane, Bramshill	Memory Tool Board 2	CD-85064	A 00x
PT2		Initial Release			27/10/03	Hook, Hampshire	Ultrawire		
PT3		SMPS updated U18 added	DJ	KW	23/06/04	RG27 0RH, England	Circuit Diagram		
PT4		ECR2153. P1 No attributes L1,L2,L3 corrected	DJ	KRW	09/08/04	TEL: +44 (0) 118 932 6755			
PT5		ECR3604 Add U12 to P/List	KRW	KRW	21/02/06	FAX: +44 (0) 118 932 6704			
A	00	ECR3959 C23 was S0T	KW	KW	12/07/06	This document contains proprietary information. Copyright 2003 © Sondex Ltd.		SHEET 2 OF 3	

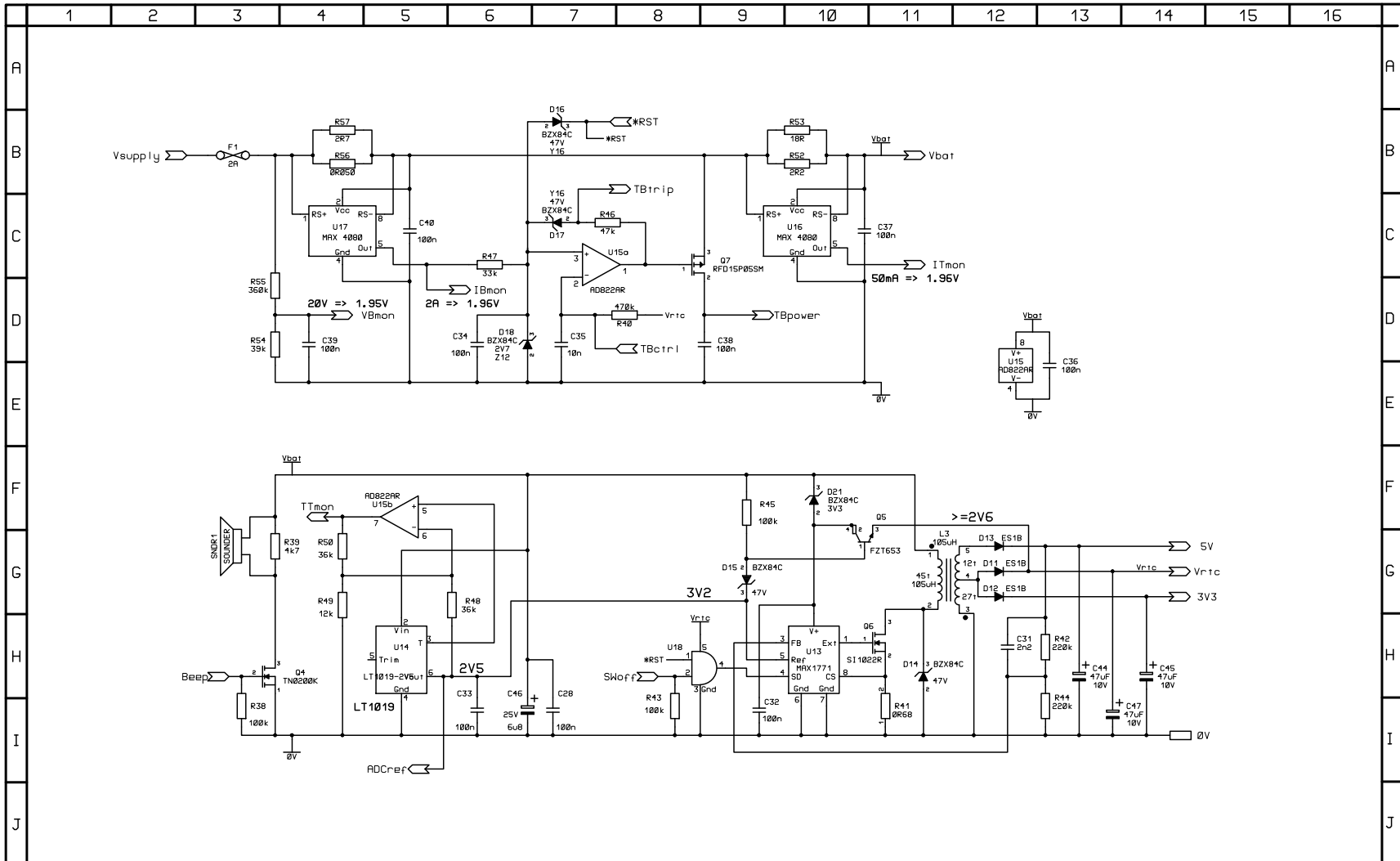

ISS.	REV.	ECR NUMBER, REMARKS	CHKD	APPR	DATE	SONDEX LTD			TITLE			DRAWING NUMBER	ISSUE	REVISION
PT1		Prototype			May 03	Ford lane, Bramshill			Memory Tool Board 2			CD-85064	A	00x
PT2		Initial Release			27/10/03	Hook, Hampshire			SMPS					
PT3		SMPS updated U18 added	DJ	KW	23/06/04	RG27 0RH, England			Circuit Diagram					
PT4		ECR2153. Pt No attributes L1,L2,L3 corrected	DJ	KRW	09/09/04	TEL: +44 (0) 118 932 6755								
PT5		ECR3604 Add U12 to P/List	KRW	KRW	21/02/06	FAX: +44 (0) 118 932 6704								
A	00	ECR3959 C23 was S0T	KW	KW	12/07/06	This document contains proprietary information. Copyright 2003 © Sondex Ltd.						SHEET 3	OF 3	

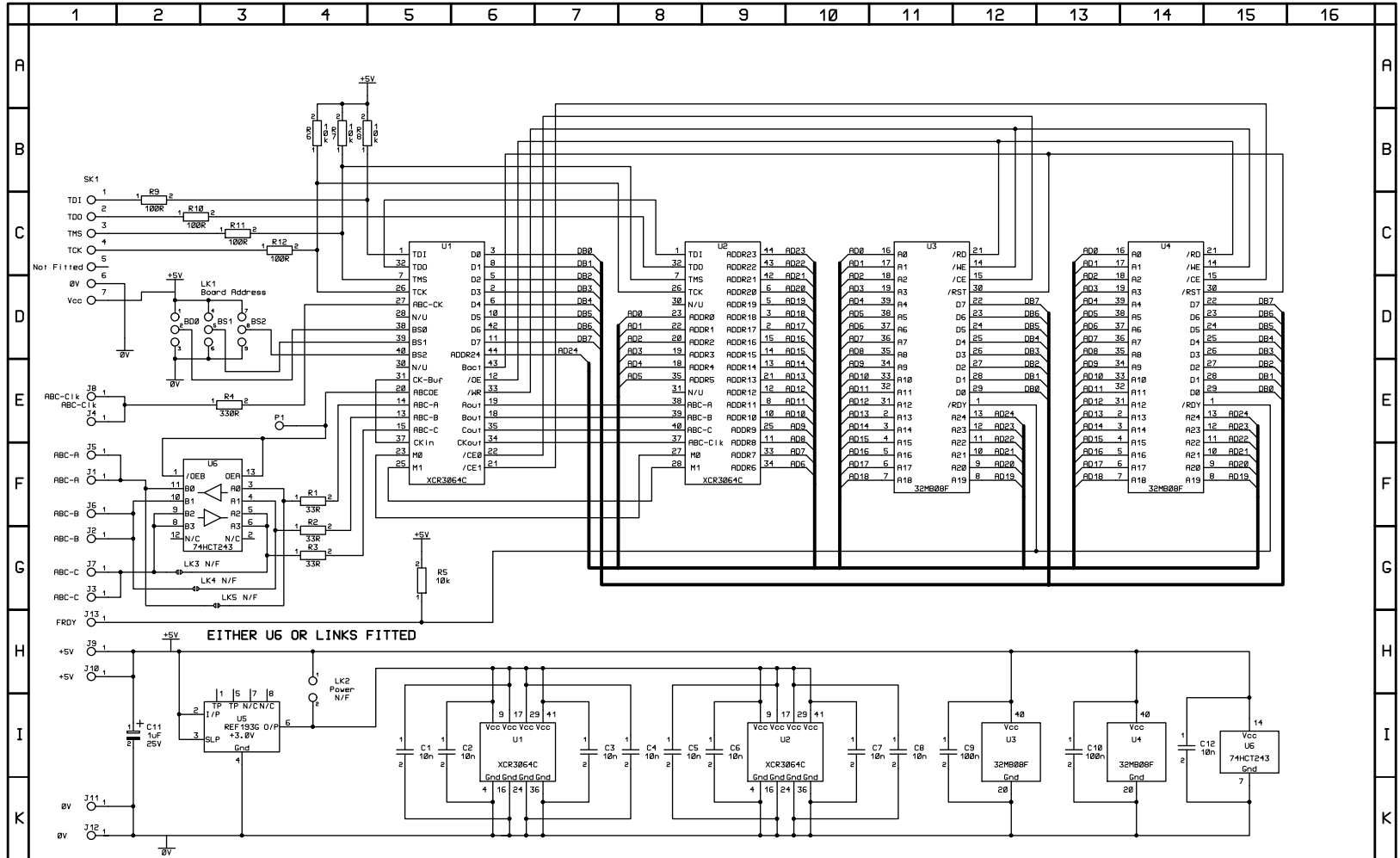

ISS. REV.	CHANGE DETAILS	DATE	TITLE	DRAWING NUMBER	ISSUE	REVISION	
F 00	ECR5427 LK3,4,5 Not Fitted	20/05/08	<b>SONDEX LTD</b> FORD LANE, BRAMSHILL, HOOK, HAMPSHIRE, RG27 0RH, ENGLAND TEL: +44 (0) 118 932 6755 FAX: +44 (0) 118 932 6704	CD-80693	F	00	
B	ECR771. Diagram Issue raised to match New PCB Issue	11/3/01		64MB Flash Memory Board	DRAWN PEJR	CHECKED DJ	APPROVED PEJR
B 01	C11 assy note added. SK1 P1 No changed	30/11/01		Circuit Diagram	DATE 05/12/00	DATE 30/11/01	DATE 30/11/01
C	ECR4156 U1 & U2 were 5V, U5 & U6 added	03/11/06					
D 00	ECR4556 U3, U4 was fitted	05/04/07					
E 00	ECR5154 Links added; 5V added to SK1	10/12/07	THIS DRAWING IS THE PROPERTY OF SONDEx Ltd AND SHALL NOT BE COPIED OR USED WITHOUT PRIOR PERMISSION	SHEET 1	OF 1		

## APPENDIX C UMT SOUND LIBRARY

This manual contains a range of sounds that can be expected during operation of the UMT.



To listen to a sound, click to the Attachment tab on the far lefthand side of the screen. The attachment tab looks like the picture shown on the left.

If it is not shown, go to View - Navigation Tabs on the menubar.

Once the Attachment Tab is selected, the following navigation pane is shown (see picture on the right).

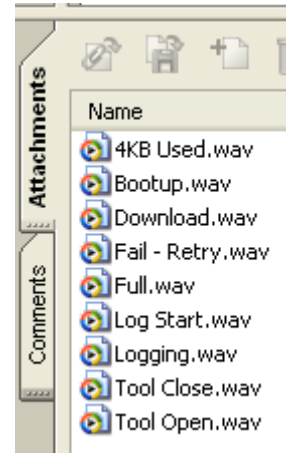

The files are in WAV format, which can be played in most Media Players, like Windows Media Player.

Windows Media Player opens automatically when the file is opened, of the program can be opened via:

Start Menu - Programs - Accessories - Entertainment (depending on operating system).

The following sounds are available:

Sound Name	Occurs
Bootup	During boot up.
Log Start	When logging commences.
Logging	During logging (general sound).
4KB Used	This is heard every time 4kB of memory is used.
Tool Open	When Tool Open command is sent.
Tool Close	When Tool Close command is sent.
Fail - Retry	When an Open or Close fails and is retried.
Full	When tool memory is full.
Download	When memory downloading commences.