

# SLICKLINE ASSISTANT WORKBOOK

## IMPORTANT NOTE:

1. Your point of reference to complete this workbook may be obtained from the following
  - Training Manual and any other training materials provided together with this workbook
  - Your Trainer, Assessor (Slickline Operator), Verifier (FSM) or senior colleagues
  - SOP / Quality Procedures & Processors
2. The completion of this Workbook is a joint effort and responsibility between you and your assessor therefore you have the obligation to request from your assessor to be assessed upon your completion of each topic
3. The completion of this Workbook is part of the MANDATORY requirements which you must fulfill to qualify for a promotion
4. Your training program is mostly self-driven, including this Workbook. It requires individual initiatives, dedication and commitment to complete the process.

<b>NAME</b>	<b>SHAFIQ EZANEE BIN SUHAIDI</b>
<b>DATE OF JOIN</b>	<b>6 MARCH 2023</b>
<b>CONTACT NO.</b>	<b>01112900120</b>
<b>RECEIVED DATE</b>	
<b>DATE COMPLETED</b>	



## B. SURFACE EQUIPMENT

### B.1. STUFFING BOX

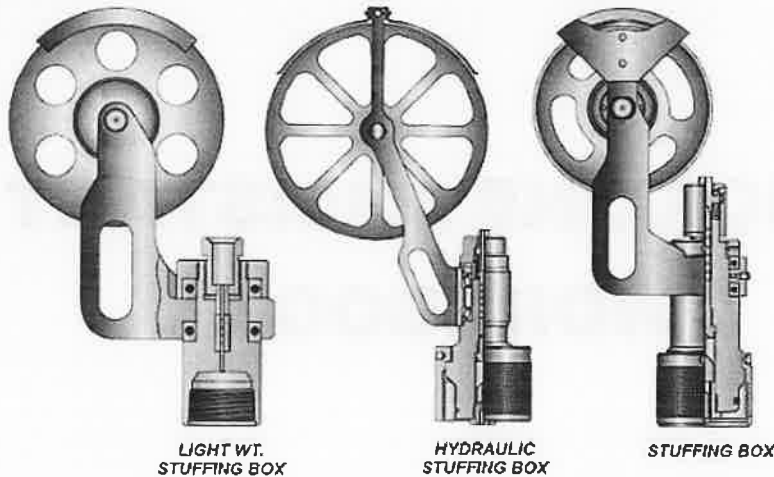

#### What is Stuffing Box

- Stuffing box is to ensure sealing off around moving or stationary solid wireline at the upper end of the lubricator during wireline operations

#### What is the purpose of stuffing Box

- Allows the wireline to enter the well under pressure and provide a seal should be wireline break and be blow out of packing. Is a primary pressure barrier.

#### How to operate Stuffing Box

- Consists of a chamber which contains packing with an external adjustable nut.
- Wire passes through the packing and the nut is hydraulically tightened to the point where leakage around the line, caused by well pressure, is reduced to a minimum.
- The ratio of the wire to sheave size is 1:120
- Packing nut and gland located at top of Stuffing Box can be adjusted to compress the packing and seal on wireline.
- Hydraulically controlled packing nuts are available – can use hand pump.
- Hydraulic Packing Nut assembly, includes a piston.
- When hydraulic pressure is applied to area above piston, piston is forced downward against force of spring
- This downward action of piston is transmitted to upper packing gland which cause packing to be squeezed around wireline



**What is maintenance required for Stuffing Box**

- Packing not worn out. sheave the correct size. Upper and lower glands packing check for wear, if worn oversized should replace. BOP plunger check for freedom and wear of vertical movement. Sheave stuff check for freedom of swivel movement. Sheave bearing check for free spinning. Sheave guard make sure tight and adjustable to close.

**What is safety precaution required for Stuffing Box**

- check the 'o' ring before use it

**What is potential hazard during handling Stuffing Box**

- back pain
- pinch point



**Draw & name each part of stuffing box**

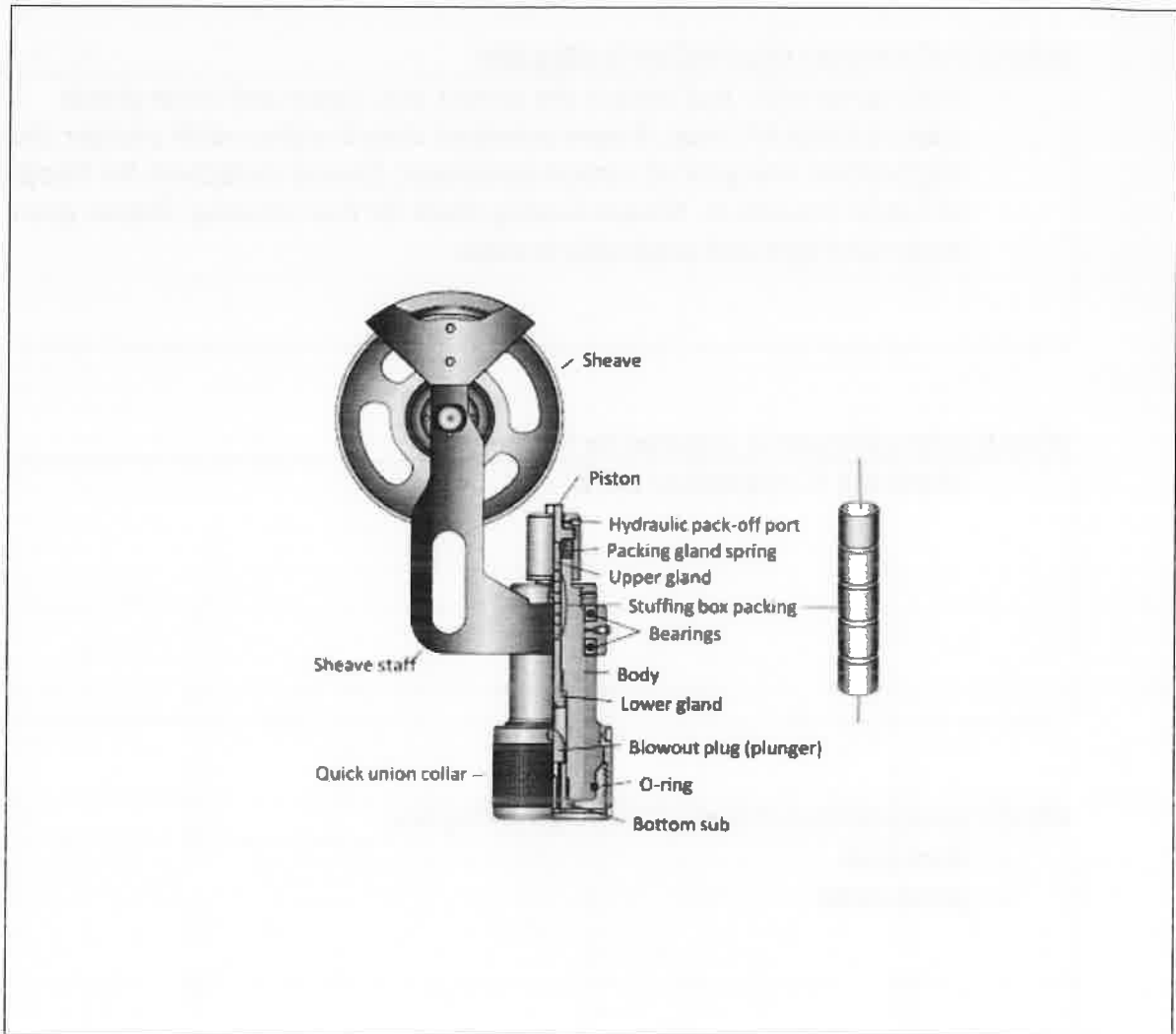



## **B.2. LUBRICATOR**

### **What is Lubricator**

- (Also known as risers) are a series of interconnected length of pipe

### **What is the purpose of Lubricator**

- To provide a space for the tool to be contained in under pressure, when opening and closing the wellhead.

### **How to operate Lubricator**

1. Primary Test Period (Low Pressure) – raise pressure to 300 psi +/- 20 psi
2. Hold pressure for a minimum of 5 minutes
3. Secondary Test Period (High Pressure) – raise pressure to maximum working pressure
4. Hold pressure for a minimum of 15 minutes

### **What is maintenance required for Lubricator**

1. General damage and corrosion
2. The condition of the needle valves on the lower sections. If necessary, redress or replace the valve
3. Visual inspection of the internal bore for corrosion and 'wire tracking' wear grooves

### **What is safety precaution required for Lubricator**

- lubricator should be enclosed in protective cage during use and transportation and stored in the transport frame



What is potential hazard during handling Lubricator

- back pain
- pinch point

Draw & name each part of Lubricator

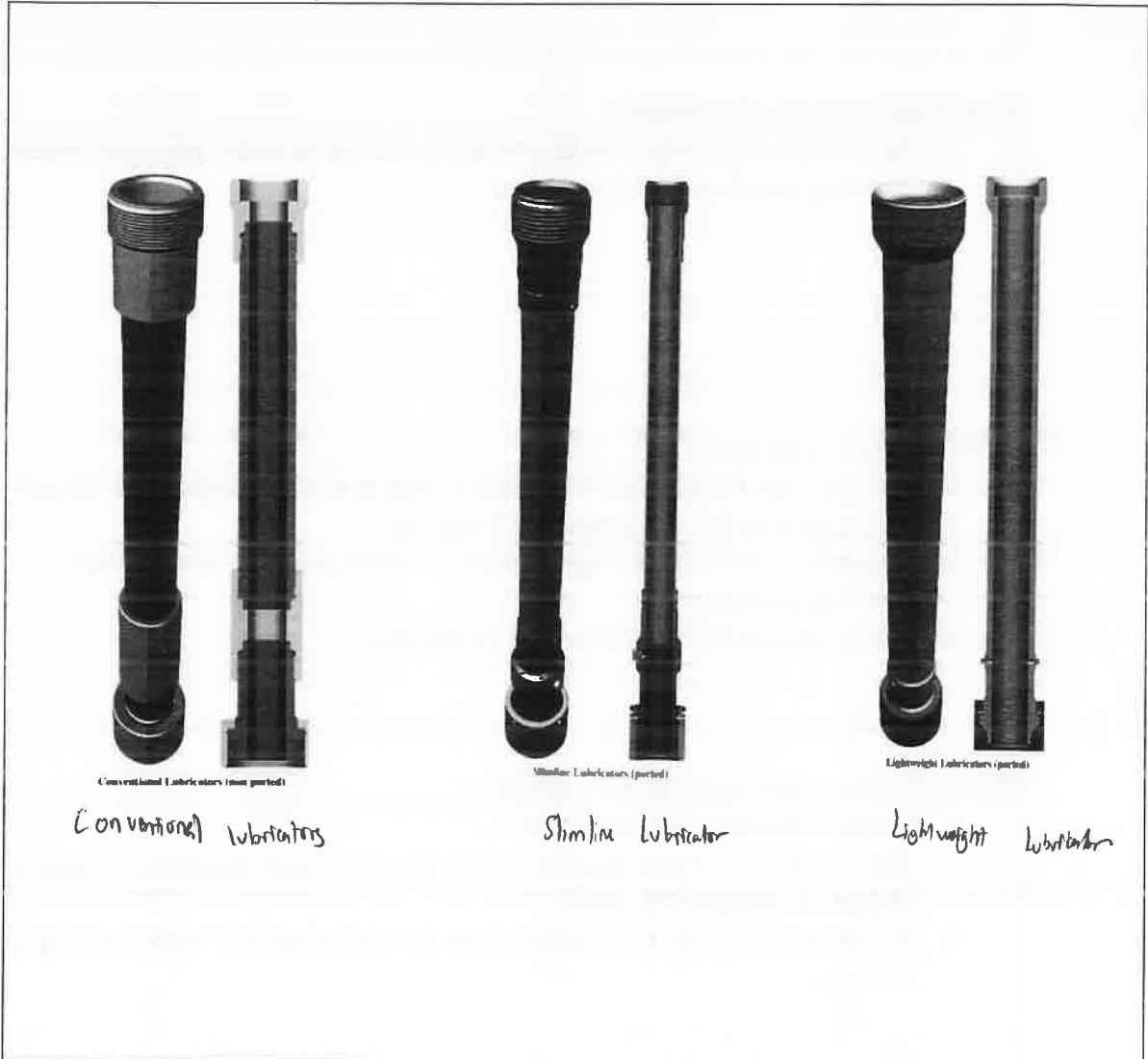



### B.3. BLOWOUT PREVENTER (BOP)

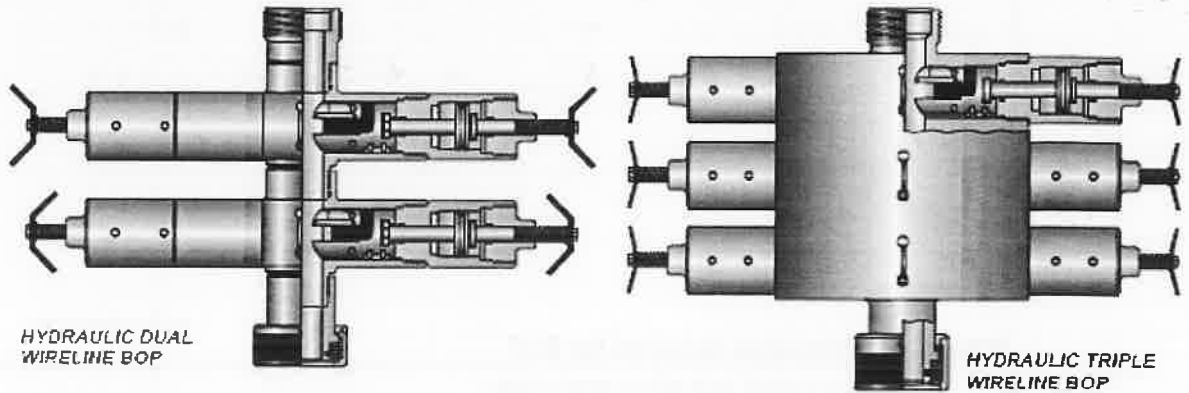

#### What is BOP

- A BOP (also known as a wireline valve) is installed between the tree connection and lower lubricator section.

#### What is the purpose of BOP

1. Enable the well pressure to be isolated without cutting the wire by closing the master valve
2. permit assembly of the wireline cutter above the BOP rams and dropping it if the tool string becomes stuck in the well
3. allow slickline work under the well pressure on surface equipment, while wire in the wellbore

#### How to operate BOP

- With the rams open - Pressure to 150% of the working pressure
- With the rams closed - Pressure to 100% of the working pressure to test the ram seal against the wire diameter
- use blind rams rubber inserts on the sealing faces to seal with or without wire across the rams
- working pressure is 5,000 psi and test pressure is 10,000 psi



### What is maintenance required for BOP

- to be carried out after every job
- to be carried out once a year
- to be carried out every 5 years

### What is safety precaution required for BOP

- ensure the rod has an enlarged diameter below the ram to prevent it from being blown out during testing

### What is potential hazard during handling BOP

- heavy equipment
- stay near during pressure test or function test



**Draw & name each part of BOP**

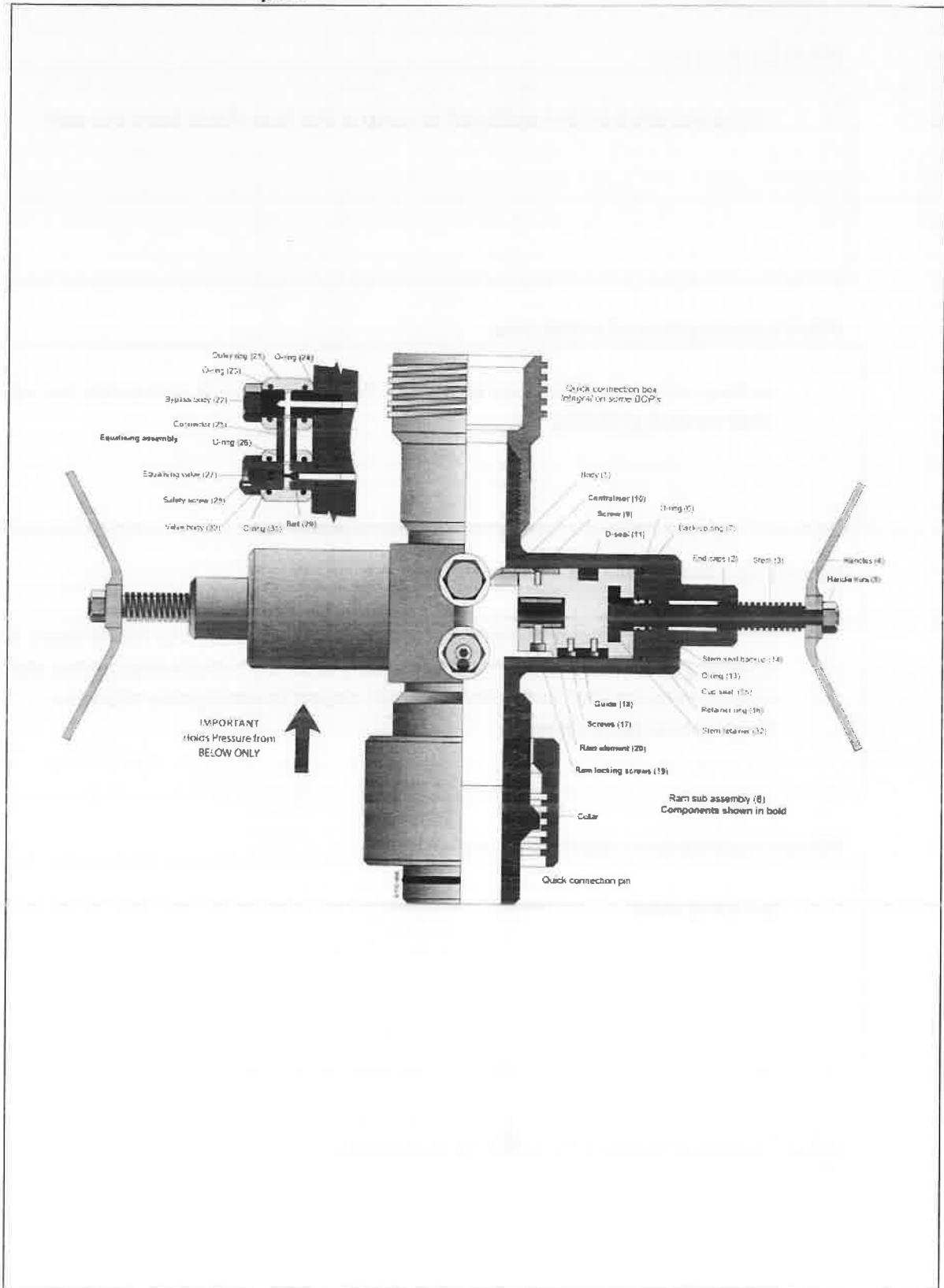



#### **B.4. X-MAS TREE**

What is x-mas tree

- valve installed on the wellhead to control the flow fluids from the well

What is the purpose of x-mas tree

- surface valve manifold used to control flow of well fluids and access for well intervention activities

How to operate x-mas tree

- Do not overtightened the valves during opening and closing. Many types have a shear pin between the handle and stem, valve's internal components use the master valve to shut in the flowing well, expect in emergency situation. Use swab or wing valves.

What is maintenance required for x-mas tree

- greasing valve

What is safety precaution required for x-mas tree



- always set time before and after open or close the valve. to make sure the valve fully open and fully close

What is potential hazard during handling x-mas tree

- line of fire
- flammable release

Draw & name each part of x-mas tree

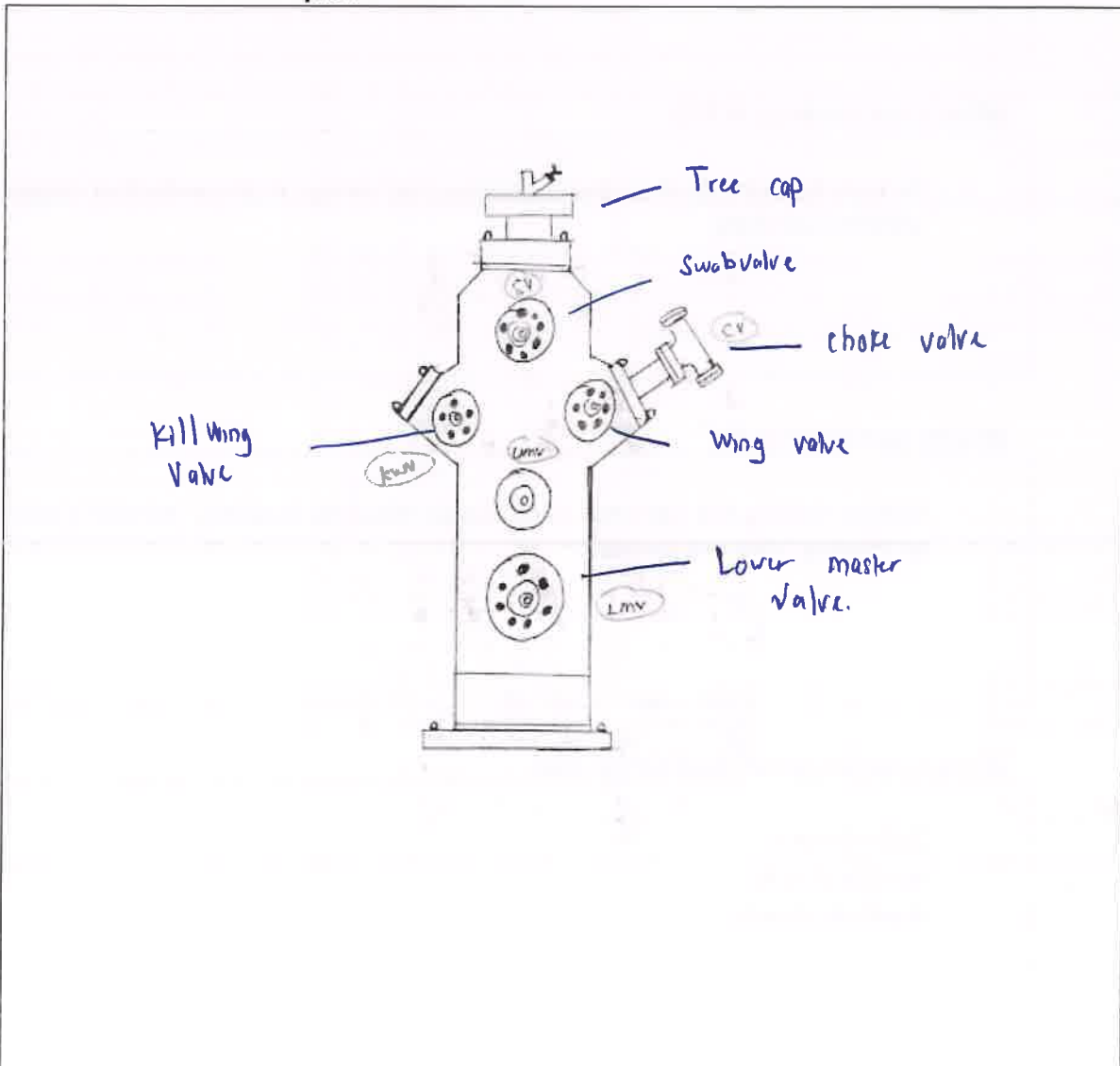



[Empty box for content]

**B.5. WIRELINE REEL SKID UNIT (RSU) / WINCH – SINGLE DRUM AND DOUBLE DRUM**

What is RSU

- RSU is real skid unit. also known as wireline unit or winch

What is the purpose of RSU

- To turn the wire drum to lower and rise tool strings in the wells that require wireline servicing.

How to operate RSU

- before starting the operator must decide whether to select “normal wireline” or logging “descent control”.

What is maintenance required for RSU

- Daily checks
- weekly checks
- monthly checks



**What is safety precaution required for RSU**

- make sure the counter wheel is free to rotate
- make sure the direction of rotation is correct
- make sure the cable is not kinked
- make sure rotation is being transmitted freely to the odometer

**What is potential hazard during handling RSU**

- the counter wheel is stuck to rotate
- the cable is kinked
- the direction of rotation is incorrect

**Draw & name each part of RSU**

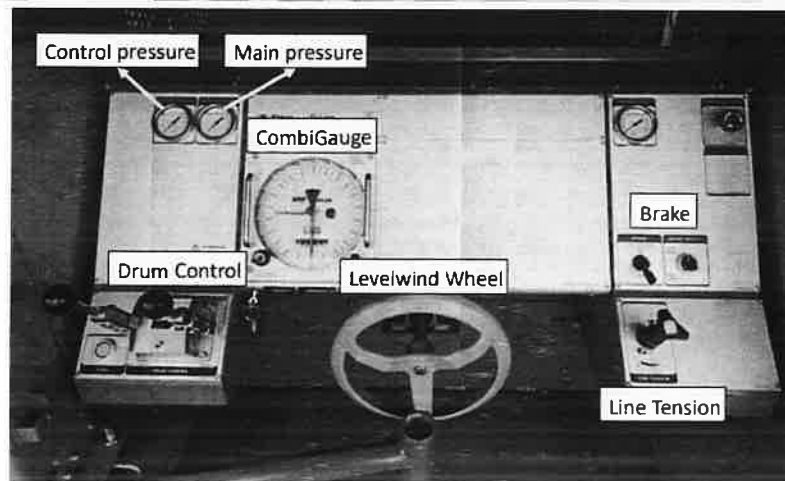
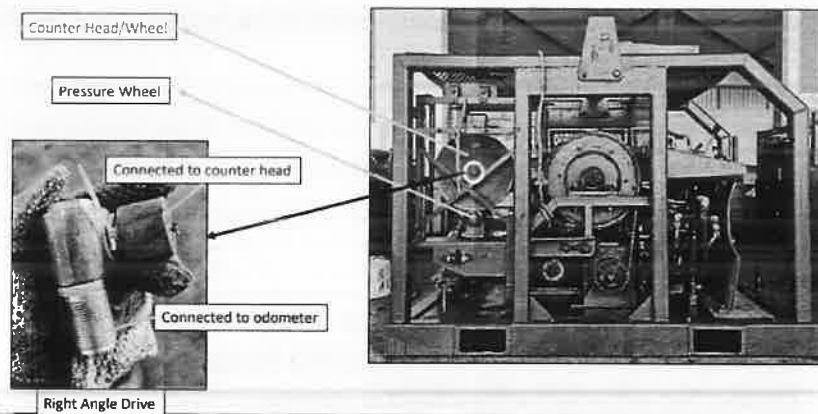



## **B.6. ODOMETER**

### **What is Odometer**

- also known as Depth Counter/ Depth Measuring device

### **What is the purpose of Odometer**

- To indicate the depth of slickline tool string hanging in a tubing string in feet or meters.

### **How to operate Odometer**

- Ensure the counter wheel is free to rotate.
- Check the rotation is being transmitted freely to odometer.
- Ensure the direction of rotation is correct.

### **What is maintenance required for Odometer**

- Check the cable has no kinks as it passes through the system.
- Check the odometer is fully engaged after zeroing.



**What is safety precaution required for Odometer**

- glass odometer should be clear
- make sure odometer number can read

**What is potential hazard during handling Odometer**

- pinch point
- glass odometer broke
- reading not accurate



**Draw & name each part of Odometer**

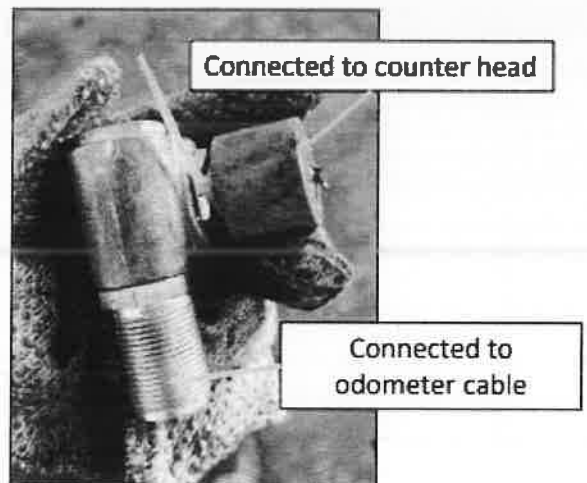
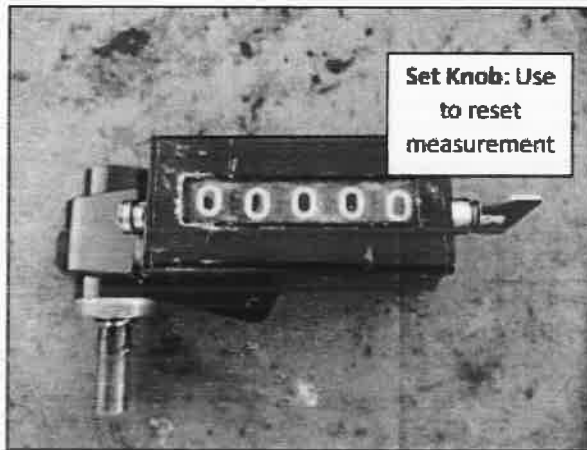

**Right Angle Drive**



### **B.7. WEIGHT INDICATOR (200 LBS AND 4000 LBS)**

#### **What is Weight Indicator**

- is systems are designed to provide accurate measurement of downhole tool weight during wireline operation

#### **What is the purpose of Weight Indicator**

- as a guide operation during running tool into the well

#### **How to operate Weight Indicator**

- connect weight indicator with load cell
- load all connect with hay pulley

#### **What is maintenance required for Weight Indicator**

- calibrate gauge
- remove bubble in the hose
- top up oil



What is safety precaution required for Weight Indicator

- secure proper gauge
- secure hose properly

What is potential hazard during handling Weight Indicator

- incorrect reading gauge
- hose burst

Draw & name each part of Weight Indicator

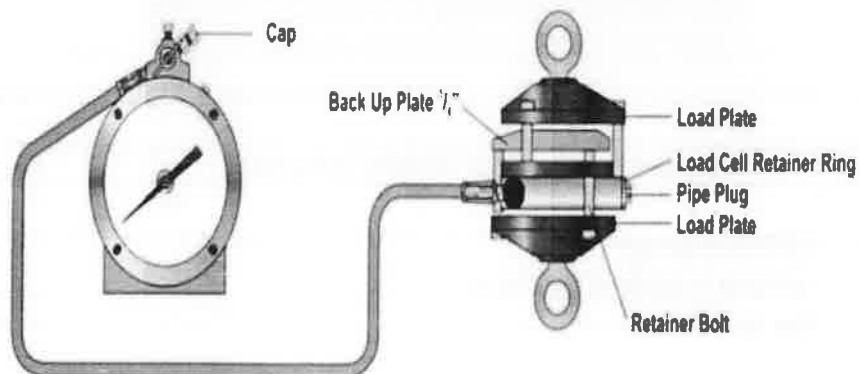
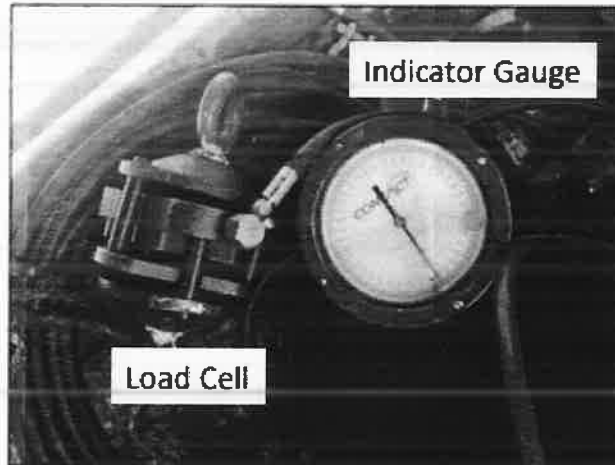



### **B.8. SPOOLING DEVICE**

**What is Spooling Device**

- is device to spool new wire from reel to drum or drum wire to another drum

**What is the purpose of Spooling Device**

- purpose to tension wire while spool new unit into the drum

**How to operate Spooling Device**

- must connect powerpack hose to spooling tool

**What is maintenance required for Spooling Device**

- check gear oil
- check hydraulic regulator

**What is safety precaution required for Spooling Device**



- barricade work site area
- full PPE

What is potential hazard during handling Spooling Device

- hose burst
- line of fire
- high tension wire

Draw & name each part of Spooling Device

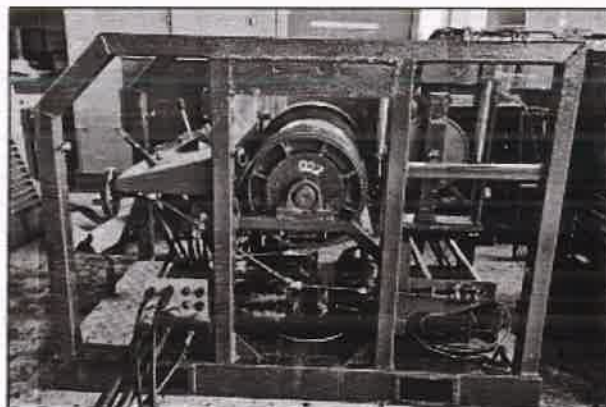

- Spooler Drum
- Drive sprocket
- Pre-set spooling
- Double brake in parallel



## **B.9. CONTROL PANEL**

What is Control Panel

- control panel are used to operate a number of valves

What is the purpose of Control Panel

- provide high pressure oil output from a low pressured air or gas input

How to operate Control Panel

- connect AC to supply air for control panel
- using regulator to pressure up line

What is maintenance required for Control Panel

- check gauge
- check hose
- check all tubing and connection
- check hydraulic oil

What is safety precaution required for Control Panel

- secure all hoses connection
- don't stand at line of fire
- check all connection and fitting



What is potential hazard during handling Control Panel

- hose burst
- tubing leaking
- high pressure

Draw & name each part of Control Panel

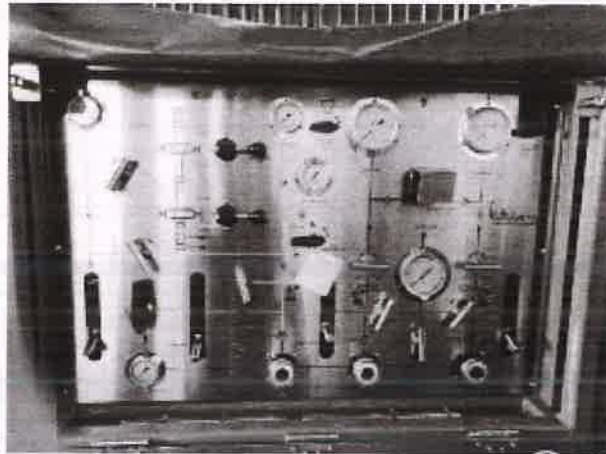

- Input supply pressure
- Panel supply
- Pump output
- LV  
~~SSV~~ pressure
- SSSV pressure
- HMV pressure.
- Regulator
- Bleed valve.



## **B.10. HUSKEL PUMP**

**What is Huskel Pump**

- generate fluid pressure

**What is the purpose of Huskel Pump**

- to pressure test PCE

**How to operate Huskel Pump**

- air supply control by air regulator

**What is maintenance required for Huskel Pump**

- service pump
- redress KIT

**What is safety precaution required for Huskel Pump**



- barricade area while function test

What is potential hazard during handling Huskel Pump

- air hose burst
- trap pressure
- line of fire

Draw & name each part of Huskel Pump

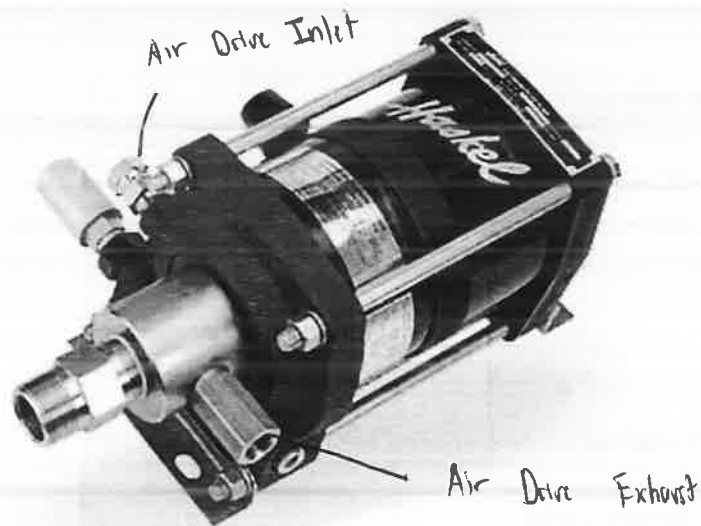



### **B.11. POWER PACK (ELECTRICAL & DIESEL)**

What is Power Pack

- power pack is a hydraulic supplier that contain engine to run hydraulic pump.

What is the purpose of Power Pack

- to supply hydraulic to run unit

How to operate Power Pack

- connect hydraulic hose to RSU then connect air hose to power pack to start

What is maintenance required for Power Pack

- change engine oil filter and check drain water on tank
- service when running hour

What is safety precaution required for Power Pack

- checking hose in good condition
- checking engine in good condition
- checking oil and water before start



**What is potential hazard during handling Power Pack**

- high pressure
- noise sound
- rotating part
- hot engine

**Draw & name each part of Power Pack**

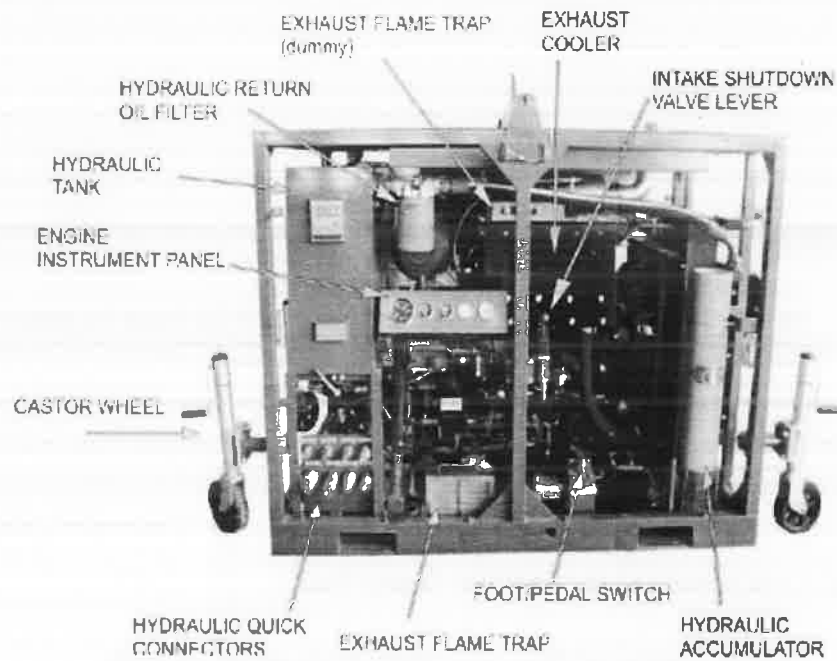



## **B.12. AIR COMPRESSOR**

**What is Air Compressor**

- engine equipment that used to supply air for run control panel

**What is the purpose of Air Compressor**

- supply air to equipment

**How to operate Air Compressor**

- using spring starter, hydraulic starter to power up
- air pressure using PRV

**What is maintenance required for Air Compressor**

- check hose whether in a good condition or not before use it
- change water, air cooler, filter, engine oil

**What is safety precaution required for Air Compressor**

- beware when rotating part
- check engine oil and make sure the oil level is according to its level



What is potential hazard during handling Air Compressor

- noise sound
- high pressure
- hose burst

Draw & name each part of Air Compressor

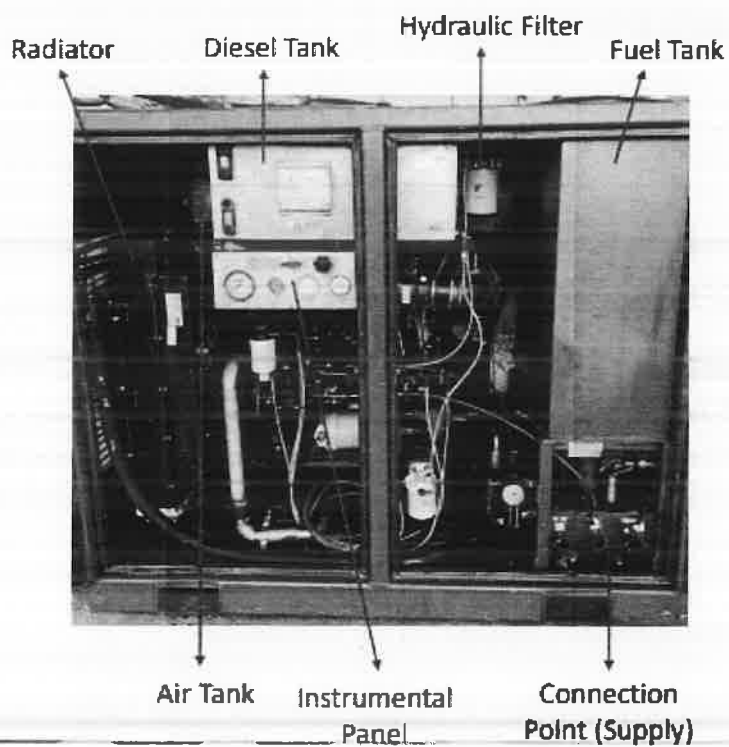



### B.13. DRUM

What is the purpose of Drum

the drum can be single or double to running wireline operations pull in out and brake.

Draw the right and wrong wire arrangement from drum to hay pulley

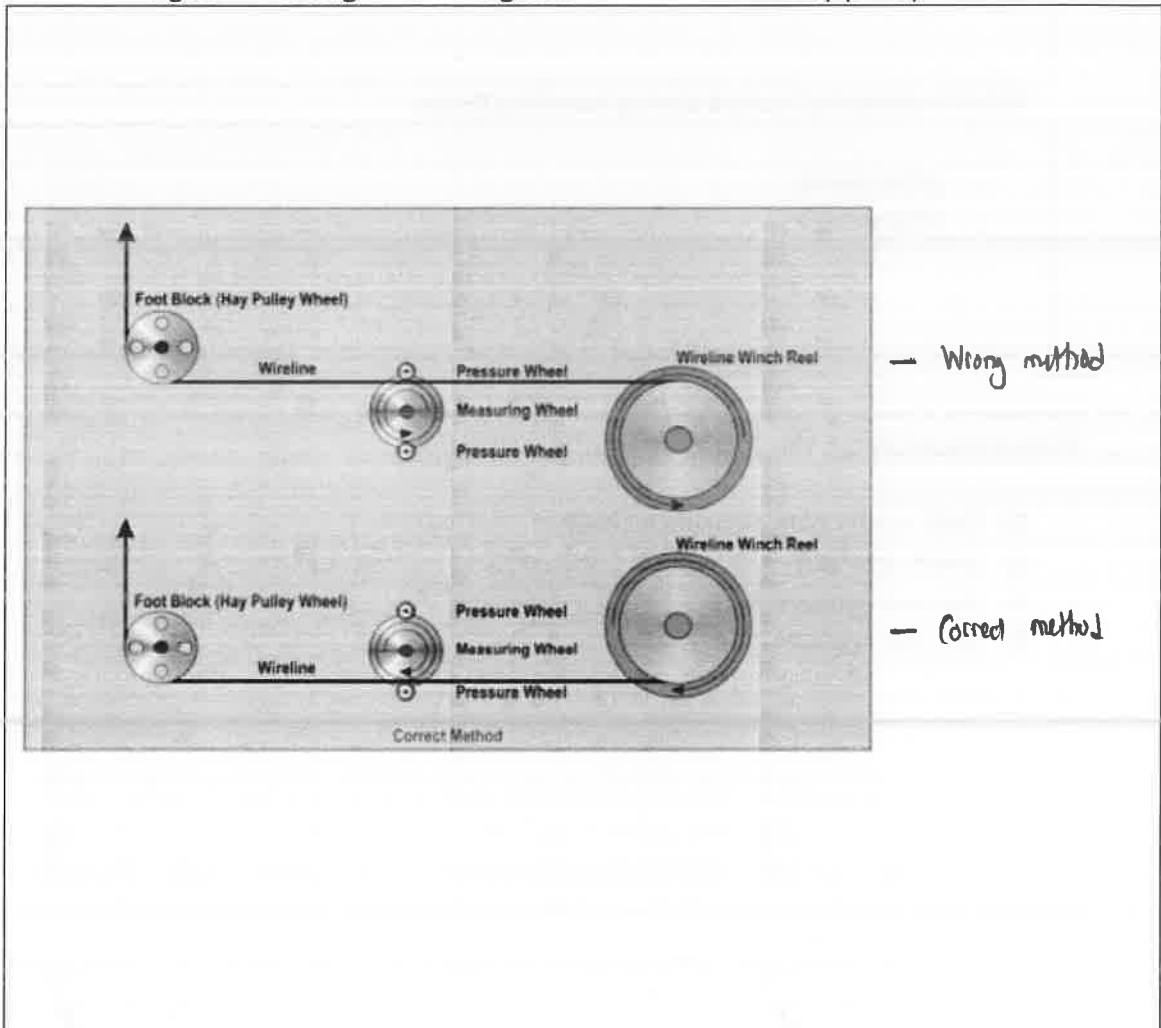

What is maintenance required for Drum



- greasing bearing

What is safety precaution required for Drum

- rotating casing

What is potential hazard during handling Drum

- pitch point
- sharp edge

Please draw/sketch the toolstring configuration for:

- 1) Drift run/tubing clearance check
- 2) Sinker bar run
- 3) Set and retrieve plug
- 4) Set and retrieve insert valve

