

TRAINEE ASSESSMENT

NAME : GEONELDIN CHAUHIN

DATE : 06/02/2025



CONTENT



01

SAFETY

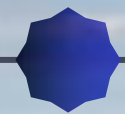

02

**INTRODUCTION
OF SLICKLINE**



03

**SURFACE
EQUIPMENT
(SE)**

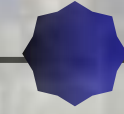

04

**PRESSURE
CONTROL
EQUIPMENT
(PCE)**



05

**DOWNHOLE
TOOLS (DHT)**

SAFETY

- Personal Protective Equipment(PPE)
- Permit
- Toolbox meeting



INTRODUCTION OF SLICKLINE

WHAT IS SLICKLINE?

- Slickline is a single strand wire which is used to run toolstring in the oil and gas well.
- Operation applied:
 - Routine job
 - Non – Routine job

Advantage:

- a. Low cost.
- b. Basic technology
- c. Small crew member.

Disadvantage:

- a. Low strength wire
- b. inability to rotate or circulate
- c. difficult to use in high angle wells

The diameter wire available:

- **0.108 (2500 breaking)**
- **0.125 (3300 breaking)**
- **0.140 (4050 breaking)**

Length wire available:

- **18,000ft**
- **20,000ft**
- **25,000ft**
- **30,000ft**





SURFACE EQUIPMENT (SE)

Power pack

Reel Skid Unit

Wireline Mask

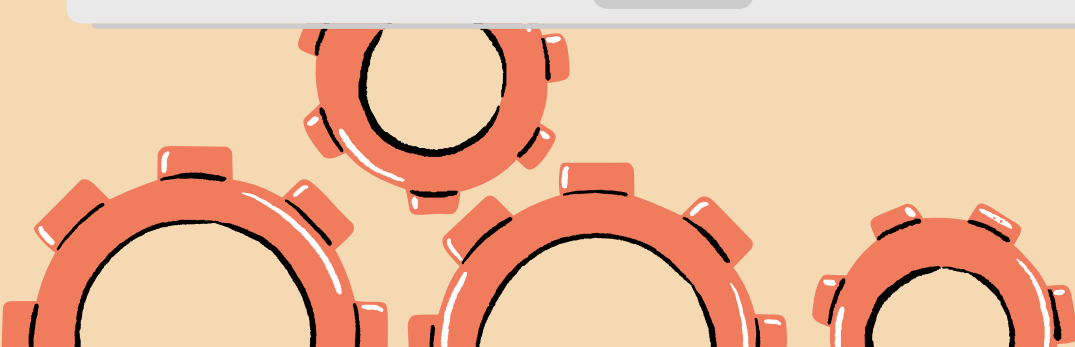
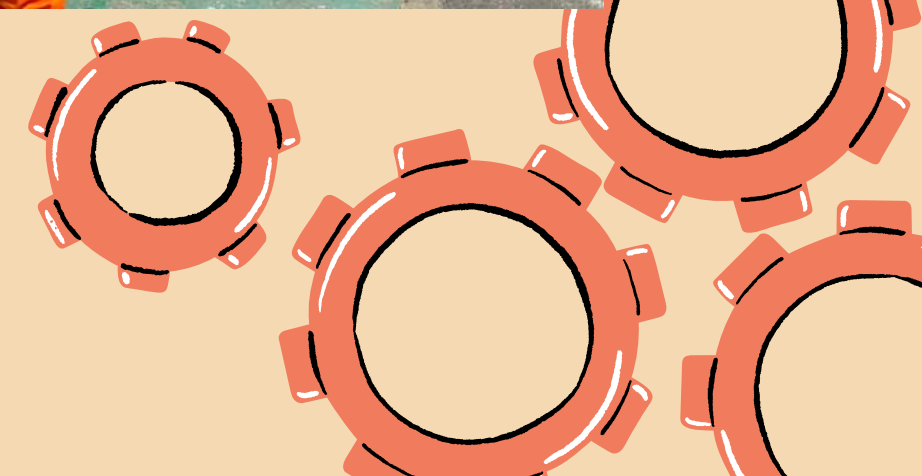
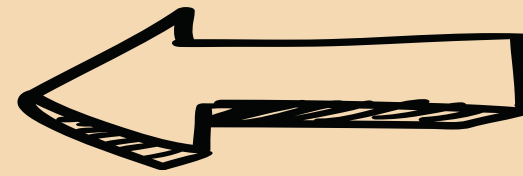

HAZARDOUS ARE:

ZONE 0 – explosive atmosphere is CONTINUOUSLY present

ZONE 1 – explosive atmosphere is OFTEN present

ZONE 2 – explosive atmosphere is ACCIDENTALLY present

POWER PACK

- Function – to supply hydraulic power for mast and RSU
- Diesel driven
- 80 horse power
- Zone 2 certified equipment
- 4 cylinder
- Starter type:
 - Hydraulic starter
 - Spring starter

Type for power pack:

- Close Loop hydraulic system:
 - NOV FLYLINE
- Open loop hydraulic system
 - SOP
 - TIP
 - NOV LIGHTLINE



NOV LIGHTLINE POWER PACK



SOP POWER PACK



NOV FLYLINE POWER PACK

Safety Shutdown System	Set At
Overspeed Shutdown	2200 RPM
Low engine oil pressure	15 PSI
High coolant temperature	99 Deg Celsius
High exhaust temperature	200 Deg Celsius

How to start power pack (FLYLINE)

1) Sentinel valve



2) Winding nut



3) Air inlet valve



4) Spring tip lever



How to start power pack (SOP)

1) Sentinel valve



2) Hand pump



3) Intake shutdown valve



4) Pedal start switch



How to start power pack (LIGHTLINE)

1) Hand pump



2) pump oil pressure



3) Intake shutdown valve



4) Pedal start switch



hydraulic Quick Connector Type:

- Holmbury
- Snaptite

REEL SKID UNIT (RSU)

- **Function** - To turn the wire drum to lower and rise tool strings in the wells that require wireline servicing.
- Known as winch or wireline unit
- Available with single or double drum
- Max working pressure 2200 psi- 2500 psi



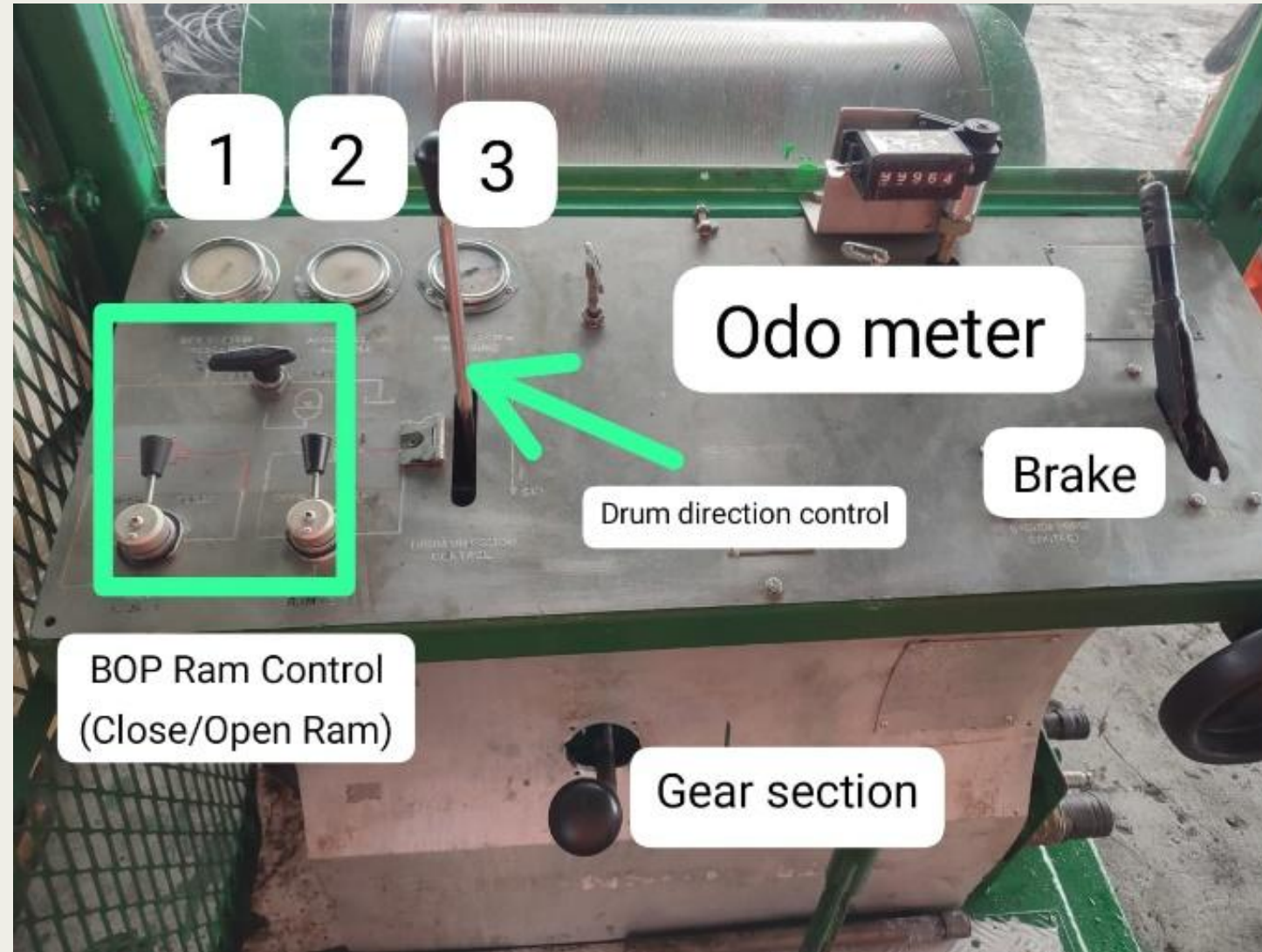
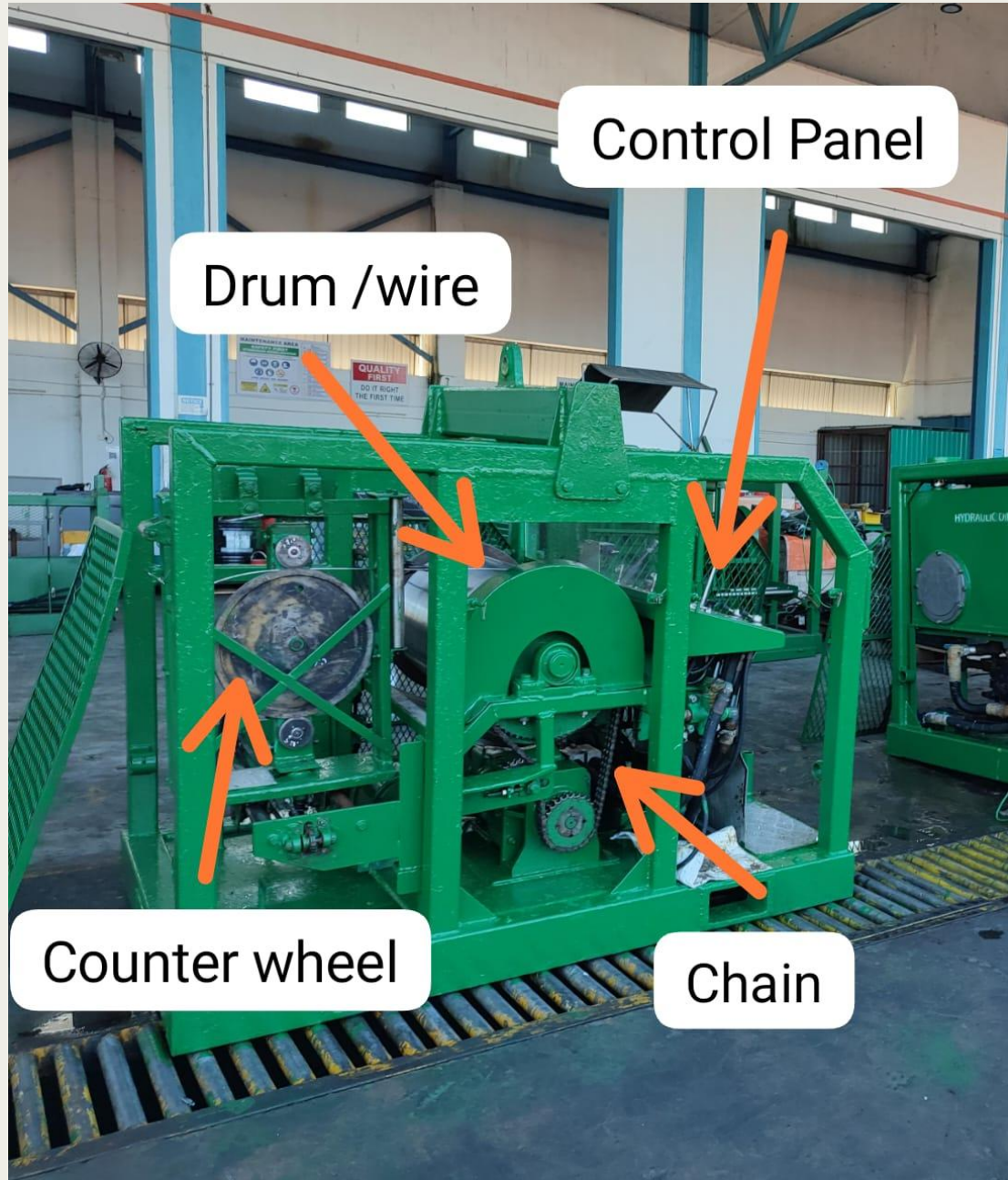

- 1) BOP System Pressure
- 2) Accumulator Pressure
- 3) Winch System Pressure



HAY PULLEY

- To bring wireline drum from stuffing box and into horizontal to the wireline winch drum.
- The wire should form 90 degree angle at the pulley.
- This 90 degree angle is important to provide an accurate reading of line tension on the weight indicator.
- Hooked directly on to the eye of weight indicator/load cell.



Wire Tester

- Function -To determined condition of the wire
- Result will recorder at chart recorder in lbs
- Suitable for ZERON 100hs



Diameter (Inch)	Minimum Breaking Load (LBS)	Minimum Torsion	Safe Working Pressure (60%)
0.108"	2500	3	1500
0.125"	3300	2	1980
0.140"	4050	2	2430

Zeron 100
HS
Stainless
Steel Wire

Weight Indicator

- Function – to determine the total weight of tools hung in the tubing string.
- Available :
 - 2000 LBS
 - 4000 LBS
 - 5000 LBS



odometer

- Known as counter depth
- Use for measuring deapth
- Device should be manually set at sero



Y Pump & Fluid

- Y pump use for pumped W15 fluid ib hose
- W15 fluidfor hose





WIRELIN MAST

- To lift or hanging lubricator during operation (rig up)
- Available at 30FT , 40 FT , 70FT
- 70ft zone 1

Neu
Dimension
Your Integrated Solutions

PRESSURE CONTROL EQUIPMENT

- QUICK UNION
- STUFFING BOX
- LUBRICATOR
- QUICK TEST SUB
- BLOWOUT PREVENTER
- BALL VALVE
- PUMP IN TEE
- CROSSOVER
- CONTROL PANEL
- PRESSURE TEST UNIT
- LOW TORQUE VALVE
- ACCESSORIES

QUICK UNION

- Connection that use for assembly slickline of PCE
- Otis type connection – 45 degree
- Bowen type connection – 90 degree
- Difference between Otis and bowen are external holes, internal angle and pin diameter
- Typical for 3" ID :
 - 5" thread size
 - 4 thread per inch
- Working pressure – 5000 psi

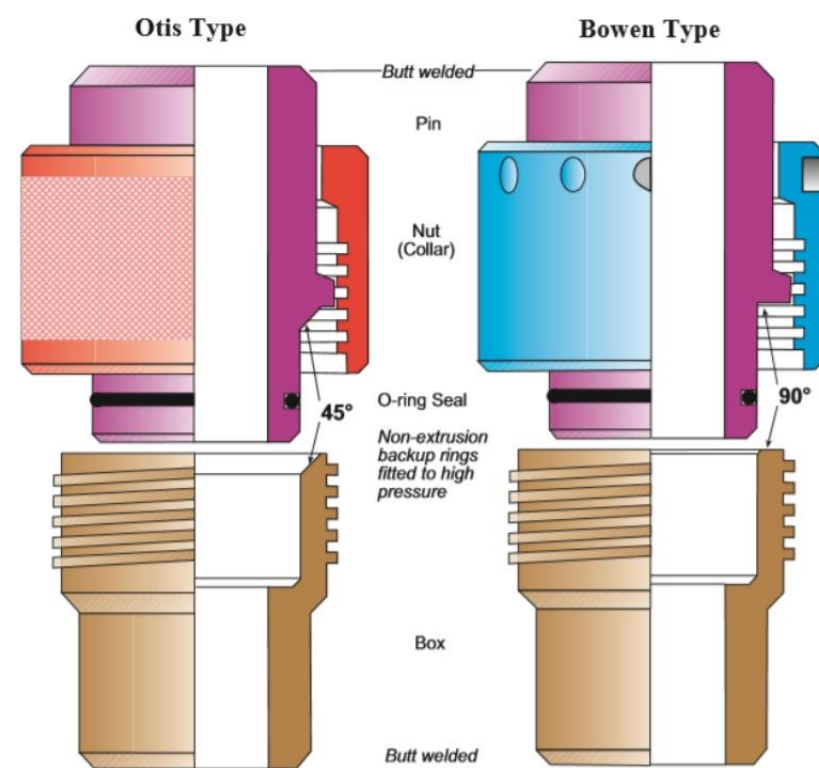

STUFFING BOX

Neu
Dimension
Your Integrated Solutions Partner



- As primary barrier
- Contains well pressure while the slickline is either moving or stationary
- Can be operated by hand pump
- Sheave diameter 16" , 18" , 20"
- Guides the wire from the bottom hay pulley into the top of the lubricator rig up
- **Brass** internal components prevent slickline damage
- Working pressure – 5000 psi

STUFFING BOX

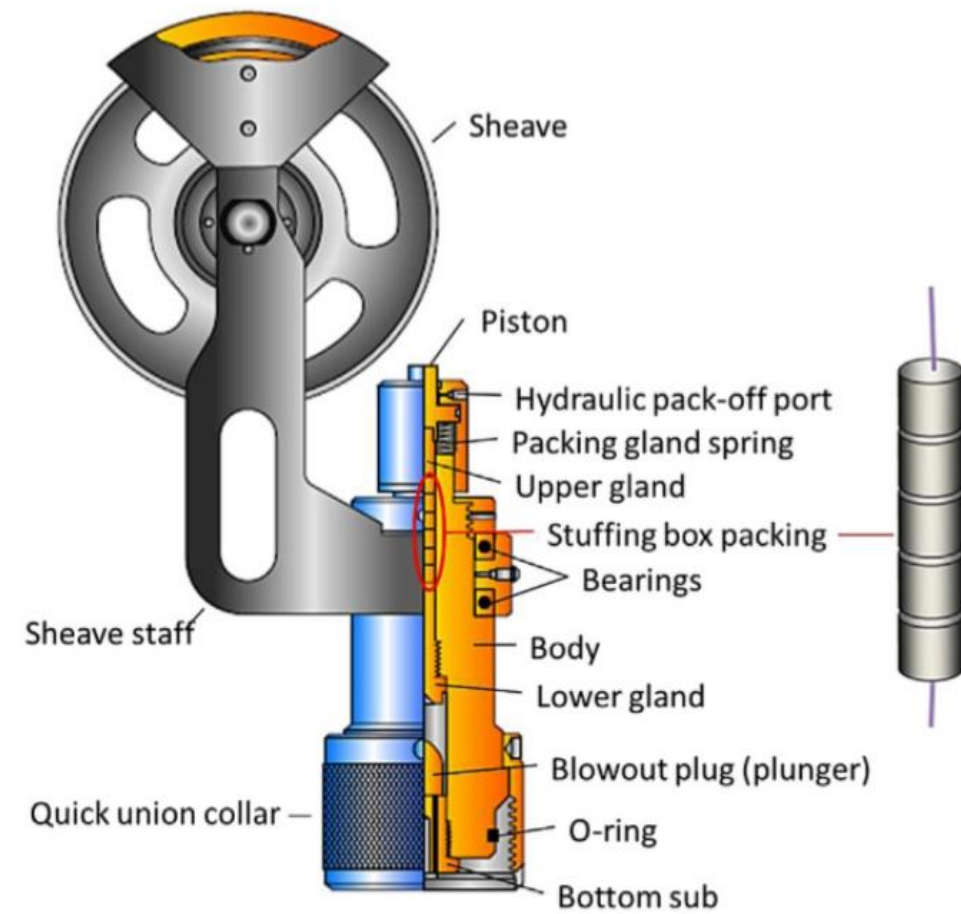

Neu 
Dimension
Your Integrated Solutions Partner



LUBRICATOR

- To provide space for the tool to be contained in under pressure when opening and closing the wellhead
- Have non ported and ported
- Available in 2ft , 4ft , 8ft
- The length of lubricator depends on the tool string length
- The longer the downhole tools the more lubricator needed

Working Pressure (WP) psi *	Test Pressure (TP) psi
3,000	4,500
5,000	7,500
10,000	15,000
15,000	22,500

QUICK TEST SUB



- The quick test sub makes it easy to make change tool string during multiple run
- Placed at “break point” below lubricator and above bop
- Can be pressure test using hand pump 4000psi

Neu 
Dimension
Your Integrated Solutions Partner

BLOWOUT PREVENTER

- To seal the line or ensure pressure to be isolated without cutting the wire
- Secondary barrier
- Operated by hydraulic or manual
- Hold pressure from below
- Mechanically and hydraulically to close the rams
- Each arm has fittings for hydraulic
- Maximum working pressure 5k psi
- Dual ram and single ram
- Sizes: 3", 4" and 7"



Neu
Dimension
Your Integrated Solutions Partner

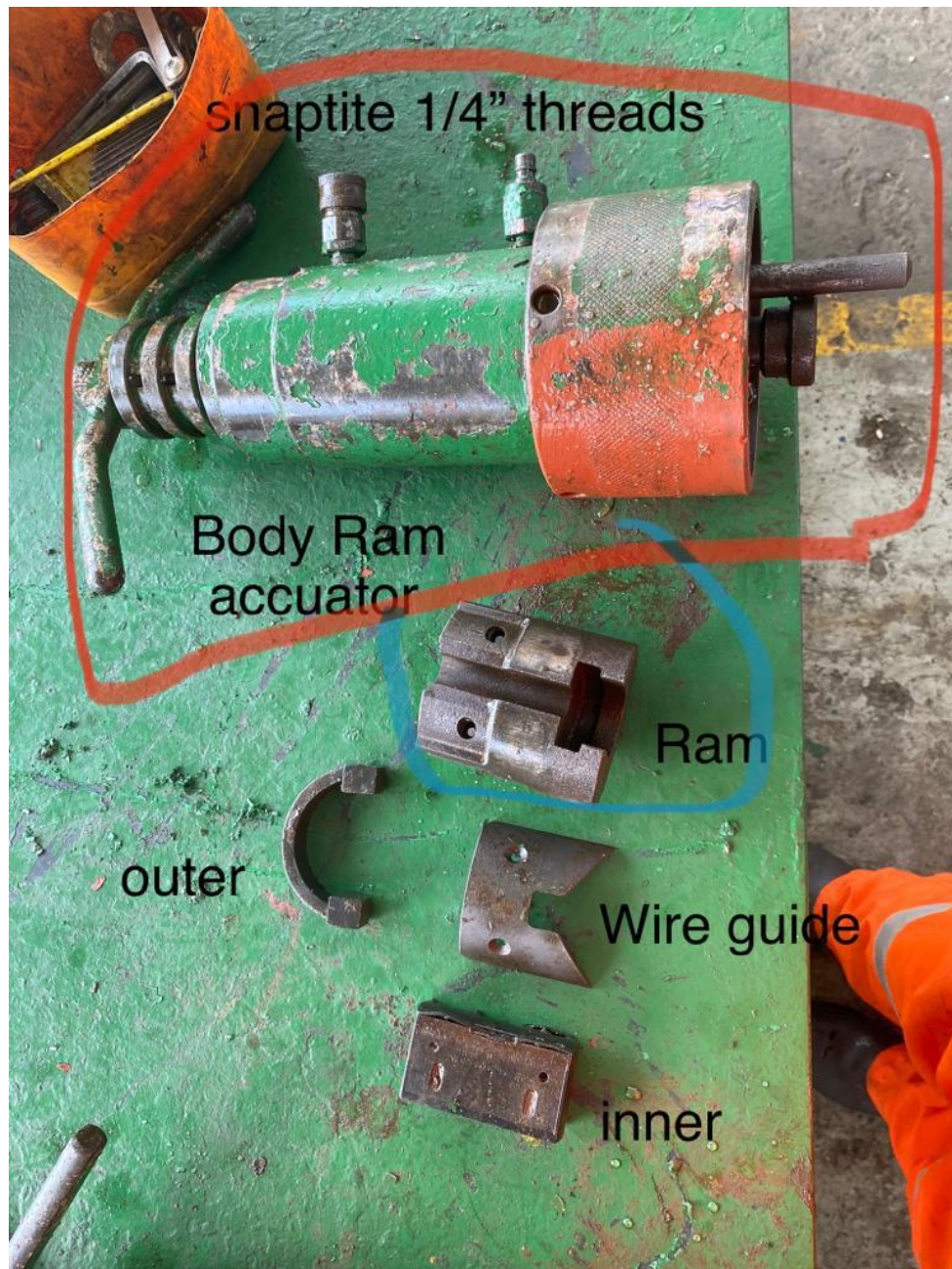

Neu 
Dimension
 Your Integrated Solutions Partner

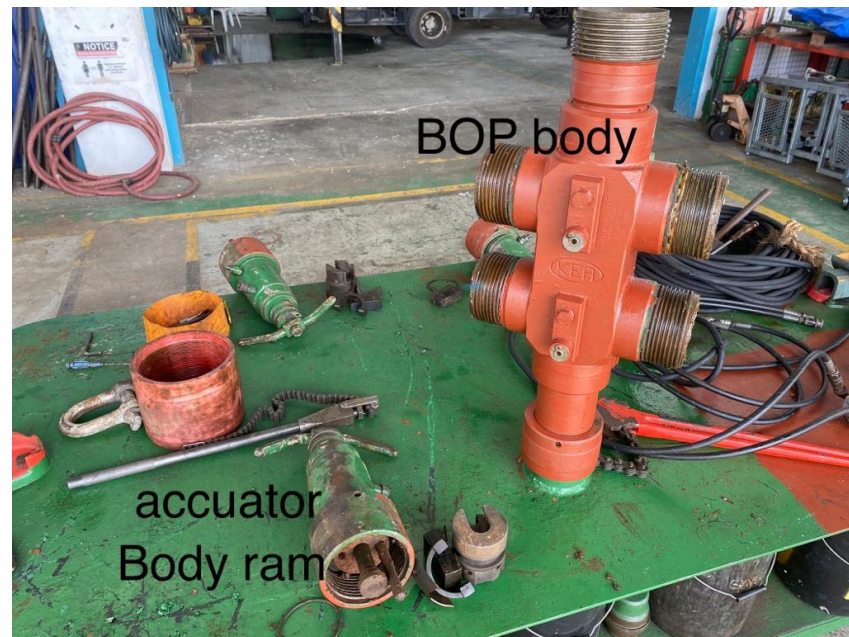
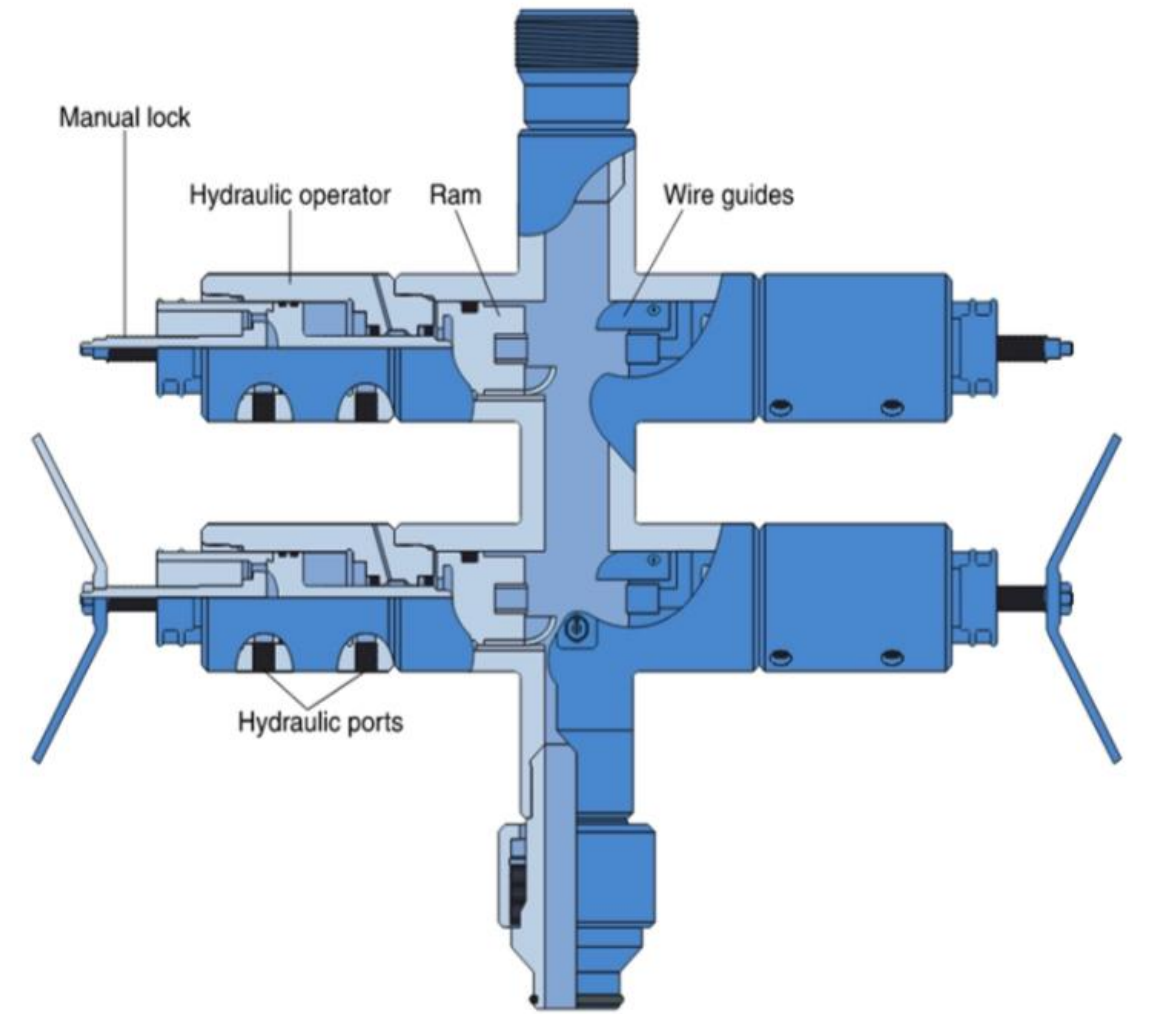
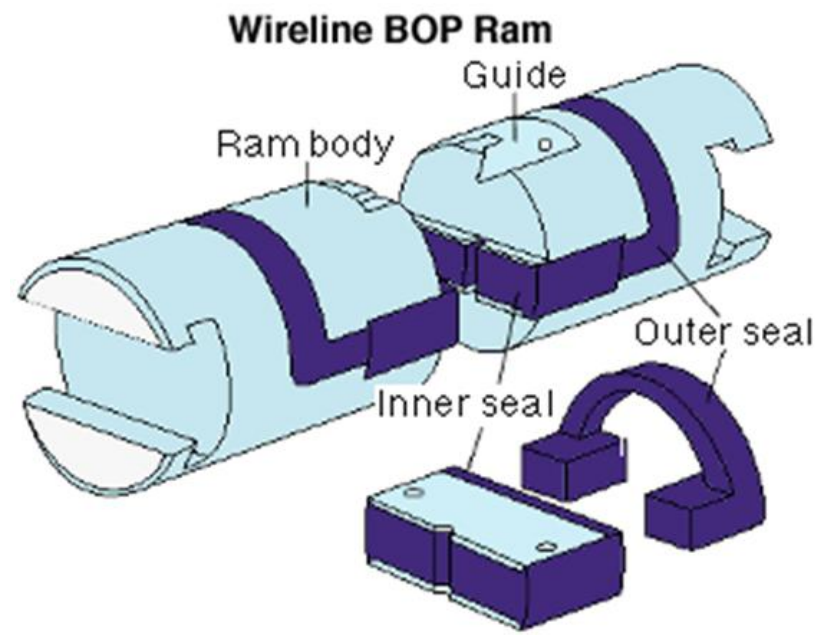

BLOWOUT PREVENTER

BALL VALVE

- Operated hydraulically and manual
- Ball valves are capable to cut wire
- Hold pressure from above and below
- Can use for pressure test



Neu 
Dimension
Your Integrated Solutions Partner

PUMP IN TEE

- Use for chemical injection point
- It is normally positioned below the BOP and above wellhead

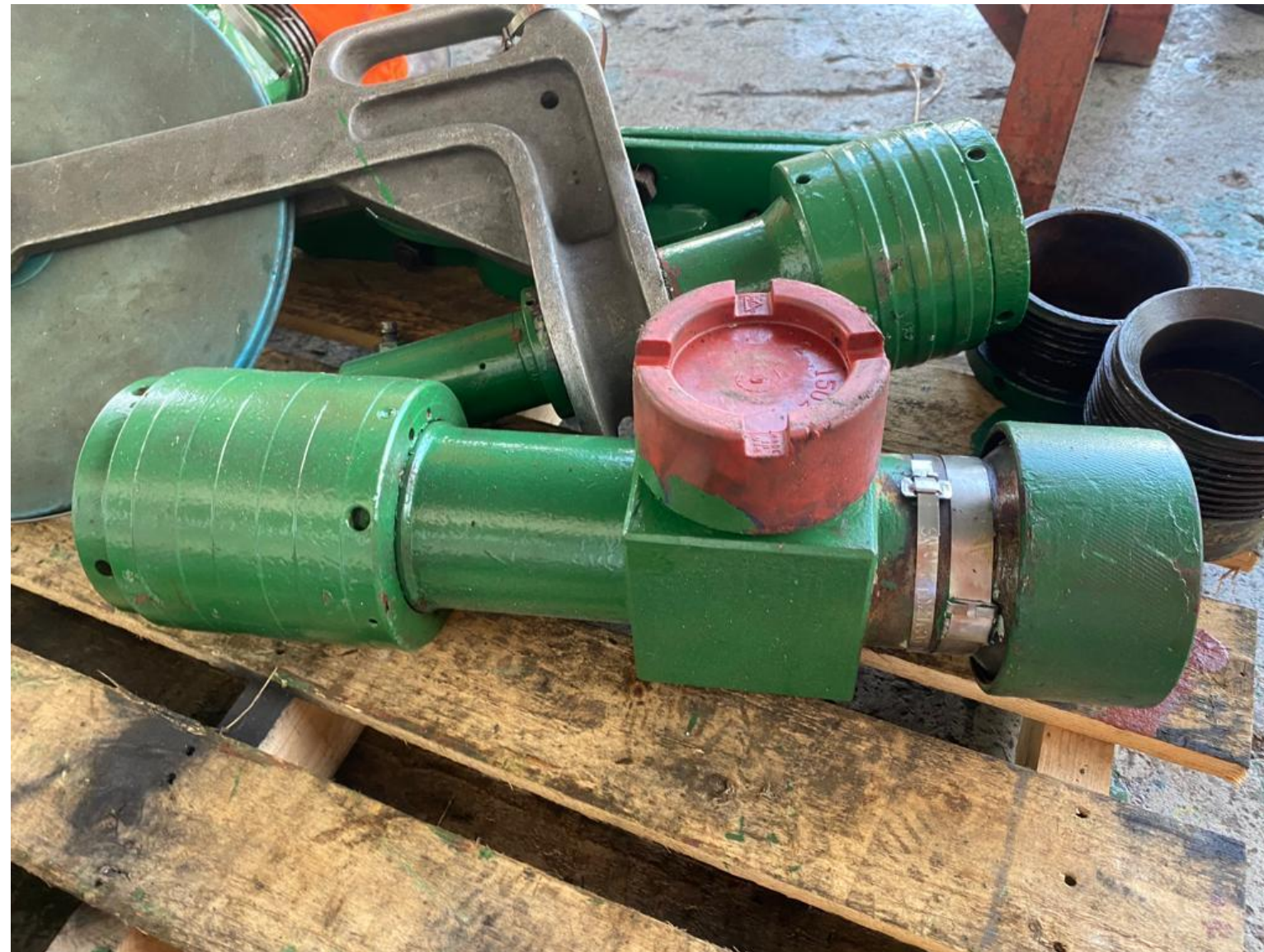

CROSSOVER

- To provide transition between different size threads size and otherwise incompatible unions made by same or different manufactures



CONTROL PANEL

- **CONTROL PANEL(CP)** – to operate BOP ram
- **SINGLE WELL CONTROL PANEL(SWCP)**- to operate MV and SCSSV
- **WELL CONTROL PANEL(WCP)**- an integrated CP can operate BOP, Stuffing box, MV and SCSSV
- Air supply : 100 to 110 psi



Neu // // // //
Dimension
Your Integrated Solutions Partner

Neu

Dimension

Your Integrated Solutions Partner

PRESSURE TEST UNIT (PTU)

- To pump fluid or pressure test the PCE component
- Fast filling and high pressure pump for testing up to maximum 15,000 psi
- The test result is recorded on chart recorder



CP ,SWCP &WCP



Control panel



Single Well Control Panel



Well Control Panel

LOW TORQUE VALVE

To control the fluid flow by rotating the handle or other similar operation



Neu 
Dimension
Your Integrated Solutions Partner

ACCESSORIES

Lifting test cap



Stand



Dolley



Lifting clamp

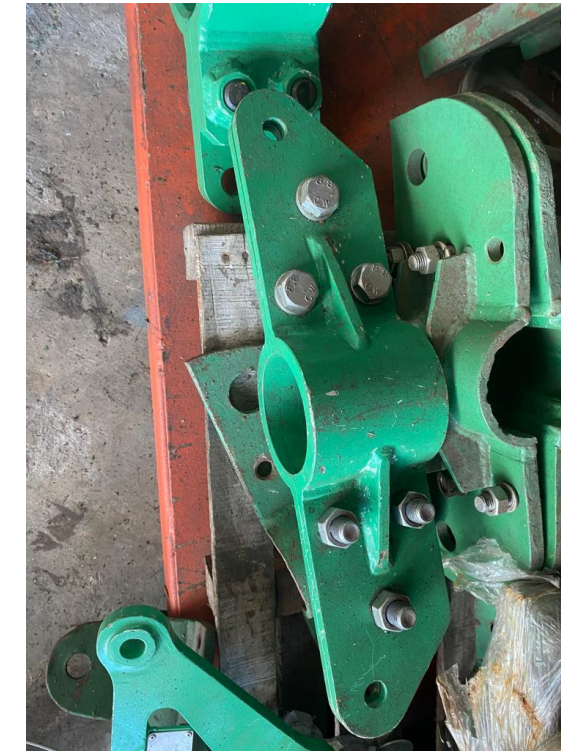

PCE CONFIGURATION

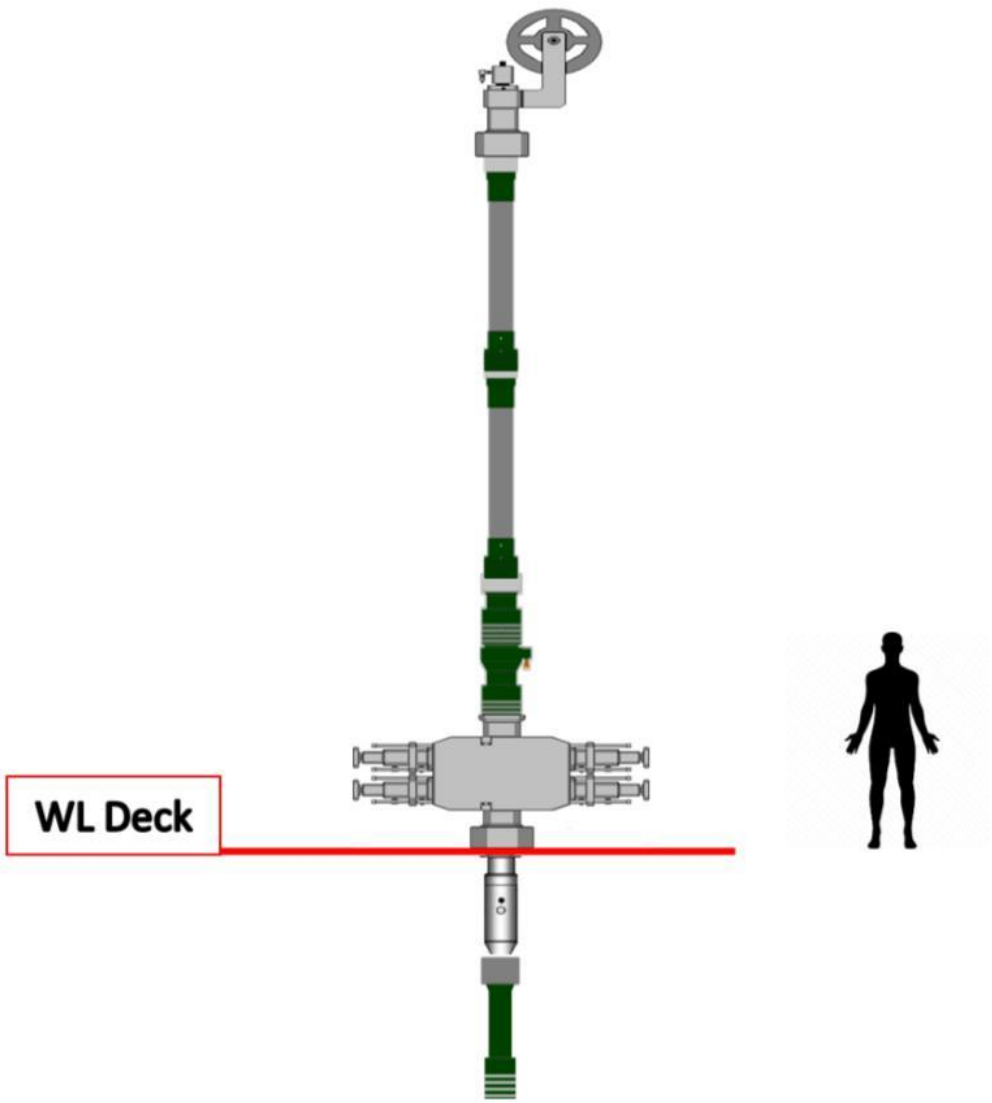
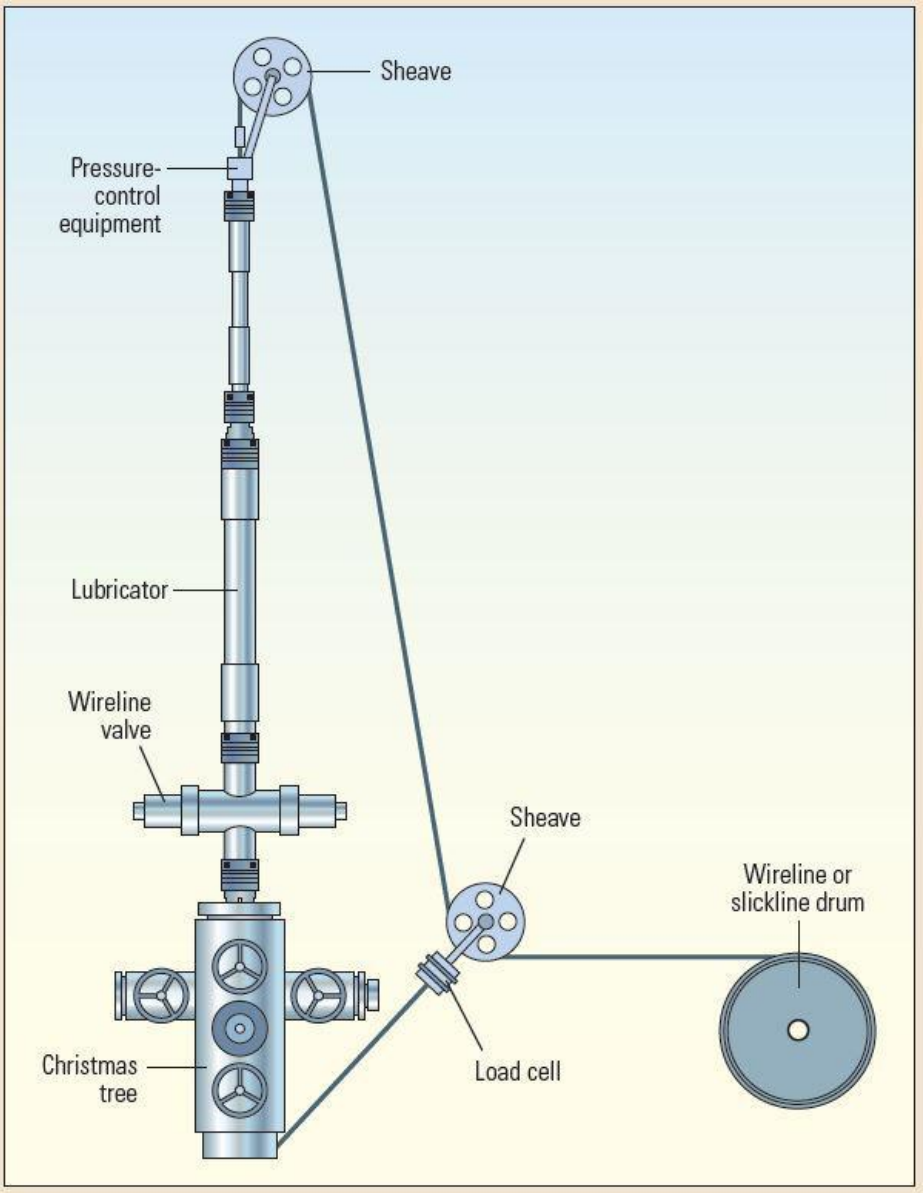

DOWNHOLE TOOLS



ROPE SOCKET

DOWNHOLE TOOLS CONNECTION

SWIVEL JOINT

STEM/WEIGHT BAR

LINK JAR

KNUCKLE JOINT

ROPE SOCKET

- Used as a method of connection the slickline wire to the tool string ,from wire sizes from 0.108", 0.125" and 0.140"
- 3 type of rope socket (PEAR DROP TYPE, SPRING , DISC TYPE and BRAIDED CLAMP TYPE)
- For tubing 3.1/2 RS size 1.7/8 , tubing 2.7/8 RS size 1.1/2 , tubing 2.3/8 RS size 1.1/4

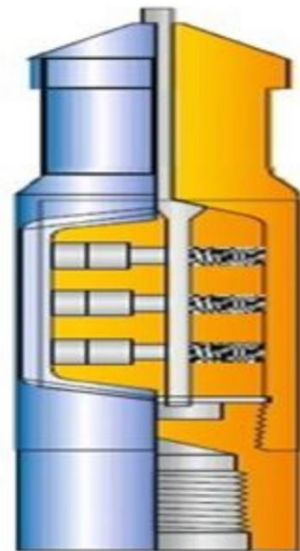

Disc type



Clamp type



Pear drop type

DOWNHOLE TOOLS CONNECTION

CONNECTION SIZE

Sucker rod thread(TPI)

- 15/16-10
- 1 1/16
- 1 9/16

Quick lock system

- 1 ½
- 1 7/8
- 2 ½

Shear pin size

- 1/8
- 3/16
- ¼
- 5/16
- 3/8



DOWNHOLE TOOL CONNECTION

- Sucker rod
- Quick lock system (QLS)
- Quick release joint (QRJ)
- Trinity



Sucker rod



QLS

Neu

Dimension

Your Integrated Solutions Part



SWIVEL JOINT

- Swivel joint is a wireline accessory used to minimise the effect of the wire twist caused by subsurface devices being run
- The swivel joint has a double fish neck
- Sideways movement of swivel varies from 1.5 to 5 degree



STEM

- It is known as weight bar/sinker bar
 - To provide the weight of the toolstring
 - Also giving a weight impact while jarring operation
 - Available in 2ft , 3ft , 5ft
 - Other type of stem:
 1. Roller stem
 2. Lead filled stem
 3. Tungsten stem
- *The heaviest is tungsten stem*

Table

- Weight of normal stem calculation
- OD 2(inch) x 8/3= weight LB/FT

OD (inch)	Weight lb/ft	Fishing Neck
1	2.5lbs	0.875"
1.1/4	4.2lbs	1.187"
1.1/2	6.0lbs	1.375"
1.7/8	9.4lbs	1.750"
2.1/8	12lbs	1.750"
2.1/2	16.7lbs	2.313"

LINK JAR

- It is also known as spang jar / mechanical jar
- Design to act like a sliding hammer by utilising the weight of the stem bars to convey a powerful jarring action
- Available with 20" and 30" stroke
- Other type of jar are hydraulic jar , tubular jar , spring jar , and upstroke jar



Link jar



hydraulic jar

KNUCKLE JOINT

- Knuckle joints are used to add flexibility within the tool string and are particularly effective within deviated well bores
- 15 degree angle movement



FISHING NECK DIMENSION

External Fishing Neck (inch)

Nominal tool size	Fish Neck (SRT)
1"	1.000"
1 1/4"	1.187"
1 1/2"	1.375"
1 7/8"	1.750"
2 1/8"	1.750"
2 1/2"	2.313"