

# DIMENSION BID



---

## ANGSI A-12S WELL DIAGNOSIS WITH CAMERA RUN & ACID STIMULATION

---

Revision: 2  
Prepared for: Nik M Qusyairi B. M Zulkifli  
Date Prepared: 16<sup>th</sup> March 2023  
Well: A-12S  
Field: ANCSI  
Operation Region: PMA  
Prepared by: Muhd Ameerul Zaeem  
Phone: +601129033294  
Email: ameerul@neudimension.com

<b>DIMENSION BID</b>	DIMENSION BID COILED TUBING SERVICES		
	ANGSI A-12S	WELL DIAGNOSIS WITH CAMERA RUN	

**DESIGN VERIFICATION**

**PREPARED BY DB**  
CTS Field Engineer



\_\_\_\_\_

Muhammad Ameerul Zaeem

16/3/2023  
Date

**REVIEWED BY DB**  
CTS Technical Advisor



\_\_\_\_\_

Kung Yee Han

16/3/2023  
Date

**APPROVED BY DB**  
CTS Operation Manager



\_\_\_\_\_

Aliff Amirul Adenan

16/3/2023  
Date

**APPROVED BY PCSB**  
Angsi  
Well Intervention Engineer

\_\_\_\_\_

Nik M Qusyairi B. M Zulkifli

Date

**APPROVED BY PCSB**  
Technical Professional  
Well Intervention, PMA

\_\_\_\_\_

M Izwan B A Jalil

Date

**APPROVED BY PCSB**  
Head of Cluster 1  
Well Intervention, PMA

\_\_\_\_\_

Ahmad Hafizi B Ahmad Zaini

Date

**Remark: Do not execute the procedures in this document if it is not fully approved and signed by all parties.**

Prepared By: M. Ameerul Zaeem	Reviewed By: Kung Yee Han	Date: 16/3/2023	Rev. Rev.2	Controlled Document DB-CT-MAZ-23001	Pg. 2
----------------------------------	------------------------------	--------------------	---------------	--	----------

<b>DIMENSION BID</b>	<b>DIMENSION BID COILED TUBING SERVICES</b>		
	ANGSI A-12S	WELL DIAGNOSIS WITH CAMERA RUN	

## DISTRIBUTION LIST

<b>No</b>	<b>Personnel</b>	<b>Company</b>	<b>Name</b>	<b>Email</b>
1	Well Intervention Engineer	PCSB	Nik M Qusyairi B. M Zulkifli	qusyairi.zulkifli@petronas.com
2	Well Service Supervisor (WSS)	PCSB	TBA	TBA
3	Offshore Installation Manager (OIM)	PCSB	TBA	TBA
4	Production Technologist	PCSB	TBA	TBA
5	Cluster Head	PCSB	Ahmad Hafizi B. Ahmad Zaini	hafizi.zaini@petronas.com
6	Head of well Intervention	PCSB	Eddy B Samaile	eddysamaile@petronas.com
7	Material Coordinator (Logistics)	DB – Kemaman	Marzokey	marzokey@neudimension.com
8	Service Supervisor	DB – Kemaman	TBA	TBA
9	Field Engineer Coiled Tubing Services	DB – Kemaman	Muhammad Ameerul Zaeem	ameerul@neudimension.com
10	Operation Engineer Coiled Tubing Services	DB – Kemaman	Mohammad Faizal Ali	faizal.ali@neudimension.com
11	Technical Advisor Coiled Tubing Services	DB – Kemaman	Kung Yee Han	yeehan.kung@neudimension.com
12	Operation Manager Coiled Tubing Services	DB – Kemaman	Aliff Amirul Adenan	aliff.adenan@neudimension.com
13	Field Service Manager Coiled Tubing Services	DB – Kemaman	Mohd Khairul Ridhwan	khairul.ridhwan@neudimension.com
14	HSE Supervisor	DB – Kemaman	Ahmad	ahmad@neudimension.com

Prepared By: M. Ameerul Zaeem	Reviewed By: Kung Yee Han	Date: 16/3/2023	Rev. Rev.2	Controlled Document DB-CT-MAZ-23001	Pg. 3
----------------------------------	------------------------------	--------------------	---------------	--	----------

<b>DIMENSION BID</b>	DIMENSION BID COILED TUBING SERVICES		
	ANGSI A-12S	WELL DIAGNOSIS WITH CAMERA RUN	

## PERSONNEL CONTACT

Any means of following doubt / unusual parameters / Emergency, please contact Dimension Bid personnel in onshore immediately.

No	Name	Position	Company	Location	Contact No
1	Aliff Amirul Adenan	Operation Manager	DB	Kemaman	011 – 1225 7044
2	Mohd Khairul Ridhwan	Field Services Manager	DB	Kemaman	014 – 515 4452
3	Kung Yee Han	Technical Advisor	DB	Kemaman	011 – 612 05611
4	Mohammad Faizal Ali	Operation Engineer	DB	Kemaman	013 – 736 1046

## REVISION HISTORY

Rev. No	Section	Date	Revised By
0	All	25/4/2022	Muhd Ameerul Zaeem
1	To include latest pipe tracking management, decision tree and plan operation timeline.	17/1/2023	Muhd Ameerul Zaeem
2	To include Contingency Impact Hammer & Acid Stimulation on I-68 procedure	16/3/2023	Muhd Ameerul Zaeem

## ACRONYM

Acronym	Abbreviation
BHA	Bottom Hole Assembly
RIH	Run In Hole
POOH	Pull Out Of Hole
HUD	Hang Up Depth
TCC	Tubing Clearance Check
ZSO	Zone Shut Off
SCO	Sand Clean Out
TIT	Tubing Integrity Test
BOP	Blow Out Preventer

CT	Coil Tubing
ID	Internal Diameter
MDTHF	Measure Depth Tubing Head Flange
SSD	Sliding Side Door
P&A	Plug and Abandonment
MASTP	Maximum Allowable Surface Treating Pressure
STP	Surface Treating Pressure

Prepared By: M. Ameerul Zaeem	Reviewed By: Kung Yee Han	Date: 16/3/2023	Rev. Rev.2	Controlled Document DB-CT-MAZ-23001	Pg. 4
----------------------------------	------------------------------	--------------------	---------------	--	----------

<b>DIMENSION BID</b>	DIMENSION BID COILED TUBING SERVICES		
	ANGSI A-12S	WELL DIAGNOSIS WITH CAMERA RUN	

## TABLE OF CONTENT

.....	1
<b>DESIGN VERIFICATION</b> .....	2
<b>DISTRIBUTION LIST</b> .....	3
<b>REVISION HISTORY</b> .....	4
<b>ACRONYM</b> .....	4
<b>TABLE OF CONTENT</b> .....	5
<b>OBJECTIVES</b> .....	7
<b>BACKGROUND</b> .....	7
<b>WELL DATA</b> .....	7
<b>OPERATION SUMMARY</b> .....	8
<b>WELL DIAGRAM</b> .....	9
<b>WELL 3D PLOT</b> .....	10
<b>TREATMENT VOLUME</b> .....	11
<b>COILED TUBING STRING INFORMATION</b> .....	12
<b>CT STRING FATIGUE</b> .....	12
<b>CT STRING #40146 LATEST PIPE MANAGEMENT</b> .....	13
<b>PROCESS FLOW DIAGRAM</b> .....	14
<b>SAFETY OPERATIONAL PROCEDURES</b> .....	15
<b>HEALTH, SAFETY &amp; ENVIRONMENT</b> .....	16
<b>EQUIPMENT RIG UP PROCEDURE</b> .....	17
<b>EQUIPMENT PRESSURE TESTING PROCEDURE</b> .....	19
<b>CT STRING MANAGEMENT DURING OPERATION</b> .....	20
<b>OPERATIONAL PROCEDURE</b> .....	21
<b>SLICKLINE OPERATION</b> .....	21
<b>COILED TUBING OPERATION – RUN#1 DRIFT RUN UNTIL TOP OF PXN PLUG AT 3,049 M MDDF / 10,000 FT MDDF</b> .....	22
<b>COILED TUBING OPERATION – RUN#2 RUN EV CAMERA UNTIL TOP OF PXN PLUG AT 3,049 M MDDF / 10,000 FT MDDF</b> .....	28
<b>COILED TUBING OPERATION – RUN#3 ACID STIMULATION ON I-68</b> .....	32
<b>CT CONTINGENCY #1 – 2.25” IMPACT HAMMER C/W 2.60” PORTED BLINDBOX</b> .....	40
<b>APPENDIX I – BOTTOM HOLE ASSEMBLY SCHEMATIC</b> .....	42
<b>APPENDIX III – ORPHEUS SIMULATIONS</b> .....	47
<b>APPENDIX IV – EMERGENCY PROCEDURE</b> .....	51
<b>EMERGENCY BOP OPERATIONS</b> .....	51
<b>LEAK IN COILED TUBING AT SURFACE</b> .....	52

Prepared By: M. Ameerul Zaeem	Reviewed By: Kung Yee Han	Date: 16/3/2023	Rev. Rev.2	Controlled Document DB-CT-MAZ-23001	Pg. 5
----------------------------------	------------------------------	--------------------	---------------	--	----------

<b>DIMENSION BID</b>	DIMENSION BID COILED TUBING SERVICES		
	ANGSI A-12S	WELL DIAGNOSIS WITH CAMERA RUN	

<b>LEAK IN COILED TUBING BELOW SURFACE.....</b>	52
<b>LEAK IN SURFACE PRESSURE CONTROL EQUIPMENT .....</b>	53
<b>COILED TUBING RUNS AWAY INTO WELL .....</b>	54
<b>COILED TUBING IS PULLED OUT OF STUFFING BOX .....</b>	55
<b>COILED TUBING COLLAPSED AT SURFACE.....</b>	55
<b>COILED TUBING BREAKS AT SURFACE .....</b>	56
<b>BUCKLED TUBING.....</b>	56
<b>COILED TUBING STUCK IN HOLE PROCEDURES.....</b>	58
<b>STUCK CT COIL RECOVERY PROCESS.....</b>	60
<b>APPENDIX V – DECISION TREE.....</b>	61
<b>APPENDIX VI – PROJECT OPERATION TIMELINE .....</b>	65

<b>DIMENSION BID</b>	DIMENSION BID COILED TUBING SERVICES		
	ANGSI A-12S	WELL DIAGNOSIS WITH CAMERA RUN	

## OBJECTIVES

The objective of this job is:

1. To verify the condition 5 meters above packer#1 (2,689 m MDDF) until top of fish (Top of tubing cut / PXN Plug – 3,049m MDDF)
2. To check the leak condition at depth 2,692 m MDDF
3. To confirm the top of Top of tubing cut / PXN plug condition (3,049m MDDF)
4. To perform acid stimulation on I-68 zone

## BACKGROUND

On January 2022, CT Milling operation has been conducted to mill out stuck PXN Plug at 2,697 m / 8,850 ft MDDF. After the PXN plug has been milled, handover to slickline to fish out the mill plug. However, the mill out plug was unable to retrieve. Then, PCSB has decided to perform tubing cut via slickline. The tubing cut was successful but the tubing was hanging and not drops as intended. During previous TCC on 3<sup>rd</sup> February 2022, slickline experience soft tag 1m below tubing cut and encounter HUD at depth 3,028 m / 9,936 ft WLTHF (10,000 ft MDDF / 3,049 m MDDF) just below the bottom sub packer and found out after cut debris at surrounding of 2.78" Gauge Ring after retrieve the toolstring at surface. Therefore, PCSB engaging Dimension Bid CTS to revisit to check the condition of tubing cut by running optis memory camera via CT to check the condition of tubing cut.

## WELL DATA

Input Parameter	Parameter Value
Field	Angsi-A12S
Max. Deviation (degrees)	65.5 degree @ 2,742m MDDF
Min. Restriction (inch)	<b>2.690" (XN Nipple) @ 3049.48m MDDF</b>
Tubing Specification	3-1/2" Production Tubing, 9.2# ppf, 13Cr
Type of Fluid & Density	9.4 PPG NaCl (based on data in Well Diagram)
Top of Fluid	TBA
Current Well Status	Shut In
Fracture Gradient	0.7 psi/ft (assumed)
Latest HUD	<ol style="list-style-type: none"> <li>1. HUD @ 2,730 m WLTHF (2,747 m MDDF) with 2.78" Gauge Ring.</li> <li>2. HUD @ 3,033 m WLTHF (3,049 m MDDF) with 2.72" Gauge Ring</li> </ol>

Prepared By: M. Ameerul Zaeem	Reviewed By: Kung Yee Han	Date: 16/3/2023	Rev. Rev.2	Controlled Document DB-CT-MAZ-23001	Pg. 7
----------------------------------	------------------------------	--------------------	---------------	--	----------

<b>DIMENSION BID</b>	DIMENSION BID COILED TUBING SERVICES		
	ANGSI A-12S	WELL DIAGNOSIS WITH CAMERA RUN	

### OPERATION SUMMARY

<i>Item</i>	<i>Job Description</i>	<i>Remark</i>
A	Slickline	<ol style="list-style-type: none"> <li>1. RIH for TCC</li> <li>2. RIH LIB to tag top of tubing cut</li> </ol>
B	Coiled Tubing Operation	<ol style="list-style-type: none"> <li>1. Run#1: Drift run until top of PXN Plug at 3,049 m MDDF / 10,000 ft MDDF</li> <li>2. Run#2: Run EV Camera Until top of PXN Plug at 3,049 m MDDF / 10,000 ft MDDF</li> <li>3. Run#3: Acid Stimulation on I-68 zone</li> <li>4. Contingency Run#1: Impact Hammer</li> </ol>

Prepared By: M. Ameerul Zaeem	Reviewed By: Kung Yee Han	Date: 16/3/2023	Rev. Rev.2	Controlled Document DB-CT-MAZ-23001	Pg. 8
----------------------------------	------------------------------	--------------------	---------------	--	----------

# DIMENSION BID

## DIMENSION BID COILED TUBING SERVICES



ANGSI A-12S

WELL DIAGNOSIS WITH  
CAMERA RUN

### WELL DIAGRAM

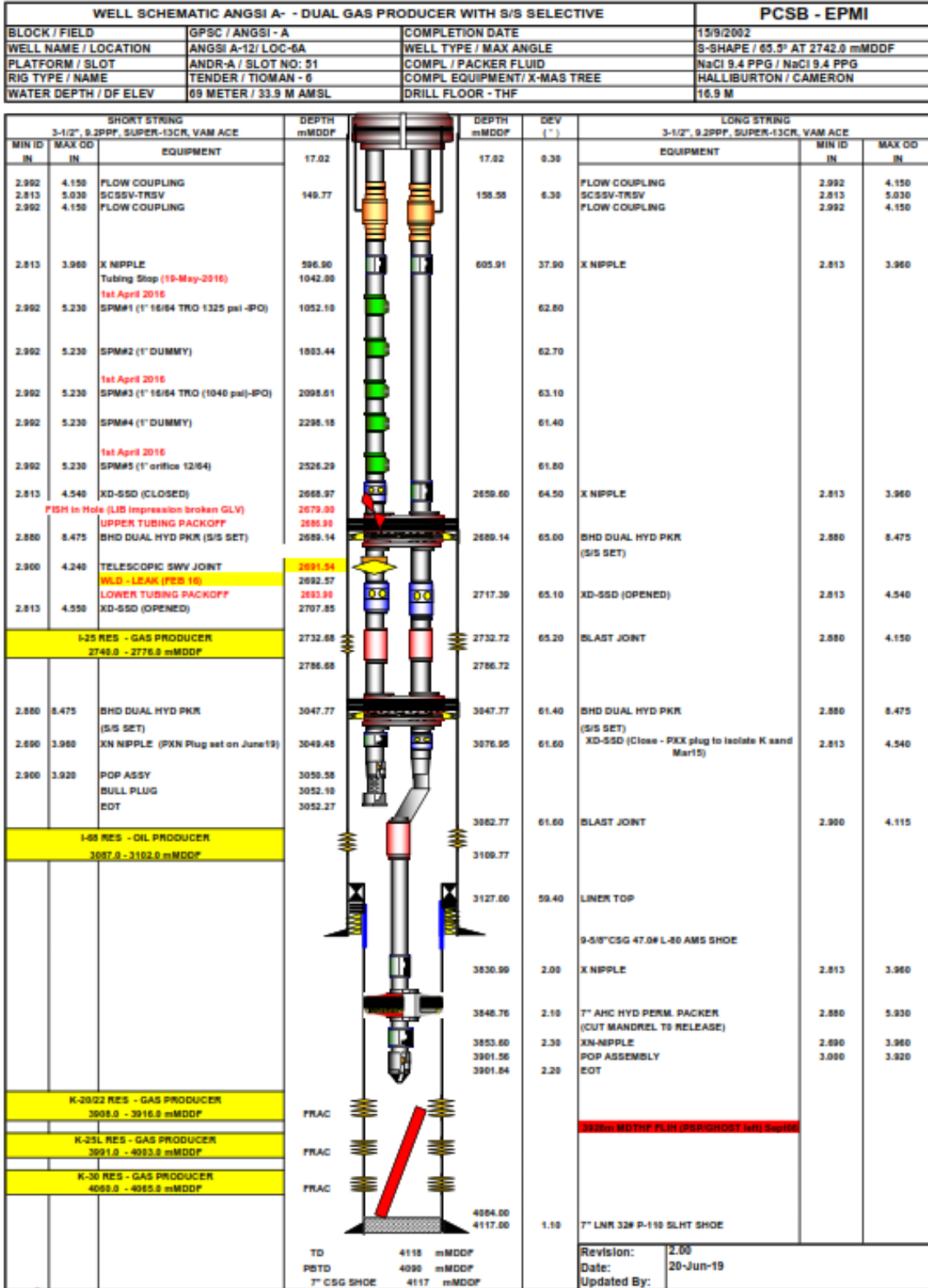

<b>DIMENSION BID</b>	<b>DIMENSION BID COILED TUBING SERVICES</b>		
	ANGSI A-12S	WELL DIAGNOSIS WITH CAMERA RUN	

**WELL 3D PLOT**

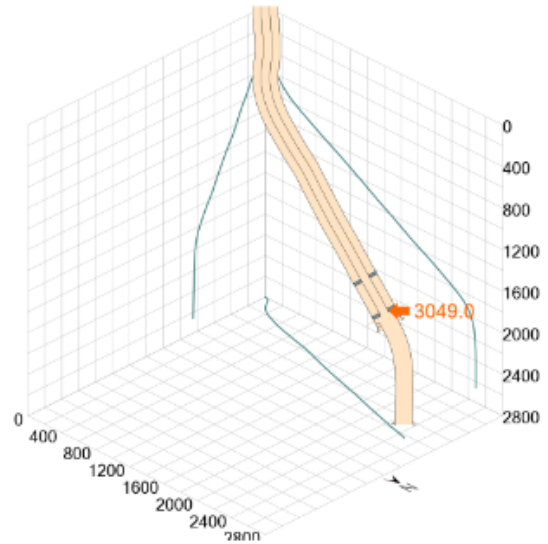
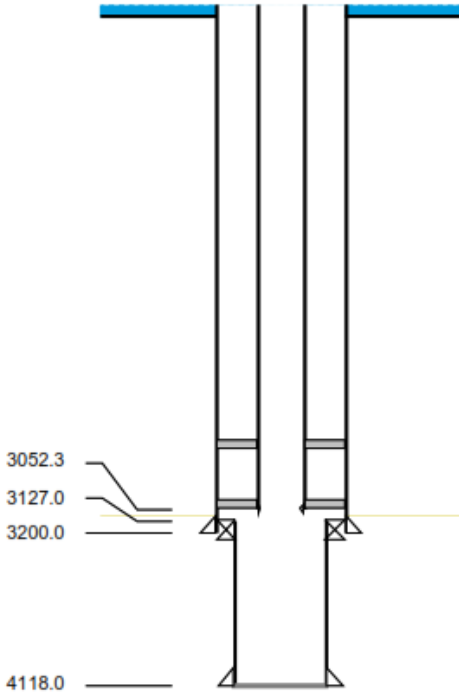

Well name: Angsi A12S  
 Total depth: 4118.0 m  
 Max Inclination: 65.3° at 2720.4 m  
 Max DLS: 6.003 °/100ft at 3444.6 m  
 Min ID: 2.992 in at surface.  
 WHP: 150 psi

Input Parameter	Parameter Value
Field	Angsi A-12S
Max. Deviation (degrees)	65.5 degree at 2,742.0m MDDF
Min. Restriction (inch)	2.69" @ 3049.48m MDDF

<b>DIMENSION BID</b>	<b>DIMENSION BID COILED TUBING SERVICES</b>				
	ANGSI A-12S		WELL DIAGNOSIS WITH CAMERA RUN		

## TREATMENT VOLUME

Tubing																
Type	External Pipe			Internal Pipe			Internal Pipe			Caps Barrel/lin (ft)	From m	To m	From ft	To ft	Length ft	Volume (bbls)
	OD (inch)	ID (inch)	W(lb /ft)	OD (inch)	ID (inch)	W(lb/ ft)	OD (inch)	ID (inch)	W(lb/ ft)							
THF to SSD#1	3 1/2	2.992	9.2							0.00870	17.02	2668.97	56	8757	<b>8701</b>	<b>76</b>
SSD#1 to Upper Tubing Packoff	3 1/2	2.992	9.2							0.00870	2668.97	2686.90	8757	8816	<b>59</b>	<b>1</b>
Upper Tubing Packoff to Leak Point	3 1/2	2.992	9.2							0.00870	2686.90	2692.87	8816	8835	<b>20</b>	<b>0</b>
Leak Point to SSD#2	3 1/2	2.992	9.2							0.00870	2692.87	2707.85	8835	8884	<b>49</b>	<b>0</b>
SSD#2 to EOT	3 1/2	2.992	9.2							0.00870	2707.85	3052.27	8884	10014	<b>1130</b>	<b>10</b>
															<b>TOTAL</b>	<b>87</b>

A-Annulus (PCP)																
Type	External Pipe			Internal Pipe			Internal Pipe			Caps Barrel/lin (ft)	From m	To m	From ft	To ft	Length ft	Volume (bbls)
	OD (inch)	ID (inch)	W(lb /ft)	OD (inch)	ID (inch)	W(lb/ ft)	OD (inch)	ID (inch)	W(lb/ ft)							
THF to Packer#1	9 5/8	8.681	47	3 1/2	2.992	9.2	3 1/2	2.992	9.2	0.04941	17.02	2689.14	56	8823	<b>8767</b>	<b>433</b>

Wellbore Area on I-25 Reservoir																
Type	External Pipe			Internal Pipe			Internal Pipe			Caps Barrel/lin (ft)	From m	To m	From ft	To ft	Length ft	Volume (bbls)
	OD (inch)	ID (inch)	W(lb /ft)	OD (inch)	ID (inch)	W(lb/ ft)	OD (inch)	ID (inch)	W(lb/ ft)							
Packer#1 to SSD#2	9 5/8	8.681	47	3 1/2	2.992	9.2	3 1/2	2.992	9.2	0.04941	2689.14	2707.85	8823	8884	<b>61</b>	<b>3</b>
SSD#2 to I-25 Top Perf	9 5/8	8.681	47	3 1/2	2.992	9.2	3 1/2	2.992	9.2	0.04941	2707.85	2740.00	8884	8990	<b>105</b>	<b>5</b>
I-25 Top Perf to Bottom Perf	9 5/8	8.681	47	3 1/2	2.992	9.2	3 1/2	2.992	9.2	0.04941	2740.00	2776.00	8990	9108	<b>118</b>	<b>6</b>
Bottom Perf to Packer#2	9 5/8	8.681	47	3 1/2	2.992	9.2	3 1/2	2.992	9.2	0.04941	2776.00	3047.77	9108	10000	<b>892</b>	<b>44</b>
															<b>TOTAL</b>	<b>58</b>

Wellbore Area on I-68 Reservoir																
Type	External Pipe			Internal Pipe			Internal Pipe			Caps Barrel/lin (ft)	From m	To m	From ft	To ft	Length ft	Volume (bbls)
	OD (inch)	ID (inch)	W(lb /ft)	OD (inch)	ID (inch)	W(lb/ ft)	OD (inch)	ID (inch)	W(lb/ ft)							
Packer#2 to EOT SS	9 5/8	8.681	47	3 1/2	2.992	9.2	3 1/2	2.992	9.2	0.04941	3047.77	3052.27	10000	10014	<b>15</b>	<b>1</b>
EOT SS to I-68 Top Perf	9 5/8	8.681	47	3 1/2	2.992	9.2				0.06130	3052.27	3087.00	10014	10128	<b>114</b>	<b>7</b>
I-68 Top Perf to Bottom Perf	9 5/8	8.681	47	3 1/2	2.992	9.2				0.06130	3087.00	3102.00	10128	10178	<b>49</b>	<b>3</b>
Bottom Perf to Top Liner	9 5/8	8.681	47	3 1/2	2.992	9.2				0.06130	3102.00	3127.00	10178	10260	<b>82</b>	<b>5</b>
Liner Top to Packer#3	7	6.366	27	3 1/2	2.992	9.2				0.02747	3127.00	3848.76	10260	12628	<b>2368</b>	<b>65</b>
															<b>TOTAL</b>	<b>81</b>

3ft Penetration - Zone I-68 Reservoir																
Type	External Pipe			Internal Pipe			Penetration (in)	Caps Barrel/lin (ft)	From m	To m	From ft	To ft	Length ft	Total Volume (bbls)		
	OD (inch)	ID (inch)	W(lb /ft)	OD (inch)	ID (inch)	W(lb/ ft)										
I-68 Reservoir			81.625				36	6.38210	3087.00	3102.00	10128	10178	<b>49</b>	<b>314</b>		
													<b>Porosity</b>	<b>0.2</b>		
													<b>Total</b>	<b>62.8</b>		
															<b>Total Treatment Volume</b>	<b>74</b>

Prepared By: M. Ameerul Zaeem	Reviewed By: Kung Yee Han	Date: 16/3/2023	Rev. Rev.2	Controlled Document DB-CT-MAZ-23001	Pg. 11
----------------------------------	------------------------------	--------------------	---------------	--	-----------

<b>DIMENSION BID</b>	DIMENSION BID COILED TUBING SERVICES		
	ANGSI A-12S	WELL DIAGNOSIS WITH CAMERA RUN	

**COILED TUBING STRING INFORMATION**

OD (in)	Spec	W/T (in)	ID (in)	Length (ft)
1.5	Tenaris HS-90	0.125	1.25	15,970
<b>CT Volume: 24.2 bbls</b>				

**CT STRING FATIGUE**

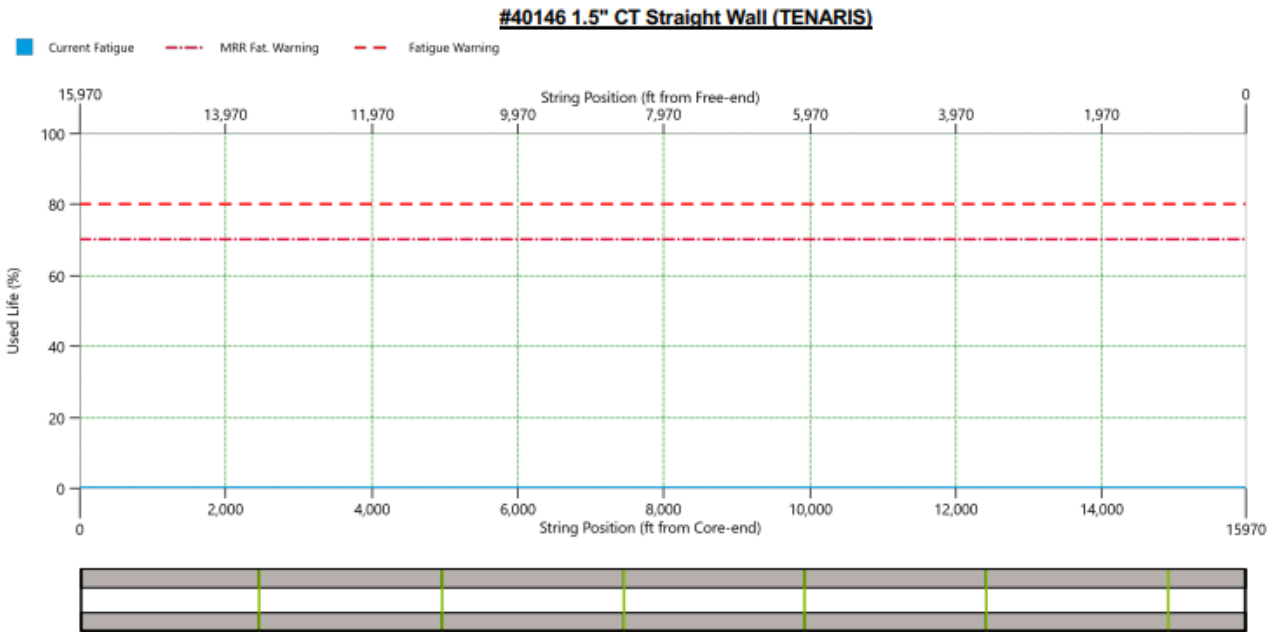

<b>DIMENSION BID</b>	<b>DIMENSION BID COILED TUBING SERVICES</b>		
	ANGSI A-12S	WELL DIAGNOSIS WITH CAMERA RUN	

**CT STRING #40146 LATEST PIPE MANAGEMENT**

Date	Job type	CT External CI Y/N	CT Internal CI Y/N	CT leng ft	CT cut ft	New CT leng ft	Update by Name	CT purged with N2 Y/N	CT plugged Y/N	Job Fatigue %	Job Corrosion %	Max Fatigue %	Cum. Corrosion %	Used String Life %
26/11/2022	Received CT String from Manufacturer			15974		15,974	Zakaria	Y	Y	0	0	0	0	0
20/1/2023	Cut 4ft & spooling into DDF			15974	4	15,970	Zakaria	N	N	0.33	0.5	0.33	0.5	0.83
23/1/2023	Pump CI and purge with N2		Y	15,970		15,970	Zakaria	Y	Y	0.33	0	0.33	0.5	0.83
23/1/2023	Apply external corrosion inhibitor & cover with canvas	Y		15,970		15,970	Zakaria	Y	Y	0.33	0	0.33	0.5	0.83

Based on above pipe management;

- Current CT Fatigue Life is 0.33 %
- Current String Used Life is 0.83 %
- Current Running Footage in Chrome Completion is 0 ft
- Current Total Running Footage is 0 ft

Based on Dimension Bid Standard Operating Procedure (SOP) of Pipe Management for Chrome Completion:

- Max Running Footage in Chrome Completion is **200,000 ft**

Based on Dimension Bid Standard Operating Procedure (SOP) of Pipe Management to junk the CT:

- **100%** of CT String Life reached
- Experienced two separate pinholes for the same CT String
- CT String exceed max working pressure

Prepared By: M. Ameerul Zaeem	Reviewed By: Kung Yee Han	Date: 16/3/2023	Rev. Rev.2	Controlled Document DB-CT-MAZ-23001	Pg. 13
----------------------------------	------------------------------	--------------------	---------------	--	-----------

### PROCESS FLOW DIAGRAM

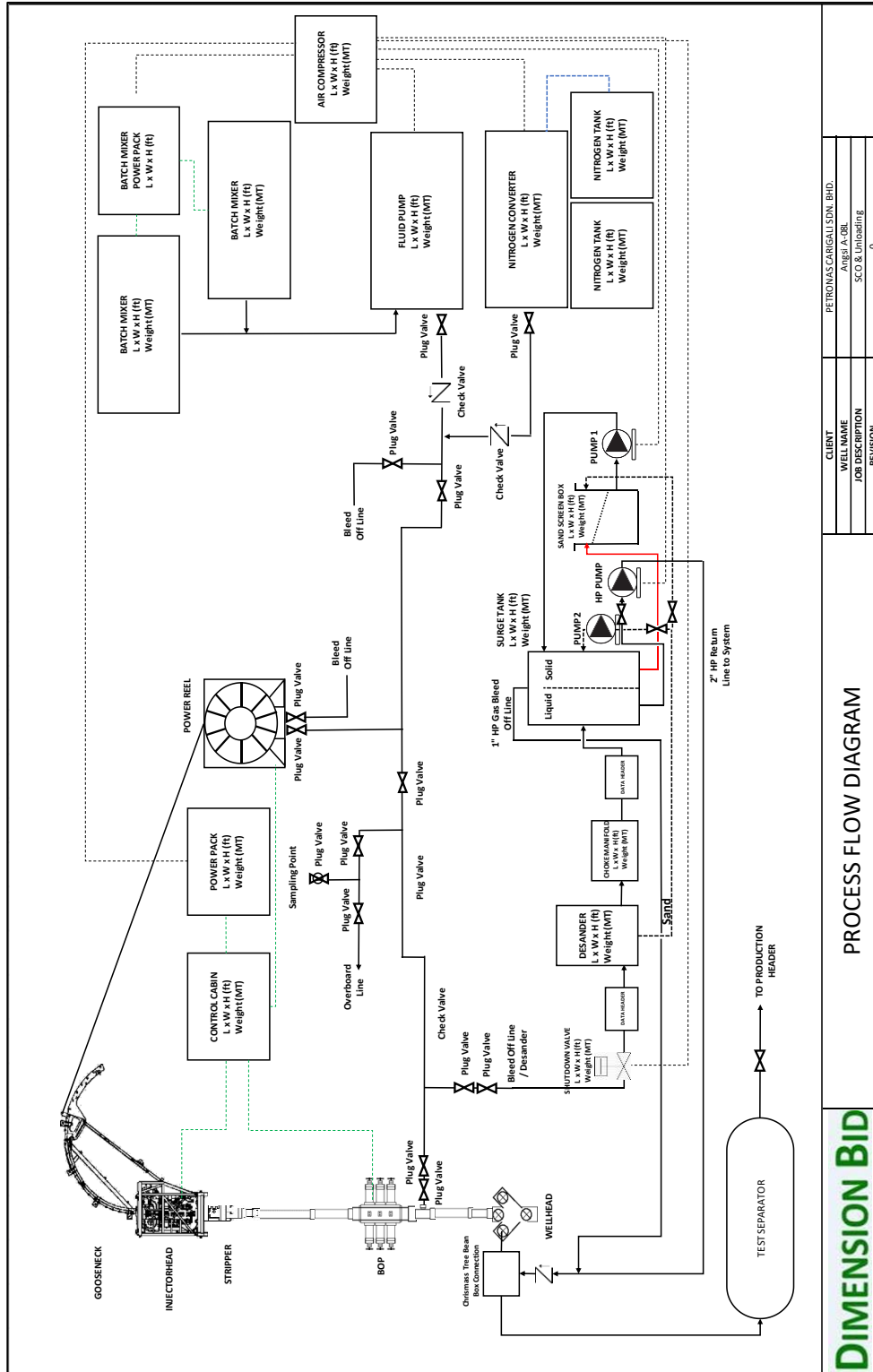

**DIMENSION BID**

PROCESS FLOW DIAGRAM

CLIENT	PETRONAS CARIGALI SDN. BHD.
WELL NAME	ANGSI A-12S
JOB DESCRIPTION	SCO & Unloading
REVISION	0

<b>DIMENSION BID</b>	DIMENSION BID COILED TUBING SERVICES		
	ANGSI A-12S	WELL DIAGNOSIS WITH CAMERA RUN	

## SAFETY OPERATIONAL PROCEDURES

**Prior to commencement of the Coiled Tubing / Bull-heading operation, a pre-job meeting will be held. This should be attended by the following parties as a minimum:**

OIM, WSS, Coiled Tubing Supervisor, Representatives of other service companies involved and others as necessary.

**Safety meetings should be held at the start of every shift and risk assessments must be evaluated during this time. Tool box talks should be held immediately prior to the job execution.**

**Note: The safety meeting must be driven by DB Supervisor addressing the following topics as a minimum:**

1. Muster point.
2. Take list of personnel on site (Head count)
3. All personnel should review and be familiar with escape routes and emergency procedures.
4. Describe the **job objective, fluids and volumes to be pumped, pressures expected** during the job, and others.
5. Review **Dimension Bid Operations Policy and Procedure Manual**.
  - 5.1. Ensure at all steps carried out during the operations comply with this Manual.
  - 5.2. Management of change **MUST** be applied any time there is a need to deviate from the steps contained this procedure.
  - 5.3. A document **MUST** be created describing each the step of the deviation. This document shall also include the deviation Risk Assessment and it **MUST** be approved and signed by PCSB – Head of Well Intervention and Dimension Bid Operations Manager.
6. Exercise stops work authority if unsafe condition occurs and assess situation with all team members, resume operation after mitigation plan is in place.
7. Personnel responsibilities throughout the job.
8. Spills, fire, blow out, unexpected well behaviour.
9. Emergency shower station and eye wash station location.
10. Trapped potential energy such as pressure or coiled tubing stiffness.
11. Prepare related Job Hazard Analysis (JHA) prior commencement of any work, get approval from Client Site Representative (CSR) and review it with all personnel involved as well as to review Risk Assessment.
12. Discuss the well H<sub>2</sub>S, CO<sub>2</sub>, Hg (Mercury) content (if applicable).
13. Adhere all **PCSB Zeto Rules** and other guidelines.
14. Take a physical count of inventory and make sure all required materials are available on site.
15. **Barricade** the work area and display the appropriate **warning sign**.
16. On chemical mixing and handling; all personnel involved shall hold **safety meeting** and review **Safety Data Sheet** (SDS).
  - 16.1. Personnel involve during chemical handling shall be briefed by DB Chemical Specialist onsite and extra precautions must be taken. All SDS must be available on site and reviewed prior chemical handling.
  - 16.2. All non-essential personnel shall stay away from mixing site.
  - 16.3. Use PPE including respirators, hard hats, eye protection and steel-toed boots.
  - 16.4. Verify if there is any **dead Volume** in the mixing tanks and adjust volumes to account for non-usable volume in the blender / mix tank.

Prepared By: M. Ameerul Zaeem	Reviewed By: Kung Yee Han	Date: 16/3/2023	Rev. Rev.2	Controlled Document DB-CT-MAZ-23001	Pg. 15
----------------------------------	------------------------------	--------------------	---------------	--	-----------

<b>DIMENSION BID</b>	<b>DIMENSION BID COILED TUBING SERVICES</b>		
	ANGSI A-12S	WELL DIAGNOSIS WITH CAMERA RUN	

- 16.5. Consider wind direction and note all trip hazards in the mix / pumping area.
- 16.6. Prior to mixing chemicals, clean and verify the tank/batch mixer and lines are free of any debris and or contaminants.
- 16.7. In case of spill; wash the place where any chemical has been spilt with available spill kit.
- 16.8. Take care to prevent leakage due to ejection from valves, fittings, flanges, or other joints flexible chemical hoses and pumps. Never repair the equipment during transfer into mixing tank/container.
17. Take reading of Shut in / Flowing Tubing Head Pressure (SI/FTHP), Casing Head Pressure (CHP) and fluid sample (if available) prior to operation.
18. Check gas lift condition and capability with Site Operation Representative (SOR).
19. Ensure fitness prior to perform duties assigned.
20. Ensure all barriers are in place and followed.

### **HEALTH, SAFETY & ENVIRONMENT**

1. Evaluate possible risks to arise during the job execution.
2. Evaluate risk assessment. Report any abnormal or insecure condition on site, taking into account all the steps or procedures to follow. Discuss with PCSB HSE coordinator, the execution or suspension of the job.
3. Review SDS of each product that will be used. Verify that all personnel on location handling toxic or corrosive products have the proper PPE.
4. Review the contingency plan for spills.
5. Do not vent / release any hydrocarbons from the well to atmosphere. Returns from the well should be handled safely by Flowback Company.
6. Prior to DB personnel walking on upper deck, DB Supervisor to inspect upper deck and ensure that the area it is in good condition (Gratings, Hatches, etc.)

Prepared By: M. Ameerul Zaeem	Reviewed By: Kung Yee Han	Date: 16/3/2023	Rev. Rev.2	Controlled Document DB-CT-MAZ-23001	Pg. 16
----------------------------------	------------------------------	--------------------	---------------	--	-----------

<b>DIMENSION BID</b>	DIMENSION BID COILED TUBING SERVICES		
	ANGSI A-12S	WELL DIAGNOSIS WITH CAMERA RUN	

## EQUIPMENT RIG UP PROCEDURE

Conduct safety meeting with all personnel on location detailing the program, pressure limitations, and personnel responsibilities, well control emergency drill and safety precautions.

1. Spot the equipment accordingly to space availability, ensure reel position is aligned with the well.
2. Spot jacking frame at available space with sufficient height and crane capacity to rig up the injector head and gooseneck.
3. Rig up the 4" LP hoses from fluid storage tanks to batch mixer and single pump unit
4. Rig up 2" HP treating line as per DB Technical Standard from single pump unit and N2 converter unit to coiled tubing reel manifold. Include bleed off line on both lines as well.
5. Install correct wellhead crossover on the wellhead. Ensure well is fully secure and record the MV and CV turns.
6. Install Blowout Preventer (BOPs):
  - 6.1. Rig up Single BOP with necessary length of risers on top of the wellhead crossover.
  - 6.2. Rig up Combi BOP with flow tee above the risers
  - 6.3. Hook up BOP hoses and conduct function test for each ram.
7. Rig up 2" kill line from single pump unit line to BOP kill port
8. Rig up flow back line from flow tee to Choke manifold -> desander unit / production system
9. Spot injector head assembly with jacking frame on top of wellhead area. Ensure the gooseneck is aligned with the reel position
10. Inspect the chain and gripper block condition and ensure the alignment is correct
11. Rig up the following hydraulic hoses:
  - 11.1. From CT Power Pack to CT Control Cabin
  - 11.2. From CT Power Pack to CT Injector hose reel
  - 11.3. From CT Control Cabin to CT Reel
  - 11.4. From CT Control Cabin to CT BOPs
  - 11.5. From CT Power Pack to Jacking Frame
12. Perform EMC 1 for all equipment. Start up and run all equipment for few minutes.
13. Jack up CT control cabin.
14. Function test both BOP rams.

**\*Observe indicator pin to confirm that all rams are in good working condition.**
15. Install the stab-in-guide on the CT then stab the string into injector head.
16. Make up the CT connector and perform pull test at least 15,000 lbs as per DB SOP. This test to be recorded in OrionNet.

**\*Do not perform pull test more than 80% from CT Limit.**
17. Install pressure test plate onto the CT connector.
18. Circulate the string & flowback line with water until clean return is seen prior to proceed with pressure test CT Connector.
19. Pressure up the CT string to 5,000 psi gradually by 500 psi increment then hold for 10 minutes. Pressure test acceptance criteria:

Prepared By: M. Ameerul Zaeem	Reviewed By: Kung Yee Han	Date: 16/3/2023	Rev. Rev.2	Controlled Document DB-CT-MAZ-23001	Pg. 17
----------------------------------	------------------------------	--------------------	---------------	--	-----------

<b>DIMENSION BID</b>	<b>DIMENSION BID COILED TUBING SERVICES</b>		
	ANGSI A-12S	WELL DIAGNOSIS WITH CAMERA RUN	

- 19.1. For low pressure at 300 psi:  
**Acceptance criteria: No visible leaks. Pressure drop is less than 10% (above 270 psi) over 5-minutes test interval after the pressure stabilizes.**
- 19.2. For high pressure at 5,000 psi:  
**Acceptance criteria: No visible leaks. Pressure drop is less than 10% (above 4,500 psi) over the 15- minutes test interval after the pressure stabilizes**
20. Open the needle valve to release the pressure slowly.
21. Make up the BHA onto the string as per BHA diagram provided.
22. Use the jacking frame to pick up the injector and risers then connect to the Combi BOP. Secure down the injector assembly with chains.
23. Measure the following length to set the CT depth:

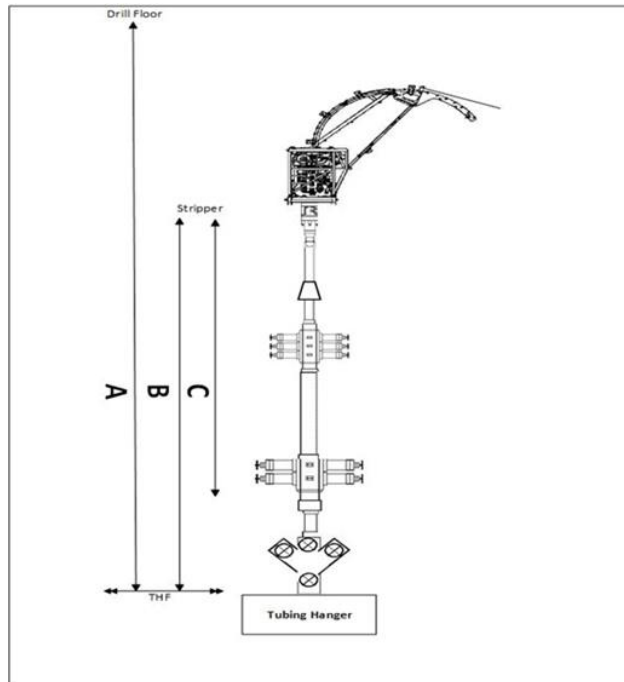

Distance	Length (ft)
<b>A:</b> Tubing Hanger (THF) to RKB	
<b>B:</b> Tubing Hanger (THF) to Stripper	
<b>C:</b> BHA Length	

\*The reference depth is at the tip of BHA

24. Pick up CT and tag the stripper to set CT depth based on this calculation "A-B+C".

Prepared By: M. Ameerul Zaeem	Reviewed By: Kung Yee Han	Date: 16/3/2023	Rev. Rev.2	Controlled Document DB-CT-MAZ-23001	Pg. 18
----------------------------------	------------------------------	--------------------	---------------	--	-----------

<b>DIMENSION BID</b>	DIMENSION BID COILED TUBING SERVICES		
	ANGSI A-12S	WELL DIAGNOSIS WITH CAMERA RUN	

## EQUIPMENT PRESSURE TESTING PROCEDURE

Conduct safety meeting with all personnel on location detailing the program, pressure limitations, and personnel responsibilities; well control emergency drill and safety precautions. Refer the following procedure to pressure test BOP Body, Blind Ram, Surface Line and Wellhead connection.

1. Isolate the line to Coiled Tubing. Double confirm the valve is closed.
2. Fill and pressure test the treating line with water to 500 psi and hold for 5 minutes. Inspect the lines for leaks and observe for any pressure drop.
3. Increase pressure to 3,000 psi and hold for 10 minutes. Inspect the lines for leaks and observe for any pressure drop.
4. Fill the pressure control equipment and ensure air is vented from the system by leaving the blind ram and blind ram equalizing valves open.
5. Close blind ram and equalizing valve. Pressure up the surface lines, BOP body, blind rams and wellhead connection to 500 psi then increase gradually to 3000 psi through the kill line, hold for 10 minutes. Inspect the lines for leaks and observe for any pressure drop. PT acceptance criteria as per below:

5.1. For low pressure at 500 psi:

**Acceptance criteria: No visible leaks. Pressure drop is less than 10% (above 450 psi) over 5-minutes test interval after the pressure stabilizes.**

5.2. For high pressure at 3,000 psi:

**Acceptance criteria: No visible leaks. Pressure drop is less than 10% (above 2,700 psi) over the 15- minutes test interval after the pressure stabilizes**

6. Once test complete, open blind ram pressure equalizing port then bleed off any residual pressure and open the blind rams.

Conduct safety meeting with all personnel on location detailing the program, pressure limitations, and personnel responsibilities; well control emergency drill and safety precautions. Refer the following procedure to pressure test BOP Body, Blind Ram, Surface Line and Wellhead connection.

1. Fill up the CT string and stack up until leak can be seen at stripper.
2. Energize the stripper and begin pressure test the complete stack up (CT string, stripper, CT stack and risers) to 3,000 psi against Crown Valve, hold for 10 minutes.
3. Bleed off pressure inside CT to 0 psi to test the Double Flapper Check Valve to 1,500 psi and hold for 10 minutes. Do not apply pressure more than CT Collapse Pressure (1500 psi).
4. Bleed off the pressure from BOP kill port side.  
**\*Step 4-8 can be neglected if pipe ram has been pressure tested prior to the job.**
5. Place CT string across pipe ram then close the ram.
6. Open pipe ram equalizing valve then fill up the BOP slowly.
7. Close the equalizing valve and begin pressure test the pipe ram to 3,000 psi, hold for 10 minutes.
8. When the tests are complete, bleed off the pressure.

Prepared By: M. Ameerul Zaeem	Reviewed By: Kung Yee Han	Date: 16/3/2023	Rev. Rev.2	Controlled Document DB-CT-MAZ-23001	Pg. 19
----------------------------------	------------------------------	--------------------	---------------	--	-----------

<b>DIMENSION BID</b>	DIMENSION BID COILED TUBING SERVICES		
	ANGSI A-12S	WELL DIAGNOSIS WITH CAMERA RUN	

## CT STRING MANAGEMENT DURING OPERATION

1. When RIH CT String in **13CR Chrome Completion**, there are few mitigations plan need to be executed throughout the CT Operation to ensure we avoid CT String Failure event. However, this mitigation also should be applied in every CT job regardless of any grade of completion for better execution.
2. Visually inspect the overall CT String prior our 1<sup>st</sup> run.
3. Ensure to check the end of CT condition when making up connector for the 1<sup>st</sup> run. Below is the parameter that we need to verify to town prior making up the connector:
  - a. Record overall wall thickness from the end of CT up to 3-5ft.
  - b. Visually inspect if there is any flat surface / ovality.

Please proceed cut the CT till the recommended wall thickness is reached. This visual inspection needs to be done for **every run**.
4. As per current Dimension Bid standard, we need to cut the CT string of approximately **100 ft**. The purpose of this method is to:
  - a. Shift the fatigue of our CT String
  - b. To reduce the possibility of flat surface due to abrasion effect at the whip end of CT.
5. Throughout the CT Operation, we need to lubricate the annulus side of CT string with our friction reducer solution.
6. After every **1,000 ft** of running, please ensure to;
  - a. Perform pull test
  - b. Pump at least **2 bbls** of friction reducer solution whether through CT or kill port is subject to the tubing head pressure (THP).
7. For additional precaution and by referring to the Angsi A-12S survey deviation below, we need to;
  - a. Monitor the weight frequently
  - b. Perform additional pull test
  - c. Pump additional 2 bbls of friction reducer solution for every time pull test is conducted or every 1000 ft.

Depth Interval (MDDF)	Deviation Range (deg)
643 – 3,357	40 - 70

Please include all these precautionary steps into each run to ensure we reduce the abrasion effect between our CT String & production tubing.

Prepared By: M. Ameerul Zaeem	Reviewed By: Kung Yee Han	Date: 16/3/2023	Rev. Rev.2	Controlled Document DB-CT-MAZ-23001	Pg. 20
----------------------------------	------------------------------	--------------------	---------------	--	-----------

<b>DIMENSION BID</b>	DIMENSION BID COILED TUBING SERVICES		
	ANGSI A-12S	WELL DIAGNOSIS WITH CAMERA RUN	

## OPERATIONAL PROCEDURE

### SLICKLINE OPERATION

All depths specified below are in m-MDDF (**Drill floor to THF is 16.9-m as per well schematic**)

1. Slickline to conduct TCC run to ensure the tubing path is clear from obstruction and record the min ID of the tubing:

<i>Drift ID</i>	<i>Unit</i>

2. If fluid level or encountered HUD is found, record it in the following table:

<i>Description</i>	<i>Depth (m)</i>
Fluid level	
HUD	

3. Slickline to run LIB and tag below tubing cut (TOF or PXN Plug) previously slickline encounter HUD @ 2,730 m WLTHF (2,747 m MDDF) with 2.78" Gauge Ring. But, they managed to tag HUD @ 3,033 m WLTHF (3,049 m MDDF) with 2.72" Gauge Ring (November 2022). Report the finding to WSS and CTU Supervisor.
4. Once completed, rig down Slickline unit and handover well to CT operation.

Prepared By: M. Ameerul Zaeem	Reviewed By: Kung Yee Han	Date: 16/3/2023	Rev. Rev.2	Controlled Document DB-CT-MAZ-23001	Pg. 21
----------------------------------	------------------------------	--------------------	---------------	--	-----------

<b>DIMENSION BID</b>	DIMENSION BID COILED TUBING SERVICES		
	ANGSI A-12S	WELL DIAGNOSIS WITH CAMERA RUN	

**COILED TUBING OPERATION – RUN#1 DRIFT RUN UNTIL TOP OF PXN PLUG AT 3,049 M MDDF / 10,000 FT MDDF**

All depths specified below are in m-MDDF (Drill floor to THF is 16.9-m as per well schematic)

Conduct safety meeting with all personnel on location detailing the program, pressure limitations, personnel responsibilities, emergency well control drill, and safety precautions.

1. Rig up CTU and surface line on Angsi-A platform as per Site Visit Report:
  - 1.1. Review JHA and risk assessment with all personnel involve in the rig up operation. Please send a copy of JHA to Engineer in Charge.
  - 1.2. Lift up CT unit using crane and spot on platform.
  - 1.3. Rig up CT package and surface treating line.
  - 1.4. Rig up 2” kill line to BOP kill port.
  - 1.5. Rig up 2” flexible hose from pumping tee.
  - 1.6. Ensure pump volume, pump rate, N2 rate, circulating pressure, well head pressure, weight is synchronise with OrionNet DAS.
  - 1.7. Pig CT with treated injection water to ensure no debris is inside CT. **Record CT tubing volume in treatment report.**
  - 1.8. Make up the **CT End Connector**.
  - 1.9. Install the Pull and Pressure Test Sub.
  - 1.10. Perform Pull Test on the CT End Connector **to 15,000 lbf** and record this in OrionNet.
  - 1.11. Perform Pressure Test on CT End Connector. Pumping treated sea water through the CT, apply low pressure test of **300 psi for 5 minutes** and high-pressure test of **5,000 psi for 15 minutes** after stabilization. Record the pressure test.

**Note: Do not perform pull test more than 80% CT. Consult with town if require.**

1.11.1. For low pressure:

**Acceptance criteria: No visible leaks. Pressure drop is less than 10% (above 270 psi) over 5-minutes test interval after the pressure stabilizes.**

1.11.2. For high pressure:

**Acceptance criteria: No visible leaks. Pressure drop is less than 10% (above 4,500 psi) over the 15- minutes test interval after the pressure stabilizes.**

2. Prepare 100 bbls of Treated Injection Water, TIW as per recipe below:

Treated Injection Water (TIW)				100	BBL	Description
Seq.	Product	Concentration	Volume			
1	Injection Water	992 gptg	4,166	gal	Base Fluid	
2	ACM H2S Clear 200	2 gptg	8	gal	CO2 & H2S Corrosion Inhibitor	
3	ACM BACT 200	2 gptg	8	gal	Micro Biocide Control	
4	ACM OXYFREE 100	2 gptg	8	gal	Oxygen Scavenger	
5	MESB NE-Surf 200	2 gptg	8	gal	Non-Emulsifier Surfactant	

**Mixing Instruction:**

1. Prepare injection water in the mixing tank.
2. Add ACM H2S Clear 200 & ACM OXYFREE 100 into the tank and circulate the mixture.
3. Add ACM BACT 200 & NE-Surf 200 into the tank and circulate the mixture until homogenous.

Prepared By: M. Ameerul Zaeem	Reviewed By: Kung Yee Han	Date: 16/3/2023	Rev. Rev.2	Controlled Document DB-CT-MAZ-23001	Pg. 22
----------------------------------	------------------------------	--------------------	---------------	--	-----------

<b>DIMENSION BID</b>	DIMENSION BID COILED TUBING SERVICES		
	ANGSI A-12S	WELL DIAGNOSIS WITH CAMERA RUN	

**Note:** The above recipe is for 100bbls of TIW. Please prepare another batch of TIW once needed.

3. Prepare 50bbls of D801 Cleanout Gel as per recipe below:

D801 Cleanout Gel				50	BBL	Description
Seq.	Product	Concentration		Volume		
1	Injection Water	992	gptg	2,083	gal	Base Fluid
2	D801 Gel	40.5	pptg	85	lbs	Gelling Agent
<b>Mixing Instruction:</b>						
1. Prepare injection water in the mixing tank.						
2. Add D801 Gel into the tank and circulate the mixture until homogenous.						

**Note:** The above recipe is for 50bbls of D801 Gel. Please prepare another batch of D801Gel once needed.

4. Make up 2-1/8" Multi-Jet Nozzle tool as per **BHA#1: 2-1/8" Multi Jet Nozzle c/w 2.29" Fluted Centralizer in Appendix 1.**
5. Perform function test of the Multi-Jet Nozzle to determine at which pump rate and pressure of the tool. Record the data in the table below, do not exceed 5,000psi.

Flow rates (bpm)	Pressure (psi)	Remark
0.3		
0.5		
0.6		
0.7		
0.8		
0.9		
1.0		
1.1		
1.2		
1.3		

6. Pick up CT and tag the stripper with the BHA.
7. Make up the Injector Head and Stripper to the stack up.
8. CT stack up pressure test against Wellhead Swab valve. Pumping treated injection water through the CT, apply low pressure test of **300 psi for 5 minutes** and high-pressure test of **3,000 psi for 15 minutes** after stabilization. Record the pressure test. Record test on a chart. Upon successful pressure test, bleed off pressure via Pump-In Sub.
- 8.1. For low pressure:  
**Acceptance criteria: No visible leaks. Pressure drop is less than 10% (above 270 psi) over 5-minutes test interval after the pressure stabilizes.**
- 8.2. For high pressure:  
**Acceptance criteria: No visible leaks. Pressure drop is less than 10% (above 2,700 psi) over the 15- minutes test interval after the pressure stabilizes.**
9. Pressure test the BHA Check Valve. With **3,000 psi** in the CT stack up, bleed off the stack up pressure to **1,500 psi** via pump-in sub; and bleed off pressure in the CT to zero (0) psi via reel manifold.
- 9.1. Acceptance criteria: **Pressure drop is less than 10% (above 1,350 psi) over the 15- minute test interval after the pressure stabilizes.** Observe for any pressure changes in the stack up. If the BHA check valve is not holding, proceed to replace the MHA; do not RIH with leaking check valve; repeat steps 8.2 and 9.
10. Upon successful test, bleed off the pressure in the CT stack up to zero through the pump-in sub.
11. Zero both depth counters at reference point.

Prepared By: M. Ameerul Zaeem	Reviewed By: Kung Yee Han	Date: 16/3/2023	Rev. Rev.2	Controlled Document DB-CT-MAZ-23001	Pg. 23
----------------------------------	------------------------------	--------------------	---------------	--	-----------

<b>DIMENSION BID</b>	DIMENSION BID COILED TUBING SERVICES		
	ANGSI A-12S	WELL DIAGNOSIS WITH CAMERA RUN	

12. Confirm all wellhead and BOP valves are in open position via physical check.
  - 12.1. Prior to opening the wellhead valve pressure up above master valves to a pressure equal to the expected shut-in wellhead pressure.
  - 12.2. Count wellhead valves turns while opening and record it the treatment report for reference in future.
  - 12.3. Manipulate surface valve to the following position:

Valve	Position
Reel Manifold	OPEN
Flow Cross Return Valve (Cetco lines)	OPEN
Wing Valve	CLOSE

13. Start RIH CT to **3,039 m MDDF / 9,968 ft MDDF (10m above top of tubing cut / PXN Plug)** while pumping **TIW** at minimum rate permissible.
  - 13.1. Refer to CT Tubing Force simulation (Orpheus modelling), refer Appendix III.
  - 13.2. Conduct pull test as per for every 300 m (1,000 ft), use CT Fatigue graph as reference. **Ensure the CT Fatigue graph is available at location before RIH. Record RIH, Hanging and POOH weight in treatment report.**
  - 13.3. Maximum CT speed RIH is **30-50 ft/min.**
  - 13.4. Slow down CT speed to **10 ft/min**, 50 ft before and after passing through completion accessories.
  - 13.5. Slow down CT speed to 10 ft/min, 50 ft before and after passing through previous slickline HUD at **2,747 m MDDF / 9,012 ft MDDF** (November 2022).
  - 13.6. Closely observe weight indicator in control cabin while RIH.
  - 13.7. Observe return all the times.
  - 13.8. Regularly inform WSS on job status at all times.
  - 13.9. Do not exceed operating safety limits **5,000 psi.**
  - 13.10. If the well condition differs from original job design, contact appropriate personnel in charge before proceeding.
  - 13.11. At all time, while RIH, the injector torque control shall be set at the minimum pressure required to move the CT at specified speed.
14. If CT encounters HUD, pick up CT back to 30 ft above HUD. Increase pump rate to maximum pump rate achievable (with reference to pump rate in **Step 5**) to start penetrate the HUD. Continue circulating until good return establish at surface. (Proceed to **steps 16** if CT did not encounter any HUD)

**Note:** Pump rate can be increase to max 1.3 bpm or until reach maximum circulating pressure of 5,000 psi.

Prepared By: M. Ameerul Zaeem	Reviewed By: Kung Yee Han	Date: 16/3/2023	Rev. Rev.2	Controlled Document DB-CT-MAZ-23001	Pg. 24
----------------------------------	------------------------------	--------------------	---------------	--	-----------

<b>DIMENSION BID</b>	<b>DIMENSION BID COILED TUBING SERVICES</b>		
	ANGSI A-12S	WELL DIAGNOSIS WITH CAMERA RUN	

14.1. Continue penetrate HUD as per below table until **3,049 m MDDF / 10,000 ft MDDF (PXN Plug)**.

No.	Stage	Fluid	Liquid Rate	Total Liquid	N2 Rate (if require)	CT Speed	Duration	Depth	Remarks
			BPM	Bbl	SCF/M	ft/min	Minute	m	
1	CT at 10m above HUD	TIW	1.0	0.0	300	0	0	10m above HUD	Establish return on surface
2	Penetrating HUD/Fill	TIW	1.0	10.0	300	10	10	HUD + 30m	Monitor return & CT weight on surface
3	Circulate	D801 Gel	1.0	5.0	300	0	5	Stationary CT	Provide suspension to the fill and lift to surface
Pull Test 10m									
4	RIH to HUD and Penetrate HUD/Fill	TIW	1.0	10.0	300	10	10	HUD + 30m	Monitor return & CT weight on surface
5	Circulate	D801 Gel	1.0	10.0	300	0	10	Stationary CT	Provide suspension to the fill and lift to surface
Pull Test 10m									
<b>Repeat steps 1-5 until reach 2,680 m / 8,793 ft MDDF (10m above leak point area)</b>									
At <b>2,680 m / 8,793 ft MDDF (1<sup>st</sup> logging depth)</b> , record running hour									
<b>Repeat steps 1-5 until reach PXN Plug depth 3,049 m MDDF / 10,004 ft MDDF</b>									
<b>Flag CT #1</b> once confirm tag top of tubing cut / PXN Plug depth <b>3,049 m / 10,004 ft MDDF</b> . Record running hour and <b>reset mechanical &amp; electrical depth counter</b>									
6	Circulate	D801 Gel	1.0	65	300	0	65	Stationary CT	Provide suspension to the fill and lift to surface
7	Bottoms up	TIW	1.0	131	300	0	131	Stationary CT	Hole cleaning stage. 1.5 X CT/Tubing Anulus Volume
Collect sample at return and hand over to EV Engineer									
Pick up CT to depth <b>3,044 m / 9,984 ft MDDF (5m above top of tubing cut / 2<sup>nd</sup> logging depth)</b> and <b>flag CT #2</b>									
Pick up CT to depth <b>2,680 m / 8,793 ft MDDF (10m above leak point at 2,692.57 m MDDF/ 1<sup>st</sup> logging depth)</b> and <b>flag CT #3</b>									
8	POOH to surface	TIW	0.3	15	0	10	50	To surface	Monitor return on surface

15. If CT encountered hard obstruction, proceed to pick up CT 10m above the obstruction and circulate at least 2x bottom up with TIW until clear return is observe on surface before proceed with the following steps:

Prepared By: M. Ameerul Zaeem	Reviewed By: Kung Yee Han	Date: 16/3/2023	Rev. Rev.2	Controlled Document DB-CT-MAZ-23001	Pg. 25
----------------------------------	------------------------------	--------------------	---------------	--	-----------

<b>DIMENSION BID</b>	DIMENSION BID COILED TUBING SERVICES		
	ANGSI A-12S	WELL DIAGNOSIS WITH CAMERA RUN	

15.1. RIH and slack off CT not exceeding 1,000 lbf on top of the obstruction and attempt to jet on the obstruction. If no success proceeds to mix **10 bbls of 15% HCl acid and Neutralization Fluid** as per the following recipe:

15% HCl (Main Treatment)				10	BBL	Description
Seq.	Product	Concentration		Volume		
1	Injection Water	419	gptg	176	gals	Base Fluid
2	ACM CORR 400	4	gptg	2	gals	Acid Corrosion Inhibitor
3	MESB NE 200	4	gptg	2	gals	Non-Emulsifier
4	ACM Surf 210	3	gptg	1	gals	Surfactant
5	Ammonium Chloride	417	pptg	175	lbs	Clay Stabilizer
6	ACM Iron 300	25	pptg	11	lbs	Iron Sequestering
7	ACM Iron 200	15	gptg	6	gals	Iron Control
8	33% HCl	419	gptg	176	gals	Raw Acid
9	MESB MS 300	100	gptg	42	gals	Mutual Solvent

**Mixing Instruction:**

1. Fill up tank with injection water.
2. Add additives as per above sequence.
3. Agitate until mixture is homogenous.

Neutralization Fluid				10	BBL	Description
Seq.	Product	Concentration		Volume		
1	Injection Water	976	gptg	410	gal	Base fluid
2	Soda Ash	500	pptg	210	lbs	Neutralization fluid

**Mixing Instruction:**

1. Prepare injection water in the mixing tank.
2. Mix soda ash into tank and agitate until mixture is homogenous.

15.2. Upon completion mixing 15% HCl acid, proceed to jet 5 bbls of 15% HCl on top of the obstruction while attempt to pass through the obstruction. If no progress, proceed with **step 15.3**.

15.3. If no success during jetting HCl acid, proceed to spot another 5 bbls of 15% HCl on top of obstruction and pick up CT at least **550m** above the obstruction depth to soak the acid for 2 hours. After completed soaking, proceed to RIH to pass through the obstruction while pumping nitrified TIW. If no success consults town prior for way forward.

15.4. During circulation, if acid return observes on surface return line, inject soda ash using chemical injection pump on the surface return line to neutralize the acid.

15.5. If there is no HUD detected, proceed to **step 16**.

16. At depth **2,680m MDDF / 8,793ft MDDF** (10m above leak point at 2,693 m MDDF). Record the running hour from surface until **2,680m MDDF**. Record the following and include in daily report.

Depth	Running Hour (hr:min)
0 - 2,683 m MDDF	

17. Continue RIH until **3,039 m MDDF / 9,967 ft MDDF (10m above PXN Plug)**, stop CT and conduct pull test of 10m/30ft with pumping rate 0.3BPM and record the pulling weight both static and dynamic (**IMPORTANT**).

Prepared By: M. Ameerul Zaeem	Reviewed By: Kung Yee Han	Date: 16/3/2023	Rev. Rev.2	Controlled Document DB-CT-MAZ-23001	Pg. 26
----------------------------------	------------------------------	--------------------	---------------	--	-----------

<b>DIMENSION BID</b>	DIMENSION BID COILED TUBING SERVICES		
	ANGSI A-12S	WELL DIAGNOSIS WITH CAMERA RUN	

Depth, ft	RIH weight, lbf	Static weight, lbf	Pick up weight, lbf

18. Continue RIH slowly at 5 ft/min with pumping rate 0.3BPM until tag PXN Plug at **3,049 m / 10,004 ft MDDF**. Pick up CT to **3,039 m / 9,967 ft MDDF** (10m above PXN Plug) and retag again on PXN Plug not exceeding 1,000 lbf to verify the depth. Flag the CT on surface and record the running hours from surface until CT reach top PXN Plug in daily report. Record the following and include in daily report.

Flag Number	Colour
Flag#1	

Depth	Running Hour ( hr:min)
0 – 3,049 m MDDF	

- 18.1. If there is no indicator of hard tag at top of PXN Plug depth at **3,049 m MDDF**, pick up CT 10m above top of tubing cut and retag again for several times until indicator of hard tag is observed. **(DO NOT SLACK OFF MORE THAN 1,000 lbf)**.

- 18.2. Once confirm CT tag Top of PXN Plug at **3,049 m MDDF**, **reset Mechanical & Electrical Depth Counter**.

19. Proceed hole cleaning by pumping gel for **65 bbls** and follow by bottoms up with TIW **131 bbls** (1.5x tubing volume) as per in table **step 14.1**. During CBU, monitor and **collect the sample** at sampling point of flowback line and hand it over to EV Engineer to check the clarity of the sample.
20. Proceed pick up CT to depth **3,044 m / 9,984 ft MDDF (5m above top of PXN Plug)** and flag CT on surface. This will be **Flag#2 (2<sup>nd</sup> logging depth)**. Record the following and include in daily report.

Flag Number	Colour
Flag#2	

21. Pickup CT to **2,680 m / 8,793 ft MDDF** while maintaining pumping parameter and flag CT at surface. This will be **Flag#3 (1<sup>st</sup> logging depth)**. Record the following and include in daily report.

Flag Number	Colour
Flag#3	

22. POOH CT to surface while pumping TIW at 0.3bpm. Ensure continuous return on surface is observe.
- 22.1. Maximum CT speed while POOH is 50ft/min.
- 22.2. Slow down CT speed to 10ft/min 50ft before and after passing through completion accessories.
23. Once CT on surface, close well and bleed off pressure in CT and stack up.

Prepared By: M. Ameerul Zaeem	Reviewed By: Kung Yee Han	Date: 16/3/2023	Rev. Rev.2	Controlled Document DB-CT-MAZ-23001	Pg. 27
----------------------------------	------------------------------	--------------------	---------------	--	-----------

<b>DIMENSION BID</b>	DIMENSION BID COILED TUBING SERVICES		
	ANGSI A-12S	WELL DIAGNOSIS WITH CAMERA RUN	

**COILED TUBING OPERATION – RUN#2 RUN EV CAMERA UNTIL TOP OF PXN PLUG AT 3,049 M MDDF / 10,000 FT MDDF**

All depths specified below are in m-MDDF (Drill floor to THF is 16.9-m as per well schematic)

24. Prepare 100 bbls of Treated Injection Water, TIW as per recipe below:

Treated Injection Water (TIW)				100	BBL	Description
Seq.	Product	Concentration		Volume		
1	Injection Water	992	gptg	4,166	gal	Base Fluid
2	ACM H2S Clear 200	2	gptg	8	gal	CO2 & H2S Corrosion Inhibitor
3	ACM BACT 200	2	gptg	8	gal	Micro Biocide Control
4	ACM OXYFREE 100	2	gptg	8	gal	Oxygen Scavenger
5	MESB NE-Surf 200	2	gptg	8	gal	Non-Emulsifier Surfactant
<b>Mixing Instruction:</b>						
<ol style="list-style-type: none"> <li>1. Prepare injection water in the mixing tank.</li> <li>2. Add ACM H2S Clear 200 &amp; ACM OXYFREE 100 into the tank and circulate the mixture.</li> <li>3. Add ACM BACT 200 &amp; NE-Surf 200 into the tank and circulate the mixture until homogenous.</li> </ol>						

**Note:** The above recipe is for 100bbls of TIW. Please prepare another batch of TIW once needed.

25. Make up tool as per BHA#2: EV Camera in Appendix I.

**Note:** Before assembling and running any bottom-hole assembly, ensure surface filter is placed in the fluid flow path to filter any debris that may have become suspended in the fluid.

26. Fill up BHA checklist (Appendix I – BHA CHECKLIST), to be review by Well Service Supervisor (WSS) and obtain approval from town prior RIH.

26.1. Supervisor needs to measure the length, OD and ID of the BHA and ensure they are serviced in good condition. Upon approval from Engineer in charge, Supervisor may start to run in hole.

**Note:** Ensure EV Engineer in charge has reviewed and provided signature of approval as well to confirm we have prepared according to the program.

26.2. Perform a surface function test with tools before programming them for the job. Program the tools for a delay of 5 minutes, LED will light up indicate that the camera is online. Once the function test is confirmed proceed to program the camera for the logging run as calculated based on previous run #1. This will be done by EV Engineer.

**Note:** There is a total 300 recording minutes available (5 Hours), this cannot be exceeded. Please use the programme simulator to check there is enough memory available for the entire program as stated in table **step 29**. To be confirmed with EV Engineer.

Prepared By: M. Ameerul Zaeem	Reviewed By: Kung Yee Han	Date: 16/3/2023	Rev. Rev.2	Controlled Document DB-CT-MAZ-23001	Pg. 28
----------------------------------	------------------------------	--------------------	---------------	--	-----------

<b>DIMENSION BID</b>	DIMENSION BID COILED TUBING SERVICES		
	ANGSI A-12S	WELL DIAGNOSIS WITH CAMERA RUN	

Flow rates (bpm)	Pressure (psi)	Remark
0.3		
0.5		
0.6		
0.7		
0.8		
0.9		
1.0		
1.1		
1.2		
1.3		
1.4		
1.5		

**Note:** Record maximum pump rate allowable without exceeding 5,000 psi. Max flowrate is 2 bpm. Follow instruction from EV Engineer onsite.

27. Repeat step 6 till 12 in Run#1 prior making up EV Camera and open the well. Ensure pressure inside riser is higher than WHP before open up the well to avoid spraying the lens which can cause bad image quality.
28. Start RIH with EV Camera with following sequence as per table in **step 29**. Refer to CT Tubing Force simulation (Orpheus modelling), refer Appendix III.

**Note:** Prior to RIH, CT supervisor must conduct a proper discussion with EV Engineer on the procedures & time planning to avoid any hiccup during Day-Night shift crew change. RIH must be done as per DB and EV's agreed procedure. EV Engineer must be present throughout the camera run.

- 28.1. Conduct pull test as per for every 300 m (1,000ft), use CT Fatigue graph as reference in Appendix. Ensure the CT Fatigue graph is available at location before RIH. Record RIH, Hanging and POOH weight in daily report.
- 28.2. Maximum CT speed RIH is **30 ft/min**.
- 28.3. Slow down CT speed to **10 ft/min**, 50 ft before and after passing through completion accessories.
- 28.4. Slow down CT speed to 10 ft/min, 50 ft before and after passing through previous slickline HUD at 2,747 m MDDF / 9,012 ft MDDF (November 2022).
- 28.5. Slow down CT as low as possible at area of interest as stated in **step 29**.
- 28.6. Closely observe weight indicator in control cabin while RIH.
- 28.7. Observe return all the times.
- 28.8. Regularly inform WSS on job status at all times.
- 28.9. EV Engineer to be inside CT Control Cabin and give specific direction to CT Operator during Memory Camera Run to ensure good quality and optimum camera result.
- 28.10. Do not exceed operating safety limits **5,000 psi**.
- 28.11. If the well condition differs from original job design, contact appropriate personnel in charge before proceeding.
- 28.12. At all time, while RIH, the injector torque control shall be set at the minimum pressure required to move the CT at specified speed.

Prepared By: M. Ameerul Zaeem	Reviewed By: Kung Yee Han	Date: 16/3/2023	Rev. Rev.2	Controlled Document DB-CT-MAZ-23001	Pg. 29
----------------------------------	------------------------------	--------------------	---------------	--	-----------

<b>DIMENSION BID</b>	<b>DIMENSION BID COILED TUBING SERVICES</b>		
	ANGSI A-12S	WELL DIAGNOSIS WITH CAMERA RUN	

29. Refer table below when start RIH with idle rate at 0.3 bpm:

#	Programme Step	Well Status	Pass/Station	Camera	Comment	From (ft)	To (ft)	Interval (ft)	Speed (ft/min)	Time (min)	
1	IDLE	Shut in	Station	Delay	Camera Delay	0	0	0	-	5	
2	LOG	Shut in	Station	DV	Surface function test camera (LED lights On)	0	0	0	-	5	
3	IDLE	Shut in	Station	Delay	Camera Delay: Rig up, Pressure test, Open up well slowly. Follow instruction EV Engineer On Board to check tools at 50m (165 ft)	0	0	0	-	120	
4	RIH	Shut in	Down Pass	Delay	RIH until 2,680-m MDDF (8,793 ft MDDF) with idle pumping rate to avoid grease / contaminant stick to the lens. CAMERA OFF	0	8793	8793	32	268	
5	IDLE	Shut in	Station	DV	Stop Pumping. CAMERA ON	8793	8793	0	0	5	
6	LOG	Shut in	Down Pass	DV	Pass 1: Verify packer no. 1 condition and inspect possible leak at 2692.57-m MDDF (8,834 ft MDDF)	8793	8892	99	7	15	
7	LOG	Shut in	Up Pass	DV	Up Pass	8892	8793	99	7	15	
8	LOG	Shut in	Down Pass	DV	Pass 2: Verify packer no. 1 condition and inspect possible leak at 2692.57-m MDDF (8,834 ft MDDF)	8793	8892	99	7	15	
9	LOG	Shut in	Up Pass	DV	Up Pass	8892	8793	99	7	15	
10	LOG	Shut in	Down Pass	DV	Start inspecting the area from 2,732-m MDD (8,963 ft MDDF) until HUD at 3,044-m MDDF (9,987 ft MDDF)	8793	9987	1194	23	52	
11	LOG	Shut in	Down Pass	DV	Pass 1: RIH to HUD (slow as possible)	9987	10004	17	7	3	
12	LOG	Shut in	Up Pass	DV	Up Pass	10004	9987	17	7	3	
13	LOG	Shut in	Down Pass	DV	Pass 2: RIH to HUD (slow as possible)	9987	10004	17	7	3	
14	IDLE	Shut in	Up Pass	DV	Up Pass	10004	9987	17	7	3	
15	LOG	Shut in	Down Pass	DV	Pass 3: RIH to HUD (slow as possible)	9987	10004	17	7	3	
16	LOG	Shut in	Up Pass	DV	Up Pass	10004	9987	17	7	3	
17	LOG	Shut in	Station	DV	Increase pump rate to 0.5 bpm with clear fluid (wait 20 minutes to stabilize)	9987	9987	0	0	20	
18	LOG	Shut in	Down Pass	DV	Conduct <b>step no. 11 to 16</b> for 0.5 bpm log.	9987	10004	17	7	15	
19	LOG	Shut in	Station	DV	Increase pump rate to 1.0 bpm with clear fluid (wait 20 minutes to stabilize)	9987	9987	0	0	20	
20	LOG	Shut in	Down Pass	DV	Conduct <b>step no. 11 to 16</b> for 1.0 bpm log. At the end of the process, <b>slowly tag HUD before POOH</b>	9987	10004	17	7	15	
21	LOG	Shut in	Down Pass	DV	Stop Pumping: POOH slowly for another pass to 2,680-m MDDF (8,793 ft MDDF)	10004	8793	1211	23	53	
22	LOG	Shut in	Up Pass	DV	EXTRA TIME FOR THE CAMERA PROGRAM	0	0	0	0	30	
23	POOH	Shut in	Station	Delay	Camera Off and POOH to surface.	8793	0	8793	32	273	
24	LOG	Shut in	Up Pass	DV	Download camera data. <b>Make sure program is complete and LEDs are off prior dismantling the battery from the camera.</b>	0	0	0	0	60	
										<b>288</b>	
										Rec Time (hrs)	<b>4.8</b>
											<b>1019</b>
										Total Time (hrs)	<b>17.0</b>

**Note:** Refer to EV procedure and EV Engineer to ensure procedures are followed accordingly.

30. Once satisfied that there is enough video, confirm with WSS prior POOH CT to surface.

31. Proceed POOH CT to surface with pump rate 0.3 BPM:

31.1. Maximum CT speed while POOH is 30 ft/min.

31.2. Slow down CT speed to 10 ft/min 50ft before and after passing through completion accessories.

31.3. Do not exceed CT operating limit (refer to Appendix: CT Force simulation)

**Note:** Be sure to allow the camera recording program to finish before disconnecting tools from battery. Failing to do so will cause corruption of the data.

Prepared By: M. Ameerul Zaeem	Reviewed By: Kung Yee Han	Date: 16/3/2023	Rev. Rev.2	Controlled Document DB-CT-MAZ-23001	Pg. 30
----------------------------------	------------------------------	--------------------	---------------	--	-----------

<b>DIMENSION BID</b>	DIMENSION BID COILED TUBING SERVICES		
	ANGSI A-12S	WELL DIAGNOSIS WITH CAMERA RUN	

32. Once CT reaches at surface:
- 32.1. Close master and swab valve.
  - 32.2. Flush pumping line, CT and BHA with TIW.
  - 32.3. Service all BHA and prepare for next run.
  - 32.4. Wait further instruction from town.

Prepared By: M. Ameerul Zaeem	Reviewed By: Kung Yee Han	Date: 16/3/2023	Rev. Rev.2	Controlled Document DB-CT-MAZ-23001	Pg. 31
----------------------------------	------------------------------	--------------------	---------------	--	-----------

<b>DIMENSION BID</b>	DIMENSION BID COILED TUBING SERVICES		
	ANGSI A-12S	WELL DIAGNOSIS WITH CAMERA RUN	

### COILED TUBING OPERATION – RUN#3 ACID STIMULATION ON I-68

All depths specified below are in m-MDDF (Drill floor to THF is 16.9-m as per well schematic)

33. Prior to start acidizing operation, pickle the CT String with 10 bbls of 7.5% HCl, followed by 25 bbls of TFW and neutralization fluid (soda ash) to remove internal rust and ensure no foreign debris inside the CT string. Please refer below 7.5% HCl mixing chemical recipe:

7.5% HCl (Pickling Solution)				420	gals	10	bbls	Description
Seq	Product	Concentration	Volume					
1	Fresh Water	771	gptg	324	gals	7.71	bbls	Base Fluid
2	ACM CORR 400	4	gptg	2	gals	0.05	bbls	Acid Corrosion Inhibitor
3	MESB NE 200	4	gptg	2	gals	0.05	bbls	Non-Emulsifier
4	ACM Surf 210	3	gptg	1	gals	0.02	bbls	Surfactant
5	ACM Iron 300	10	pptg	4	lbs			Iron Sequestering
6	ACM Iron 200	15	gptg	6	gals	0.14	bbls	Iron Control
7	33% HCl	202	gptg	85	gals	2.02	bbls	Raw Acid

**Mixing Instruction:**

1. Fill up tank with fresh water
2. Add additives as per above sequence
3. Agitate until mixture is homogeneous

34. Make up 2-1/8" DownJet Nozzle tool as per **BHA#4: 2-1/8" DownJet Nozzle** in **Appendix I**.
35. Record initial SITHP of short string and long string and annulus pressure of well A-12. Compare pressure parameter record in previous run and inform town if there any changes.

SITHP Short String	SITHP Long String	Annulus Pressure

36. Perform function test of the DownJet Nozzle to determine at which pump rate and pressure of the tool. Record the data in the table below, do not exceed 5,000psi.

Flow rates (bpm)	Pressure (psi)	Remark
0.3		
0.5		
0.6		
0.7		
0.8		
0.9		
1.0		
1.1		
1.2		
1.3		
1.4		

37. Repeat step 6 till 12 in Run#1 prior opening the well.
38. Start RIH CT to **3,049m / 10,004 MDDF (XN-Nipple)** with reference of previous flag while pumping TIW at minimum rate permissible.
- 38.1. Refer to CT Tubing Force simulation (Orpheus modelling), refer Appendix III.

Prepared By: M. Ameerul Zaeem	Reviewed By: Kung Yee Han	Date: 16/3/2023	Rev. Rev.2	Controlled Document DB-CT-MAZ-23001	Pg. 32
----------------------------------	------------------------------	--------------------	---------------	--	-----------

<b>DIMENSION BID</b>	DIMENSION BID COILED TUBING SERVICES		
	ANGSI A-12S	WELL DIAGNOSIS WITH CAMERA RUN	

- 38.2. Conduct pull test as per for every 300m (1,000ft), use CT Fatigue graph as reference. **Ensure the CT Fatigue graph is available at location before RIH. Record RIH, Hanging and POOH weight in treatment report.**
- 38.3. Maximum CT speed RIH is **30-50 ft/min.**
- 38.4. Slow down CT speed to **10 ft/min**, 50 ft before and after passing through completion accessories.
- 38.5. Closely observe weight indicator in control cabin while RIH.
- 38.6. Observe return all the times.
- 38.7. Regularly inform WSS on job status at all times.
- 38.8. Do not exceed operating safety limits **5,000 psi.**
- 38.9. If the well condition differs from original job design, contact appropriate personnel in charge before proceeding.
- 38.10. At all time, while RIH, the injector torque control shall be set at the minimum pressure required to move the CT at specified speed.

39. At **3,039 m / 9,971 ft MDDF (10m above XN Nipple)**, stop CT and conduct pull test of 10m/30ft with pumping rate 0.3BPM and record the pulling weight both static and dynamic (**IMPORTANT**).

Depth, ft	RIH weight, lbf	Static weight, lbf	Pick up weight, lbf

40. Once CT at **3,049 m / 10,004 ft MDDF (XN Nipple)** with reference of previous flag, proceed to mix the following **TFW** solution for Injectivity Test.
41. Prepare 131 bbls (1.5x tubing volume of short string) of **Treated Fresh Water, TFW** as per recipe below:

Treated Fresh Water			4,200	gals	100	bbls	Description
Products	Concentration		Volume				
Fresh Water	959	gptg	4,028	gals	95.90	bbls	Base Fluid
MESB NE-Surf 200	2	gptg	8	gals	0.20	bbls	Non-Emulsifier Surfactant
Ammonium Chloride	417	pptg	1,751	lbs			Clay Stabilizer
ACM Oxyfree 100	2	gptg	8	gals	0.20	bbls	Oxygen Scavenger
ACM H2SClear 200	2	gptg	8	gals	0.20	bbls	CO2 & H2S Corrosion Inhibitor
ACM Bact 200	2	gptg	8	gals	0.20	bbls	Microbiocide

**Mixing Instruction:**

- Fill up tank with fresh water
- Add additives as per above sequence
- Agitate until the mixture is homogenous

**Note:** The above recipe is for 100bbls of TFW. Please prepare another batch of TFW once needed.

42. Prior start pumping activity once completed mixing, record shut in tubing head pressure (SITHP) and casing head pressure (CHP). Include in daily report.

SITHP (psi)	CHP (psi)

43. Bleed off tubing and casing pressure to 0 psi or to minimum as possible.
44. Once complete above step, proceed to fill up the completion volume with 131 bbls (1.5x completion volume) TFW or till steady return is observe on surface without any Nitrogen injection, whichever comes first.

Prepared By: M. Ameerul Zaeem	Reviewed By: Kung Yee Han	Date: 16/3/2023	Rev. Rev.2	Controlled Document DB-CT-MAZ-23001	Pg. 33
----------------------------------	------------------------------	--------------------	---------------	--	-----------

<b>DIMENSION BID</b>	DIMENSION BID COILED TUBING SERVICES		
	ANGSI A-12S	WELL DIAGNOSIS WITH CAMERA RUN	

- 44.1. Do not exceed 5,000 psi CT Circulation pressure or 1,200 psi MASTP during pumping activity. Whichever comes first.
- 44.2. If MASTP exceed 1,200 psi during pumping, stop pump and bleed off pressure prior re-attempt the Injectivity Test.
- 44.3. Consult town in the event the pumping pressure still above 1,200 psi after re-attempt.
- 44.4. Ensure a physical verification is done to reconfirm actual fluid displacement in premix tank vs DAS reading.
- 44.5. While filling up tubing, record THP and CHP as per table below. Include the following table in daily report.

Time (min)	Pump Pressure (psi)	Volume (bbl)	THP SS (psi)	THP LS (psi)	CHP (psi)	Remark

45. Proceed with pump TFW to fill up completion volume (**131 bbls**) prior injectivity test as per below table:

Pumping Schedule to Fill up Completion Volume for Injectivity Test						
Stage	Description	Fluid	Vol (bbl)	Pump Rates (bpm)	Remarks	MASTP (psi)
1	<b>Fill-up Completion Volume</b>	<b>TFW</b>	131 bbls or till return is observed on surface without N2 Injection	0.3-1.4	131 bbls is calculated based on 1.5x tubing volume (Short String)	1,200

46. Once the well is full with TFW, manipulate surface valves as following position prior commence with Injectivity test.

Valve	Position
Reel Manifold	OPEN
Flow Cross Return Valve (Cetco lines)	CLOSE
Wing Valve	CLOSE

47. Begin injectivity test via CT as per table below:

Rate (bpm)	Pumping Pressure (psi)	Time (min)	Volume (bbls)	THP SS (psi)	THP LS (psi)	CHP (psi)
0.30						
0.40						
0.50						
0.60						
0.70						
0.80						
0.90						
1.00						
1.10						
1.20						

<b>DIMENSION BID</b>	DIMENSION BID COILED TUBING SERVICES		
	ANGSI A-12S	WELL DIAGNOSIS WITH CAMERA RUN	

1.30						
1.40						

- 47.1. Ensure PCSB Representative is available and witness the injectivity test.
- 47.2. Sustain each pumping rate for 5 minutes after pressure stabilises.
- 47.3. DO NOT exceed MASTP of 1,200 psi.
- 47.4. Fill up table and include in daily report. Report the results of injectivity test to PCSB and DB EIC.
- 47.5. Minimum injectivity require for this treatment is **0.3 bpm to 0.5 bpm**.

48. After completed injectivity test, manipulate wellhead valves as below:

Valve	Position
Reel Manifold	OPEN
Flow Cross Return Valve (Cetco lines)	OPEN
Wing Valve	CLOSE

49. **Continue pump TFW** with idle rate to ensure well is full with fluid and monitor return while preparing all required treatment fluid.
50. Report the injectivity test result to EIC and WSS.
51. Once obtain approval from DB EIC and PCSB EIC to proceed with the stimulation operation, prepare main treatment fluid as per below recipe:

Pre-Flush Solvent				3360	gals	80	bbls	Description
Seq	Product	Concentration		Volume				
1	Fresh Water	863	gptg	2,900	gals	69,0	bbls	Base Fluid
2	MESB NE-Surf 200	4	gptg	13	gals	0.3	bbls	Non-Emulsifier Surfactant
3	NH4Cl Powder	417	pptg	1,401	lbs			Clay Stabilizer
4	MESB MS 300	100	gptg	336	gals	8.0	bbls	Mutual Solvent

**Mixing Instruction:**

1. Fill up tank with fresh water
2. Add additives as per above sequence
3. Agitate until mixture is homogeneous

15% HCl				3360	gals	80	bbls	Description
Seq	Product	Concentration		Volume				
1	Fresh Water	419	gptg	1,408	gals	33.52	bbls	Base Fluid
2	ACM CORR 400	4	gptg	13	gals	0.32	bbls	Acid Corrosion Inhibitor
3	MESB NE 200	4	gptg	13	gals	0.32	bbls	Non-Emulsifier
4	ACM Surf 210	3	gptg	10	gals	0.24	bbls	Surfactant
5	NH4Cl	417	pptg	1,401	lbs			Clay Stabilizer
6	ACM Iron 300	25	pptg	84	lbs			Iron Sequestering
7	ACM Iron 200	15	gptg	50	gals	1.20	bbls	Iron Control
8	33% HCl	419	gptg	1,408	gals	33.52	bbls	Raw Acid
9	MESB MS 300	100	gptg	336	gals	8.00	bbls	Mutual Solvent

Prepared By: M. Ameerul Zaeem	Reviewed By: Kung Yee Han	Date: 16/3/2023	Rev. Rev.2	Controlled Document DB-CT-MAZ-23001	Pg. 35
----------------------------------	------------------------------	--------------------	---------------	--	-----------

<b>DIMENSION BID</b>	DIMENSION BID COILED TUBING SERVICES		
	ANGSI A-12S	WELL DIAGNOSIS WITH CAMERA RUN	

**Mixing Instruction:**

1. Fill up tank with fresh water
2. Add additives as per above sequence
3. Agitate until mixture is homogeneous

Treated Fresh Water				1050	gals	25	bbls	Description
Seq	Product	Concentration		Volume				
1	Fresh Water	959	gptg	1,007	gals	23.98	bbls	Base Fluid
2	MESB NE Surf 200	2	gptg	2	gals	0.05	bbls	Non-Emulsifier Surfactant
3	NH4Cl	417	pptg	438	lbs			Clay Stabilizer
4	ACM OXYFREE 100	2	pptg	2	gals	0.05	bbls	Oxygen Scavenger
5	ACM H2SClear 200	2	gptg	2	gals	0.05	bbls	CO2 & H2S Corrosion Inhibitor
6	ACM BACT 200	2	gptg	2	gals	0.05	bbls	Microbiocide

**Mixing Instruction:**

1. Fill up tank with fresh water
2. Add additives as per above sequence
3. Agitate until mixture is homogeneous

52. Once all the treatment fluid are prepared, manipulate wellhead valves as below:

Valve	Position
Reel Manifold	OPEN
Flow Cross Return Valve (Cetco lines)	CLOSE
Wing Valve	CLOSE

53. After completed fluid preparation, while CT station at XN Nipple at **3,049m / 10,004 ft MDDF** with reference of previous flag, proceed with pumping main treatment via CT as per below pumping schedule:

53.1. Do not exceed MASTP of 1,200 psi during pumping operation.

53.2. In the event MASTP pressure exceed the limit during pumping operation, stop pump and bleed off the tubing pressure to minimum prior continue with pumping operation.

53.3. Consult town if the pumping pressure still exceeding MASTP after bleed off operation.

Acidizing Pumping Schedule via CT										
Stage	Start Depth (m)	End Depth (m)	Fluid at Reel Manifold	Fluid Entry Volume	Total Fluid Pumped (bbls)	Pump rate (bpm)	Fluid at nozzle	Surface Valve Config.	Remark	MASTP
1	3,049	3,039	Pre-Flush	25	25	0.5	Pre-Flush	Close	Pre-Flush at tip of Nozzle	1,200
2	3,039	3,049	Pre-Flush	49	74	0.5	Pre-Flush	Close	Pre-Flush start exit Nozzle	

Prepared By: M. Ameerul Zaeem	Reviewed By: Kung Yee Han	Date: 16/3/2023	Rev. Rev.2	Controlled Document DB-CT-MAZ-23001	Pg. 36
----------------------------------	------------------------------	--------------------	---------------	--	-----------

<b>DIMENSION BID</b>	<b>DIMENSION BID COILED TUBING SERVICES</b>		
	ANGSI A-12S	WELL DIAGNOSIS WITH CAMERA RUN	

3	3,049	3,039	15% HCl	25	99	0.5	15% HCl	Close	All Pre-Flush exit Nozzle
4	3,039	3,049	15% HCl	49	148	0.5	15% HCl	Close	15% HCl start exit Nozzle
5	3,049	3,039	TFW	25	173	0.5	TFW	Close	All 15% HCl exit Nozzle
6	3,039	610	-		173	0.5	TFW	Open	<b>Station CT at safe depth</b> for Contingency Nitrogen unloading after complete soaking period

54. Record the following parameters while pumping via CT. Include the following table in daily report.

Time (min)	Pump Pressure (psi)	Volume (bbl)	THP SS (psi)	THP LS (psi)	CHP (psi)	Remark

55. Upon completing pumping all treatment fluid according to step 53, pick up CT to safe depth at **610 m / 2,000 ft MDDF & soak the treatment for 4 hours.**

56. After complete **soaking**, manipulate surface valve as per the following position and flowback the well immediately to recover the total fluid pumped approximately **357 bbls** (1.5x total pumped fluid during stimulation).

Valve	Position
Reel Manifold	CLOSE
Flow Cross Return Valve (Cetco lines)	CLOSE
Wing Valve	OPEN

57. Ensure the Single Pump is already rig up at the tapping point of flowback line. Mix Soda Ash to neutralize the flowback fluid as per the following recipe.

Neutralization Fluid			50	BBL	Description
Seq.	Product	Concentration	Volume		
1	Injection Water	976 gptg	49	bbls	Base fluid
2	Soda Ash	500 pptg	1,050	lbs	Neutralization fluid

**Mixing Instruction:**

1. Prepare injection water in the mixing tank.
2. Mix soda ash into tank and agitate until mixture is homogenous.

**Note:** The above recipe is for 50 bbls of Neutralization Fluid. Please prepare another batch if needed.

58. Monitor pH of return fluids and start injecting soda ash once pH reading is below than pH value obtained prior starting treatment. If no acid return observes on surface, continue flow the well without injecting soda ash.

59. Continuously monitor pH of return fluids constantly, every 30 minutes. Stop injecting soda ash when pH reading is equivalent to pH value prior starting treatment.

Prepared By: M. Ameerul Zaeem	Reviewed By: Kung Yee Han	Date: 16/3/2023	Rev. Rev.2	Controlled Document DB-CT-MAZ-23001	Pg. 37
----------------------------------	------------------------------	--------------------	---------------	--	-----------

60. Record the following parameters during monitor well flowback. Include the following table in daily report.

<b>Monitoring Checklist</b>									
Field /Platform/Well : Engineer :									
No.	Date	Time	Choke Size	pH.	% Water Cut	Bbl Counter	FLT	FTHP	Remark
1									
2									
3									
4									
5									
6									
7									
9									
10									
11									
12									
13									
14									
15									
16									
17									
18									
19									
20									

61. Once well is able to flow naturally, POOH to surface.

62. In the event, well is unable to flow naturally after 4 hours period, proceed to unload the well by pumping Nitrogen to lighten the hydrostatic.

62.1. Pick up CT to first circulation point depth at **610 m / 2,000 ft MDDF**, assuming fluid column full of TFW with 8.46 ppg), conduct pull test of at least 10m or more. Record the pulling weight both static and dynamic in the following table.

Depth, ft	RIH weight, lbf	Static weight, lbf	Pick up weight, lbf

62.2. Once CT at **610 m MDDF**, increase the N2 rate at 300 scf/min until 600 scf/min at this depth while monitoring the returns on the surface.

62.2.1. If there is fluid return on surface, continue to pump N2 until only gas return on surface which indicate that the column of fluid above CT BHA is lifted.

62.2.2. Constantly monitor & record the return from the well and THP. Periodically take fluid sample and verify the pH of fluid until achieve baseline pH fluid prior stimulation operation.

62.2.3. If there is no fluid return at surface, proceed to run 300 m / 1,000 ft deeper.

62.2.4. Continue to unload until achieve baseline pH fluid prior acidizing operation.

63. Please note the maximum depth of circulation is at **2,743 m / 9,000 ft MDDF (300m above top perf of I-68)**. This is to avoid N2 losses to formation.

64. Once the well is flowing, stop pumping N2 and monitor the well flow for one hour.

64.1. If the well continues flowing naturally, start to POOH and continue monitor the pH of fluid return until achieve baseline pH prior stimulation operation.

64.2. If the well stops flowing naturally, repeat **step 63.2** by pumping nitrogen again.

<b>DIMENSION BID</b>	DIMENSION BID COILED TUBING SERVICES		
	ANGSI A-12S	WELL DIAGNOSIS WITH CAMERA RUN	

65. POOH CT to surface while pumping TIW at 0.3 bpm. Ensure continuous return on surface is observe.
- 65.1. Maximum CT speed while POOH is 50ft/min.
- 65.2. Slow down CT speed to 10ft/min 50ft before and after passing through completion accessories.
66. Once CT on surface, close well and bleed off pressure in CT and stack up.

Prepared By: M. Ameerul Zaeem	Reviewed By: Kung Yee Han	Date: 16/3/2023	Rev. Rev.2	Controlled Document DB-CT-MAZ-23001	Pg. 39
----------------------------------	------------------------------	--------------------	---------------	--	-----------

<b>DIMENSION BID</b>	DIMENSION BID COILED TUBING SERVICES		
	ANGSI A-12S	WELL DIAGNOSIS WITH CAMERA RUN	

**CT CONTINGENCY #1 – 2.25” IMPACT HAMMER C/W 2.60” PORTED BLINDBOX**

All depths specified below are in m-MDDF (Drill floor to THF is 16.9-m as per well schematic)

67. Prepare 100 bbls of Treated Injection Water, TIW as per recipe below:

Treated Injection Water (TIW)				100	BBL	Description
Seq.	Product	Concentration		Volume		
1	Injection Water	992	gptg	4,166	gal	Base Fluid
2	ACM H2S Clear 200	2	gptg	8	gal	CO2 & H2S Corrosion Inhibitor
3	ACM BACT 200	2	gptg	8	gal	Micro Biocide Control
4	ACM OXYFREE 100	2	gptg	8	gal	Oxygen Scavenger
5	MESB NE-Surf 200	2	gptg	8	gal	Non-Emulsifier Surfactant
<b>Mixing Instruction:</b>						
4. Prepare injection water in the mixing tank.						
5. Add ACM H2S Clear 200 & ACM OXYFREE 100 into the tank and circulate the mixture.						
6. Add ACM BACT 200 & NE-Surf 200 into the tank and circulate the mixture until homogenous.						

**Note:** The above recipe is for 100bbls of TIW. Please prepare another batch of TIW once needed.

68. Make up tool as per BHA#3: 2-1/4” Impact Hammer C/W 2.60” Ported Blindbox in Appendix I.

69. Proceed to perform function test of the Impact Hammer to determine pump rate & pressure parameter for the tools to activate. Record the data in the table below, do not exceed 5,000psi

Flowrate (bpm)	Pressure (psi)	Remarks
0.3		
0.5		
0.8		Based on calculation, the impact force is 18,611 lbs at 120 liter/ min (0.8 bpm)
1.0		

70. Testing Down Acting Hammer

70.1. Connect a ported bullnose to the bottom of the impact tool to ensure free flow.

70.2. Place a wooden block to test the impact hammer.

70.3. Start pumping with the best performance flow rate. Record flow rate and pressure.

70.4. Slowly apply push and let the tool impact until stable frequency is achieved. Record flow rate and pressure.

70.5. Stop circulation & slowly unload the accelerator. Any trapped pressure shall release.

70.6. Tool may start to impact the pressure bleeds off to zero once the tool returned in the neutral position.

71. Repeat step 6 till 12 in Run#1 prior making up BHA and open the well.

72. Start RIH with RIH CT tubing to TOF at 3,049-m MDDF / 10,004-ft MDDF while pumping TIW at minimum rate permissible.

72.1. Refer to CT Tubing Force simulation (Orpheus modelling), refer Appendix III.

Prepared By: M. Ameerul Zaeem	Reviewed By: Kung Yee Han	Date: 16/3/2023	Rev. Rev.2	Controlled Document DB-CT-MAZ-23001	Pg. 40
----------------------------------	------------------------------	--------------------	---------------	--	-----------

<b>DIMENSION BID</b>	<b>DIMENSION BID COILED TUBING SERVICES</b>		
	ANGSI A-12S	WELL DIAGNOSIS WITH CAMERA RUN	

**Note:** Prior to RIH, CT supervisor must conduct a proper discussion with Tool Specialist from Wellpro. RIH must be done as per DB and Wellpro's agreed procedure. Wellpro Tool Specialist must be present throughout the run.

- 72.2. Conduct pull test as per for every 300 m (1,000ft), use CT Fatigue graph as reference in Appendix. **Ensure the CT Fatigue graph is available at location before RIH. Record RIH, Hanging and POOH weight in daily report.**
- 72.3. Maximum CT speed RIH is **30 ft/min**.
- 72.4. Slow down CT speed to **10 ft/min**, 50 ft before and after passing through completion accessories.
- 72.5. Slow down CT speed to 10 ft/min, 50 ft before and after passing through previous slickline HUD at 2,747 m MDDF / 9,012 ft MDDF (November 2022).
- 72.6. Closely observe weight indicator in control cabin while RIH.
- 72.7. Observe return all the times.
- 72.8. Regularly inform WSS on job status at all times.
- 72.9. Wellpro Tool Specialist to be inside CT Control Cabin and give specific direction to CT Operator during Impact Hammer Run.
- 72.10. Do not exceed operating safety limits **5,000 psi**.
- 72.11. If the well condition differs from original job design, contact appropriate personnel in charge before proceeding.
- 72.12. At all time, while RIH, the injector torque control shall be set at the minimum pressure required to move the CT at specified speed.

73. Once CT reach at 3,039-m MDDF / 9,971-ft MDDF (10m above top of fish at 3,049-m MDDF), slow down the speed to 10ft/min and record the weight as per below:

<i>Depth, ft</i>	<i>RIH weight, lbf</i>	<i>Static weight, lbf</i>	<i>Pick up weight, lbf</i>

- 74. Once complete pull test, continue RIH in dry condition and tag the top of fish at 3,049-m MDDF / 10,004-ft MDDF without pumping (Do not slack off more than 1,000 lbf on TOF).
- 75. Once confirmed tag TOF at 3,049 m MDDF, pick up to neutral weight & flag CT on surface (Flag #).

<i>Flag Number</i>	<i>Colour</i>
Flag#1	

- 76. Pick up 10 ft above & start pumping at 0.8 bpm to obtain pumping pressure in downhole parameter.
- 77. RIH slowly until TOF at 3,049-m MDDF / 10,004-ft MDDF & apply set down on TOF to activate the hammer (apply by stages with 500 lbf increment until max set down weight at downhole: 2,000 lbf).
- 78. Continue to hammer for a period of times and monitor depth and flag for any progress made. If CT is moving downwards, pick up 10 m above TOF & record weight parameter.

<i>Depth, ft</i>	<i>RIH weight, lbf</i>	<i>Static weight, lbf</i>	<i>Pick up weight, lbf</i>

- 79. RIH to 3,054-m MDDF (5m deeper than TOF) to verify the tubing / fish is dropped with reference of Flag#1.
- 80. Once verified by Tool Specialist & WSS, proceed POOH to surface.

<b>DIMENSION BID</b>	DIMENSION BID COILED TUBING SERVICES		
	ANGSI A-12S	WELL DIAGNOSIS WITH CAMERA RUN	

**APPENDIX I – BOTTOM HOLE ASSEMBLY SCHEMATIC**

**DIMENSION BID**

**BHA DIAGRAM #1 - 2-1/8" MultiJET Nozzle c/w 2.29" Fluted Centralizer BHA**

<b>Client</b>	Petronas Carigali	<b>Well</b>	A-12S
<b>Field</b>	Angsi Andra	<b>Min Restriction</b>	2.813"
<b>Job Type</b>	Camera Run	<b>BHP</b>	
<b>Job No.</b>		<b>BHT</b>	

BHA DRAWING	DESCRIPTION	CONNECTION		ID	OD	TOOL LENGTH	CUMULATIVE LENGTH
		UPHOLE	DOWNHOLE				
	<b>External Dimple CT</b>	1.5" CT	1.5" AMMT PIN		2.125	0.6	0.6
	<b>MHA</b> Disconnect drop ball 3/4" Shear pressure 5,636 psi  Circulating drop ball 5/8" Shear pressure 2,520 psi Burst Disc 5000 psi	1.5" AMMT BOX	1.5" AMMT PIN		2.125	2.5	3.1
	<b>5 FT Straight Bar</b>	1.5" AMMT BOX	1.5" AMMT PIN		2.125	5.0	8.1
	<b>3 FT Straight Bar</b>	1.5" AMMT BOX	1.5" AMMT PIN		2.125	3.00	11.1
	<b>Crossover</b>	1.5" AMMT BOX	1.0" AMMT PIN		2.125	0.50	11.60
	<b>2.29" Fluted Centralizer</b>	1.0" AMMT BOX	1.0" AMMT PIN		2.290	1.0	12.6
	<b>Crossover</b>	1.0" AMMT BOX	1.5" AMMT PIN		2.125	0.50	13.10
<b>2-1/8" Multijet Nozzle</b>	1.5" AMMT BOX			2.125	0.8	13.9	

<b>BHA LENGTH</b>	<b>13.90</b>
<b>MAXIMUM OD</b>	<b>2.29</b>
<b>MINIMUM ID</b>	

<b>Prepared by:</b>	Muhd Ameerul Zaem
<b>Review by:</b>	
<b>Revision:</b>	
<b>Date:</b>	

**ADDITIONAL INFORMATION:**

<b>DIMENSION BID</b>	<b>DIMENSION BID COILED TUBING SERVICES</b>		
	ANGSI A-12S	WELL DIAGNOSIS WITH CAMERA RUN	

## DIMENSION BID

### BHA DIAGRAM #2- 2-1/4" EV Camera BHA c/w 2.29" Fluted Centralizer

<b>Client</b>	Petronas Carigali	<b>Well</b>	A-12S
<b>Field</b>	Angsi Andra	<b>Min Restriction</b>	2.813"
<b>Job Type</b>	Camera Run	<b>BHP</b>	
<b>Job No.</b>		<b>BHT</b>	

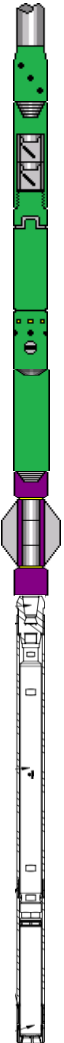
BHA DRAWING	DESCRIPTION	CONNECTION		ID INCH	OD INCH	TOOL LENGTH FT	CUMULATIVE LENGTH FT
		UPHOLE	DOWNHOLE				
	<b>External Dimple CT</b>	1.5" CT	1.5" AMMT PIN		2.125	0.6	0.6
	<b>MHA</b> Disconnect drop ball 3/4" Shear pressure 5,636 psi  Circulating drop ball 5/8" Shear pressure 2,520 psi Burst Disc 5000 psi	1.5" AMMT BOX	1.5" AMMT PIN		2.125	2.5	3.1
	<b>5 FT Straight Bar</b>	1.5" AMMT BOX	1.5" AMMT PIN		2.125	5.0	8.10
	<b>Crossover</b>	1.5" AMMT BOX	1.0" AMMT PIN		2.125	0.50	8.60
	<b>2.29" Fluted Centralizer</b>	1.0" AMMT BOX	1.0" AMMT PIN		2.290	1.0	9.60
	<b>2-1/4" EV Camera (TBC)</b>  Battery: Up to 5 hrs Max rate: 2.0 bpm	1.0" AMMT BOX			2.250	4.02	13.62

<b>BHA LENGTH</b>	13.62
<b>MAXIMUM OD</b>	2.29
<b>MINIMUM ID</b>	

<b>Prepared by:</b>	Muhammad Ameerul Zaeem	<b>ADDITIONAL INFORMATION:</b>
<b>Review by:</b>		
<b>Revision:</b>		
<b>Date:</b>		

<b>DIMENSION BID</b>	<b>DIMENSION BID COILED TUBING SERVICES</b>		
	ANGSI A-12S	WELL DIAGNOSIS WITH CAMERA RUN	

## DIMENSION BID

### BHA DIAGRAM #3 - 2-1/8" DownJET Nozzle BHA

<b>Client</b>	Petronas Carigali	<b>Well</b>	A-12S
<b>Field</b>	Angsi Andra	<b>Min Restriction</b>	2.813"
<b>Job Type</b>	Camera Run	<b>BHP</b>	
<b>Job No.</b>		<b>BHT</b>	

BHA DRAWING	DESCRIPTION	CONNECTION		ID INCH	OD INCH	TOOL LENGTH FT	CUMULATIVE LENGTH FT
		UPHOLE	DOWNHOLE				
	<b>External Dimple CT</b>	1.5" CT	1.5" AMMT PIN		2.125	0.6	0.6
	<b>MHA</b> Disconnect drop ball 3/4" Shear pressure 5,636 psi  Circulating drop ball 5/8" Shear pressure 2,520 psi Burst Disc 5000 psi	1.5" AMMT BOX	1.5" AMMT PIN		2.125	2.5	3.1
	<b>5 FT Straight Bar</b>	1.5" AMMT BOX	1.5" AMMT PIN		2.125	5.0	8.1
	<b>3 FT Straight Bar</b>	1.5" AMMT BOX	1.5" AMMT PIN		2.125	3.00	11.1
	<b>2-1/8" DownJet Nozzle</b>	1.5" AMMT BOX			2.125	0.8	11.9

<b>BHA LENGTH</b>	11.90
<b>MAXIMUM OD</b>	2.125
<b>MINIMUM ID</b>	

<b>Prepared by:</b>	Muhd Ameerul Zaeem
<b>Review by:</b>	
<b>Revision:</b>	
<b>Date:</b>	

<b>ADDITIONAL INFORMATION:</b>

<b>DIMENSION BID</b>	<b>DIMENSION BID COILED TUBING SERVICES</b>		
	ANGSI A-12S	WELL DIAGNOSIS WITH CAMERA RUN	

## DIMENSION BID

### BHA DIAGRAM #4 - 2-1/4" Impact Hammer c/w 2.60" Ported Blindbox BHA

<b>Client</b>	Petronas Carigali	<b>Well</b>	A-12S
<b>Field</b>	Angsi Andra	<b>Min Restriction</b>	2.813"
<b>Job Type</b>	Camera Run	<b>BHP</b>	
<b>Job No.</b>		<b>BHT</b>	

BHA DRAWING	DESCRIPTION	CONNECTION		ID INCH	OD INCH	TOOL LENGTH FT	CUMULATIVE LENGTH FT
		UPHOLE	DOWNHOLE				
	<b>External Dimple CT</b>	1.5" CT	1.5" AMMT PIN		2.125	0.9	0.9
	<b>MHA</b> Disconnect drop ball 3/4" Shear pressure 5,636 psi Circulating drop ball 5/8" Shear pressure 2,520 psi Burst Disc 5000 psi	1.5" AMMT BOX	1.5" AMMT PIN		2.125	2.3	3.2
	<b>Non Rotating Stabiliser</b>	1.5" AMMT BOX	1.5" AMMT PIN		2.500	2.5	5.7
	<b>Dual Acting Impact Accelerator</b>	1.5" AMMT BOX	1.5" AMMT PIN		2.250	6.34	12.0
	<b>Dual Acting Impact Hammer</b>	1.5" AMMT BOX	1.5" AMMT PIN		2.250	3.90	15.9
	<b>2.60" Ported Blindbox</b>	1.5" AMMT BOX			2.600	1.0	16.9

<b>BHA LENGTH</b>	16.89
<b>MAXIMUM OD</b>	2.60
<b>MINIMUM ID</b>	

<b>Prepared by:</b>	Muhd Ameerul Zaeem
<b>Review by:</b>	
<b>Revision:</b>	
<b>Date:</b>	

<b>ADDITIONAL INFORMATION:</b>

<b>DIMENSION BID</b>	DIMENSION BID COILED TUBING SERVICES		
	ANGSI A-12S	WELL DIAGNOSIS WITH CAMERA RUN	

**APPENDIX II – COILED TUBING STACK UP**

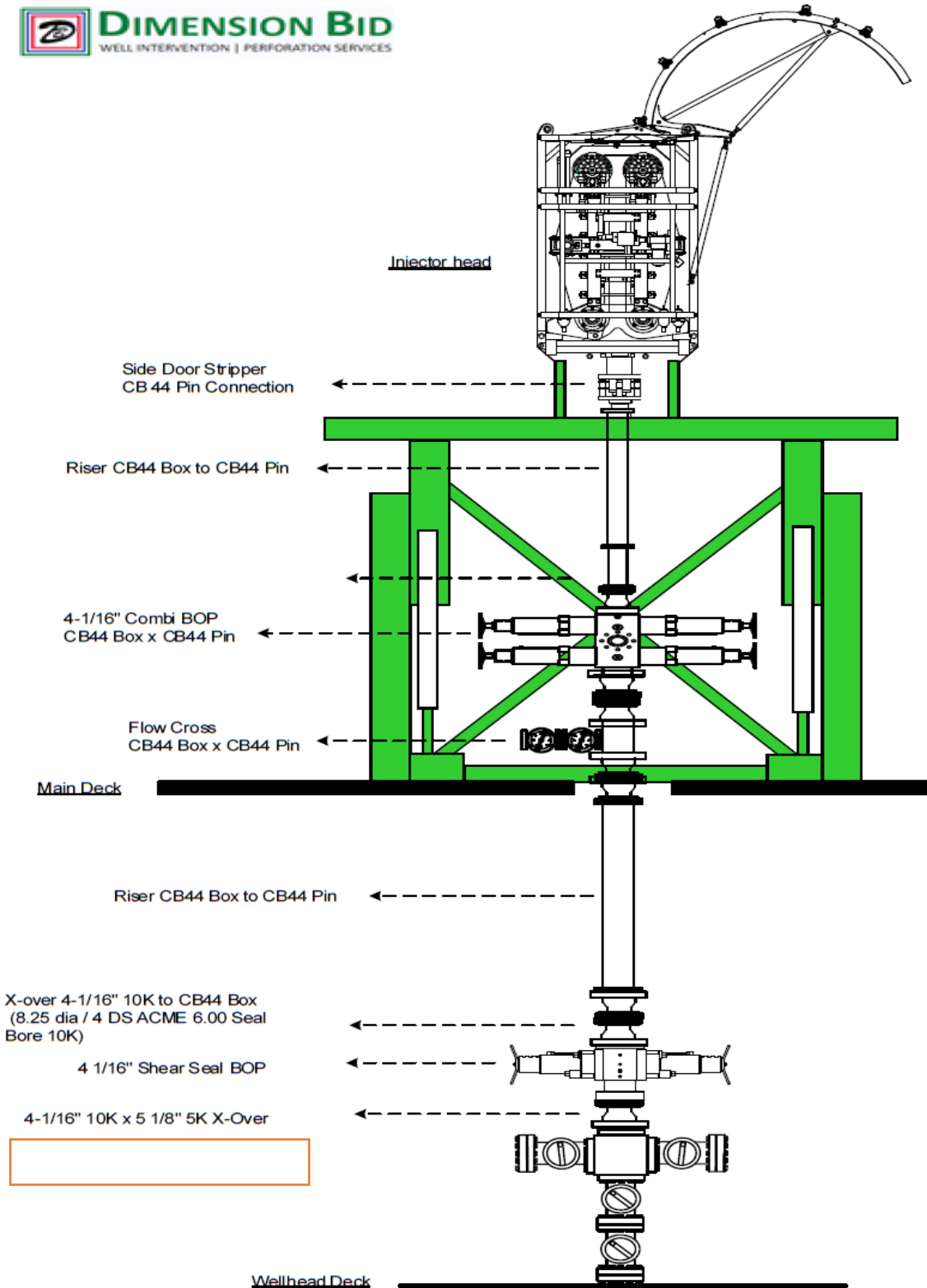

Prepared By: M. Ameerul Zaeem	Reviewed By: Kung Yee Han	Date: 16/3/2023	Rev. Rev.2	Controlled Document DB-CT-MAZ-23001	Pg. 46
----------------------------------	------------------------------	--------------------	---------------	--	-----------

**APPENDIX III – ORPHEUS SIMULATIONS  
LONG STRING**

**TUBING FORCE ANALYSIS**

Graph(1)

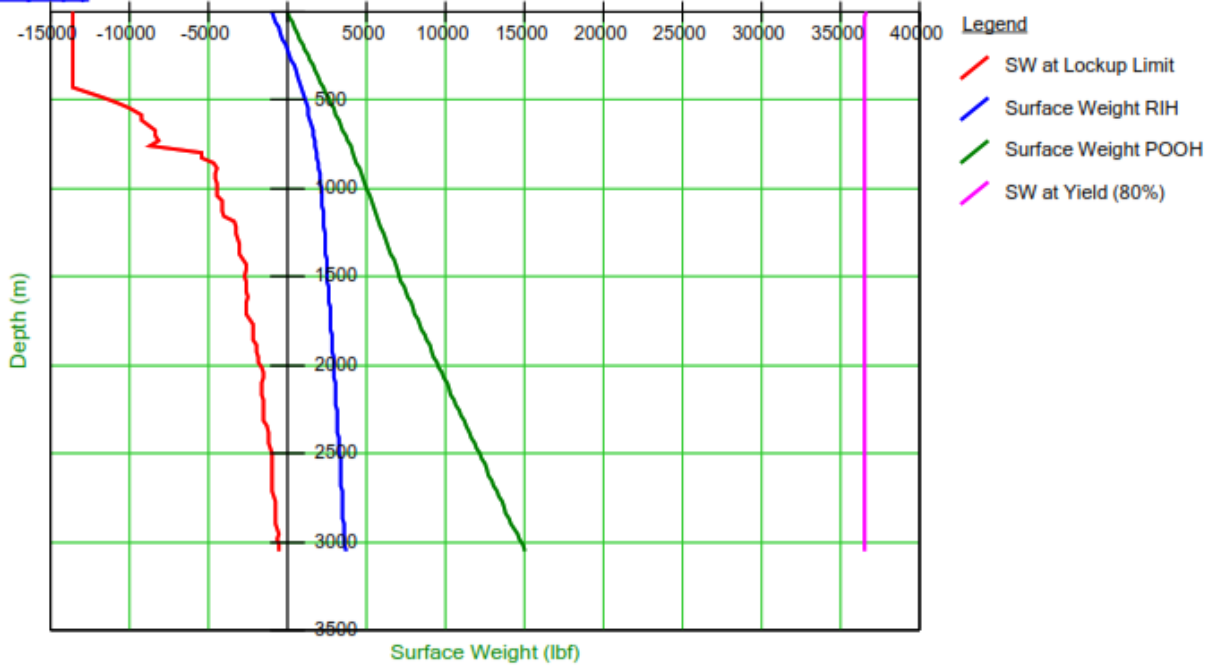

**RIH & POOH WEIGHT**

RIH and POOH

between 0.0 m and 3049.0 m

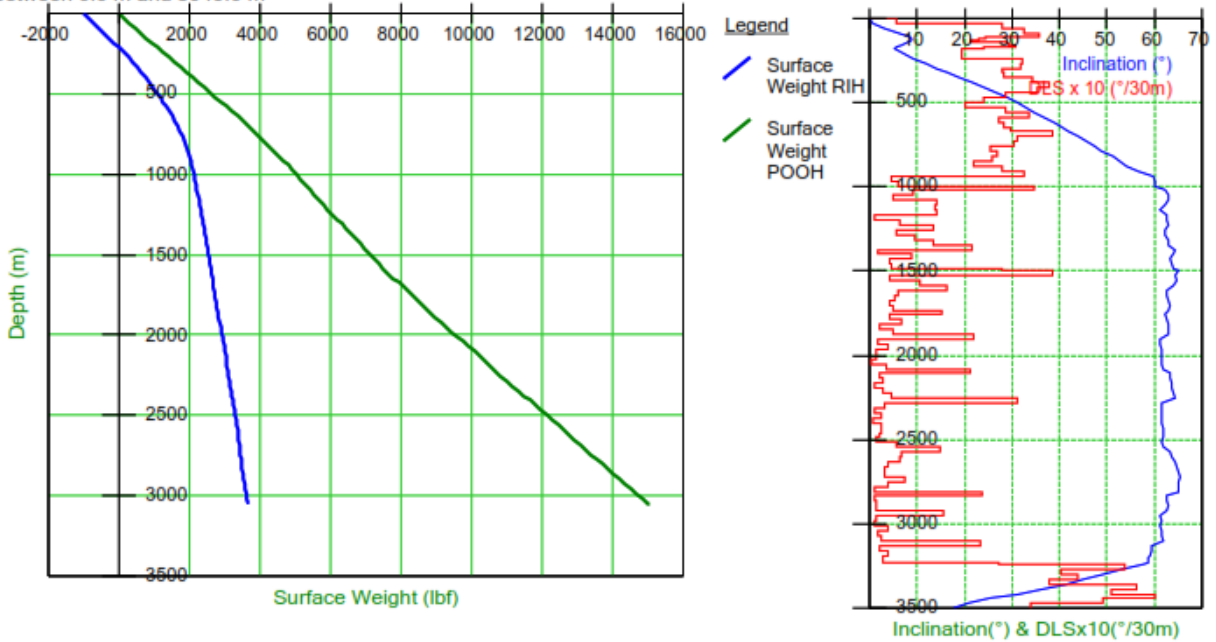

<b>DIMENSION BID</b>	DIMENSION BID COILED TUBING SERVICES		
	ANGSI A-12S	WELL DIAGNOSIS WITH CAMERA RUN	

**MAXIMUM STRING SET DOWN LIMIT**

MD3 ■ The available set-down force at 3049.0 m is -2526 lbf at the end of the string.  
 The weight indicator reading will be -454 lbf on surface.  
 The minimum available set-down force is -2477 lbf at 2956.6 m.

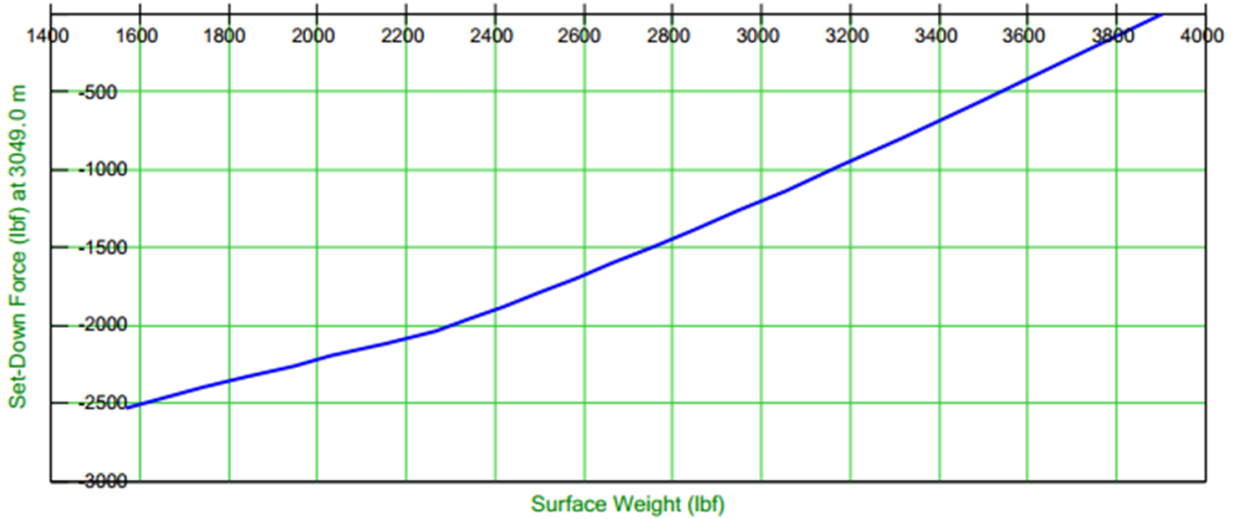

**MAXIMUM STRING PICK UP LIMIT**

MD1 ■ The available pick-up at 3049.0 m based on 80% of yield strength is 13479 lbf.  
 The weight indicator reading will then be 38500 lbf.

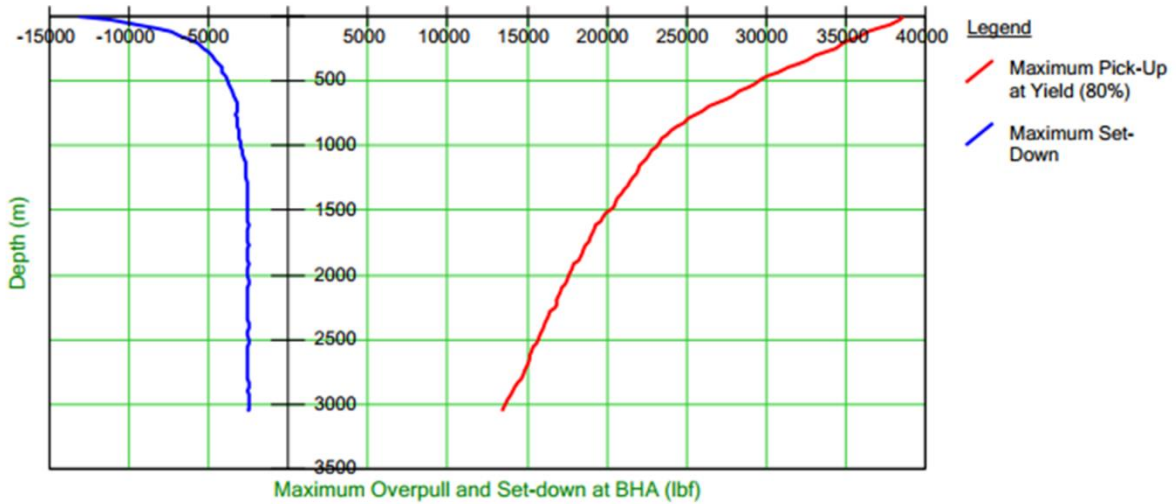

**STRING LIMIT**

CT Limits

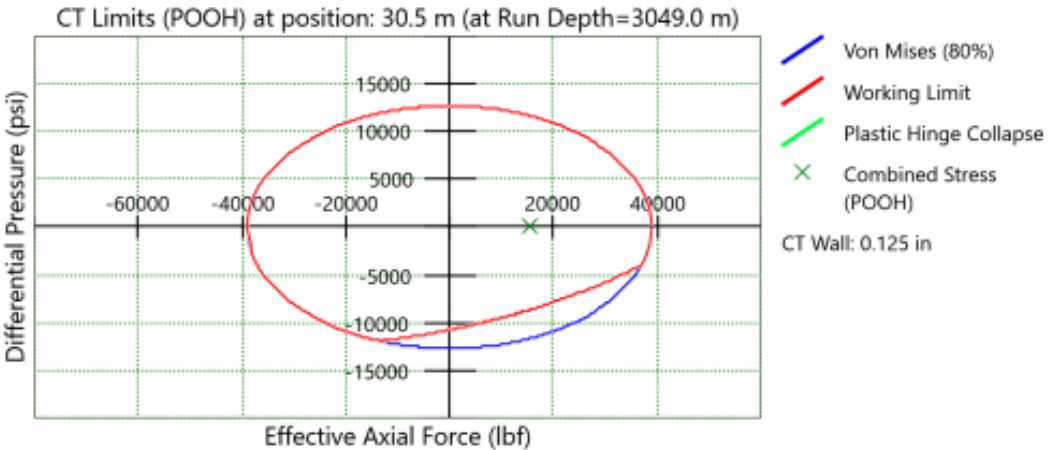
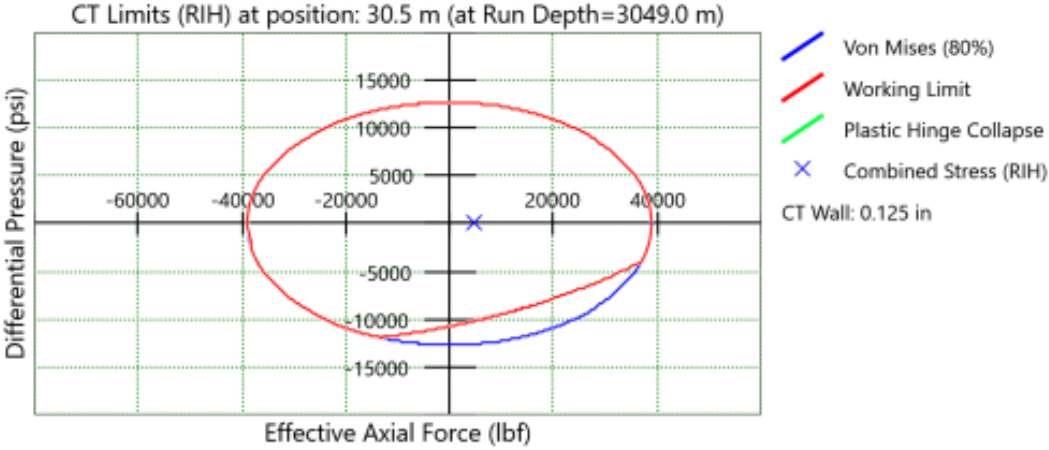

<b>DIMENSION BID</b>	DIMENSION BID COILED TUBING SERVICES		
	ANGSI A-12S	WELL DIAGNOSIS WITH CAMERA RUN	

**Summary of maximum set down weight & maximum pick up weight at 3,049-m MDDF**

Parameter	Maximum set down weight (lbf)	Surface weight reading (lbf)	Maximum pick up weight (lbf)	Surface weight reading (lbf)
0.3 BPM MultiJet Nozzle	2,537	-461	13,442	38,502
1.4 BPM MultiJet Nozzle	2,526	-1,161	12,803	36,786
Nitrified TIW (0.9 BPM & 300 scf) with MultiJet Nozzle	2,427	-900	13,682	37,677
300 scf MultiJet Nozzle	2,155	-1,268	15,439	37,955
0.3 BPM EV Cam	2,526	-454	13,479	38,500
0.5 BPM EV Cam	2,525	-528	13,501	38,492
1.0 BPM EV Cam	2,521	-813	13,401	38,076
0.3 BPM Impact Hammer	2,522	-452	13,486	38,503
0.8 BPM Impact Hammer	2,515	-677	13,499	38,351

<b>DIMENSION BID</b>	DIMENSION BID COILED TUBING SERVICES		
	ANGSI A-12S	WELL DIAGNOSIS WITH CAMERA RUN	

## APPENDIX IV – EMERGENCY PROCEDURE EMERGENCY BOP OPERATIONS

In the event of an emergency arising and the well having to be secured, the following steps should be taken:

1. Stop Coiled Tubing movement, close the Slip and Pipe rams and slack off string weight to ensure slips are holding. If time permits, review all options with the client representative. (Ensure that rams with guides are activated first to avoid damaging the Coiled Tubing).

**Note: The decision to proceed past the above step should normally be made after consultation with the client representative unless there is an immediate and serious danger to personnel and/or equipment and the client representative is not immediately available to be involved in the decision.**

2. Stop pumping.
3. Close the upper Shear Seal rams to cut the Coiled Tubing.
4. Set up to circulate well to kill fluid through the Coiled Tubing remaining in the well.
5. Make arrangements necessary to fish the Coiled Tubing from the BOP.

**Note: When actuating any ram in the BOP system, the corresponding manual lock should be closed behind it to prevent accidental release in the event of total loss of hydraulic power. The force required to close the rams manually against pressure cannot be supplied by turning in the locks. Use of a pipe wrench, cheater bars or snipes will damage the internal workings of the ram actuators. Some form of hydraulic power is required to operate the actuators. This pressure can be supplied via a hand pump or a hydraulic pump from any other piece of equipment on location, including a fluid pumper.**

### Actuating the BOP System Hydraulic Controls

1. Remove locks on control panel
2. Move the control lever to the desired position.
3. Push the BOP activate button supplying pressure to the circuit.
4. Observe the pressure drop in the hydraulic circuit and subsequent pressuring back up to system pressure as ram opens or closes completely.
5. Observe the ram indicator pins to verify the operation of the ram.
6. Close in the manual locks if required. (Flag system to indicate position of rams.)

The connections below the coiled tubing BOP must be all flanged. Should one of these connections start leaking, the following steps should be taken in consultation with the client representative:

1. Call local alert and ensure all personnel are removed from the wellhead area.
2. Notify the client representative of the problem and determine the best method to make the area safe.
3. If the leak is minor, it may be possible to continue to pull the coiled tubing to surface. Assess the scenario and consider all the risks associated then proceed to pull the coiled tubing to surface. Once at surface, close available valves below the leak point.
4. If the leak is more severe, initiate a well kill through the well kill line and continue to pull the coiled tubing to surface.
5. If the leak is catastrophic, run the coiled tubing to HUD; pick up sufficient so that after the coiled tubing is cut at surface by CT BOP shear; the top of the coiled tubing falls below the X-mass Tree. Once the end of the coiled tubing is off bottom, proceed to cut the coiled tubing with the shear RAM then close the available valves below the leak point. A well kill operation can be started through the kill line if requested by the client representative.

Prepared By: M. Ameerul Zaeem	Reviewed By: Kung Yee Han	Date: 16/3/2023	Rev. Rev.2	Controlled Document DB-CT-MAZ-23001	Pg. 51
----------------------------------	------------------------------	--------------------	---------------	--	-----------

<b>DIMENSION BID</b>	DIMENSION BID COILED TUBING SERVICES		
	ANGSI A-12S	WELL DIAGNOSIS WITH CAMERA RUN	

## LEAK IN COILED TUBING AT SURFACE

In the event of a leak in the Coiled Tubing occurring at surface, the following steps should be taken:

1. Call local alert and ensure all personnel are removed from the operational area. In particular make sure all personnel remain clear of the area between the Injector Head and the Coiled Tubing reel.
2. If the leak is small or a pinhole leak, POOH and position the leak on the lower part of the Coiled Tubing reel as soon as possible. Be careful when area of leak is bent onto the reel as failure may occur. Make arrangements to have a water hose present to wash away any fluid from the reel which may be hazardous. Make arrangements to start pumping water through the Coiled Tubing reel. Depressurize reel as much as conditions allow without exceeding collapse limitations of Coiled Tubing.
3. Notify client representative of problem and determine best method to make area safe. If leak is minor and water can be displaced to leak, continue to POOH and change reel.
4. If leak is considered to be too serious to displace to water and POOH, or serious and uncontrolled leakage of hydrocarbon or hazardous materials prevents this, (i.e. check valves not holding, lost BHA, parted Coiled Tubing) set the Coiled Tubing slips and pipe rams. Activate the upper Shear Seal rams on either the triple or quad BOP and manually lock in place.
5. Depressurize the Coiled Tubing reel and flush through the reel. If hydrocarbons are present in the reel, displace the reel with water and empty the contents to specified safe disposal area.

## LEAK IN COILED TUBING BELOW SURFACE

If a leak occurs in the Coiled Tubing below the Stuffing Box during down hole operations (usually indicated by a drop in pump pressure or loss of string weight), suspend Coiled Tubing operations and alert the client representative.

**Note:**

**If indications are that the BHA has been lost in hole then revert to section 0.**

1. Once the client representative has been alerted, clear all personnel from the immediate area of the Coiled Tubing around the Injector Head and between the Injector Head and the Coiled Tubing reel.
2. Displace the Coiled Tubing to water and commence to POOH at not more than 20 ft per minute (5 meters/min). Ensure at all times that all personnel are clear of the immediate area as the possibility exists to pull the Coiled Tubing out of the Stuffing Box. Continue pumping water at a slow rate through the Coiled Tubing.
3. When the leak in the Coiled Tubing appears above the Stuffing Box, stop the injector and hold the leaking section of Coiled Tubing between the chains and the Stuffing Box.
4. Inspect leak. If leak is minor continue to POOH.
5. If leak is major, or Coiled Tubing is actually severed or well bore fluids are escaping through the Coiled Tubing, continue as per Section 09.2.

Prepared By: M. Ameerul Zaeem	Reviewed By: Kung Yee Han	Date: 16/3/2023	Rev. Rev.2	Controlled Document DB-CT-MAZ-23001	Pg. 52
----------------------------------	------------------------------	--------------------	---------------	--	-----------

<b>DIMENSION BID</b>	DIMENSION BID COILED TUBING SERVICES		
	ANGSI A-12S	WELL DIAGNOSIS WITH CAMERA RUN	

## LEAK IN SURFACE PRESSURE CONTROL EQUIPMENT

### Stuffing Box

1. **Stop** Coiled Tubing movement and close both sets of pipe rams to seal Coiled Tubing annulus. Set manual lock.
2. On semi submersible operations this will be a set of pipe rams and pipe/slip rams.
3. Notify Client representative.
4. Ensure the injector is in neutral and that the brake is engaged.
5. Bleed off pressure above pipe rams
6. Set reel brake. On Semi Submersible jobs the Coiled Tubing should be clamped at the level wind and Coiled Tubing run out of hole until enough slack between the injector and reel is obtained to cope with the heave from the rig, prior to setting reel brake.
7. Bleed off closing pressure on Stuffing Box. Open side doors and apply pressure to retract piston. Replace packer elements and then re-apply pressure to Stuffing Box. Close side doors.

**Note: 3" side door Stuffing Boxes first bleed off closing pressure. Remove hoses from pack and retract piston and connect to open and close on side door. Open door and replace packer element. Close door, bleed off pressure and connect to pack and retract piston.**

8. Slowly open both equalizing valve on pipe rams and check that stripper is holding pressure.
9. If stripper is holding pressure, undo manual locks and open pipe rams or pipe slip rams. When using pipe/slip rams the depth that they were set on the Coiled Tubing must be recorded. Release reel brake and continue operations.

### Surface Leaks Other Than Stuffing Box

1. If leak is minor and a relatively short length of Coiled Tubing is in the hole and the Shear Seal safety head is **below the leak**:
2. Call local alert and notify the client representative.
3. Clear all non-essential personnel away from the area
4. Continue POOH and monitor situation closely
5. Hook up kill line to BOP and pump water slowly down annulus.

### **Note: Avoid collapse situation**

1. Close swab valve and Shear Seal once Coiled Tubing is in riser and repair leak
2. Perform reinstatement test on surface equipment after leak has been repaired
3. If Coiled Tubing is in the well to a considerable depth and leak is considered serious:
4. Call local alert and notify Client representative.
5. Ensure all non-essential personnel are removed from the area.
6. Ensure that Coiled Tubing is sufficiently off bottom so that when the Shear Seal safety head is activated the pipe will drop below the Xmas tree manual master valve. If the Coiled Tubing is stuck down hole, pull to 80% of operating limit before activating Shear Seal BOP, thus allowing the Coiled Tubing to drop below the Xmas tree manual master valve. If the Coiled Tubing is attached to a fish, packer etc pull to 80% of operating limit (if possible) or maximum weight possible before activating Shear Seal BOP, thus allowing the Coiled Tubing to drop below the Xmas tree manual master valve. **If at all possible**, the decision to cut the Coiled Tubing and activate the system will be taken by the Client representative in charge of the operation. This may not always be possible. If the situation is extremely dangerous and requires a fast decision, the Supervisor in charge will take this decision.

Prepared By: M. Ameerul Zaeem	Reviewed By: Kung Yee Han	Date: 16/3/2023	Rev. Rev.2	Controlled Document DB-CT-MAZ-23001	Pg. 53
----------------------------------	------------------------------	--------------------	---------------	--	-----------

<b>DIMENSION BID</b>	DIMENSION BID COILED TUBING SERVICES		
	ANGSI A-12S	WELL DIAGNOSIS WITH CAMERA RUN	

7. Close the Shear Seal rams in the safety head to cut the pipe and allow it to drop. (If the safety head has separate shear and blind rams, close the shear rams to cut the pipe, pull up the Coiled Tubing and close the blind rams).
8. Close the swab valve on the Xmas tree.
9. Close the master valve on the Xmas tree
10. Repair leak and pressure test riser.
11. Plan for fishing operations.

#### Rotating Joint Leak

Eliminate the potential for reel movement by securing the reel with turnbuckles and set reel brake. On Semi-Submersible jobs the Coiled Tubing should be clamped at the level wind and Coiled Tubing run out of hole until enough slack between the injector and reel is obtained to cope with the heave from the rig. Close the reel isolation valve inside the reel and repair or replace the rotating joint as required. Re-test and resume operations.

### COILED TUBING RUNS AWAY INTO WELL

If the inside chain tension system on the Injector Head should fail for any reason, and Coiled Tubing is pulled into the well under its own weight with no control, the procedure should be as per the following:

1. Call a local alert.
2. Attempt to speed the injector up to match the speed of the descending Coiled Tubing.
3. Increase inside chain tension to increase friction on Coiled Tubing.
4. Increase stripper pressure to exert more friction on Coiled Tubing.
5. If these actions fail to make any difference, reduce injector hydraulic pressure to zero.
6. In the event that there is insufficient Coiled Tubing on the reel to reach bottom close Coiled Tubing slips. This action may damage or break the Coiled Tubing. This is the preferred option to using the pipe rams as these will become damaged and a primary well control system will be lost.
7. If the Coiled Tubing is not too far off bottom it may be practical to let it fall to bottom then investigate the causes and repair. This can only be done if there is sufficient Coiled Tubing on the reel to reach bottom.

#### **Note: Coiled Tubing may helix when hitting bottom making it difficult to pull into tail pipe.**

8. Once Coiled Tubing has been controlled, examine Injector Head for damage including chains and POOH.
9. The Coiled Tubing run away may be caused by the injector becoming overloaded with the weight of the Coiled Tubing and fluid in the Coiled Tubing. This situation should not occur if proper pre job planning is done. Correct selection of Injector Head or ensuring Coiled Tubing is full of Nitrogen would prevent this situation from occurring.
10. If a run away situation occurs, reduce the injector hydraulic pressure to zero. This may cause the safety brake in the motors to actuate and counter balance valves to close, stopping the injector.
11. Under certain circumstances if the run away Coiled Tubing is at a speed above the critical speed, the back pressure created by the circulating hydraulic fluid may prevent the injector motor brakes from actuating. If this situation occurs, select the pull mode for the injector and increase system hydraulic pressure until the Coiled Tubing comes to a standstill.

Prepared By: M. Ameerul Zaeem	Reviewed By: Kung Yee Han	Date: 16/3/2023	Rev. Rev.2	Controlled Document DB-CT-MAZ-23001	Pg. 54
----------------------------------	------------------------------	--------------------	---------------	--	-----------

<b>DIMENSION BID</b>	DIMENSION BID COILED TUBING SERVICES		
	ANGSI A-12S	WELL DIAGNOSIS WITH CAMERA RUN	

## COILED TUBING IS PULLED OUT OF STUFFING BOX

This situation is most likely to occur when the Coiled Tubing is being pulled into the riser section. If the BHA is lost including the End Connector there will be no external upset to prevent the Coiled Tubing from passing through the Stuffing Box. If this situation occurs, stop injector before Coiled Tubing passes through the chains and shut in Shear Seal rams on upper BOP's.

If it is thought that the BHA may be lost while down hole, stop the Coiled Tubing at 300ft from surface. Slowly close in the swab valve counting the number of turns. If the Coiled Tubing is still deemed to be across the wellhead, POOH the Coiled Tubing no more than the distance between the top of the wellhead and the top of the Coiled Tubing BOP's. Repeat this step until the swab valve can be fully shut. Once the swab valve is shut, bleed off the pressure in riser.

## COILED TUBING COLLAPSED AT SURFACE

Collapsed Coiled Tubing at surface will be obvious by escape of well bore fluids from the Stuffing Box, as the strippers will no longer seal round the deformed pipe. In addition to this the collapsed pipe will not allow the Injector Head to grip the Coiled Tubing due to its change in shape. Usually collapsed Coiled Tubing will not pull through the bottom brass bushings on the Stuffing Box.

1. If POOH, immediately run Coiled Tubing back in well a sufficient distance to make sure round pipe is in contact with the Stuffing Box.
2. Call alert and notify client representative.
3. Ensure that all non-essential personnel are cleared from the immediate area.
4. Immediately reduce well head pressure by all safe means possible; either flow well through choke at a higher rate or stop annular fluid injection if reverse circulating.
5. Increase Coiled Tubing internal pressure by circulating.
6. Once pressure conditions inside and outside the Coiled Tubing have been optimized, a decision can be taken on how to proceed. If it is not possible to position uncollapsed pipe across the stripper rubbers, i.e. well contents are escaping from stripper rubbers:
7. Call alert and notify client representative.
8. Close pipe rams in an effort to reduce flow of fluid/gas around Coiled Tubing.

**Note: If it is not possible to control the well, the slips will have to be set, and the Coiled Tubing cut using the Shear Seal rams.**

9. Arrange for clamps to be fitted to Coiled Tubing above Injector Head.
10. Remove all non-essential personnel from immediate area
11. Under authority from client representative, kill well.
12. Release pressure from Stuffing Box and remove bushings.
13. Open pipe rams.
14. Attempt to pull Coiled Tubing from the well using the Injector Head.
15. Cut Coiled Tubing at the gooseneck and use the rig or a crane to pull the Coiled Tubing through the injector. Re-clamp the Coiled Tubing above the Injector Head and cut off in thirty foot sections (or as appropriate to the crane or rig)
16. Continue pulling and cutting Coiled Tubing until the Coiled Tubing pulled to surface can be pulled by the Injector Head.

Prepared By: M. Ameerul Zaeem	Reviewed By: Kung Yee Han	Date: 16/3/2023	Rev. Rev.2	Controlled Document DB-CT-MAZ-23001	Pg. 55
----------------------------------	------------------------------	--------------------	---------------	--	-----------

<b>DIMENSION BID</b>	DIMENSION BID COILED TUBING SERVICES		
	ANGSI A-12S	WELL DIAGNOSIS WITH CAMERA RUN	

17. Once Coiled Tubing in good condition (i.e. not collapsed) is at surface, set Coiled Tubing slips and pipe rams and make up roll-on connector to Coiled Tubing on reel.

18. Continue POOH.

If the leak is too serious and cannot be controlled and well fluids are escaping, continue as per Section 9.2.

### COILED TUBING BREAKS AT SURFACE

If Coiled Tubing breaks at surface into two separate sections:

1. Stop the injector and set the slips.
2. Stop pumping operations.
3. Call alert and notify client representative. Ensure all non-essential personnel are cleared from the area and that the area is secure.
4. Secure Coiled Tubing reel.
5. If the reel capacity is insufficient to hold all of the Coiled Tubing remaining in the well due to uneven spooling resulting from the Coiled Tubing failure, it may be necessary to obtain another reel with sufficient capacity to hold the Coiled Tubing remaining in the well.
6. After consulting with client representative, remove damaged section of Coiled Tubing and insert in line roll-on connector and continue to POOH.
7. If this course of action is considered inappropriate or dangerous due to well conditions or condition of Coiled Tubing still in the well, continue as per Section 0.

### BUCKLED TUBING

Should the Coiled Tubing hit an obstruction down hole while RIH with the thrust pressure set too high or running speed too fast, the Coiled Tubing will buckle in a 'Z' shape (plastically hinged).

Coiled Tubing being run inside Coiled Tubing and through small ID BOP's/lubricators will normally buckle between the Stuffing Box and the chains.

Coiled Tubing being run through casing or open hole will normally break below the BOP, usually somewhere around the largest ID.

- The Coiled Tubing will generally buckle several times.
- This type of failure is a little more difficult to detect.

If the Coiled Tubing is being run into casing and a large amount of weight is lost suddenly, there is a very good possibility that the Coiled Tubing is buckled somewhere down hole. Indications of this could be:

- An increase in pump pressure as fluid or gas is now being pushed through an additional restriction created by a hinge.
- A decrease in pump pressure as the Coiled Tubing may have broken removing a restriction such as a BHA.
- A loss of string weight due to the Coiled Tubing breaking and falling off.
- An increase in string weight while pulling out of the hole as the buckled portion of Coiled Tubing creates additional drag or needs to be straightened to get through a restricted ID.

In the event Coiled Tubing buckling is suspected, the Coiled Tubing movement should be stopped and the pump pressure kept within operating limits allowing the situation to be analyzed and determine the correct action to be taken for existing conditions.

**If there is an increase in pump pressure or an increase in string weight:**

Prepared By: M. Ameerul Zaeem	Reviewed By: Kung Yee Han	Date: 16/3/2023	Rev. Rev.2	Controlled Document DB-CT-MAZ-23001	Pg. 56
----------------------------------	------------------------------	--------------------	---------------	--	-----------

<b>DIMENSION BID</b>	<b>DIMENSION BID COILED TUBING SERVICES</b>		
	ANGSI A-12S	WELL DIAGNOSIS WITH CAMERA RUN	

1. Stop the pumps and pick up slowly.
2. POOH slowly (10 to 20 feet per minute) watching the weight indicator carefully.
3. If the Coiled Tubing is buckled close to surface, the buckled Coiled Tubing will pull into the bottom of the Stuffing Box and stop.
4. Close and lock the slip and pipe rams.
5. If the ram indicators show that the rams are not completely closed, there may be more than one piece of Coiled Tubing inside the BOP. In this event, open the rams and try to put undamaged Coiled Tubing across the pipe and slip rams.
6. Make arrangements to kill the well and retrieve the remaining Coiled Tubing from the well.
7. If the buckled Coiled Tubing is down hole and cannot be pulled free, consult the client representative as he may want the Coiled Tubing left at TD prior to being hung off in the slip and Coiled Tubing rams.
8. Arrangements should be made to run Coiled Tubing cutter on wireline to retrieve the Coiled Tubing above stuck point.

**If there is a decrease in pump pressure or a loss of string weight:**

1. It must be assumed that the Coiled Tubing has parted somewhere down hole.
2. Calculate from the remaining string weight approximately how much Coiled Tubing is left in the well.
3. Stop the pumps and POOH slowly.
4. Should the Coiled Tubing come out of the Stuffing Box, the blind rams should also be closed in.

**If the Coiled Tubing is buckled above the Stuffing Box, the following steps should be taken:**

1. Stop the injector as quickly as possible.
2. Close the slip and pipe rams and manually lock them.
3. If the down hole check valves are holding, bleed the pressure in the Coiled Tubing down to zero and monitor for 15 minutes for pressure build up.
4. Consider at this stage whether to kill the well.
5. Use a hacksaw to start the cut until you are sure there is no trapped pressure in the Coiled Tubing.
6. Cut the Coiled Tubing
7. Remove as much of the buckled Coiled Tubing as possible leaving any undamaged Coiled Tubing showing above the Stuffing Box intact so that it may be rejoined later.
8. Bleed the pressure from above the Coiled Tubing rams and undo the connection below the injector.
9. Slowly raise the injector until it is clear of the damaged Coiled Tubing.
10. Cut away any damaged Coiled Tubing, dress the Coiled Tubing and install an inline connector.
11. Run some fresh Coiled Tubing down through the injector until it is just out of the Stuffing Box.
12. Lower the injector until immediately over the pipe sticking out of the BOP.
13. Attach the pipe to the inline connection attached to the pipe sticking up out of BOP.
14. Pump off the inside chain tension and rotate the chains slowly in the OOH direction, while lowering the injector until the connection below the injector can be fastened.
15. Pump up the inside chain tension and pull weight equal to the weight of the Coiled Tubing suspended below the slips plus 2,000 lbf for friction or CERBERUS prediction, whichever is greatest.
16. Equalize the pressure across the Coiled Tubing rams.
17. Unlock the pipe and slip rams.

Prepared By: M. Ameerul Zaeem	Reviewed By: Kung Yee Han	Date: 16/3/2023	Rev. Rev.2	Controlled Document DB-CT-MAZ-23001	Pg. 57
----------------------------------	------------------------------	--------------------	---------------	--	-----------

<b>DIMENSION BID</b>	DIMENSION BID COILED TUBING SERVICES		
	ANGSI A-12S	WELL DIAGNOSIS WITH CAMERA RUN	

18. Open the slip and pipe rams and POOH.

19. If the down hole check valves do not hold then the Coiled Tubing will have to be cut.

## COILED TUBING STUCK IN HOLE PROCEDURES

There are various scenarios by which Coiled Tubing can be deemed as a stuck in hole situation. The following procedures are to be used as generic guidelines prior to the compilation of a signed off chemical cutting program applicable to the current situation.

In the event of being stuck in hole, several factors would have to be taken into consideration, the first of which would be whether the Coiled Tubing is stuck in hole on a platform, or a semi-submersible, as the procedures to be followed may vary greatly between the two options.

Other factors to be considered are:

- Type of well, i.e. flowing oil or gas well, water injector etc.
- The type of BHA being used, i.e. perforating guns, milling assembly, plug etc.
- The type of operation being carried out when the Coiled Tubing became stuck.

In all of the above cases, the Coiled Tubing would be defined as being “stuck” when the pipe cannot be retrieved from the well bore without the pipe exceeding its 80% minimum yield rating, or without exceeding 80% stress of the weak link release rating. The lower of these two factors should always be used when attempting large pulls.

Regardless of the specifics involved, the following procedures should be adopted:

1. Inform the client representative of the situation.
2. Inform the Onshore Engineer.
3. From the information available, and taking into account the well conditions, try to determine the reason for the pipe/BHA being stuck.
4. Attempt to pull free by applying a steady pull to a maximum of 80% of the Coiled Tubing yield. If in doubt as to what this figure is, consult Engineering Department before proceeding.
5. When applying the maximum pull, hold the maximum value for a minimum of 10 minutes and observe the trend (if any) on the weight indicator and chart. Measure the amount of pipe extension that is required when this pull is applied. The figure can be used to determine where the Coiled Tubing is stuck. As a rule of thumb, the depth that the pipe is held at will be the extension of the Coiled Tubing (in feet) when pulled to 80% of yield divided by 0.002. This can be determined using CERBERUS.

The following are options that may be appropriate depending on the particular circumstances:

1. If possible, flow the well, or increase well flow in an effort to remove debris in the well bore that may be holding the Coiled Tubing/BHA. Maintain maximum circulation through the Coiled Tubing at the same time. This is particularly relevant if well cleanout or drilling operations have been performed.
2. Circulate acid across the BHA in an attempt to remove any acid soluble material that may be holding the Coiled Tubing.
3. Pump fluid down the backside of the Coiled Tubing to the formation in an attempt to dislodge debris from around the BHA. Potential Coiled Tubing collapse must be considered if engineering this scenario.
4. Displace Coiled Tubing contents to a lighter fluid (base oil) or gas (Nitrogen) to increase buoyancy and allow greater end force to be applied at BHA.
5. Underbalance the well in the case of differentially stuck Coiled Tubing.
6. Cool the well if the Coiled Tubing is helically stuck in corkscrewed Production Tubing.

Prepared By: M. Ameerul Zaeem	Reviewed By: Kung Yee Han	Date: 16/3/2023	Rev. Rev.2	Controlled Document DB-CT-MAZ-23001	Pg. 58
----------------------------------	------------------------------	--------------------	---------------	--	-----------

<b>DIMENSION BID</b>	DIMENSION BID COILED TUBING SERVICES		
	ANGSI A-12S	WELL DIAGNOSIS WITH CAMERA RUN	

7. Pump down the Coiled Tubing / completion annulus to try and move the source of hold-up.
8. Displace slugs of Nitrogen with water to create a surge effect at the BHA.
9. Pump friction reducer, IM Lube in seawater at 2-3% by volume, down the Coiled Tubing and into the well. Ideally, one well volume will be pumped.
10. After consultation with the client representative and the on call Engineer, activate the emergency disconnect mechanism in the BHA to allow the Coiled Tubing to be released. The release mechanism should only be implemented after all avenues have been explored.
11. When attempting maximum pull, do not work the Coiled Tubing violently across the gooseneck by frequent intervals.
12. The amount of cycles across the gooseneck must be logged, and if in doubt of the Coiled Tubing fatigue condition, the Engineer must be consulted and the cycles entered into the CERBERUS FATIGUE program, to determine the amount of cycles left available.

After consultation with the client representative, kill the well and commence preparations for chemical cutting operations.

Prepared By: M. Ameerul Zaeem	Reviewed By: Kung Yee Han	Date: 16/3/2023	Rev. Rev.2	Controlled Document DB-CT-MAZ-23001	Pg. 59
----------------------------------	------------------------------	--------------------	---------------	--	-----------

**STUCK CT COIL RECOVERY PROCESS**

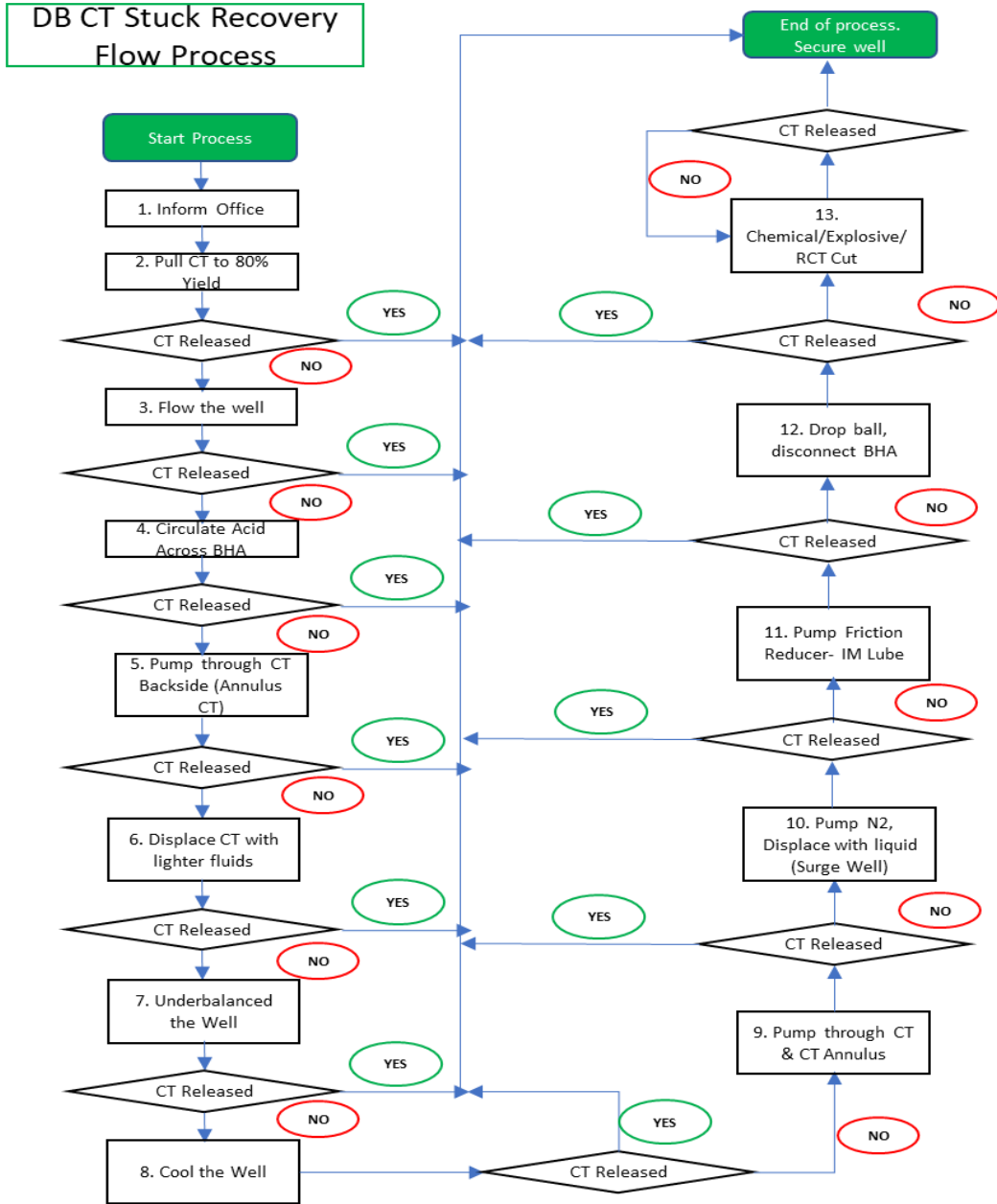

**Precautionary Steps to avoid Stuck while Cleanout in Dual string Completion:**

- 1) To monitor pressure trending all the times during operation and record for any abnormalities. If there is continue pressure increasing trend during cleanout, proceed to pick up coil to the previous pull test depth and perform flow rate test.
- 2) In the event of coil entangle on the Long string, proceed to pick up coil and simulate pumping lost prime scenario to create vibration and tip of coil wobble to release from entanglement.

**APPENDIX V – DECISION TREE**

