

TSA THEORETICAL ASSESSMENT

BY RYAN GIA SMITH

① Slickline Introduction

② Basic Safety

③ Surface Equipment

④ Pressure Control Equipment

⑤ Downhole Equipment

⑥ Safety Sharing

Basic of Wireline – Equipment & Operation

CONTENT

1. SLICKLINE INTRODUCTION

WHAT IS SLICKLINE?

- ▶ Slickline refers to single strand wire which is used to run variety of tools down into the wellbore for several purposes
- ▶ Slickline looks like a long, smooth, unbraided wire, often shiny, silver/chrome in appearance

SLICKLINE WIRE

- ▶ Common wire in Dimension Bid :
 - ▶ 0.108''
 - ▶ 0.125''
 - ▶ 0.140''
- ▶ Length available : 18,000ft, 20,000ft, 25,000ft, 30,000ft.
- ▶ Common used by Dimension Bid is **ZAPP and ZERON**



2. BASIC SAFETY

SAFETY POLICY

7 Safety Policy

- 1) Driving policy
- 2) Drugs and alcohol policy
- 3) Harassment in the workplace policy
- 4) HSSE policy
- 5) PPE policy
- 6) Smoking and vaping policy
- 7) Stop work policy

PERSONAL PROTECTIVE EQUIPMENT(PPE)

- ▶ Wearing the necessary protective gear helps reduce exposure to potential hazards that could result in serious accidents at work
- ▶ The types of PPE -
 1. Types of skin protection(chemical glove, chemical coverall)
 2. Types of respiratory protection
 3. Safety Goggles
 4. Head protection(safety Helmet)
 5. Ear protection(ear-mouth or ear bud)
 6. Safety Shoe
 7. Safety Glove
 8. Coverall
 9. Safety Harness



Hierarchy Of Control

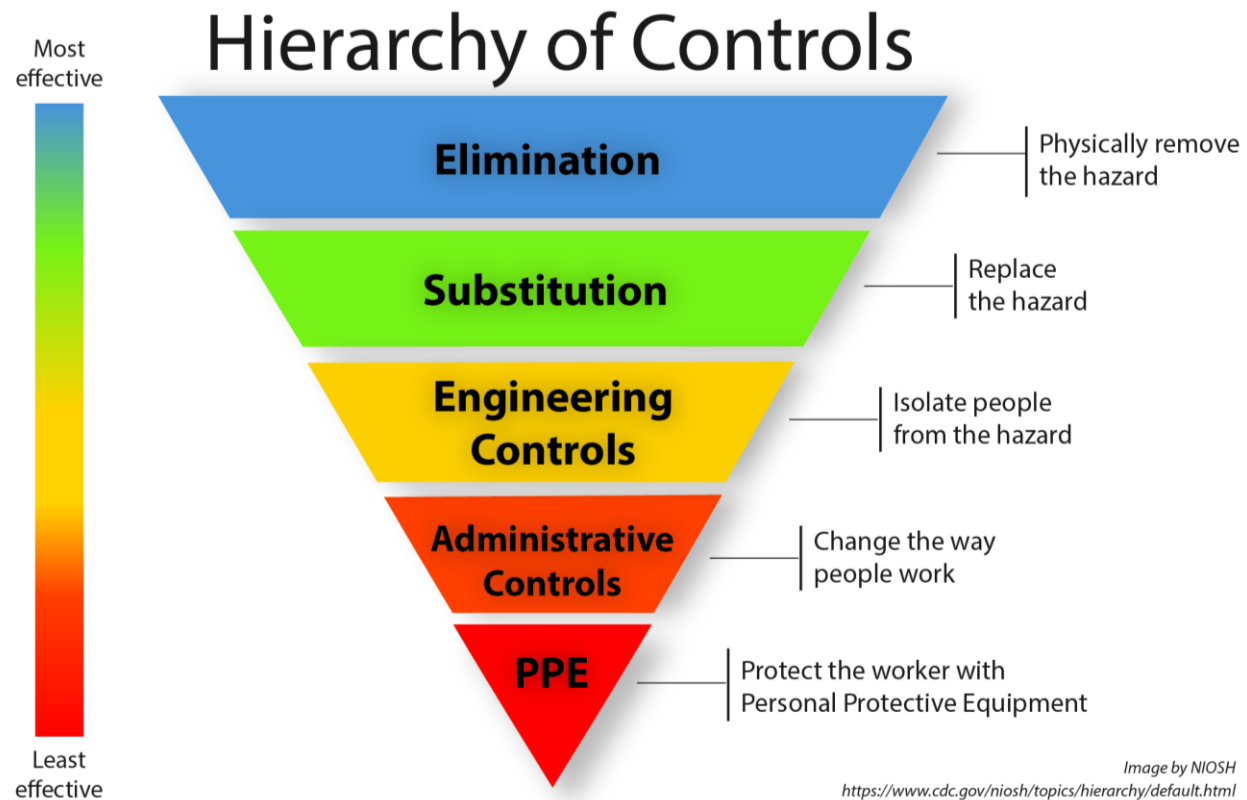

HAZARD HUNT (ACT CARD / UCUA CARD)

Step to fill in Hazard Hunt card:

- a) OBSERVE THE UNSAFE ACT OR CONDITION
- b) INTERVENE/ACTION
- c) FINDING WRITING
- d) AGREED SOLUTION
- e) FOLLOW UP (IF ANY)
- f) CLOSURE

3. SURFACE EQUIPMENT

- ❖ POWER PACK
- ❖ COMPRESSOR
- ❖ REEL SKID UNIT
 - ❖ Angle Drive
- ❖ WEIGHT INDICATOR
- ❖ WIRELINE MAST
 - ❖ LOAD CELL
 - ❖ ODOMETER
 - ❖ HAY PULLEY

HAZARDOUS AREA

Zone 0	Explosive atmosphere is CONTINUOUSLY present
Zone 1	Explosive atmosphere is OFTEN present
Zone 2	Explosive atmosphere is ACCIDENTALLY present

POWER PACK

- ▶ Power pack is a single piece configuration, skid mounted with integral crash frame, constructed in carbon steel with single one lifting.
- ▶ There are 3 types of power pack starter
 - ▶ Hydraulic starter
 - ▶ Spring starter
 - ▶ Pneumatic starter
- ▶ Power pack supply hydraulic power to wireline mast and reel skid unit.
- ▶ Diesel driven
- ▶ 80 horsepower
- ▶ Open loop – SOP, NOV LIGHTLINE, TIS
- ▶ Closed loop –NOV FLYLINE
- ▶ Zone 2 certified equipment



SAFETY SHUTDOWN SYSTEM

SAFETY SHUTDOWN SYSTEM	SET AT
OVERSPEED SHUTDOWN	2200RPM
LOW ENGINE OIL	15 PSI
HIGH COOLANT TEMPERATURE	99 deg Celcius
HIGH EXHAUST TEMPERATURE	200 deg Celcius

Step to start powerpack (SOP)

- ▶ Starting procedure for Zone 2 rated SOP Hydraulic Starter Power Pack :
 1. Set diesel cut off valve to 'Start' position
 2. Pump the power pack until the pressure reaches 2,000 – 3,000 psi
 3. Pull and hold inlet over speed shut down valve
 4. Step on the foot/pedal starter switch
 5. Keep and continue holding the inlet over speed shut down valve (approx. 10 sec.) until oil pressure is built
 6. Release the inlet over speed shut down valve



Diesel cut off valve



Hand pump



Inlet overspeed shut down valve



Foot/pedal starter switch

REEL SKID UNIT (RSU)

- ▶ Also known as wireline unit or winch.
- ▶ To conveys downhole equipment or tools in and out of the well'
- ▶ Single and dual drum
- ▶ Power hydraulic supply from powerpack
- ▶ Maximum working pressure 22,000-25,00 psi

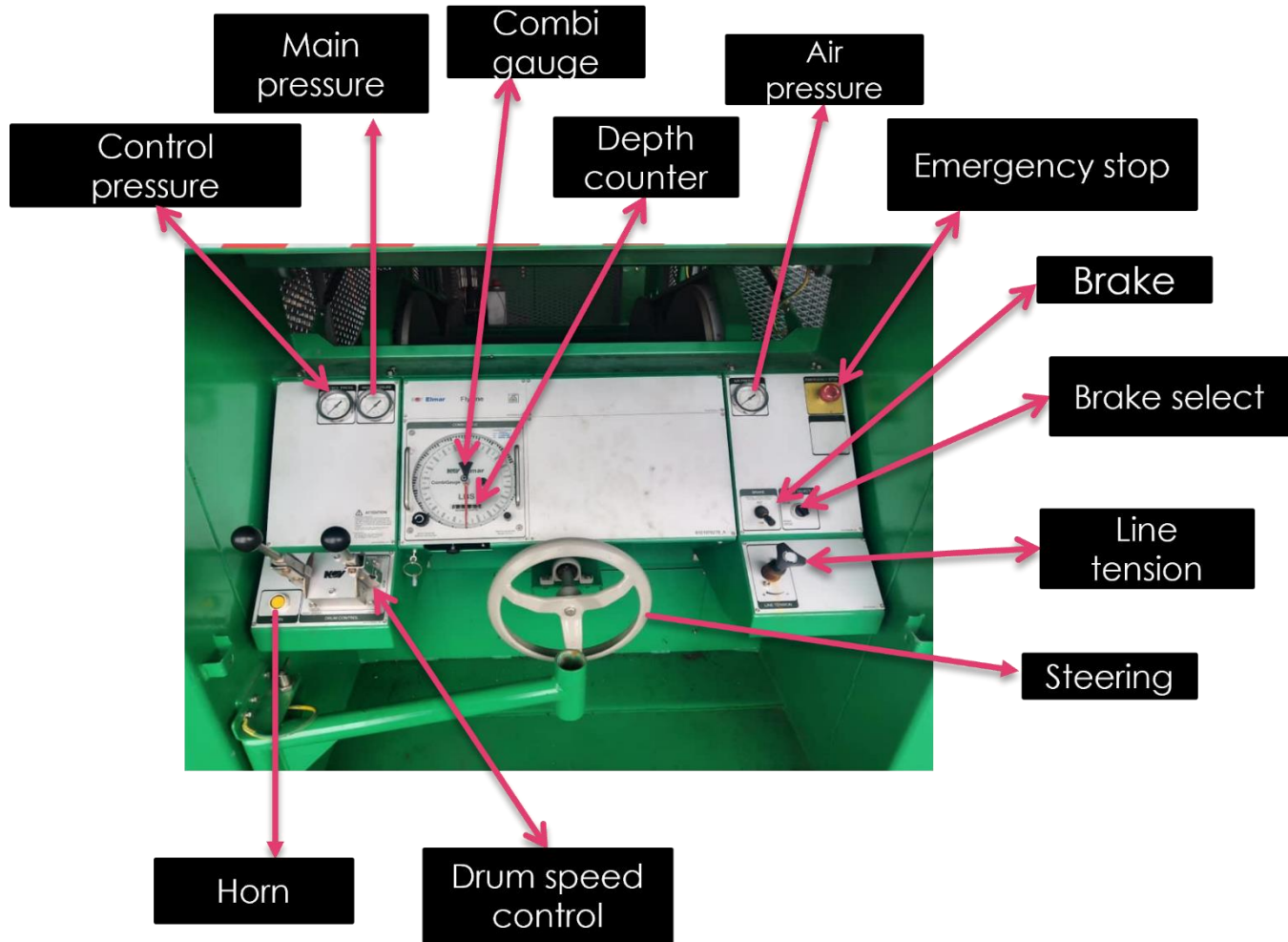

Drum selection valve

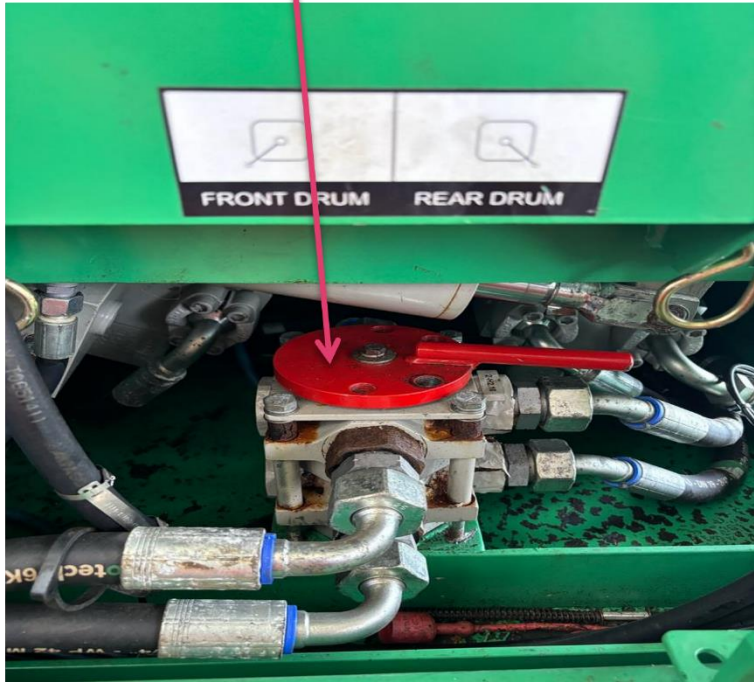

HAY PULLEY

- ▶ To move the wireline horizontally to the wireline winch drum and down from the stuffing box
- ▶ Wire should form 90 degree angle at the pulley
- ▶ Hooked directly onto the eye of weight indicator/load cell



WIRE TESTER

- ▶ To determine the condition
- ▶ Record the result in chart recorder (lbs.)

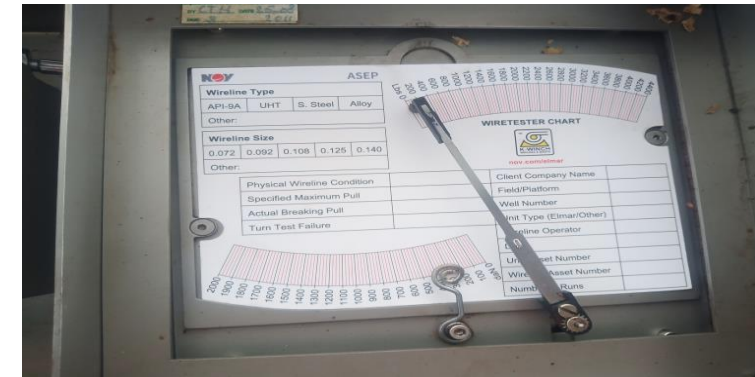
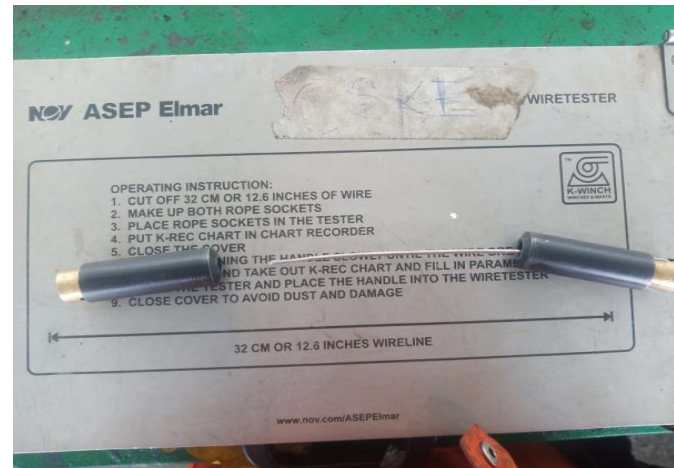

ZAPP WIRE

Diameter (Inch)	Minimum Breaking Load (lbs)	Minimum Torsion	Safe Working Pressure@60 %
0.092"	1920	4	1152
0.108"	2500	3	1500
0.125"	3300	2	1980
0.140"	4050	2	2430

WEIGHT INDICATOR

- ▶ To determine the total weight of tools hung in tubing string



- ▶ Y pump is use to pumped W-15 fluid into the hose to get 7/16 inch or 11mm gap at load cell



- W-15 fluid for hose
- W-8 fluid for gauge



DEPTH INDICATOR

- Known as counter depth
- Use for depth measurement in ft
- Manually set to zero



WIRELINE MAST

- Lifting/hanging for the lubricator during wireline operation (RIG UP)
- Length available usually 30ft, 40ft and 70ft
- Use when gin pole or gantry crane not available on the site



RIGHT ANGLE DRIVE

- **Drive cable** transmit the depth measurement rotary movement to the depth counter
- Converts the measuring wheel rotations to depth units



COUNTER WHEEL

- Also known as **Counter/ Measuring Wheel** or **Measuring Head**
- **Pressure wheels** keep wireline tight in the wheel grooves to ensure maximum contact for precise measurement



AIR COMPRESSOR

- To supply power for SWCP, CP
- Use Spring starter
- Zone 2 certified
- Connection use Chicago types



Safety shutdown system	Set at
Overspeed shutdown	1800 rpm
Low engine oil pressure	20 PSI
High coolant temperature	95 deg Celsius
High exhaust temperature	200 deg Celsius



CHICAGO
CONNECTION

4. PRESSURE CONTROL EQUIPMENT

LIST OF PRESSURE CONTROL EQUIPMENT

- 1) QUICK UNION
- 2) STUFFING BOX
- 3) LUBRICATOR
- 4) QUICK TEST SUB (QTS)
- 5) BLOWN OUT PREVENTER (BOP)
- 6) PUMP IN TEE
- 7) BALL VALVE
- 8) CROSSOVER
- 9) LOW TORQUE VALVE
- 10) CONTROL PANEL
- 11) PRESSURE TEST UNIT (PTU)

QUICK UNION CONNECTION

- ▶ Otis type connection - 45° angle.
- ▶ Bowen type connection - 90° angle
- ▶ Difference between **Otis** and **Bowen** are external holes, internal angle and pin diameter (Otis 3.5") (Bowen 4.375").
- ▶ Usually DB used :
 1. 3" ID
 2. 5-4 ACME = 5" bore ID with TPI (thread per inch)
 3. 5000 psi Working Pressure
 4. Standard/H2S

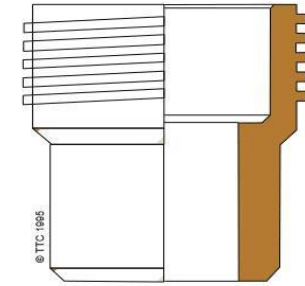
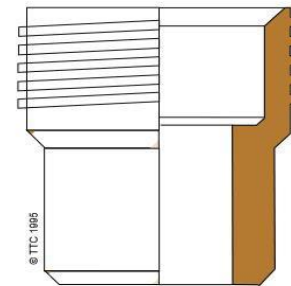
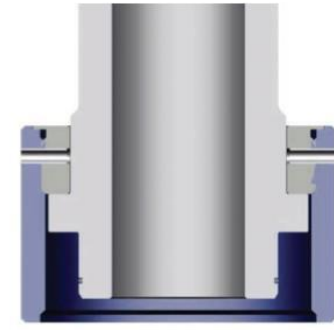
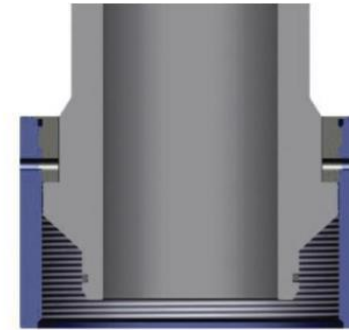

Otis



Bowen

▶ Common connections that can be found in DB are

- ▶ Otis
- ▶ Bowen
- ▶ Elmar

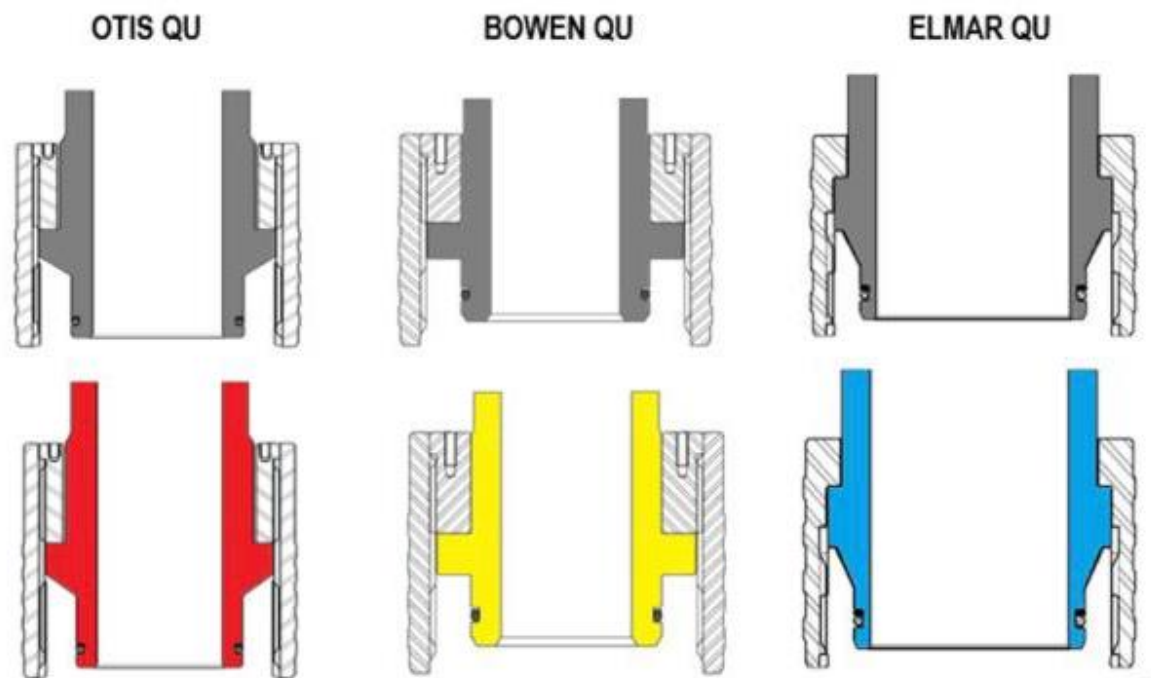

STUFFING BOX

- Primary barrier
- Allow the wire to enter the well under pressure
- Can be operated by hand pump manually
- Sheave diameter available are 16", 18" and 20".
- Guide the wire from bottom hay pulley into top of the lubricator that being rig up
- Brass internal components that can prevent slickline wire from damage



STUFFING BOX COMPONENTS

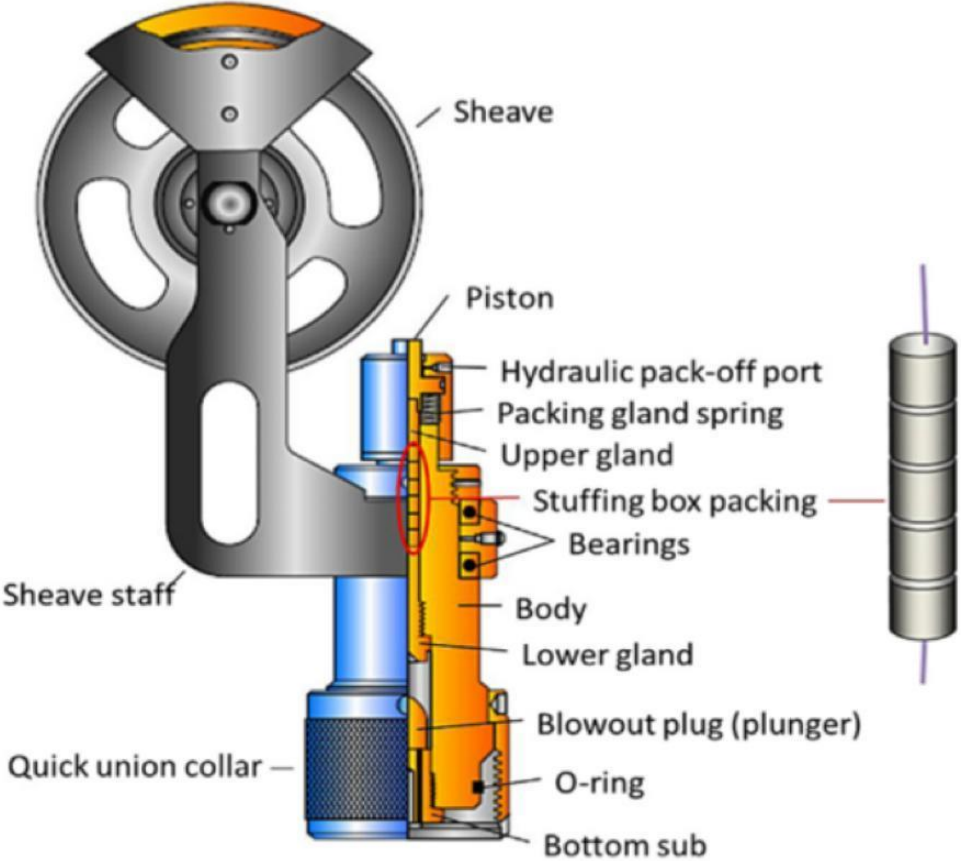

LUBRICATOR

- ▶ To provide space for the tool to be contained in under pressure when opening and closing the wellhead
- ▶ Non-ported and ported
- ▶ Length available 8 ft, 4 ft and 2 ft
- ▶ Length of the lubricator depends on the tool string used

- ▶ There are 3 types of lubricator which is;
 - ▶ Conventional lubricator
 - ▶ Slimline lubricator
 - ▶ Lightweight lubricator

Working pressure(WP) psi	Test pressure(TP) psi
3,000	4,500
5,000	7,500
10,000	15,000
15,000	22,500



Conventional Lubricators (non ported)



Slimline Lubricators (ported)



Lightweight Lubricators (ported)

QUICK TEST SUB (QTS)

- ▶ Inserted above BOP and below lubricator
- ▶ Shorter the time to change tool string during multiple run
- ▶ Connecting hydraulic hand pump to the QTS port and testing the joint O-ring seal from the outside
- ▶ Pressure testing: Body test(hydrotest), Functional test

Injection
port



BLOWN OUT PREVENTER

- ▶ Known as wireline valve
 - ▶ Installed between tree connection and lower lubricator section
 - ▶ Enable to isolate well pressure without cutting the wire
 - ▶ Hold pressure from below
 - ▶ Secondary barrier
-
- ▶ Mechanically and hydraulically to close the rams
 - ▶ Each arm has two fittings for hydraulic
 - ▶ Maximum working pressure 5k psi
 - ▶ Size 3", 4" and 7"



BOP COMPENENT

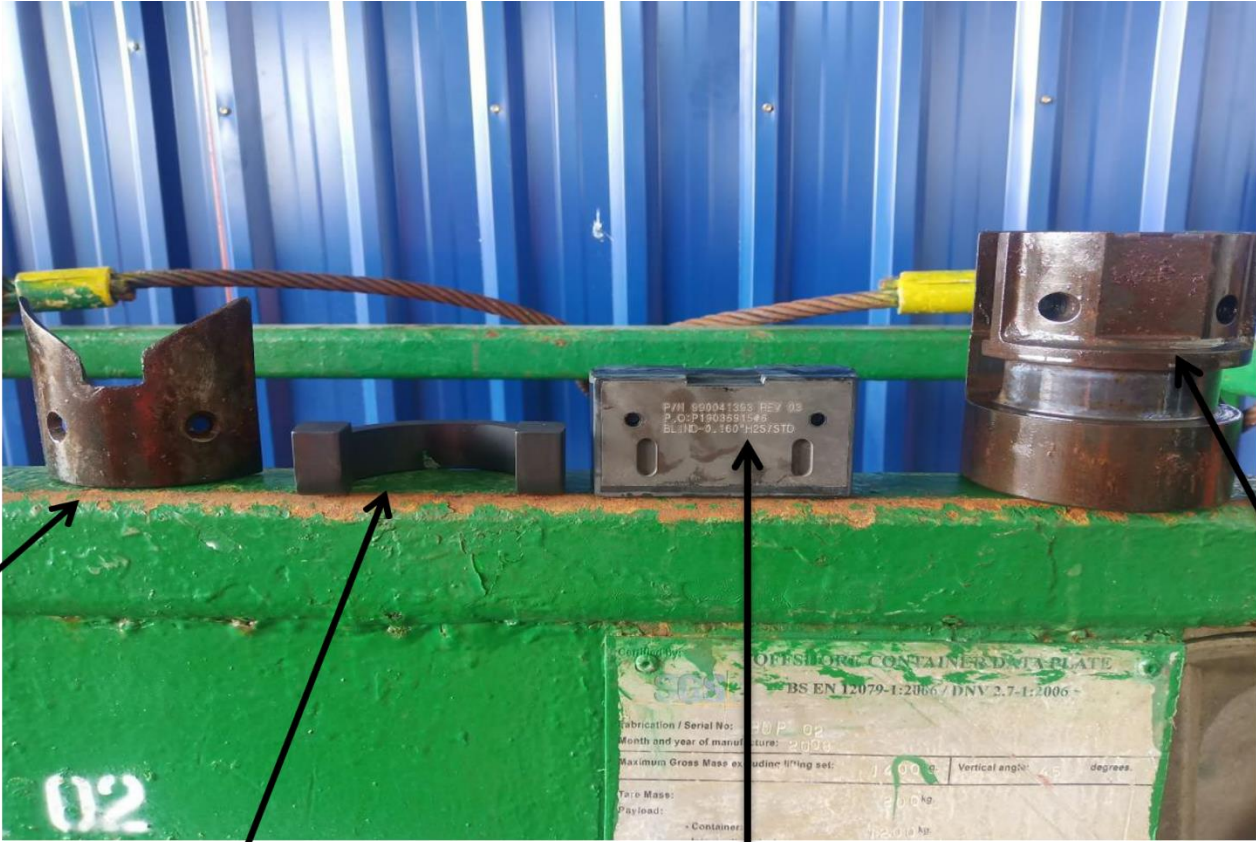

Wire guide

Outer seal

Inner seal

Ram body

PUMP IN TEE

- ▶ Located below BOP and above wellhead
- ▶ Use for chemical injection point



BALL VALVE

- ▶ To hold pressure from above and below
- ▶ Capable to cut wire
- ▶ Located below BOP and above wellhead
- ▶ Can be operate by hydraulic control or manual torque handle



CROSSOVER

- ▶ To provide transition between different size threads and otherwise incompatible unions made by same or different manufacturers
- ▶ Commonly Use QU to QU

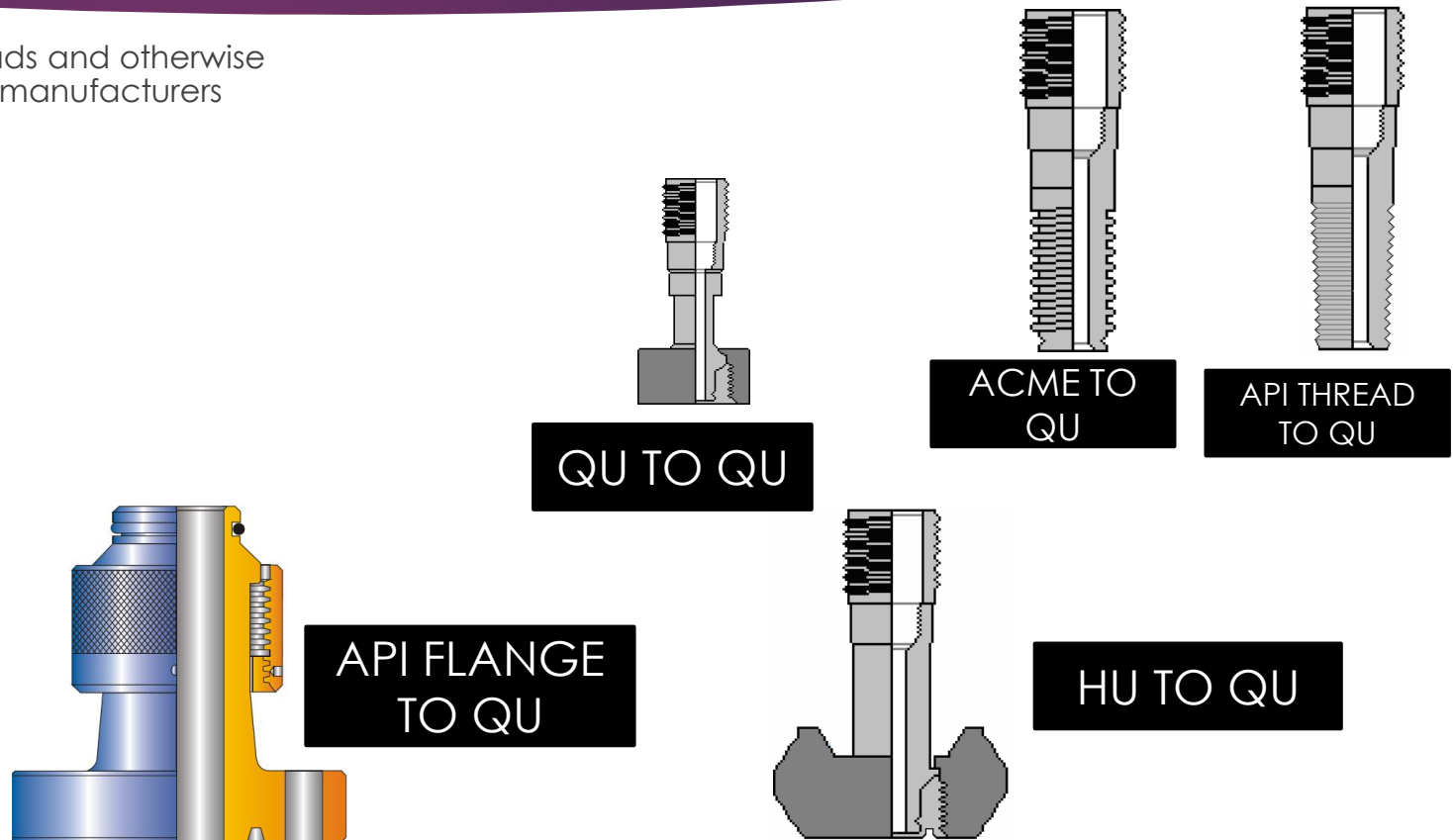

LOW TORQUE VALVE

- ▶ Known as plug valve
- ▶ Requires a quarter turn(90deg) of plug using bar
- ▶ To control the fluid flow by rotating the handle or other similar operation.



CONTROL PANEL

- ▶ Control panel (CP)
 - Operate BOP ram
- ▶ Single well control panel (SWCP)
 - Operate Master valve and Surface control sub safety valve (SCSSV)
- ▶ Well control panel (WCP)
 - Can operate BOP, stuffing box, MV, and SCSSV
- ▶ Air supply
 - Min-75psi, Max 120psi
 - Standard around 100-110psi



CONTROL PANEL
(CP)



SINGLE WELL
CONTROL PANEL
(SCWP)



WELL CONTROL
PANEL (WCP)

PRESSURE TEST UNIT (PTU)

- ▶ To pump in fluid or pressure test the PCE components or similar equipment
- ▶ Fast filling and high pressure pump for testing up to a maximum 15,000 psi
- ▶ Is suitable for use with water/soluble oil glycol
- ▶ The test result recorded by a chart

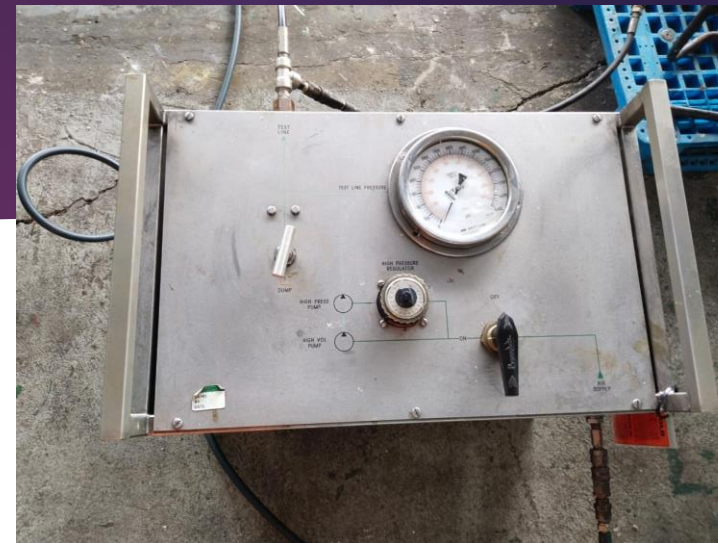
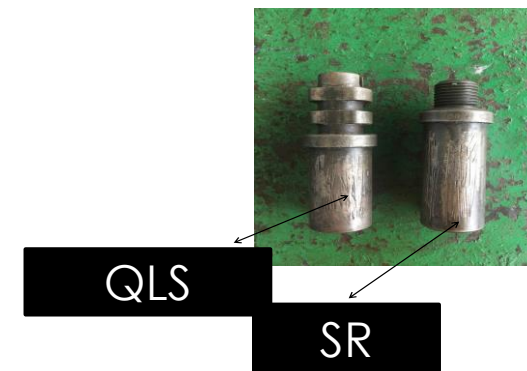

Chart recorder

Connection

- Sucker Rod SR
- Quick Lock System QLS
- Quick Release Joint & HD QRJ
- Trinity Δ
- Common used by DB : SR & QLS



QLS & SR & Shear Pin Size

SR :

- 1.5/16
- 1.1/16
- 1.9/16

QLS :

- 1.1/2
- 1.7/8
- 2.1/2

Shear Pin (Brass, Aluminium & Steel) :

- 1/8
- 3/16
- 1/4
- 5/16
- 3/8



BASIC TOOLSTRING

- Rope Socket
- Swivel Joint
- Stem
- Link jar

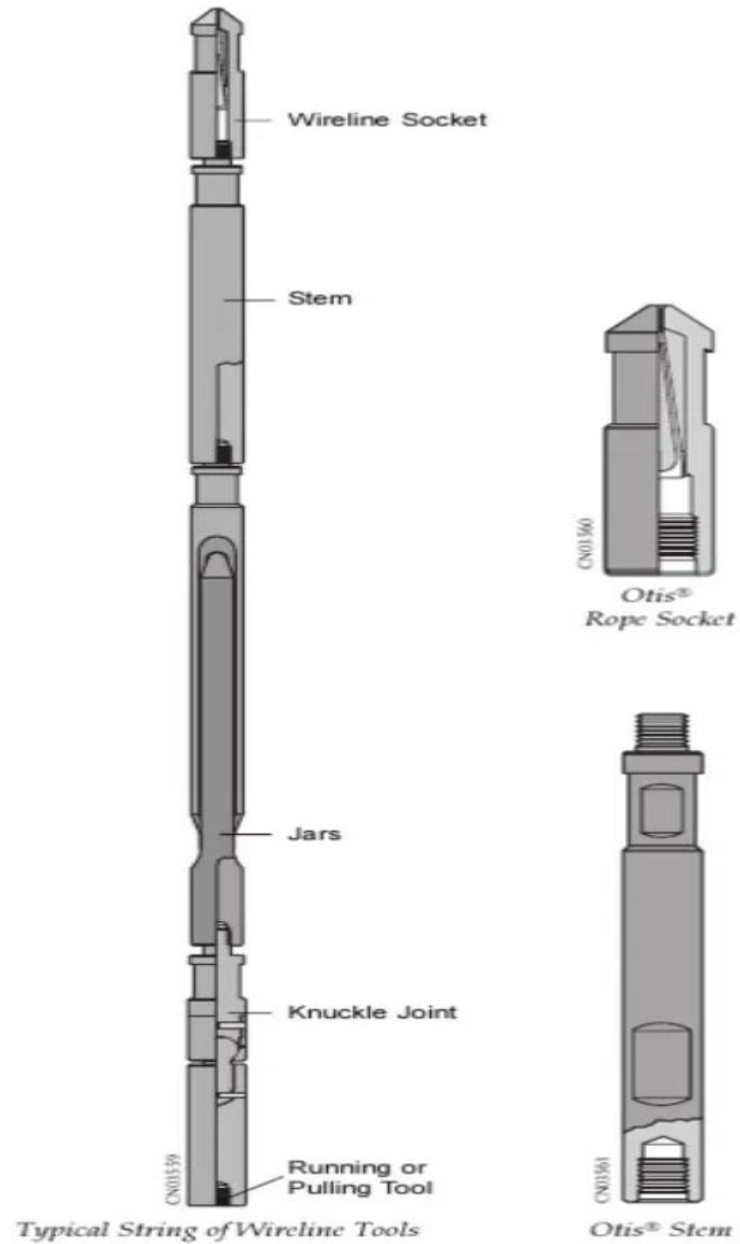

ROPE SOCKET

- Used as a method of connecting the Slickline wire to the tool strings, from wire sizes 0.108" 0.125 and 0.140"
- 3 types : Pear Drop (Common use by DB), Spring, Disc and braided clamp type)
- For tubing 3.1/2 Rs size 1.7/8, tubing 2.7/8 Rs
 - ▶ size 1.1/2, tubing 2.3/8 Rs size 1.1/4



PEAR
DROP RS



PEAR DROP RS COMPONENTS

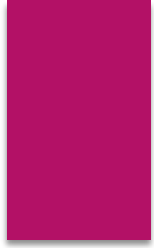

SWIVEL JOINT

- Swivel joint used to minimize the effect of the wire twist
- Double fishneck and have bearing inside
- Sideways movement of swivel varies from 1.5° to 5°



Stem (Sinker Bar/Weight Bar)

► Type :

- Normal
- Roller
- Lead filled
- Tungsten

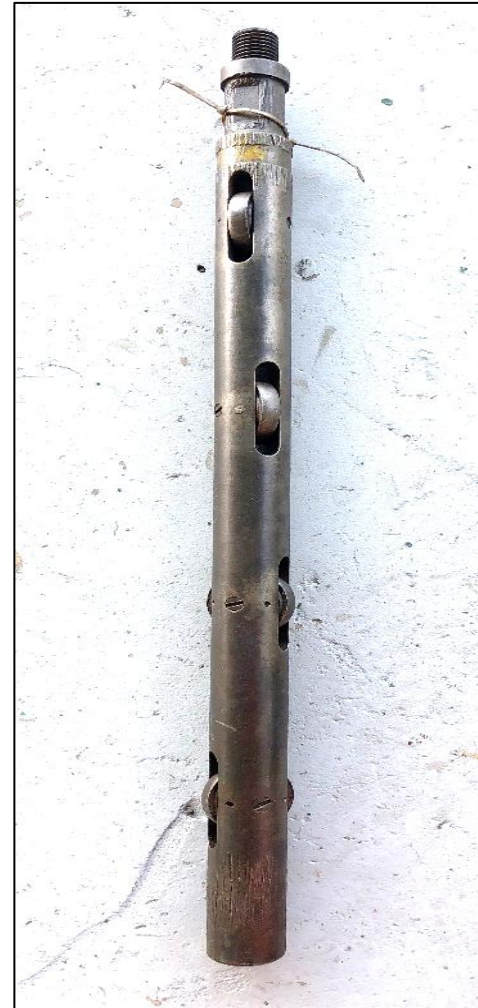

LINK JAR

Types :

- Mechanical
- Upstroke
- Spring
- Hydraulic
- Tubular



Mechanical/Spunk
/Stroke



Upstroke



Hydraulic



Spring



Tubular

KNUCKLE JOINT

- Used to add flexibility within the tool string
- Effective within deviated well bores
- 15° angle movement

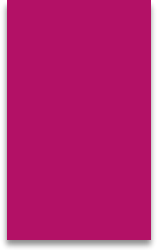

SPECIAL SERVICES TOOLS

- Tubing Drift
- Wire Scratcher
- Lead Impression Block LIB
- Fluted Centralizer
- Blind Box
- Gauge Cutter
- Tubing Swage
- Tubing Broach (Diamond cut & Straight cut)

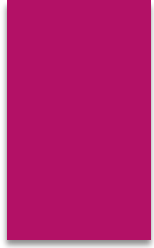

PULLING TOOLS

- SB
- SS
- SSSJ
- RB
- RS
- GS
- GSL
- GU ADAPTER
- GR
- PCE HD
- JUC
- JDC



SHIFTING TOOLS

- Otis B / 42BO
- Otis BO / 142BO
- X Shifting

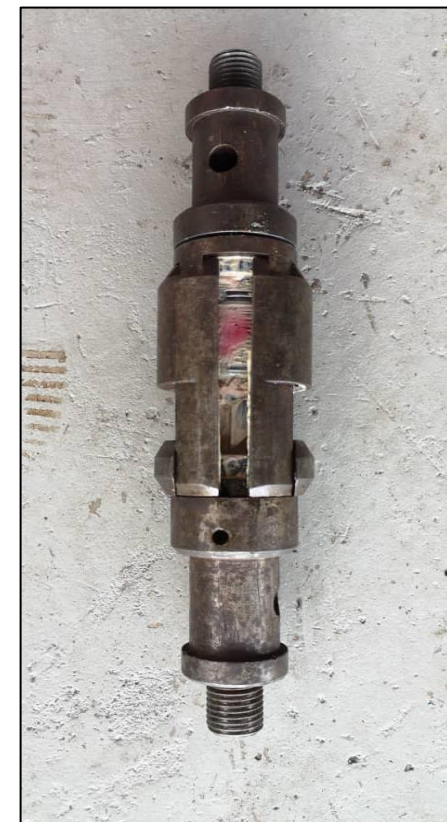

FISHING TOOLS



- Wire Grab
- Alligator Grab
- Sidewall Cutter
- Go-Devil
- Wire Finder
- Wire Cutter
- Overshot

GAS LIFT TOOLS

- OK-6 Kick-Over Tool
- Catcher Sub
- Gas Lift Valve Latches

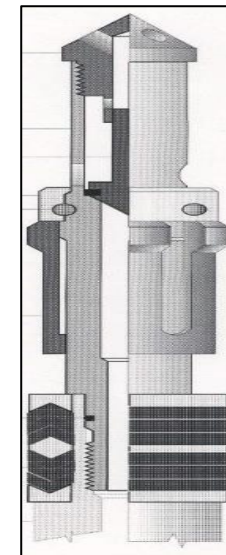

THANK YOU

