

Coiled tubing technology, principles, procedures & troubleshooting

Presented by:

Engineer Samer Shukri

10-12th May, 2021

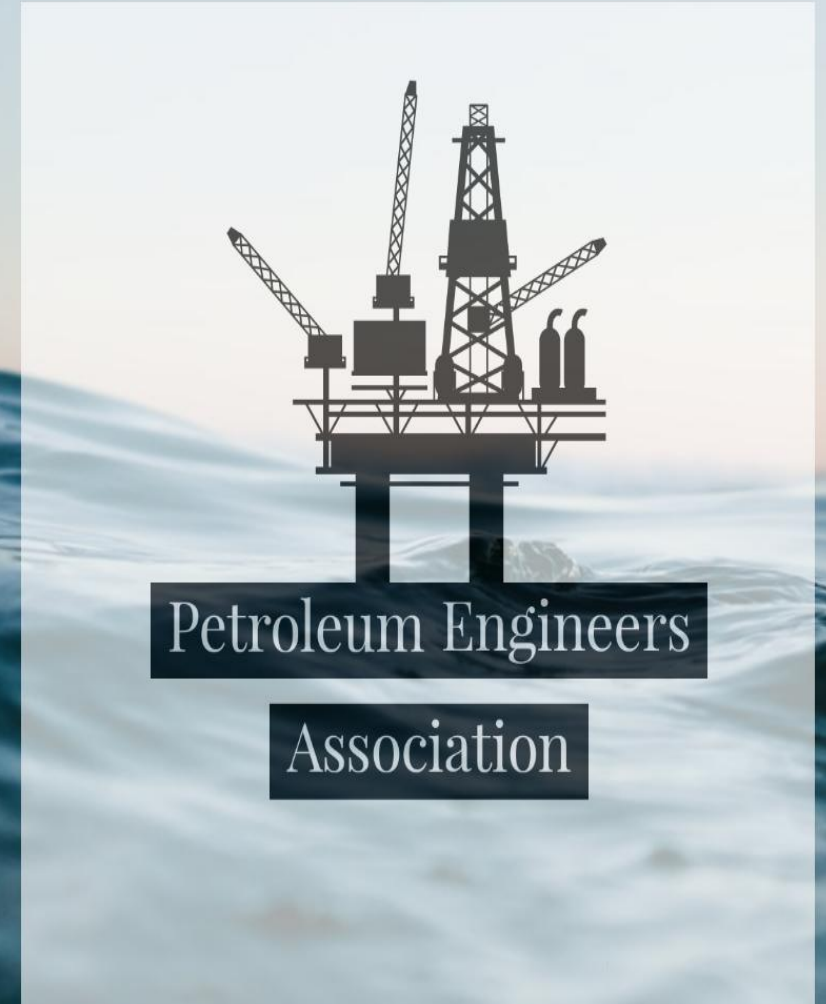

Instructor's information

Name: Engineer Samer Shukri

Qualification: BSc of Petroleum Engineering

University graduation date: 1995

Nationality: Turkish

Experience years: more than 25 years in oil and gas

Work experience: Workover, Well services,

Production engineering, Well integrity, IWCF

Certification, International instructor from UK

I worked for several reputable oil companies

Such as Syrian petroleum company, Shell-Syria,

Abu Dhabi onshore company ADCO and IWCF instructor

Linkedin profile: Samer Shukri



الشركة السورية للنفط
Syrian Petroleum Company

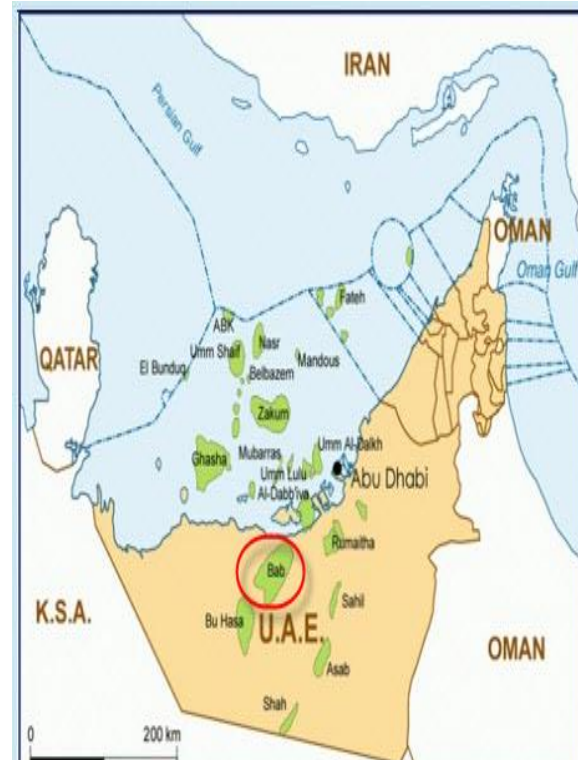
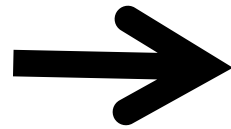
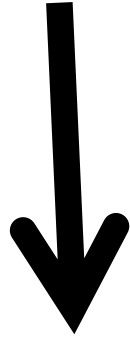
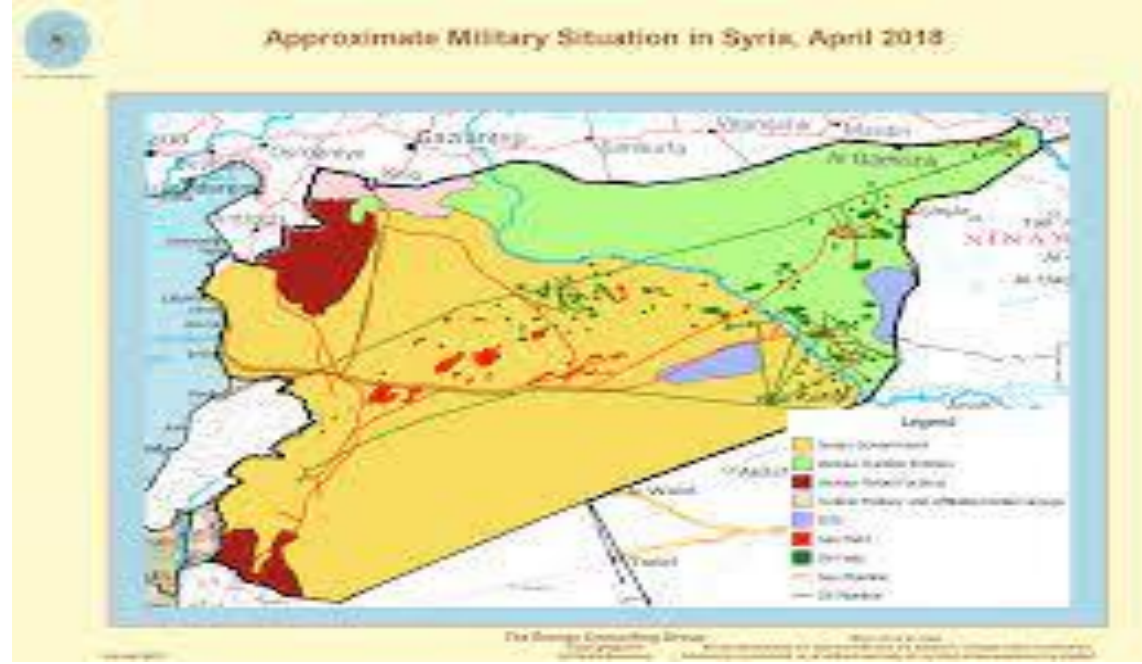

TM

International
Well Control
Forum

Assessment Outcome

ECTP Train the Trainer

Student name:	Samer Şukri					
Course date:	15-18.03.2021					
Course location:	Virtual Classroom					
TJS Assessor:	Tracey Jayne Little					
Pre-assessment task outcome (Teaching 3)	Samer was well-prepared and shared the activity in advance. Good introduction PPT and open question. Learners then were moved to breakout rooms with the same PPT slid and were unsure what to do. This resulted in loss of time for the actual activity – answering 6 quiz questions so Samer started telling one group the answers leaving only 1min 30 for learners to work on the exercise in one group. Samer needs to facilitate not tell. Samir is very encouraging; feedback after the activity was too little at only 2mins. Samir needed to go deeper. The summary was teacher-centred and the session was under-time at 11min 05 as it needed more interaction.					
Assessment outcome (Teaching 4)	<p>Pass</p> <ul style="list-style-type: none"> - Very detailed lesson plan; excellent structure in delivery using signposting language "let's move on to" to help the flow. On time at 20min 02 - High learner engagement - frequent open question and lots of TED - Involves all learners – uses names frequently - The activity matched the needs of the group and was well thought through - Huge enthusiasm and passion shines through and keeps the learners connected. Samer needs to modulate voice and have more natural pauses. 					
Trainer's strengths:	<ul style="list-style-type: none"> • Excellent planning for delivery - methodical • Very good learner engagement – highly encouraging, frequent open questions and feedback after the activity • Excellent communication skills and passion. 					
Areas for development:	<ul style="list-style-type: none"> • Modulate voice more and use pauses • Facilitate more actively during an activity • Have less information on PPT – separate out the activity from the introduction text. 					
Overall comments:	A passionate and methodical trainer who has developed hugely during this course, listened to and acted on feedback and mastered student-centred training.					
Contribution on course:						
Attitude	Excellent	Very Good	Good	Fair	Poor	N/A
Participation	Excellent	Very Good	Good	Fair	Poor	N/A
Open to new ideas	Excellent	Very Good	Good	Fair	Poor	N/A
Acts on feedback	Excellent	Very Good	Good	Fair	Poor	N/A
Enthusiasm	Excellent	Very Good	Good	Fair	Poor	N/A
Award:	Pass – a strong pass at 87%.					



TM

**International
Well Control
Forum**

This is to certify that

Samer Sukri

has been awarded

Pass

in the

IWCF Train the Trainers Course

Delivered by:



IWCF Chief Executive Officer:



TJS Director:



Date: 18-03-2021

Certificate No: IWCF-TT-0383

If any colleague or training center wants to communicate with me, please see my details:

- ❑ Facebook: Samer Shukri
- ❑ LinkedIn: Samer Shukri
- ❑ You tube: Samer Shukri
- ❑ E-mail: samerws@yahoo.com
- ❑ Mobile: 00905385159624

- ❑ Position: IWCF instructor-Well intervention
Oil and gas trainer
Well services consultant

Petroleum Engineers Association PEA is an ad-tech company ISO 9001, 2015 certified and MSME registered in India

It was started in May 2020

Directs towards the extension of fundamental understanding of oil and gas industry among the young professionals worldwide.

The events are designed to offer a unique opportunity to the participants to interact with the prominent experts from industry, and faculty from premium academic institution.



CONTACT US

For any Queries
Mr. Nikhil Agawal



+91-6203835588
+91-7763084919



+91-6203835588
+91-9570412084



peassociations@gmail.com



Petroleum Engineers Association



Petroleum Engineers Association



www.petrocation.com

THANKS & REGARDS



Mr. Nikhil Agarwal
+91-6203835588

PETROLEUM ENGINEERS ASSOCIATION



Agenda

- Introduction to CT
- Introduction to IWCF certification
- Well control calculations
- Well and completion types
- Completion components
- Wellhead – Xmas tree components
- Wireline operation before moving CT to the well site
- CT definition and uses
- Safety of CT
- Components of CT package
- Standard rig up of CT equipment
- CT barrier theory

- ❑ Pressure containment devices (primary barrier):
 1. Stripper
 2. Check valve
- ❑ Pressure containment devices (secondary barrier):
 1. Dual
 2. Triple
 3. Quad
- ❑ Pressure containment devices (secondary barrier):
Shear/seal BOP
- ❑ Typical CT surface stack
- ❑ CT applications:
 1. CT cement plug
 2. N2 kick off or lifting
 3. CT conveyed perforation
 4. Open and close SSD's in horizontal completion

5. Well stimulation:

- Acidizing
- Hydraulic fracturing
- Fracture acidizing

6. Hydraulic fracturing

7. Scale and sand clean out

8. Milling

9. Fishing

10. Pumping: applications

- Working in H₂S environment
- Risk assessment matrix
- Hazards zone classification
- Personal protective equipment PPE

- ❑ Life saving roles
- ❑ Macondo well-Deep horizon disaster
- ❑ 3 persons died in H₂S incident
- ❑ CT emergency response procedures:
 1. CT parted at surface between reel and injector head
 2. CT parted downhole
 3. CT Parted between injector head and stripper assembly
 4. Stripper assembly leaks
 5. Hole in CT above stripper at surface
 6. Surface leak above shear/seal BOP
 7. Pump Failure
 8. Check valves are not holding pressure
 9. Power pack failure
 10. Platform shut down

Experience exchange

1. Station shut down during N2 lift operation
2. CT power pack got fired while CT in hole
3. During sand clean out operation using 1.5" CT, the pump heated up and then stopped working
4. During N2 kick off operation in a well with high temperature, tubing got stuck due to buckling as a result of high temperature fluid being produced through the tubing
5. During sand clean out operation using 1.5" CT, the CT got stuck in hole and we were unable to retrieve it
6. During displacing the well fluids from brine to diesel to reduce hydrostatic pressure on the formation and allow the well to flow, leak occurred from stripper
7. During RIH CT while pumping fresh water at 1.5bpm and CT pressure is 5000psi, CT got ruptured between the reel and injector head

Introduction:

- Coiled tubing provides well intervention services that substantially reduce costs for many workovers, remedial & specialized drilling operations formerly requiring a rig
- Common CT size ranges from 1-1¾ inch. Due to current economical changes & CT advance technology larger size ranges from 2-3½inch
- CT can easily be transported, rigged-up & rigged-down in a short period of time, Offshore - 3hrs & Onshore 1½hrs
- Currently maximum working depth is 25K feet @ 250 ft/min running speed
- CT is cheaper & faster
- Alternative method to perform downhole works compared to conventional methods

International well control forum IWCF certificate

In order to prepare for this international certificate, you have to study the following subjects:

- Completion equipment
- Completion operation
- Wireline operation
- Coiled tubing operation
- Snubbing operation

There are 4 levels for this certificate:

- Level 1 Familiarization
- Level 2 Introductory
- Level 3 for operators
- Level 4 for supervisors

Well control calculations

1. Hydrostatic pressure: $HP \text{ (psi)} = TVD \text{ (ft)} \times \text{Density (ppg)} \times 0.052$

$$HP \text{ (psi)} = TVD \text{ (ft)} \times \text{Density (pcf)} / 144$$

$$HP \text{ (oil+gas)} = HP \text{ (oil)} + HP \text{ (gas)}$$

$$HP \text{ for column of gas} = CITHP \times \text{Corroection factor}$$

2. Bottom hole pressure: $BHP \text{ (psi)} = HP + CITHP$

3. Reservoir pressure = Bottom hole pressure

4. Specific gravity = $141.5 / (131.5 + API)$

5. Specific gravity = oil density / water densit

6. Pressure gradient = $\text{Density (ppg)} \times 0.052 = SG \times 0.433$

7. Time to pump (minute):

In tubing: $\text{Tubing Capacity (bbl/ft)} \times MD \text{ (ft)} / \text{Pump rate bbl/min}$

In annulus: $\text{Annulus Capacity (bbl/ft)} \times MD \text{ (ft)} / \text{Pump rate bbl/min}$

SINGLE STRING WELL COMPLETION SCHEMATIC

Well and completion types

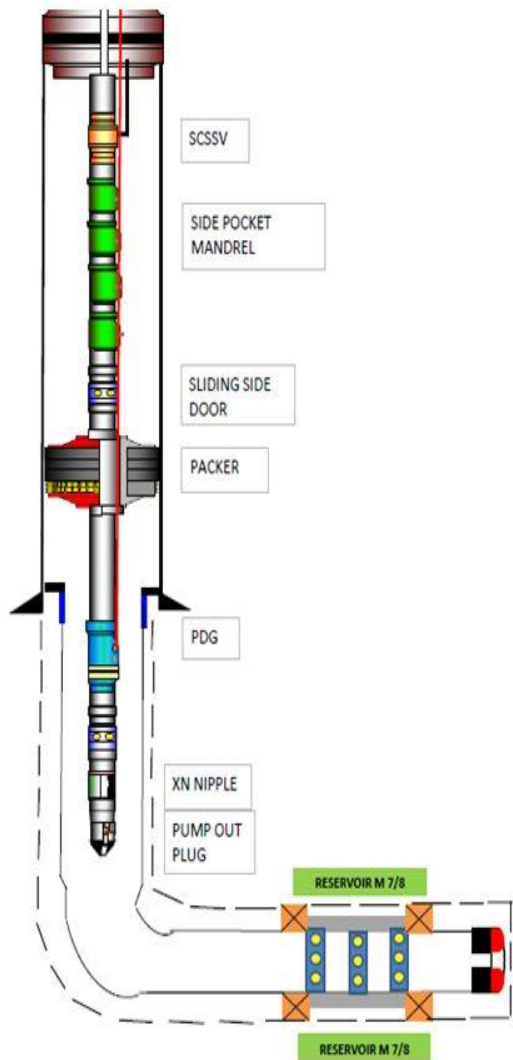

Well type: Oil producer
 Completion type: Single string w/PDG
 Artificial lift: Gas lift
 Zone: M7/8
 Tubing: 3-1/2", 13 Ch
 Completion acc: 9 Cr
 PDG: Electronic
 Sand control: Slotted liner
 Brine: 10ppg
 Packer setting method: Drop ball & chase

Horizontal well

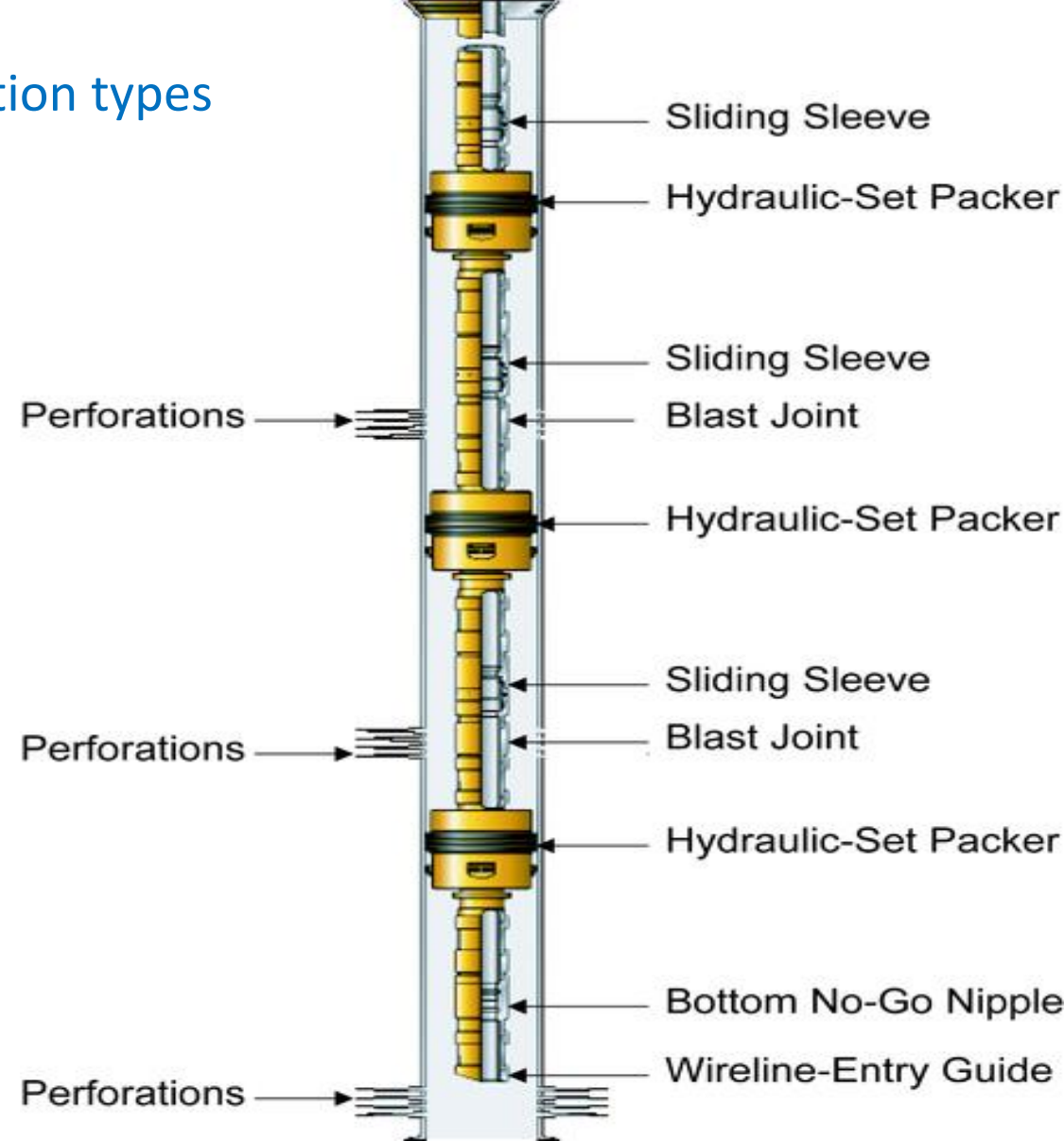

Vertical well

1-Well Head

Completion components

2- Down hole Safety Valve

3- Side Pocket Mandrel

4- Sliding Sleeves

5- Landing Nipples

6- Packers

7- Perforated Joint

A Typical Permanent Completion

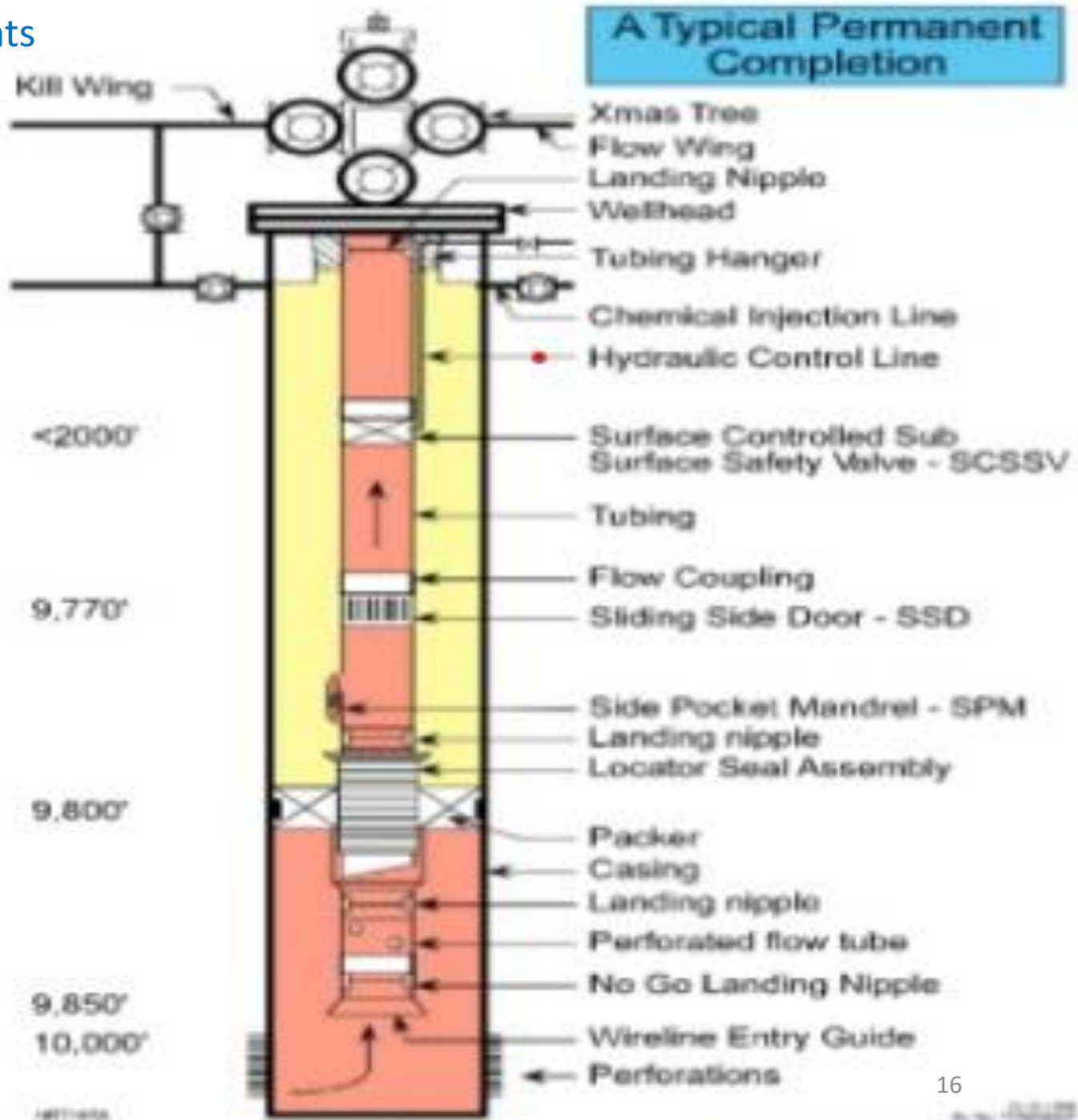

Wellhead: consists of pieces of equipment mounted at the opening of the well to manage the extraction of hydrocarbons from underground formation

It prevents the leak of oil and gas out of the well and prevents blowouts caused by high pressure

Wellhead pressure rating should be suitable for reservoir pressure of the well and may reach to 20000psi

Wellhead consists of 3 components:

1. Casing head including casing hanger and casing head spool
2. Tubing head including tubing hanger and tubing head spool
3. Xmas tree

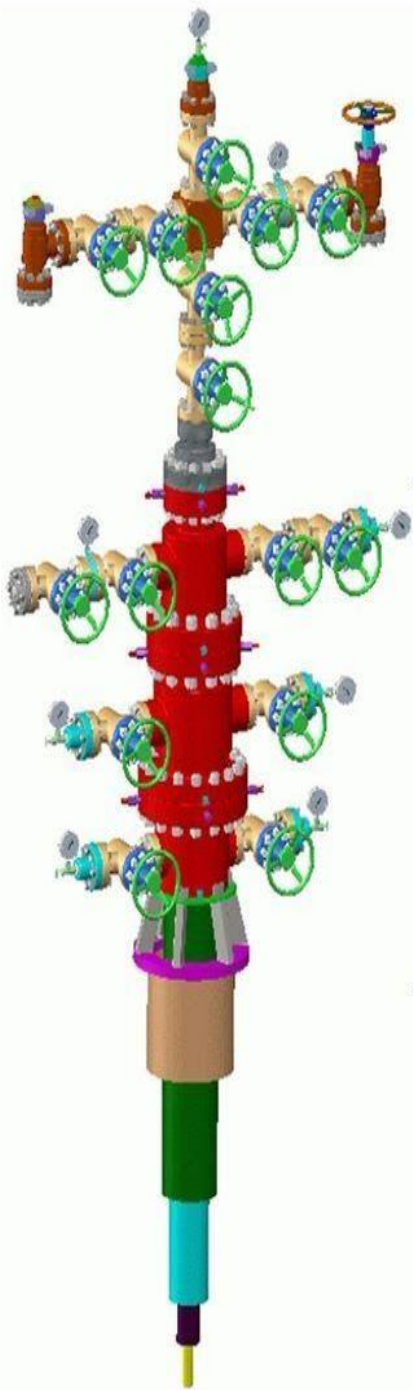

Christmas Tree

Wellhead

Casing

Monoblock tree

Compact spool wellhead

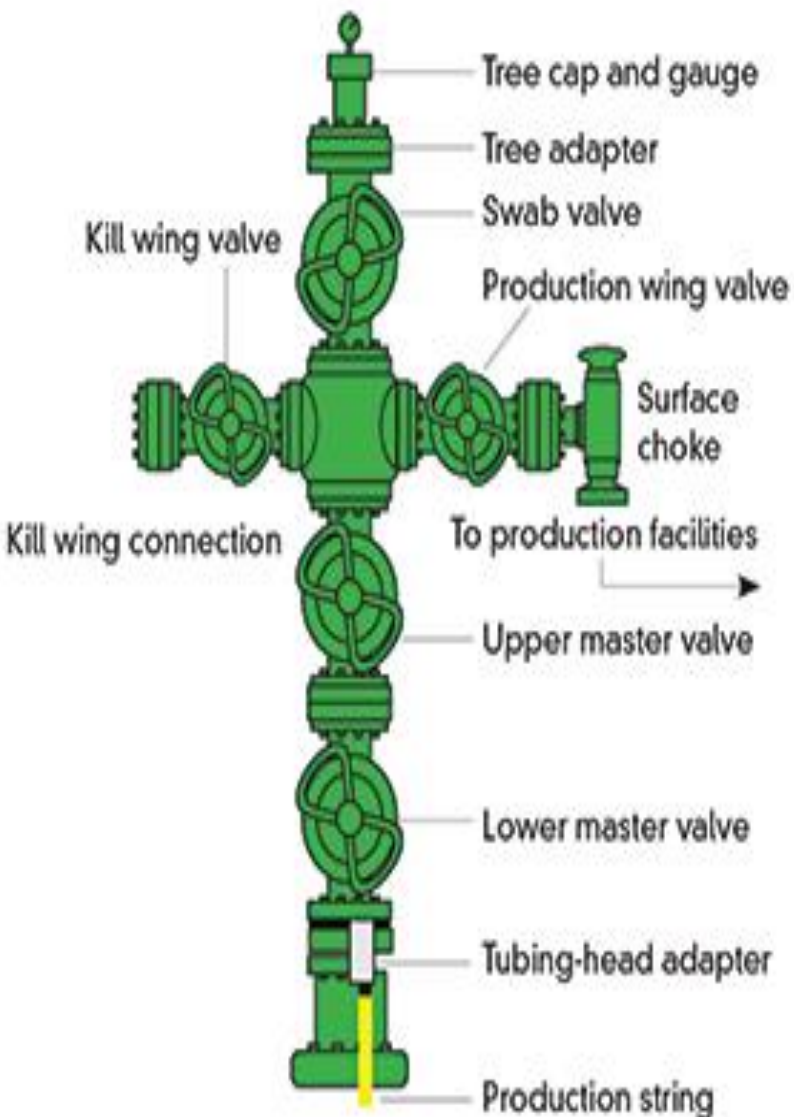
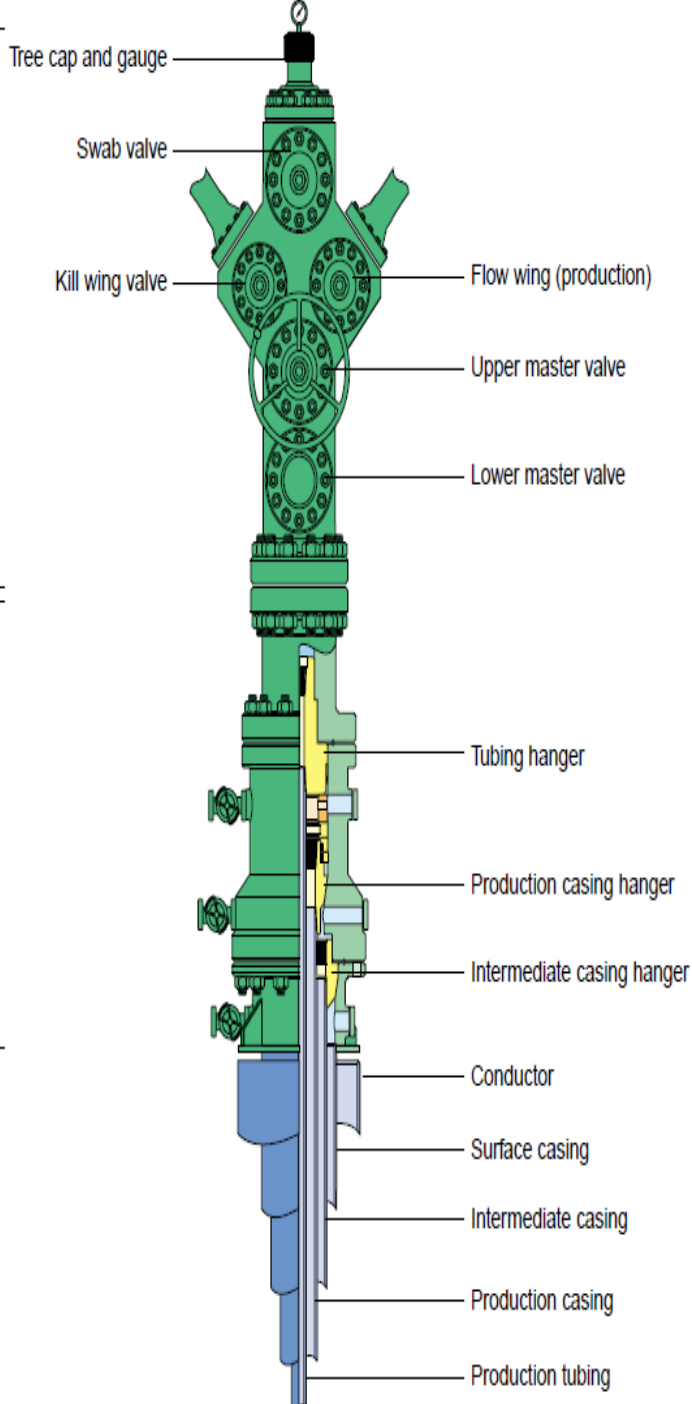

Xmas tree¹⁹



A **Christmas tree** is an assembly of valves, spools and fittings used for oil, gas, water injection, water disposal, gas injection, condensate and other types of wells.

The primary **function** of a **tree** is to control the flow into or out of the well, usually oil or gas.

There are 3 types of Xmas tree:

1. Conventional
2. Mono-block
3. Compact or subsea

Christmas Tree



Wellhead

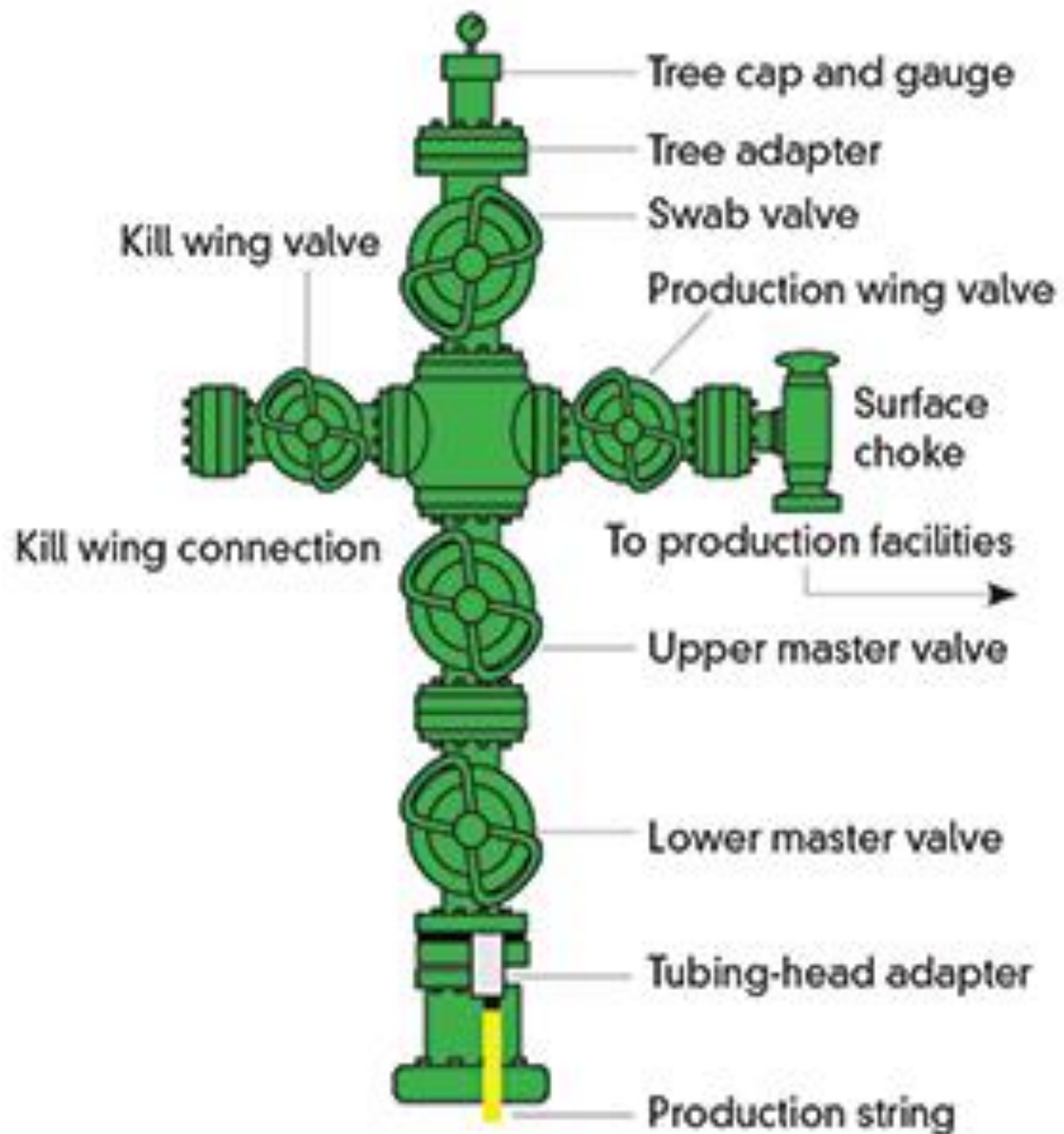



From wellhead to station

Wireline operations before moving CT to the well site:

1. Wireline should carry out drift run before moving CT to ensure that the well is accessible and to avoid any surprise in the last moment
2. WR-SCSSSV should be retrieved before rigging up CT equipment on the wellhead
3. In some cases we have to run wireline to measure reservoir pressure or to collect downhole sample in order to choose the required materials for well treatment and ensure its compatibility with well fluids, i.e. treatment with acid or mud acid fluids
4. It is sometimes required to open or close SSD before running with CT for reservoir isolation to communication
5. It may be required to set wireline plug for isolation

Coiled tubing

- ❑ **Definition:** CT is a continuous string of tubing, rolled onto a spool. It is made from rolling strip material into a tubular form and resistance welding along its length
- ❑ Coiled-Tubing (CT) continues to grow as an enabling technology that provides cost economy and time efficiency for the oil and gas industry
- ❑ It has gained wider acceptance in all operations involved in oil and gas exploration

Coiled tubing

- ❑ It is used when it is desired to pump chemicals directly to the bottom of the well such as circulating operations or chemical works
- ❑ It can also be used for tasks normally done by wireline if the deviation in the well is too severe for gravity to lower the tool string and circumstances prevent use of wire line (inclination is more than 70 degree)
- ❑ If the well is quit due to heavy hydrostatic column in the well, the well can be produced again using N2 lifting by running CT in hole and pumping N2

□ CT can perform the following activities:

1. Logging
2. Cementing
3. N2 kick off
4. CT conveyed perforation
5. Open and close SSD's in horizontal completion
6. Stimulation and fracturing
7. Scale and sand clean out
8. Milling
9. Fishing
10. Drilling

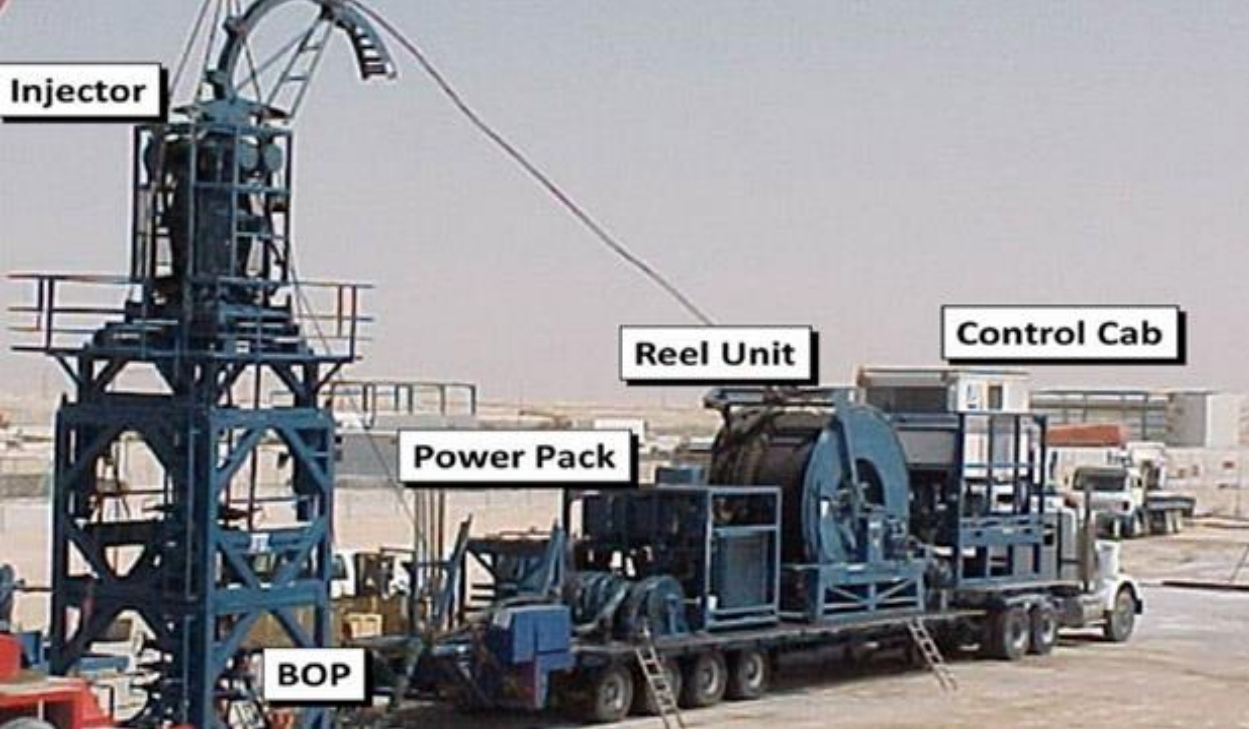

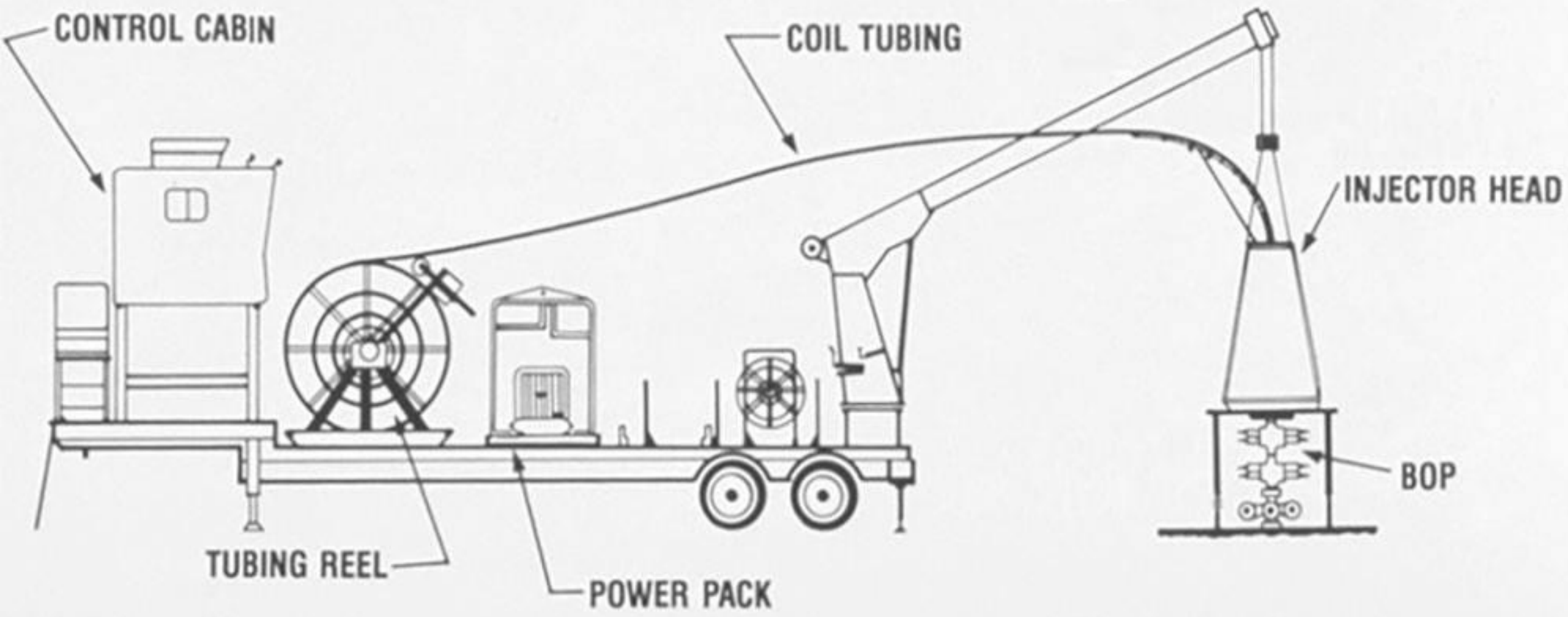

Safety of CT

- ❑ It is a vital practice to ensure that all components of CT package are certified and checked as per international standards to avoid any incident
- ❑ This can include: function test, pressure test, equipment certificates from manufacturers
- ❑ The incident on CT could lead to the following damages:
 1. Damage of equipment
 2. Injury of personnel and could be fatality
 3. Pollution to the environment
 4. Damage to company reputation





CT package components: regardless of working environment CT unit will include the following main components:

1. Control Cabin
2. Power Pack
3. CT Reel
4. Goose Neck
5. Injector Head
6. Strippers
7. BOP
8. Kill Line
9. BHA

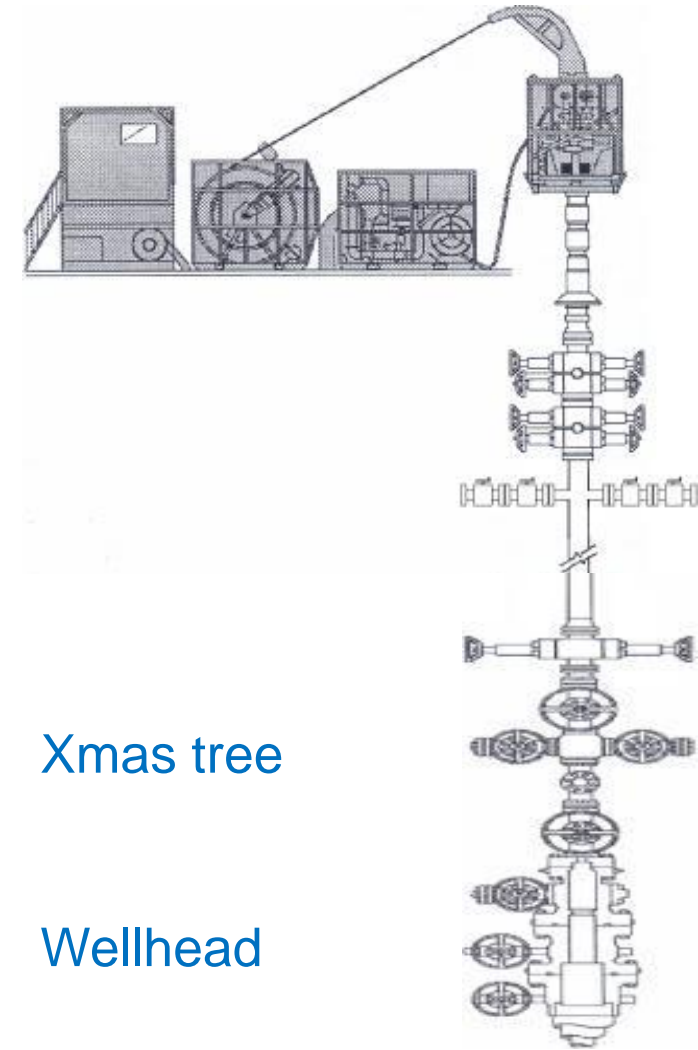

CT rig up for logging on high pressure wells

- ❑ The rig up shown identifies the PCE required for this operation.
- ❑ Rig up sequence from below to up: Quad BOP or dual combi BOP, above it there is deployment stack then 2-3 gate valves then flow spools then combi BOP then stripper then injector head.
- ❑ After making up wireline tool string in the lubricator, rig up lubricator and RIH tool string in hole, stop wireline till deployment bar is against deployment stack, close deployment stack on deployment bar, bleed off pressure in lubricator, rig down lubricator, rig up injector head and PCE blow it, connect CT to deployment bar, equalize pressure then open deployment stack and start RIH.

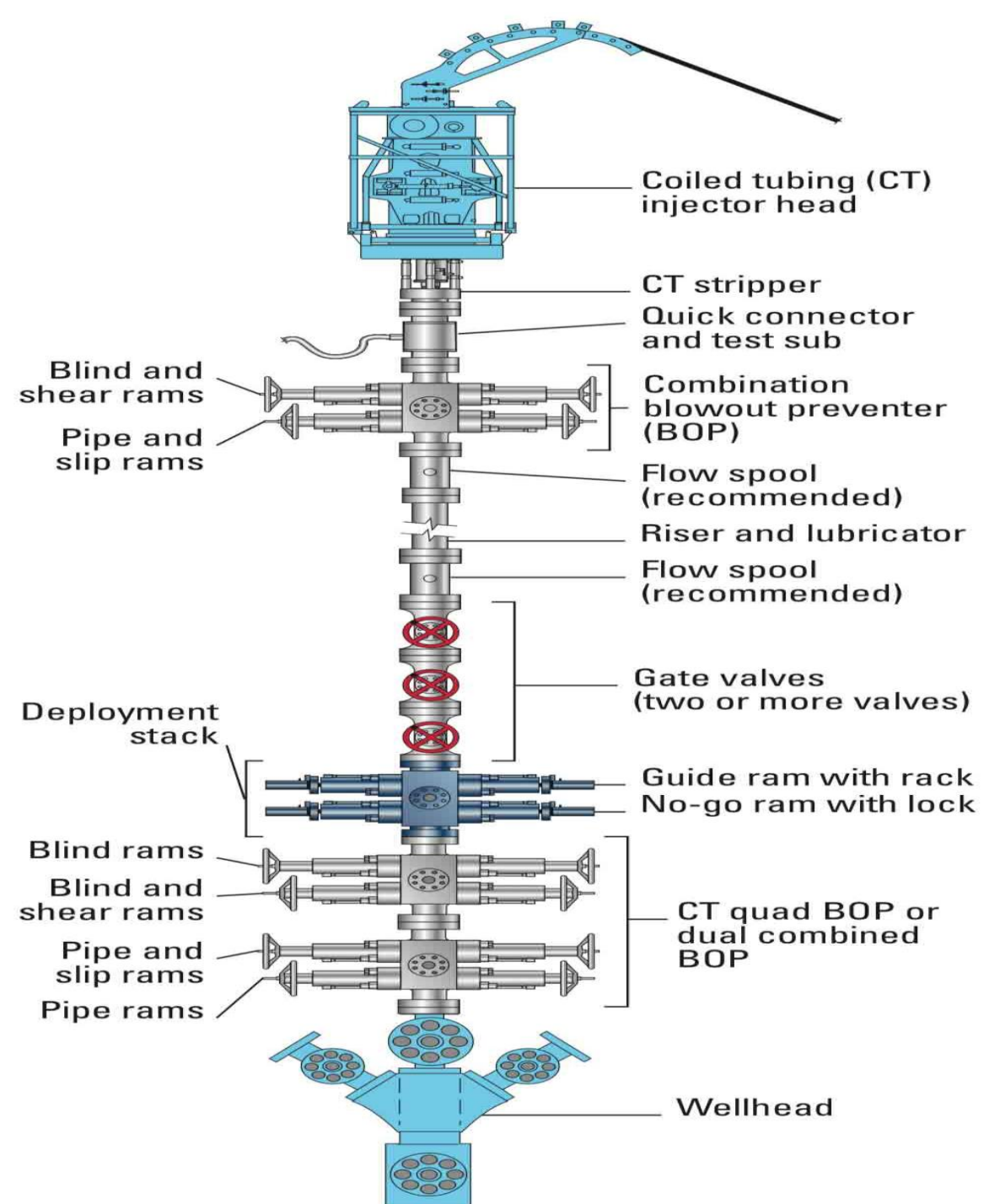

CT barrier theory

- As CT is a type of well intervention, so it needs a minimum of 3 independent and tested barriers

- There are 3 types of barrier for CT:
 1. Primary:
 - External: stripper
 - Internal: DFCV
 2. Secondary: BOPs
 3. Tertiary: shear/seal BOP

Primary Barrier

Upper side door stripper

Lower side door stripper

Secondary Barrier

Blind ram
Shear ram
Slip ram
Pipe ram

Tertiary Barrier

Shear/Seal BOP

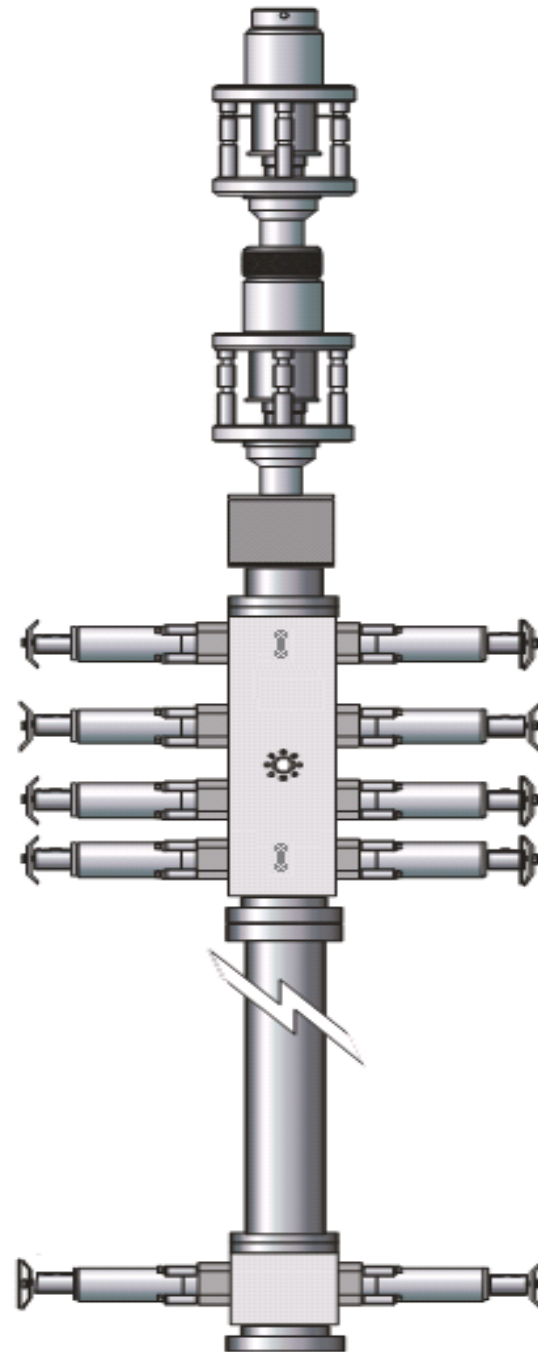

Pressure containment device (primary barrier)-Closed barrier

- Installed above BOP & below injector head
- Dual assembly used for extreme well conditions
- Hydraulic activation from control cabin
- Can be redressed during operation with pressure isolated
- Leak tight (zero leak)
- There are 4 types of stripper:
 1. Conventional Stripper (old type)
 2. Tandem Stripper
 3. Side Door Stripper
 4. Radial Stripper

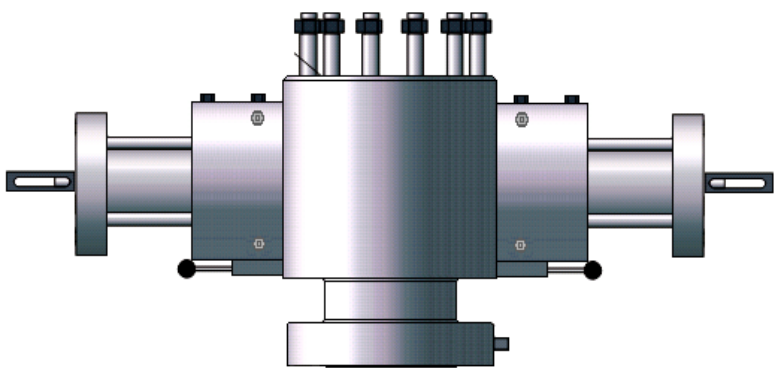

Radial stripper

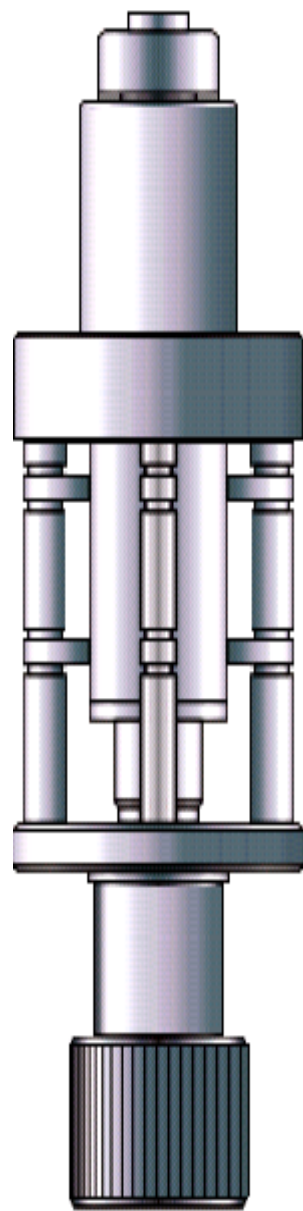

Side door stripper

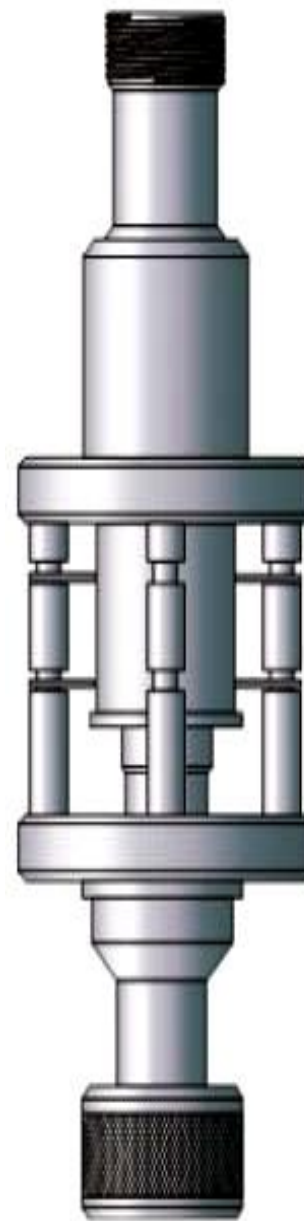

Tandem stripper

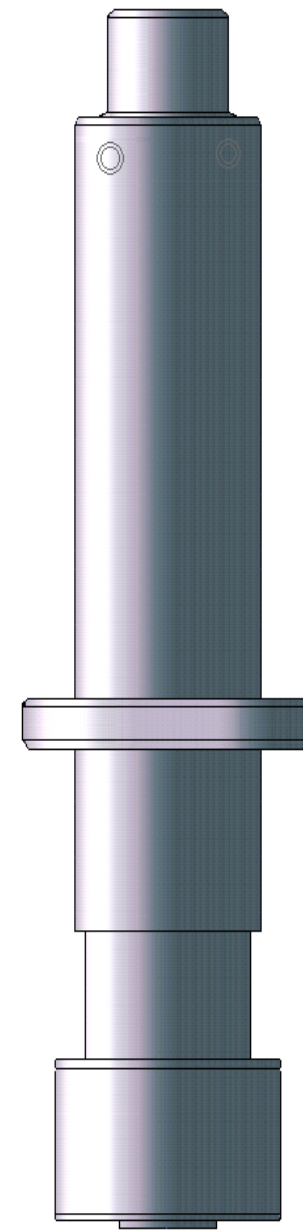

Conventional stripper

Bottom hole assembly: standard BHA consists of the following components:

1. Connector: inline and outline
2. Check valve 1
3. Check valve 2
4. Release sub
5. Circulation sub
6. Tool

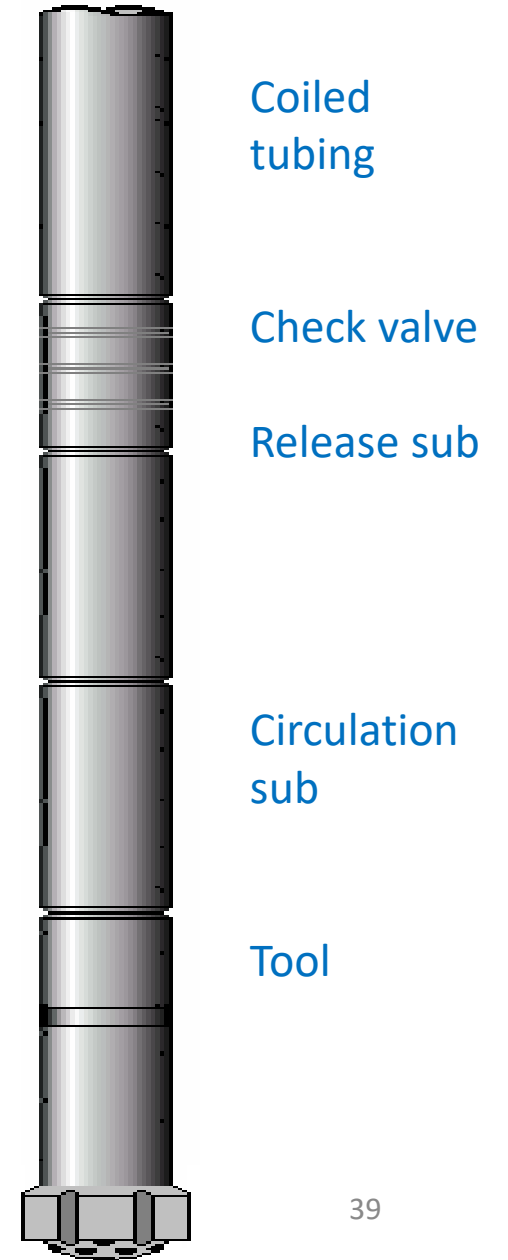

□ Check valves types (internal primary barrier):

1. Ball check valve: metal to metal seal and use when no requirement for ball activated tool
2. Dart or dome check valve: similar to ball type
3. Flapper check valve: full bore design and enables launching of balls

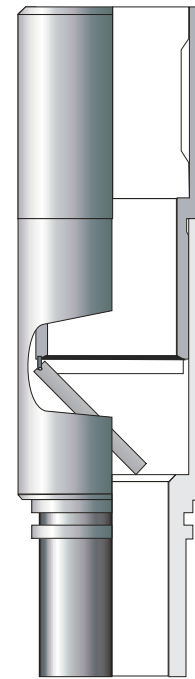

Flapper

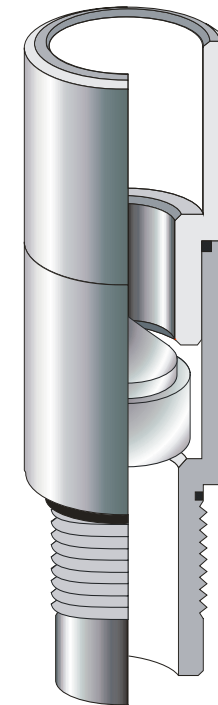

Dart or dome

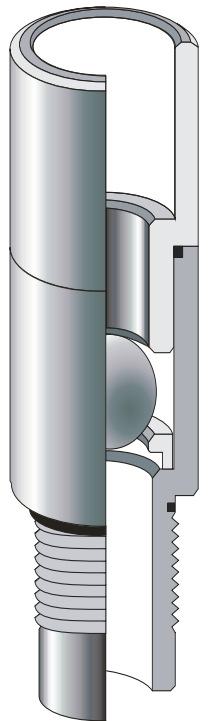

Ball & seat

Pressure containment devices (secondary barrier): blow out preventers BOPs

There are 2 types of preventers: Ram type & Annular type (closable barrier)

□ Ram type: there are 3 types:

1. Dual
2. Triple
3. Quad

□ Annular type:

1. Seals around different ODs
2. Used with long BHAs
3. Closes from bottom to up
4. Well pressures support the closing
5. Seals with and without pipe in BOP



Combi

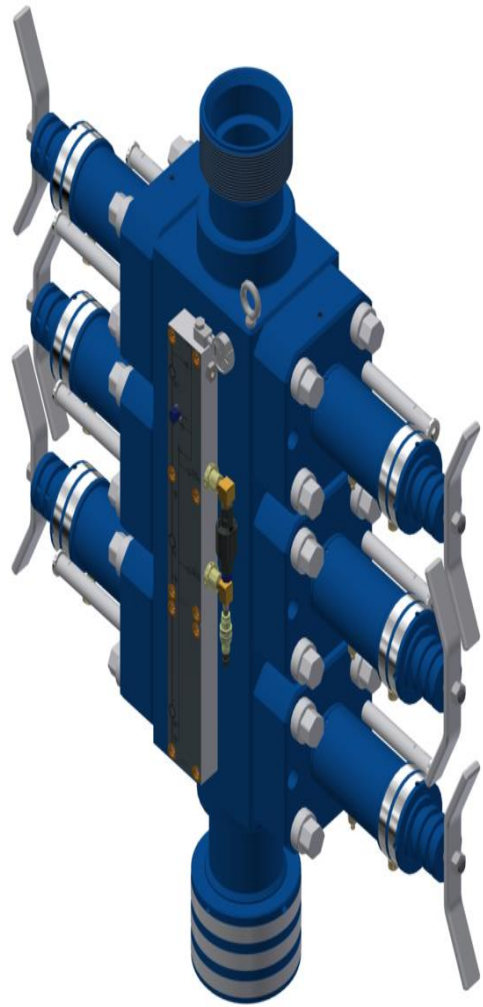

Triple

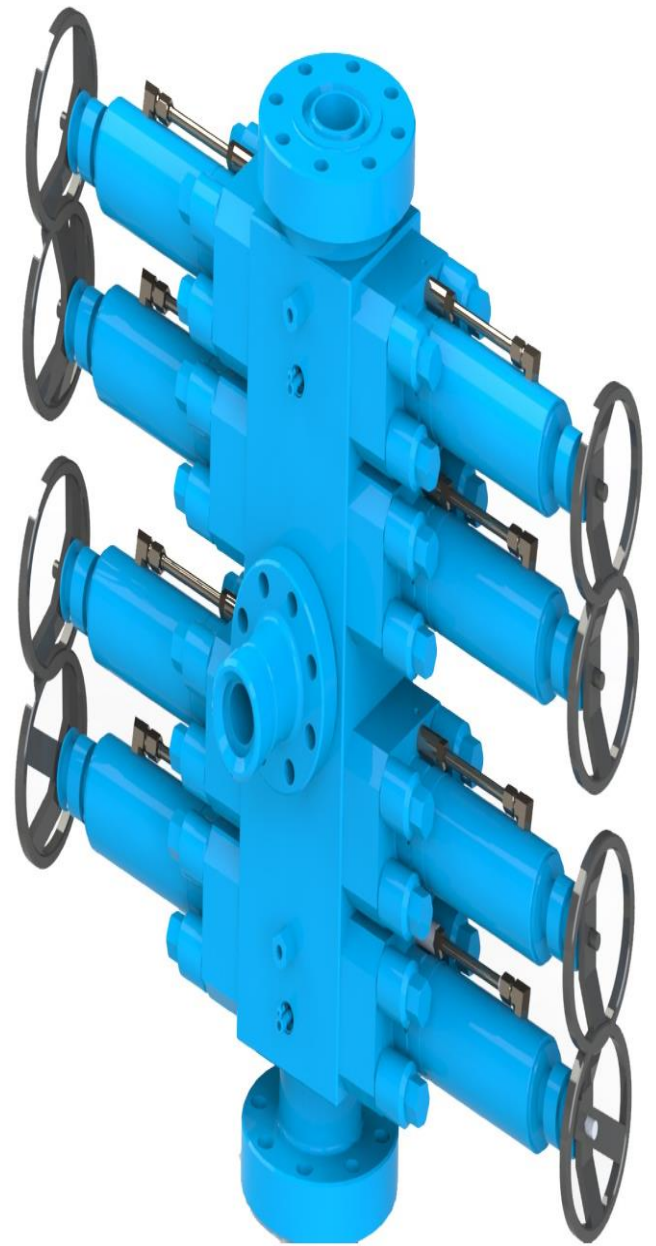

Quad

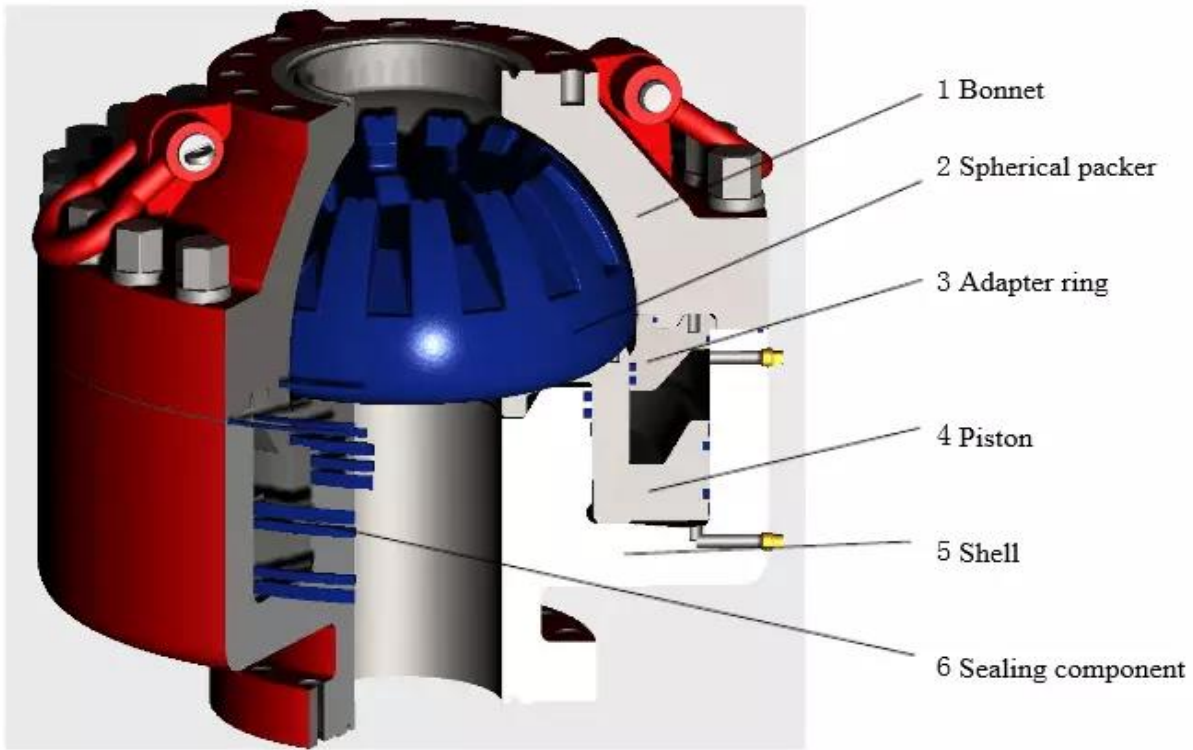
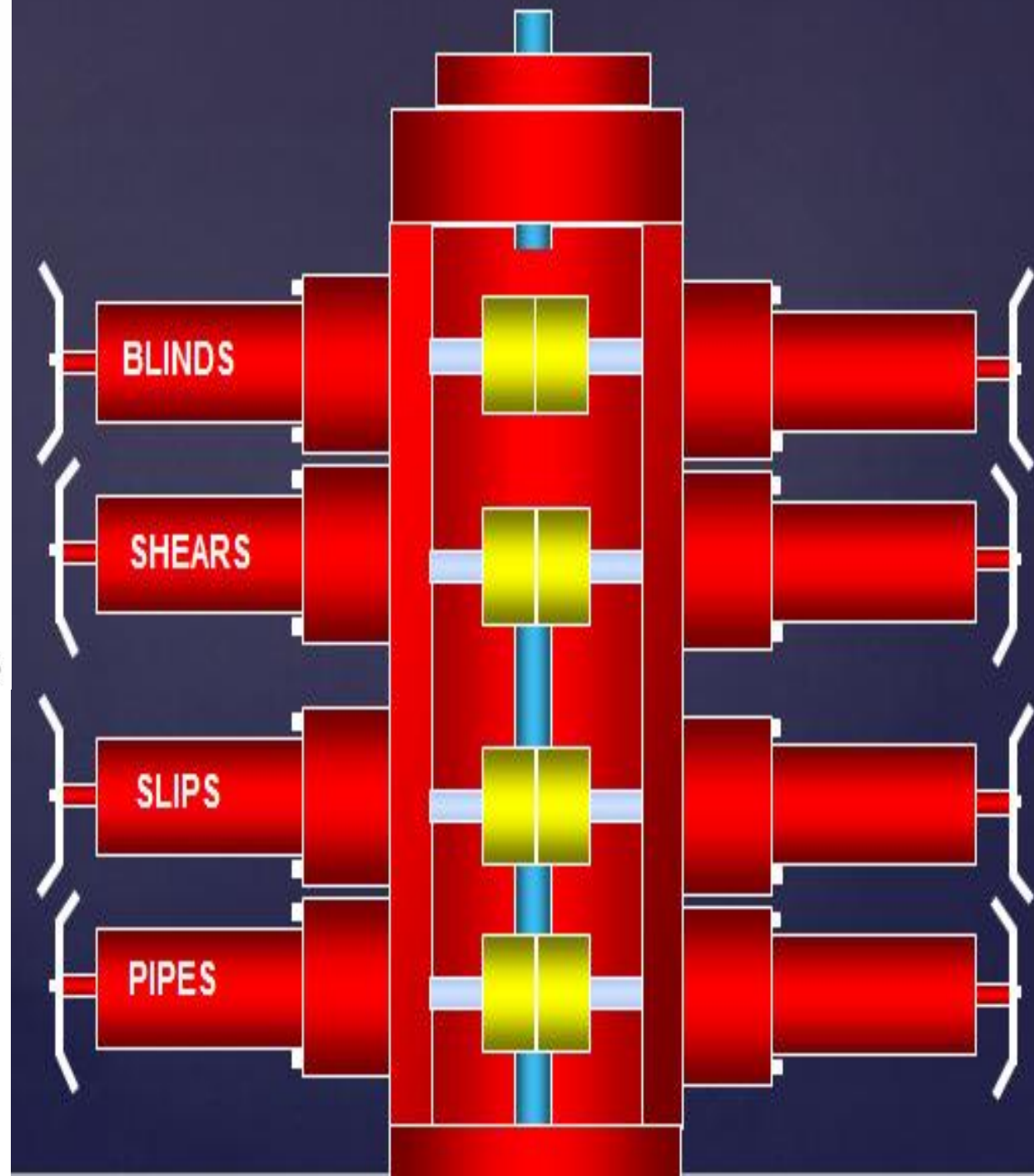

Figure 1 FH35-35/70 Annular BOP (Between bonnet and shell is flange connection)



Pressure containment devices (tertiary barrier): shear/seal BOP

This BOP is the third line of defense, as it is used in case of primary and secondary barriers failed

When it is activated, CT will be dropped down the hole then secure the well and close SWV and UMV

CT dropped in the well is afterwards planned to be fished

After activation, CT drops in hole and seal will be achieved



Typical Coiled Tubing Surface Stack

