



SLICKLINE ASSISTANT WORKBOOK

IMPORTANT NOTE:

1. Your point of reference to complete this workbook may be obtained from the following
 - Training Manual and any other training materials provided together with this workbook
 - Your Trainer, Assessor (Slickline Operator), Verifier (FSM) or senior colleagues
 - SOP / Quality Procedures & Processors
2. The completion of this Workbook is a joint effort and responsibility between you and your assessor therefore you have the obligation to request from your assessor to be assessed upon your completion of each topic
3. The completion of this Workbook is part of the MANDATORY requirements which you must fulfill to qualify for a promotion
4. Your training program is mostly self-driven, including this Workbook. It requires individual initiatives, dedication and commitment to complete the process.

ALLEYSON AKIN
DIMENSION BID (M) SDN BHD
Fast Malaysia Operation

NAME	Albert Pelasari
DATE OF JOIN	
CONTACT NO.	
RECEIVED DATE	
DATE COMPLETED	

TABLE OF CONTENT

Topic	Page
Introduction	2
Public Course Records & In-house Training Records	3-5
Module 1: Basic of Wireline - Equipment and Operation	
Assessment Summary	7
Wireline Operations Basic Safety	8-14
Basic Surface Equipment	15-40
Basic Downhole Tools	41-46
Basic Rig up Wireline Surface Equipment	47-50



INTRODUCTION

CORPORATE PROFILE

Dimension Bid is a Malaysia-based International Well Intervention and Perforation Services company, specializing in Slickline Intervention, Cased Hole Electric Line Logging, Coiled Tubing Services and Braided Line Fishing. Established in 1994 and home-grown, Dimension Bid has developed into a full-fledged intervention service company, having more than 20 years of experience in providing services to National Oil Companies and Multi-National Oil Companies domestically and internationally. Our footprint is located across Malaysia, South East Asia and Central Asia, reflecting our ambition to be a truly global Well Intervention Solutions Partner.

THE GROWTH

Growing from strength to strength our list of client includes Sarawak Shell, ExxonMobil, PCSB and Talisman-Energy Malaysia Limited, ROC Oil, just to name a few. Our involvement expanded from production drilling operations

OUR TEAM

From a humble beginning of 18 employees in 1997, Dimension workforce has now grown to over 200 employees. we believe in realizing full potential of every employee - reason for substantial investment allocated to train everyone, both locally and abroad, in order to achieve the expected high performance and professionalism.

MISSION

To enrich client's business through our expertise in providing an integrated, high-value added solutions in the oil and gas industry.

VISION

To be a Solution Partner of choice to our clients.

THE PHILOSOPHY

Continuous pursuit of excellence in anything we do.



PUBLIC COURSE RECORDS

1. Offshore Safety Orientation

Date Training	Venue	Expiry Date

2. Sea Survival

Date Training	Venue	Expiry Date

3. Basic Fire Fighting

Date Training	Venue	Expiry Date



4. H.U.E.T

Date Training	Venue	Expiry Date

5. Permit to Work

Date Training	Venue	Expiry Date

6. IWCF

Date Training	Venue	Expiry Date



Module 1: Basic of Wireline - Equipment and Operation

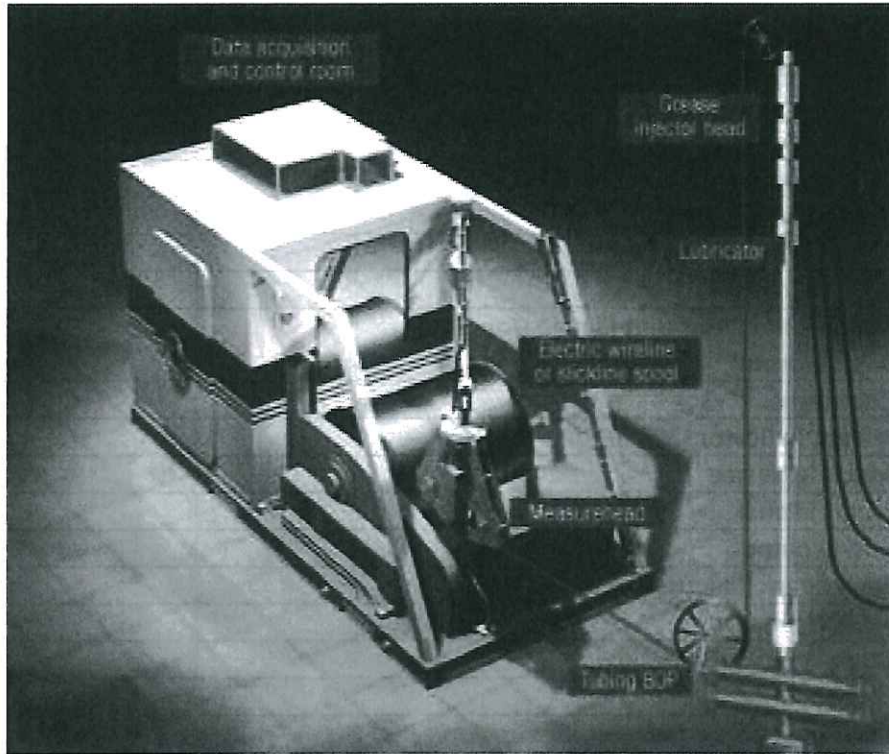

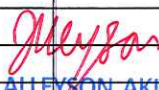
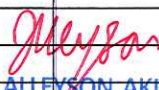
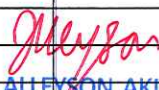
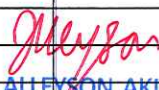

Module 1: Basic of Wireline - Equipment and Operation

DESCRIPTION		THEORY & ASSIGNMENT			
		DATE	ASSESSED & APPROVED BY	VERIFIED & APPROVED BY	
A	Basic Safety				
1	PPE	28/10/22	 ALLEYSON AKIN DIMENSION BID (M) SDN BHD East Malaysia Operation		
2	Responsibilities				
3	Policies				
4	Hazard ID & Incident Report				
5	Operational Safety				
B	Surface Equipment Familiarization				
1	Stuffing box	28/10/22		 ALLEYSON AKIN DIMENSION BID (M) SDN BHD East Malaysia Operation	
2	Lubricator				
3	Blow Out Preventer (BOP)				
4	X-Mass Tree				
5	Wireline Reel Skid Unit (Single Drum & Double Drum)				
6	Odometer				
7	Weight Indicator (200 lbs and 4000 lbs)				
8	Spooling Device				
9	Control Panel				
10	Huskel pump				
11	Power Pack (Electrical & Diesel)				
12	Air Compressor				
13	Drum				
C	Downhole Equipment Familiarization				
1	Basic Toolstring	28/10/22	 ALLEYSON AKIN DIMENSION BID (M) SDN BHD East Malaysia Operation		
2	Pulling / Running Tools				
3	Wireline Wire				
4	Inspection / Maintenance of Tools				
D	Rig-up Wireline Surface Equipment				
1	Wireline Mast	28/10/22		 ALLEYSON AKIN DIMENSION BID (M) SDN BHD East Malaysia Operation	
2	Lubricator Assembly				
3	Operating the BOP				
4	Make Rope socket and Toolstring Configuration				
5	Toolstring Configuration				
6	Operate the Control Panel and Huskel Pump				
7	Service of basic wireline tools				

Comment:



design

A. Wireline Operation Basic Safety Protection

1. Personal Protective Equipment

1.1 What is definition of Person Protective Equipment

PPE is protective clothing, helmet, goggles or other garments or equipment design to protect the body from injury or infection. The hazard addressed by protective equipment include physical, electrical, heat, chemicals, biohazard.

1.2 List out all compulsory PPE required to be worn while perform job offshore

- Helmet ✓
- Safety Glasses ✓
- Safety Shoes ✓
- Coverall ✓

1.3 List the area where the PPE should be worn while working

- Production Area (offshore) ✓
- Workshop (onshore) ✓
- Red Zone ✓
- Rig ✓

1.4 List the PPE should be worn while doing maintenance at tools and equipment

- Helmet ✓
- Safety glasses ✓
- Safety Shoes ✓
- Coverall ✓
- Impact glove ✓
- back Support ✓

1.5 PPE should you wear while working in mercury and H₂S are

- must use Personal H₂S monitor set to alarm at 10ppm.
- Emergency life Support Apparatus (ELSA)
- Full face Respirator

Alleynson
ALLEYSON AKIN
DIMENSION BID (M) SDN BHD
East Malaysia Operation

1.



5/1
copy

2. Responsibility

2.1 Employee Responsibilities towards Health, Safety and Environmental (HSE)

Prevent and ~~eliminate~~ injury and illness to employees and assist companies to comply with safety laws. They inspect workplace and minimize or eliminate hazard from process such as incorrect working methods and material such as potential toxic chemicals.

2.2 What are the safety precautions to be taken during tool maintenance at warehouse?

- provide training and course, clearly label designated hazardous zones; promote awareness in warehouse

2.3 When should we do housekeeping?

After complete the task / job, keep the hand tool and equipment from where it been taken, switch off all electrical equipment before leaving work area. Clean / mopping slippery floor.

2.4 Why housekeeping is important?

- To keeping and maintain workplace in safe area
- Reduce property damage by improving preventive maintenance

2.5 How should you react while seeing somebody committing into unsafe act/behavior?

- Intervene / report or stop work.

ACT / ~~WAT~~ UCLX

Alleyson
ALLEYSON AKIN
DIMENSION BID (M) SDN
East Malaysia Office



Perceived

3. Policies

3.1 List down all DB policies in regards to HSE

Driving policy, HSE policy, PPE policy, Stop-work policy, Information Technology policy,
Drug and alcohol policy, Harassment in the work place policy, Smoking and
Vaping policy.

3.2 What is HSE Policies

The HEALTH SAFETY and Environment (HSE) Policy embodies the philosophy
and commitment of the company toward environmental protection and management
at health and safety of employees, contract work man and visitor,
environmental protection we shall ensure sustainable resources usage.

3.3 What is the purpose of 'STOP WORK' policy?

Stop work policy is a program designed to provide employees and
contract workers with the responsibility and obligation to 'stop work'
when a unsafe condition or behavior may result in an unwanted
event.

Alleynson
ALLEYSON AKIN
DIMENSION BID (M) SDN BHD
East Malaysia Operation





4 Hazard ID and Incident Reporting

4.1 How can we report hazard or unsafe act?

Please donot wait for someone else to report a hazard. Let someone know right away so that it can be addressed before someone is injured. If you believe that an unsafe working condition exists in the work place you have the right and are encouraged to make a report at the condition.

4.2 If there is an incident happened at workplace what should we do?

- Have a plan in place and share it all type of workplace incident report form don't delay unnecessarily.
- Eliminate the injury - tend the injury before first aid
- Visit the doctor
- check in with your employer

4.3 What is the incident reporting process?

Incident reporting and investigation procedure on incident is an unplanned occurrence that result or could result in injury to people or damage to property. An incident may also be considered an accident or near miss.

4.4 What is the purpose of Hazard Hunt? And how does that help to be safe?

By reducing the risk that you can identify using the hazard hunting programme you make your workplace safe. This will help you prevent incident. Hazard hunting is suitable for everyone who work at an onshore or offshore / office.

4.5 Please explain what is Near Miss

Near miss is an unplanned event that has the potential to cause loss, but does not actually result in human injury, environment or equipment damage or an interruption to normal operation.

4.6 In case of emergency,

a) Firstly what should you do?

Report to ASE or shout for help.

b) Where is DB assembly point (Base)?

outside main gate / car park.

Meyer
ALLEYSON AKIN
DIMENSION BID (M) SDN BHD
East Malaysia Operation



4.7 Where can you find the emergency contact Number?

- Meeting room
- management office

5. Operational Safety

5.1 How to prevent an accident before executing certain job or activities

keep work place clean, housekeeping after complete jobs/task,
provide proper training

5.2 What is the purpose of Safety Morning Meeting

Safety morning meeting to communicate any safety idea or concern that you may have participate in your safety meeting.

5.3 What is the purpose of briefing and Debriefing

Briefing provide the information needed to direct deployed resources. This information is also used for debriefing personnel in order to obtain further relevant available information.

5.4 What is Permit To Work (PTW)

PTW refer to management system used to ensure that work is done safely and efficiently. These are used in hazardous activities and involve procedures to request, review, authorize, document and most importantly, de-conflict tasks to be carried out by front line workers.

5.5 Explain what do you understand from Job Safety Analysis and how does this help you to be safe?

In JSA, each basic step of job is to identify potential hazard and to recommend the safest way to do job. JSA are not suitable for jobs defined to broadly for example overloading engine or to narrow for example positioning car jack.

5.6 What are the safety precautions to be taken during tool maintenance at warehouse?

Clearly label designated hazardous zones, always use correct lifting technique, provide training and refresher course, provide awareness in warehouse

Alleyn Akin
ALLEYSON AKIN
DIMENSION BID (M) SDN BHD
East Malaysia Operation



5.7 What are the safety precautions to be taken during topping up the fuel into Power Pack Tank?

Use rubber glove and face mask

5.8 What is work permit & why do we need them?

PTW is the document that serve as authorization to do specific work at given location on specific time. PTW is use of non-routine jobs

5.9 When do we apply the work permit

when we are going to do routine / non-routine jobs

5.10 What are the safety precautions to be taken during test lubricator and BOP?

Briefing / Safety meeting, hose in good condition, install whip check, ensure all connection is tight.

5.11 What are the safety precautions to be taken during test Control Panel?

ENSURE all tubing with no leak, ensure whip check installed at all CP hose, out CP at suitable place for testing activity.

5.12 Why JSA, Risk Assessment and Job Plan need to be discussed among the team member? How does that work?

to ensure the team member aware at the activity procedure and its risk. Team members that is aware of the risk will work according to correct procedure and to avoid discussed risk.

5.13 While working, you found that there is something unsafe. What should you do?

Stop work, assess the risk and apply correct measure, stop work if not safe to continue the task / jobs.



5.14 Before performing a hot work, what must you do/ have to ensure the work is safe

Site visit, Apply PTW, Conduct tool box meeting before start the task.

Alleyson

ALLEYSON AKIN
DIMENSION BID (M) SDN BHD
East Malaysia Operations

Others

1. Please attach the supporting documents that you participated in Dimension Bid's Safety program.
 - a) Job Safety Analysis for each activity that you involve during probation period
 - Chipping
 - Painting
 - Lifting
 - Spooling
 - Pressure Test
 - b) Hazard Hunt
 - c) Safety Talk

B. SURFACE EQUIPMENT

1. Stuffing Box

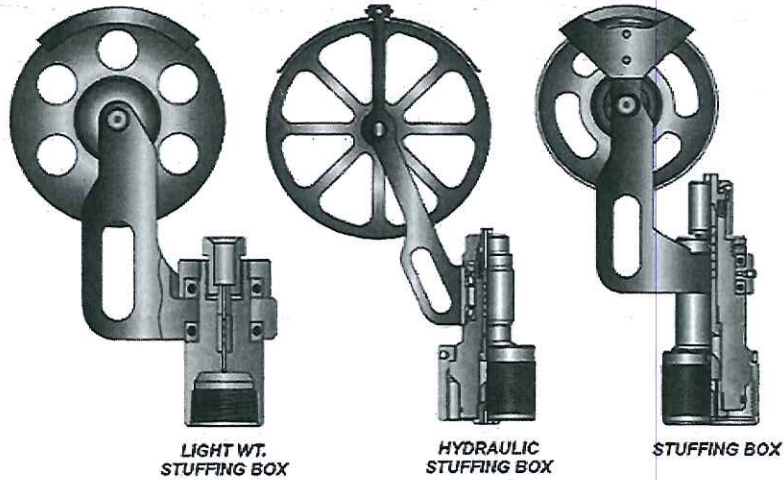

What is Stuffing Box

stuffing box is specifically designed to seal around solid wireline (sliceline) to confine wellbore fluids and gases within the surface pressure equipment (PCE)

What is the purpose of stuffing Box

function of stuffing box is to seal around the wire at the upper end of the lubricator during sliceline operations in both static and dynamic conditions.

How to operate Stuffing Box

The stuffing box can be operated either manually or hydraulically without part modification.

What is maintenance required for Stuffing Box

- Change the upper and lower brass packing gland if worn oversize.
- Change the packing if worn outside of the gland (10" x 10" (254mm x 254mm))

What is safety precaution required for Stuffing Box

- Don't use if Bop plunger worn out / not suitable for size wire.
- proper handling



What is potential hazard during handling Stuffing Box

- Pinch point.
- Back pain.

Draw & name each part of stuffing box

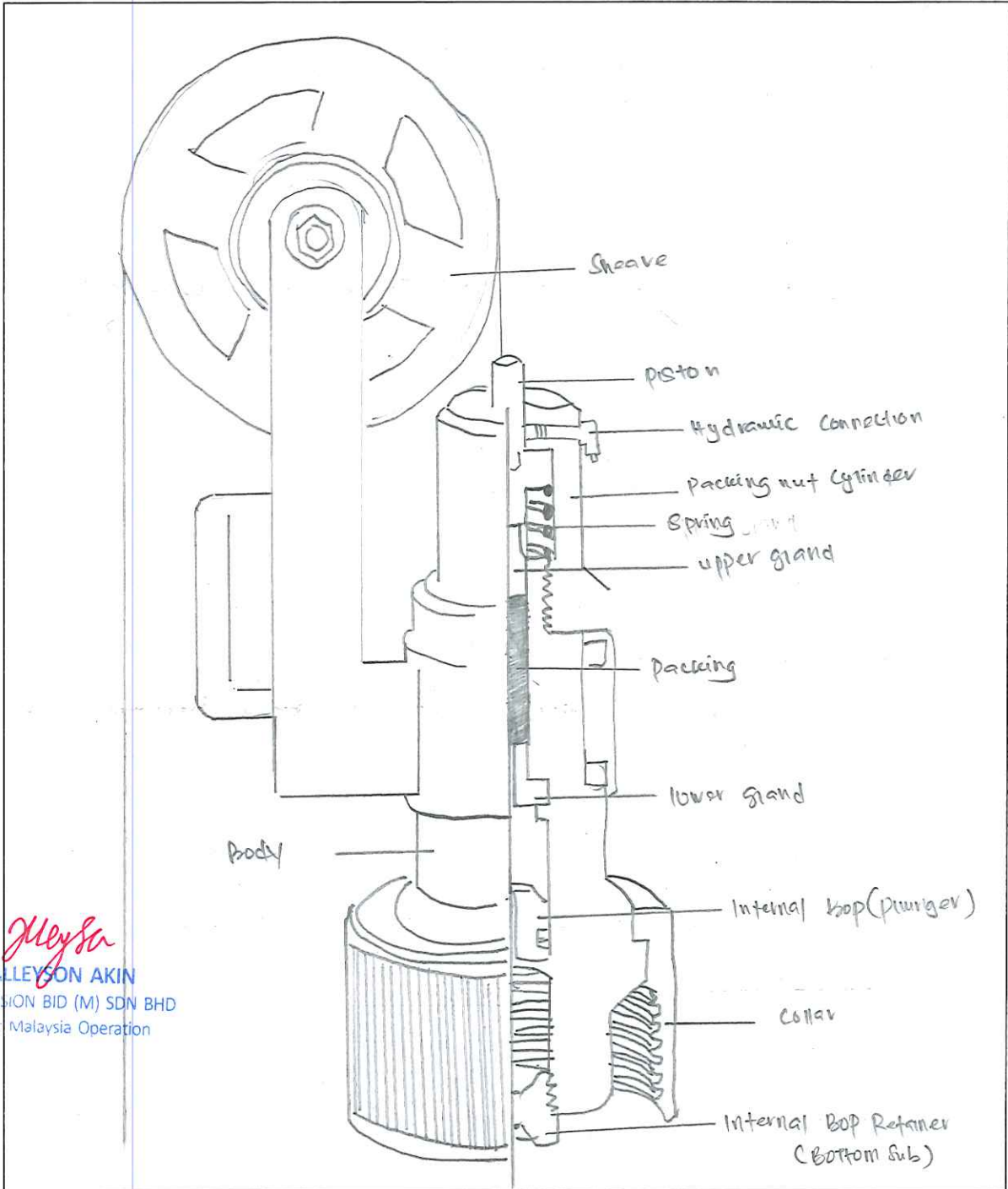

Meyson

ALLEYSON AKIN
DIMENSION BID (M) SDN BHD
Malaysia Operation



2. Lubricator

What is Lubricator

Lubricator a long, high pressure pipe fitted to the top of a wellhead or X-mass tree, wireline tool may be put into a high pressure well.

What is the purpose of Lubricator

To accommodate downhole wireline toolstring while rigging up and during wireline operation, as well as when entering the wellbore returning to surface.

How to operate Lubricator

Using chain block make sure lubricator in straight position before it connected.

What is maintenance required for Lubricator

Pressure test, painting, API test

What is safety precaution required for Lubricator

Bleed off pressure in lubricator until zero before breakoff lubricator connection.

What is potential hazard during handling Lubricator

- Back pain ✓
- Pinch point ✓
- Slip and fall ✓



Draw & name each part of Lubricator

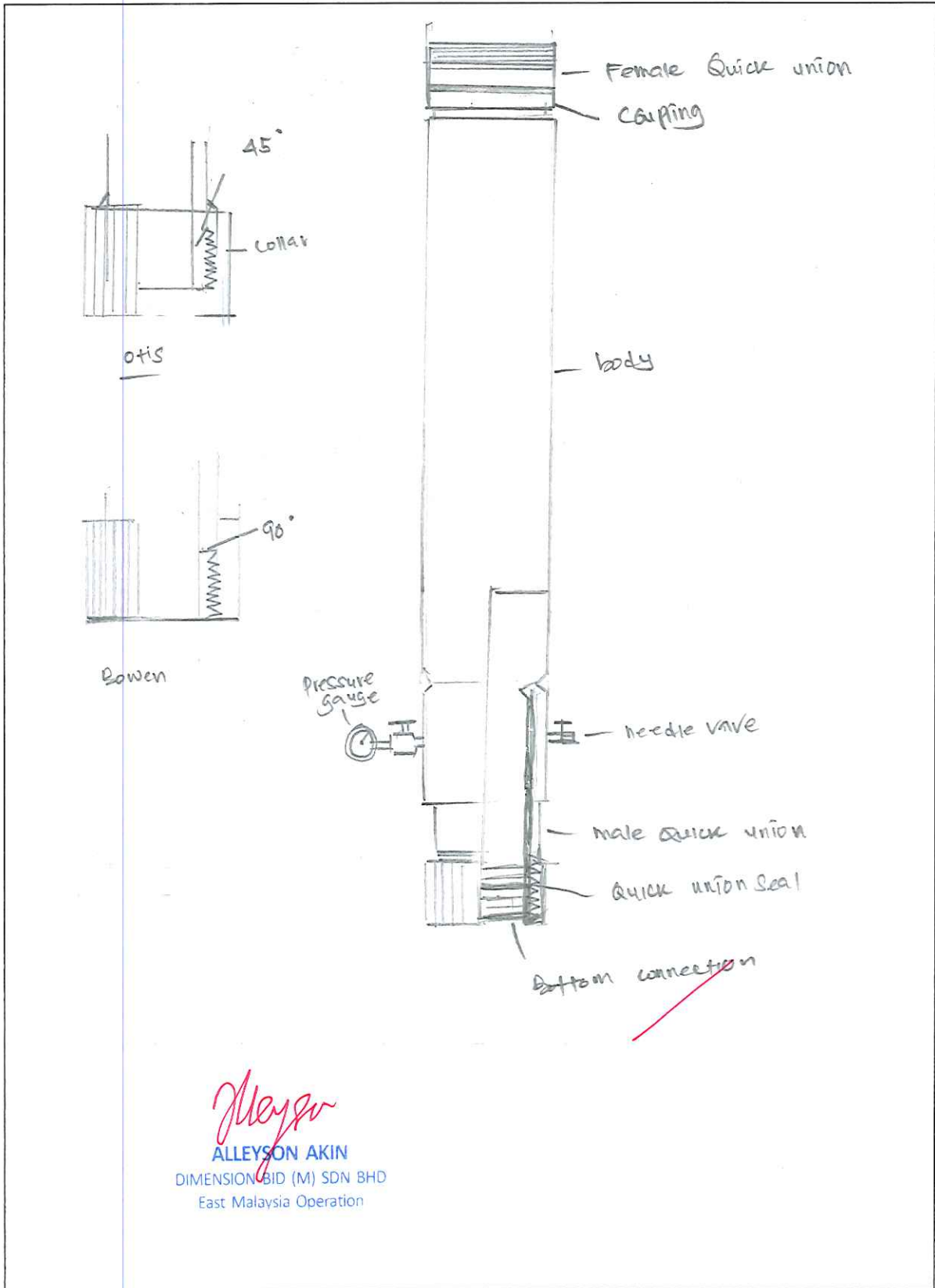

Alleyson

ALLEYSON AKIN
DIMENSION BID (M) SDN BHD
East Malaysia Operation





3. Blowout Preventer (BOP)

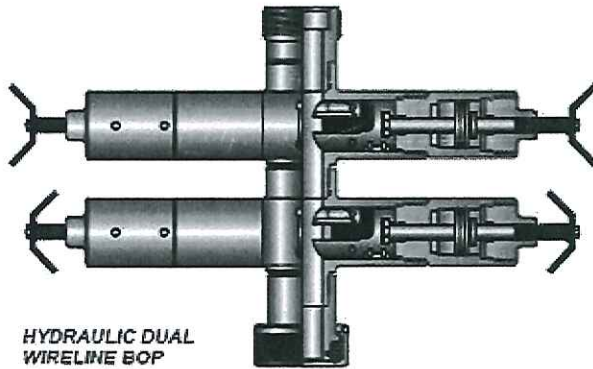

HYDRAULIC DUAL WIRELINE BOP

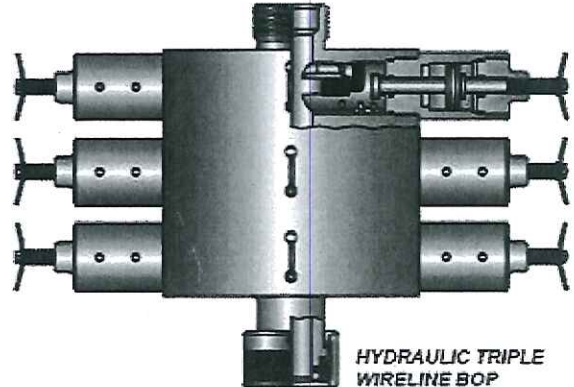

HYDRAULIC TRIPLE WIRELINE BOP

What is BOP

- BOP is a large, specialised valve or similar mechanical device. They are usually installed in stack of other valve or PCE.
- Secondary barrier.

What is the purpose of BOP

used to seal, control and monitor oil and gas wells to prevent blowout, the uncontrolled release of crude oil and or natural gas from well

How to operate BOP

- Use control panel to open and close upper ram and lower ram. (Hydraulic)
- Hydraulic force is applied to close ram which seal around the wire.

What is maintenance required for BOP

- Change new O-ring
- Change new liner seal if worn out.
- Grease the thread

What is safety precaution required for BOP

- The Rams operating handle are of prime importance during an emergency. Never rig up a BOP without the handle installed.
- Have maximum working pressure, Do not use if above maximum working pressure.



What is potential hazard during handling BOP

- Pinch point ✓
- Edge point ✓

Draw & name each part of BOP

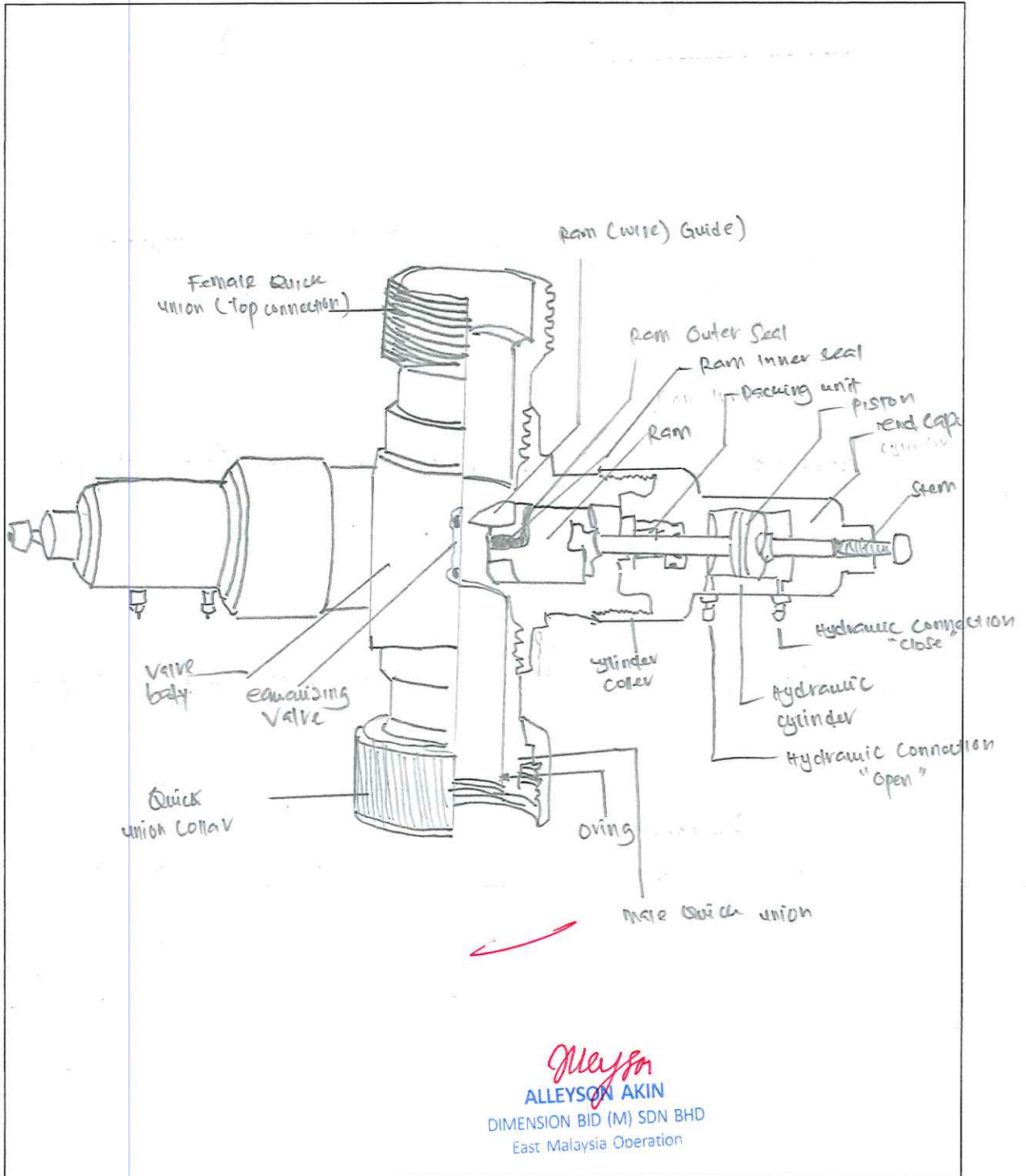



4. X-Mas Tree

What is x-mas tree

X-mas tree is a series of valve installed on the wellhead to control the flow of fluid from the well/reservoir.

What is the purpose of x-mas tree

Pressure monitoring, seal pressure, control the flow of well

How to operate x-mas tree

Single Well Control panel (SWCP) ↓ Well Control panel (CWP)

What is maintenance required for x-mas tree

Test of valve, preventive maintenance (PM) ↓ Corrosion maintenance (CM)

What is safety precaution required for x-mas tree

Always count the turn of valve during close and open to prevent over torque.

What is potential hazard during handling x-mas tree

Pinch point, back pain, slip and fall



Draw & name each part of x-mas tree

Lucas

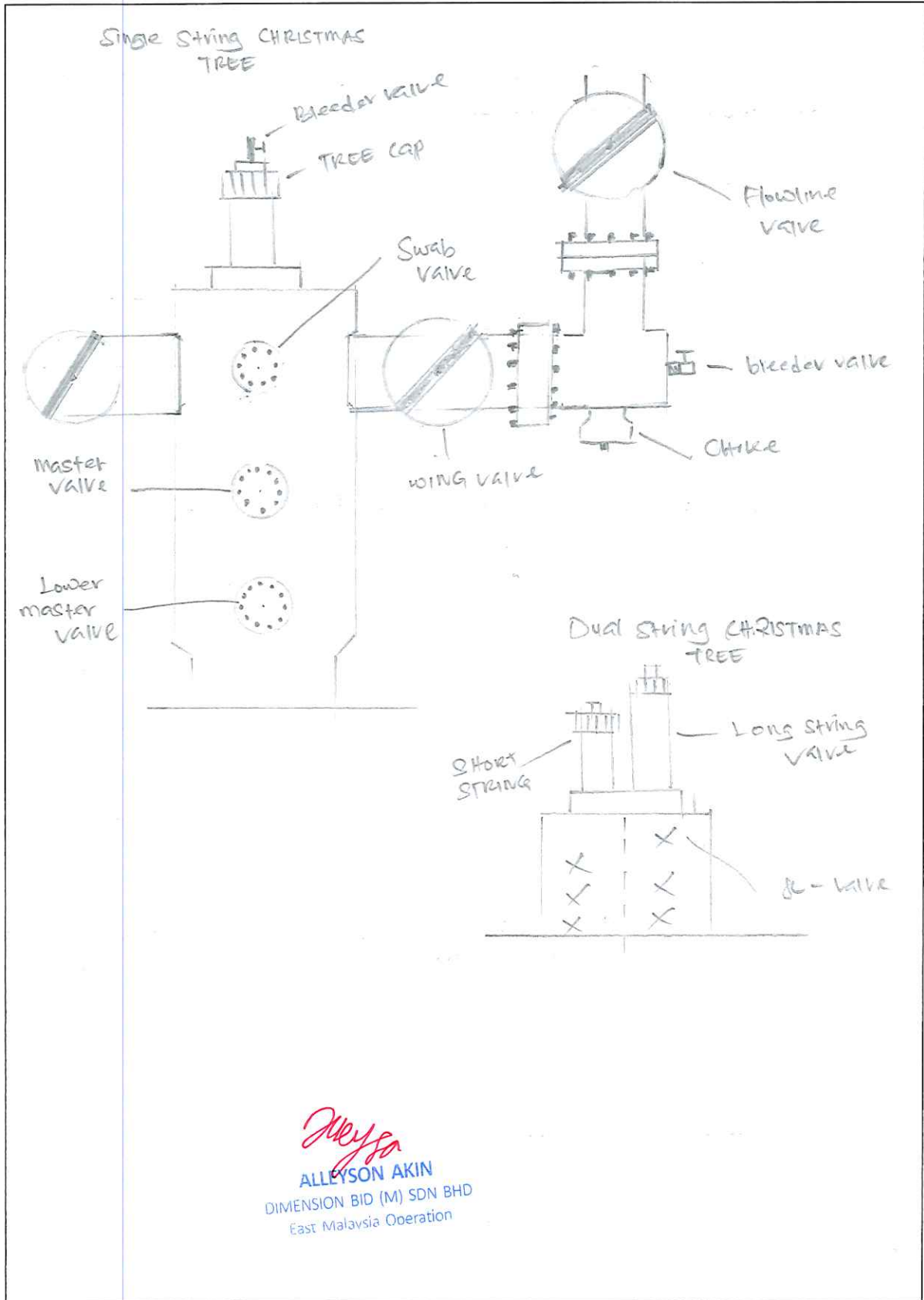

Alleyn
ALLEYSON AKIN
DIMENSION BID (M) SDN BHD
East Malaysia Operation



5. Wireline Reel Skid Unit (RSU) / Winch – Single Drum and Double Drum

What is RSU

A unit that have a drum that contain wire and a panel to control the drum direction and speed.

What is the purpose of RSU

Contain a drum which have a wire to lower down our tool and pull the well accessories.

How to operate RSU

By power pack (Hydraulic pressure), There is also a valve to control the hydraulic pressure.

What is maintenance required for RSU

Hydraulic filter, check hose connection, odometer cable condition.

What is safety precaution required for RSU

- Double check hose condition from power pack to RSU before operate.
- Check condition wire at drum.

What is potential hazard during handling RSU

Hose burst, wire break, pinch point.



Draw & name each part of RSU

Tempat

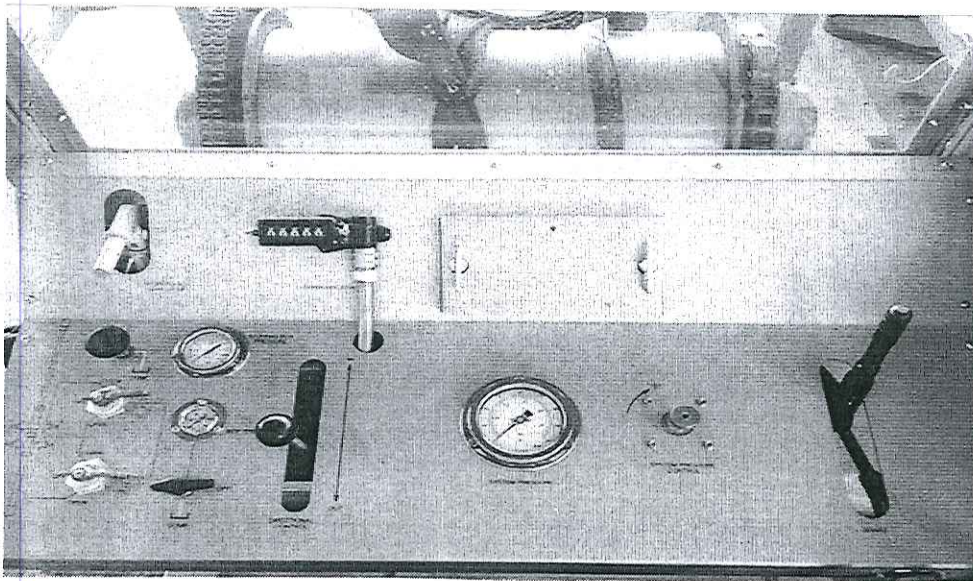

Meysa
MEYSON AKIN
DIMENSION BID (M) SDN BHD
Operation



6. Odometer

What is Odometer

Odometer is a device that record and show the current depth of our tool.

What is the purpose of Odometer

Show the current depth of tool during running and pulling.

How to operate Odometer

connect the odometer to the one annulus of measuring wheel (RS4) with odometer cable. The odometer have the ratio 1:2.

What is maintenance required for Odometer

Clean the cable with WD-40, spray the knob with WD-40.

What is safety precaution required for Odometer

Use slow while turning the the knob.

What is potential hazard during handling Odometer

Bunch point, sharp edge



Draw & name each part of Odometer

luis

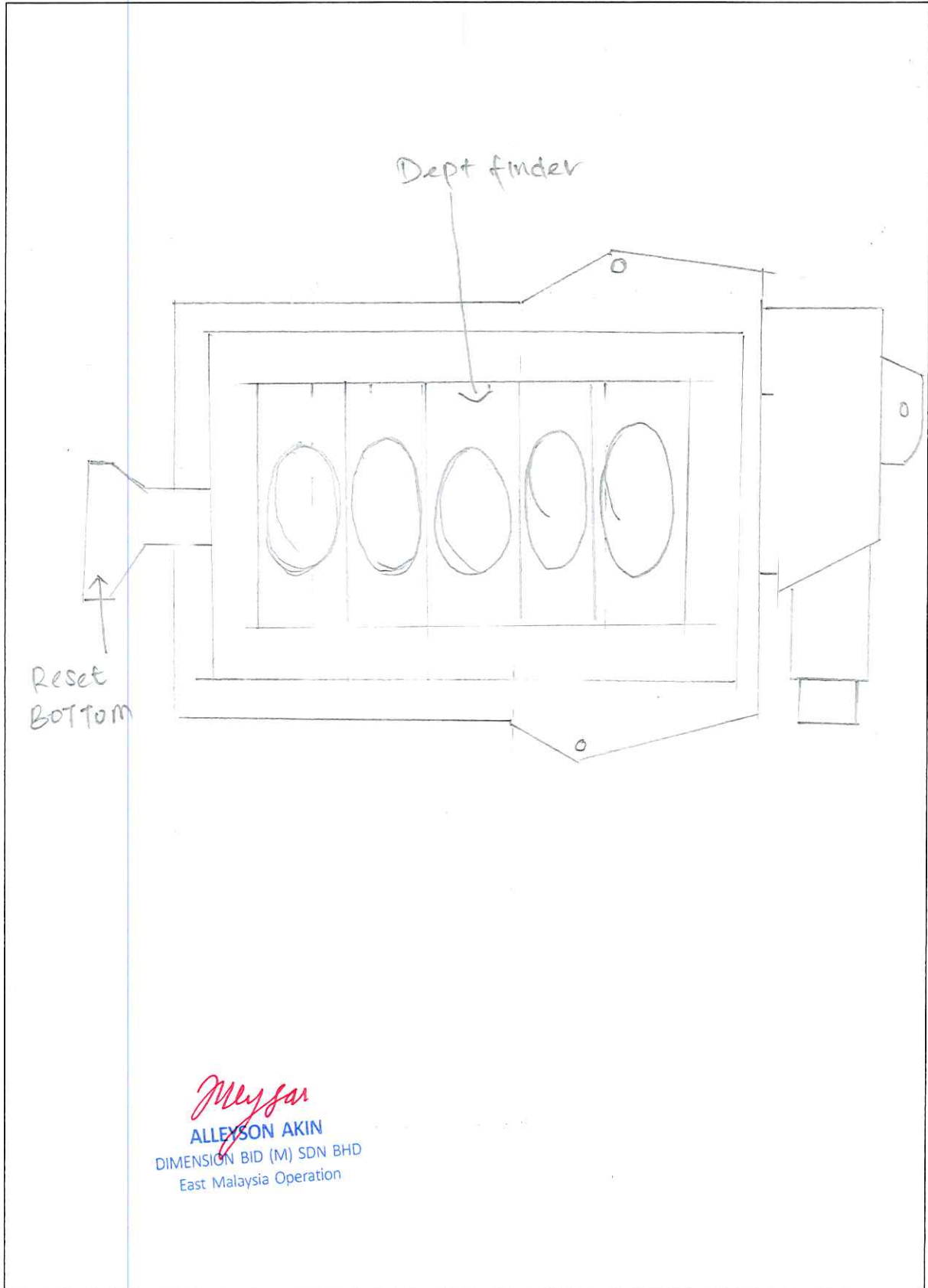

Meyzar
ALLEYSON AKIN
DIMENSION BID (M) SDN BHD
East Malaysia Operation



7. Weight indicator (200 lbs and 4000 lbs)

What is Weight Indicator

A device or system used to measure or to indicate tool weight during running and pulling wireline tool.

What is the purpose of Weight Indicator

To give action, position of the downhole, Guide wire.

How to operate Weight Indicator

Anchor with line at suitable place / use martin decker fluid.

What is maintenance required for Weight Indicator

calibration, change new hose martin decker

What is safety precaution required for Weight Indicator

make sure hose weight indicator in good condition before use, weight indicator is heavy lift with precaution.

What is potential hazard during handling Weight Indicator

pinch point, sling/chain break off, back pain.



Draw & name each part of Weight Indicator

Lucis

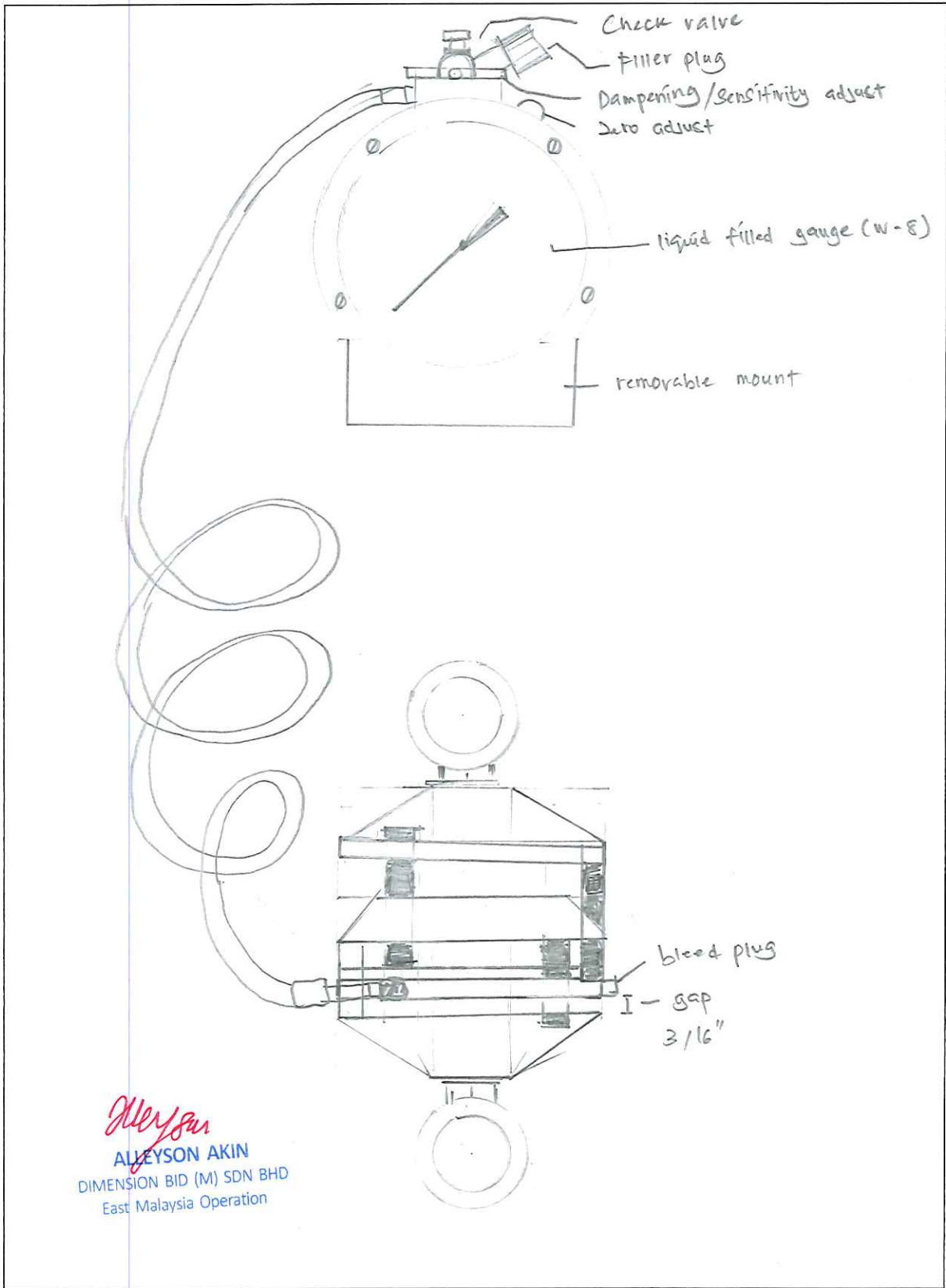

Alleyson
ALLEYSON AKIN
DIMENSION BID (M) SDN BHD
East Malaysia Operation



8. Spooling Device

What is Spooling Device

A device that hold the reel during Spooling process.

What is the purpose of Spooling Device

To hold the reel in Spooling process. It also give proper tension during Spool around 200 lbs.

How to operate Spooling Device

Assemble the reel. The setup is almost the same with normal operation which weight indicator and way pulley is needed. Spooling device have a brake lever and that will help to control speed and give tension.

What is maintenance required for Spooling Device

Brake maintenance, paint body Spooling device

What is safety precaution required for Spooling Device

Ensure Drum in good condition (belt and nut), no leak.

What is potential hazard during handling Spooling Device

Dive parted, pinch point



Draw & name each part of Spooling Device

tampal

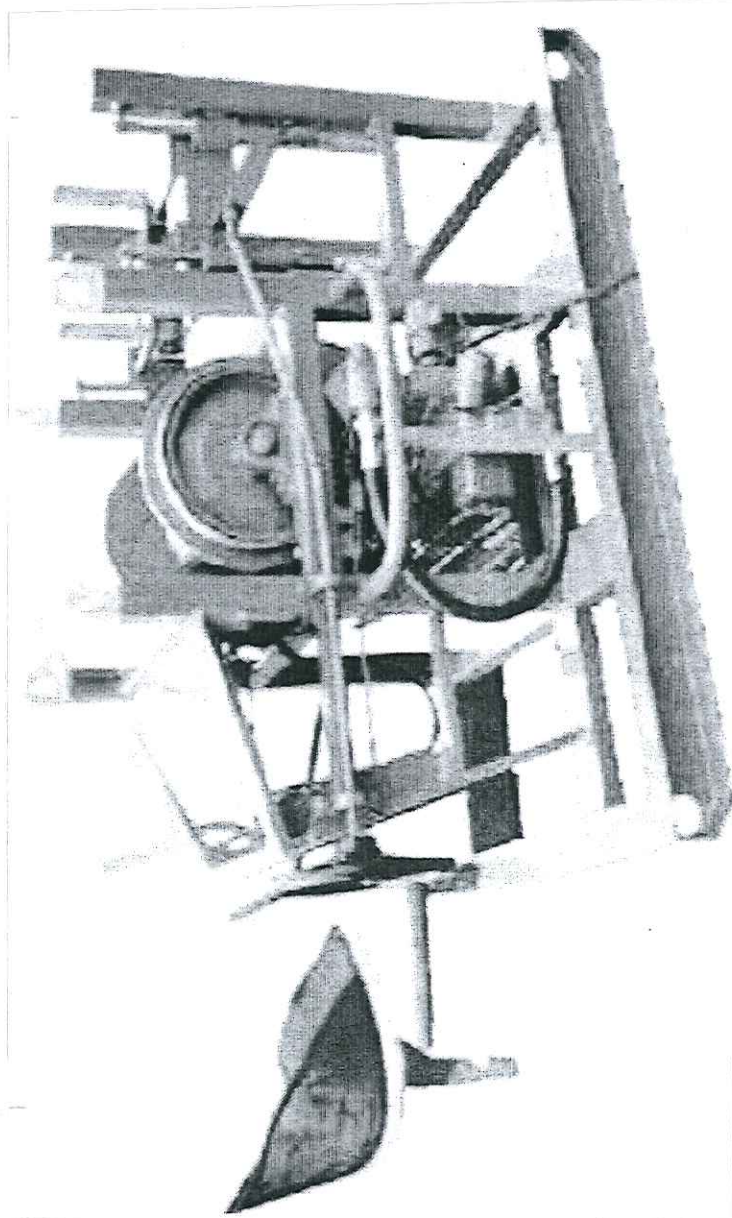

Meysa
East Malaysia Operation
DIMENSION BID (M) SDN BHD
ALLEYSON AKIN



9. Control Panel

What is Control Panel

Control panel series of pump and gauges that use to control our equipment and the well head (x-mas tree)

What is the purpose of Control Panel

To open and close flapper B7 / IRSESEV and SOV.

How to operate Control Panel

Connect the control line to the equipment. Open air supply use the regulator to control pump and pressurize the line

What is maintenance required for Control Panel

- Hydraulic Oil (use correct hydraulic grade)
- Change new control line/hose if damage/leak
- Regulator
- Ensure no leak at control panel line.

What is safety precaution required for Control Panel

Ensure all connection is secured use whip check, ensure no leak.

What is potential hazard during handling Control Panel

Hose burst, stuck by equipment during fitting, pinch point, blow pain.

Draw & name each part of Control Panel

hampai ✓

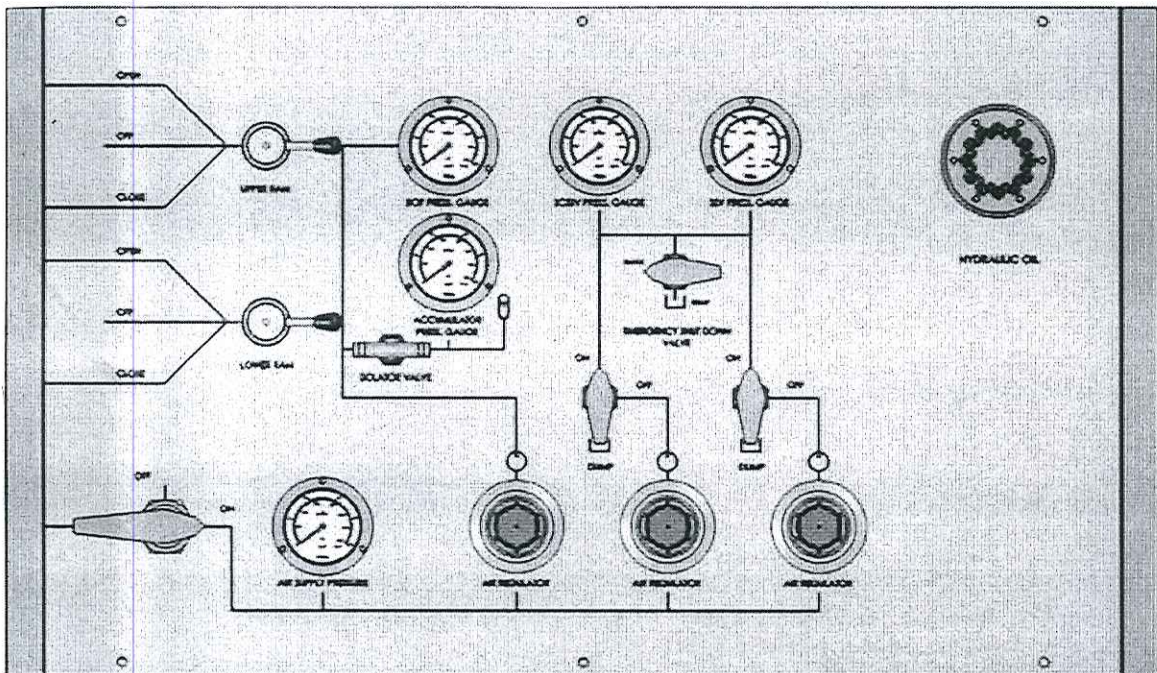
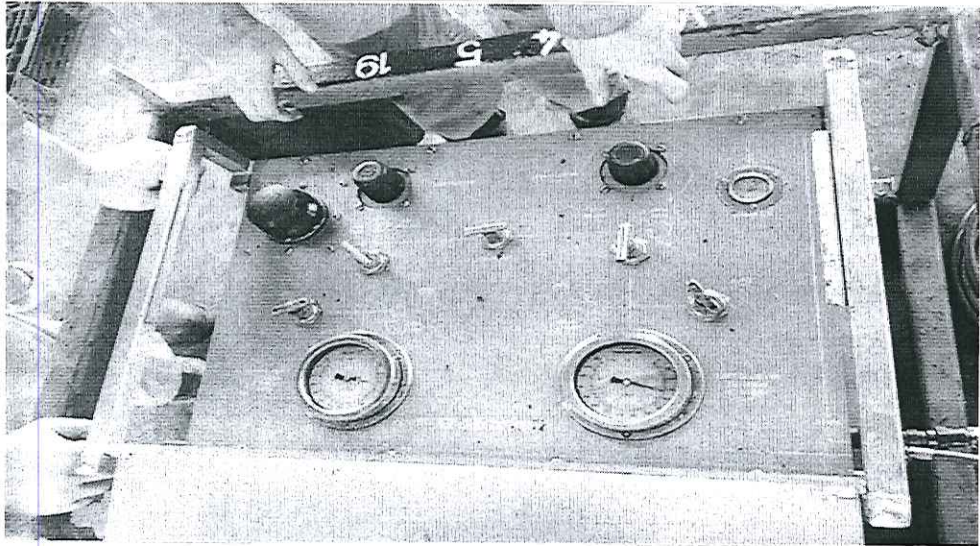

Meysan
ALLEYSON AKIN
DIMENSION BID (M) SDN BHD
East Malaysia Operation



Draw & name each part of Huskel Drum

Handwritten: Huskel ✓

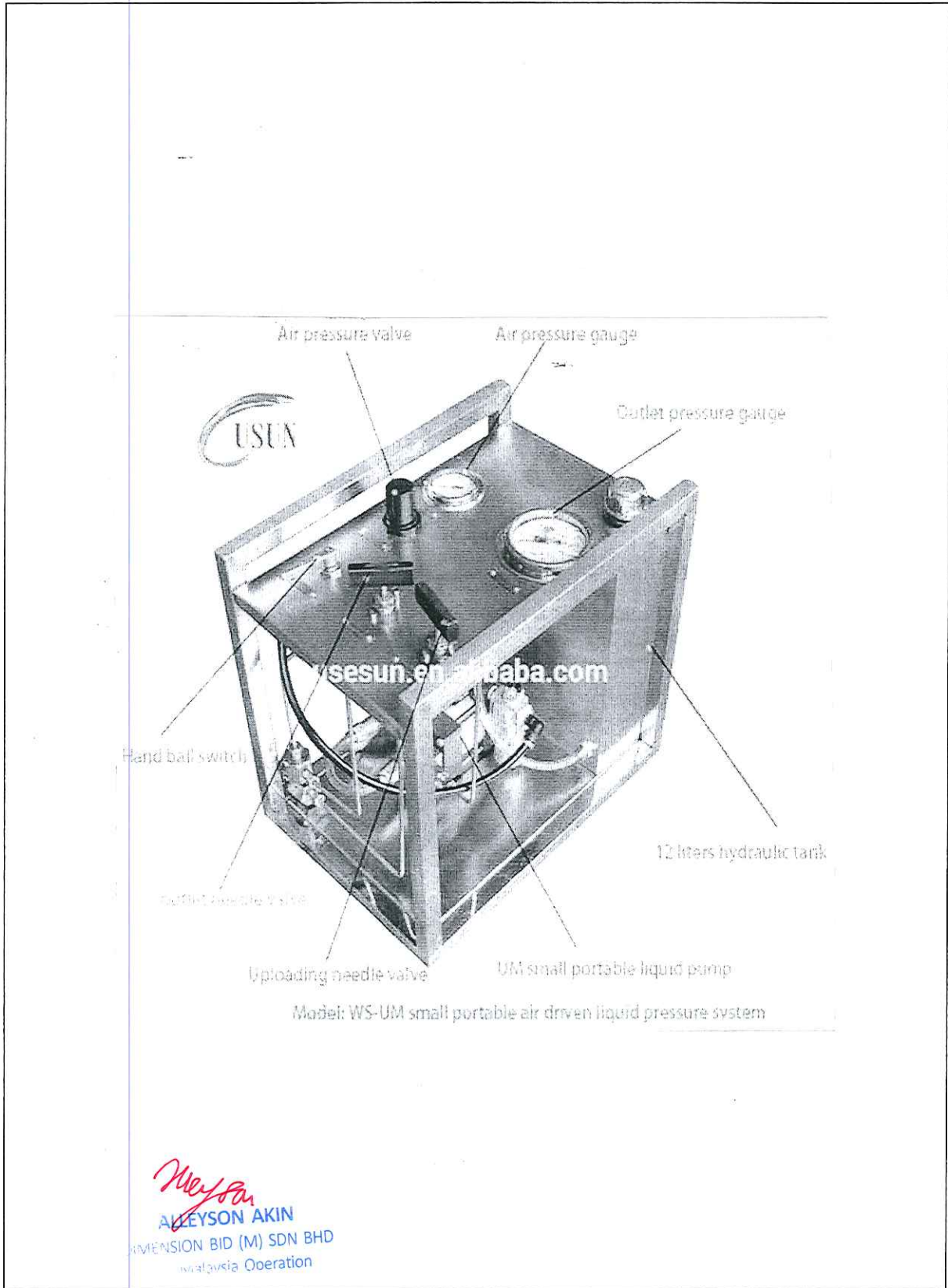



11. Power Pack (Electrical & Diesel)

What is Power Pack

machine that consist of electric motor or diesel engine that use to drive hydraulic pump for RS4 operation or ~~wireline mast~~.

What is the purpose of Power Pack

To provide and supply the hydraulic ~~power~~ to RS4 and ~~wireline mast~~

How to operate Power Pack

make sure pump hydraulic until ~~2000 psi~~ and above, push Inlate valve & air valve then push the start paddle. Do not release Inlate & air valve until oil pressure reach above and stay around 60-80.

What is maintenance required for Power Pack

always check coolant water before start operation, clean flame trap, check oil filter.

What is safety precaution required for Power Pack

Guard cover on pp, ~~ensure~~ all hose install whip check

What is potential hazard during handling Power Pack

under pressure, hot surface, ~~rotating~~ equipment.



Draw & name each part of Power Pack

Handwritten: Hampel ✓

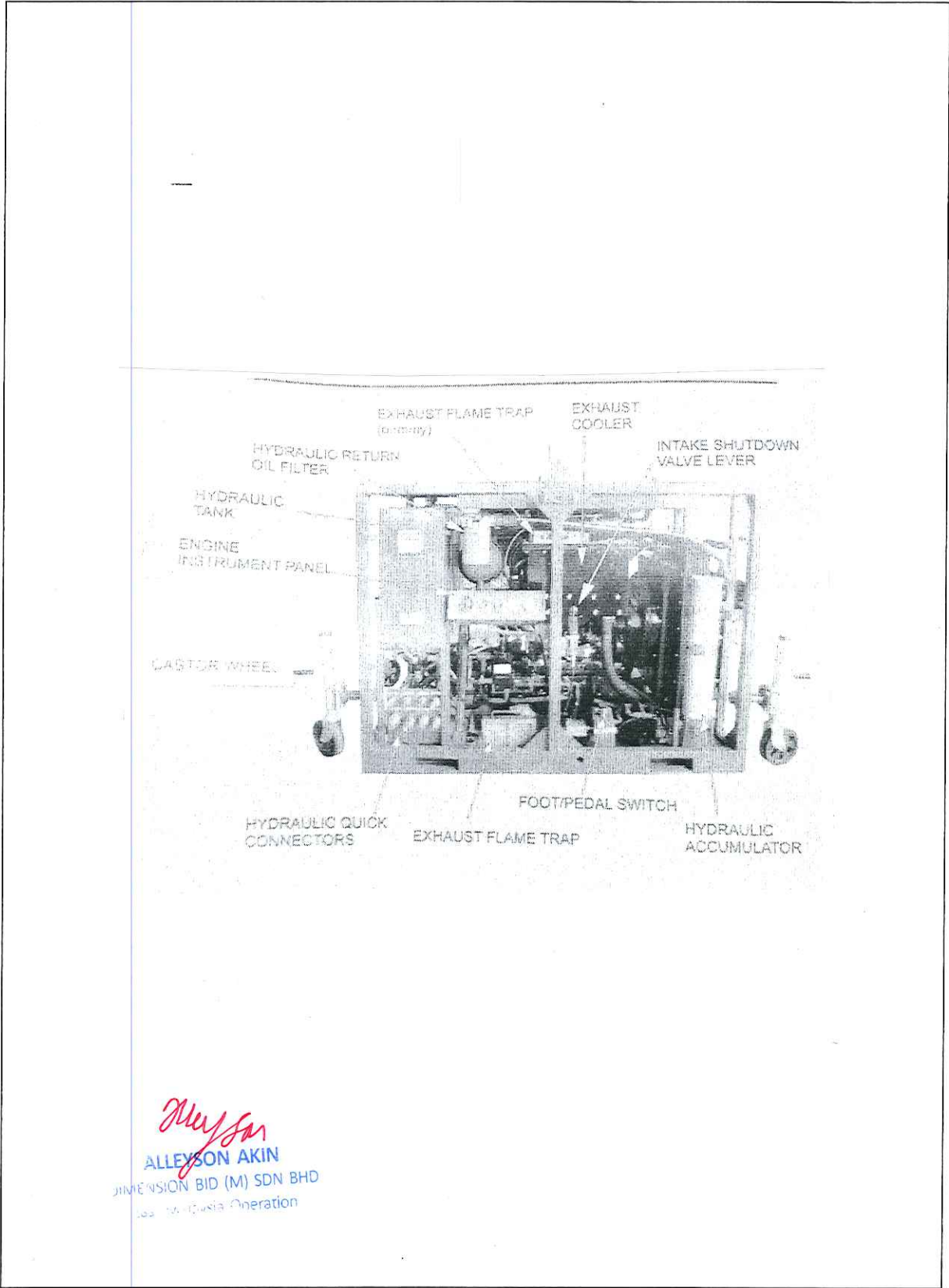

Handwritten signature: Allyson Akin
ALLEYSON AKIN
 DIMENSION BID (M) SDN BHD
 Well Intervention Operation



12. Air Compressor

What is Air Compressor

A machine that have a compressor driven by diesel engine.

What is the purpose of Air Compressor

Supply air to control panel, test pump and air starter engine

How to operate Air Compressor

The starting procedure is almost the same with power pack. The air compressor usually use the the spring starter. To crank the starter, rotate the shaft clockwise until indicator turn red. Release the spring to start.

What is maintenance required for Air Compressor

Check fan belt tension, check bleed valve, bleed water from diesel tank
Change compressor oil, change filter.

What is safety precaution required for Air Compressor

- Ensure safety valve is working
- Ensure engine overspeed functioning -

What is potential hazard during handling Air Compressor

Hose burst, pinch point, rotating equipment, hot surface.



tampel ✓

Draw & name each part of Air Compressor



Alleyn
ALLEYSON AKIN
DIMENSION BID (M) SDN BHD
Malaysia Operation



13. Drum

What is the purpose of Drum

for store wire

Do the right and wrong wire arrangement from drum to hay pulley

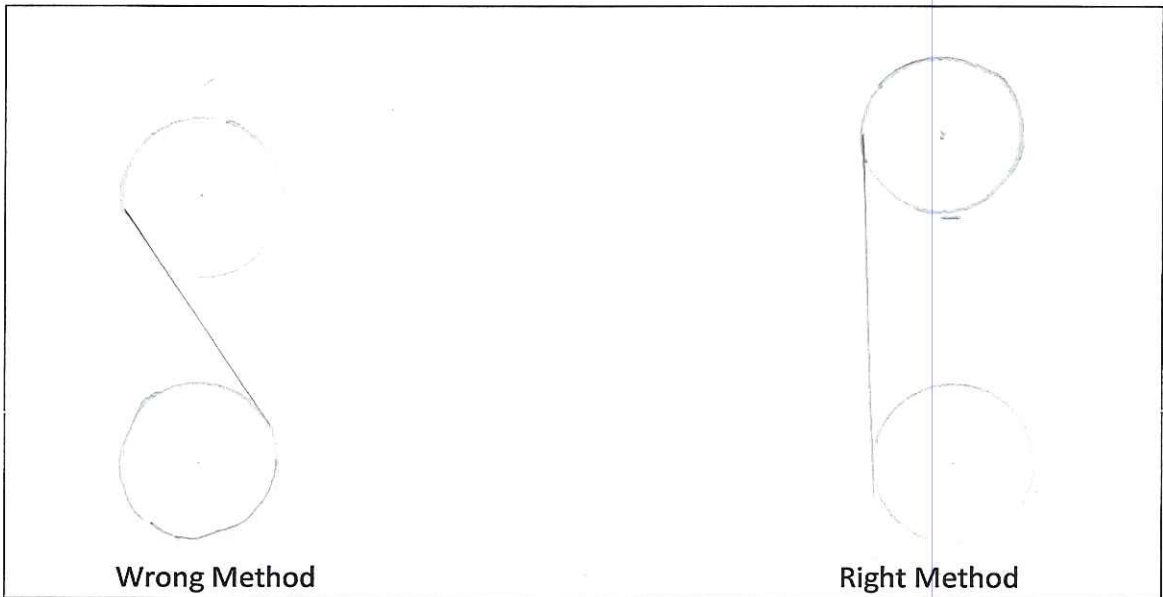

Wrong Method

Right Method

What is maintenance required for Drum

- Grease bearing
- Painting and Chipping rust at drum

What is safety precaution required for Drum

Ensure pillow bearing is fitted properly.

What is potential hazard during handling Drum

wire break, pinch point, back pain.

Alleyn Akin
ALLEYSON AKIN
DIMENSION BID (M) SDN BHD
East Malaysia Operation



- i) gauge cutter,
 To check the tubing ID, To tag the total depth, To locate the nipple ID and no-gas. To locate restrictions, To cut sand, scale, paraffin, To determine the profile of a bridge (Run successively the smallest cutters and plot the depth versus the size to establish the shape of restriction.)
- j) Blind Box
 Used when downward jarring is required to dislodge a fish or push something down the hole.

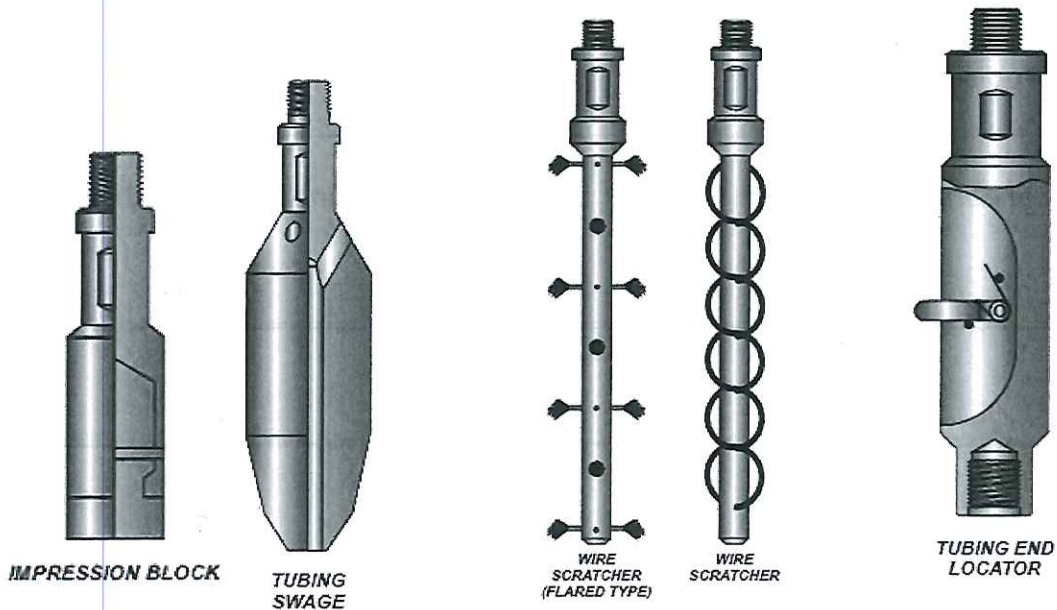

- k) lead impression box
 To obtain a 'picture' of the downhole blockage, the lead is 'keyed' in position by a roll pin or a hex headed bolt.
- l) swage
 For clean minor restriction cause by light collapse in the tubing string
- m) wire scratcher
 To clean tubing and accessories

Alleyn Akin
 ALLEYSON AKIN
 DIMENSION BID (M) SDN BHD
 West Malaysia Operation



n) tubing end locator

- Used to locate the end of the tubing when running the completion as a cross-reference check of the tubing tally.

o) wire recover tool

for fishing wire

Fill up below Table

<p>A. Size of Wire that use at DB</p> <p>1. 0.108" ✓</p> <p>2. 0.125" ✓</p> <p>3. 0.140" ✓</p>	<p>B. Breaking point of each wire</p> <p>1. 2500 lbs ✓</p> <p>2. 3500 lbs ✓</p> <p>3. 4050 lbs ✓</p>
<p>C. Type of wire used at DB</p> <p>1. Zeron ✓</p> <p>2. EIPS ✓</p> <p>3. Carbon Steel ✓</p>	<p>D. How to test if wire is good or not</p> <p>1. wire pull test ✓</p> <p>2. Torsion wire ✓</p> <p>3. wrap test } pull test on surface ✓</p>
<p>E. Why do we need to check on the tools before running in hole (RIH)?</p> <p>- Ensure wireline tool connection not breakoff ✓</p> <p>- Ensure wireline tool ✓</p> <div style="text-align: right;"> <p><i>Alleyson Akin</i> ALLEYSON AKIN DIMENSION BID (M) SDN BHD Malaysia Operation</p> </div>	



Please draw/sketch the toolstring configuration for:

- 1) Drift run/tubing clearance check
- 2) Sinker bar run
- 3) Set and retrieve plug
- 4) Set and retrieve insert valve

1/ Drift Run 1 1/2" (top b7/insert valve)

- Rope socket
- Swivel joint
- Normal stem 5 feet
- Link jar 20 stroke
- Drift 2.867"

- * - Hydraulic jar (used after retrieve b7/insert valve)
- * - used 2.735, 2.302 drift run until HUD.

2/ set and retrieve plug

- Rope socket
- Swivel joint
- Stem 5 FT
- Knuckle joint
- Hydraulic jar
- Link jars
- GC pulling tool

- * - X-Line for set.

2/ Sinker bar run 1 1/4"

- Rope socket
- Swivel joint
- Link jar
- mainary stem / normal stem 5 FT
- sinker bar 420 ballnose.

4/ set and retrieve insert valve

- Rope socket
- Swivel joint
- Normal stem 5 FT
- Link jar 20 stroke
- GC pulling tool.

- * - X-Line for set.

Alleyson
ALLEYSON AKIN
DIMENSION BID (M) SDN BHD
Well Intervention Operation

C. DOWNHOLE EQUIPMENT

1. List out all basic running and pulling tools

No.	Items
1	GS Pulling tool ✓
2	GR ✓
3	GB ✓
4	SS ✓
5	JUC ✓
6	JDC ✓
7	RB ✓
8	RS ✓
9	Kick over tool (OK6)
10	JK ✓
11	GA-2 ✓
12	X-Line ✓
13	R-Line ✓
14	OTIS "X" selective positioning tool (XO) ✓
15	OTIS "B" shifting tool (B-up) ✓
16	Selective Down-shift tool (142 BD or B-down) ✓
17	wire scratcher ✓
18	wireline grab ✓
19	Drift ✓
20	Tubing Swage ✓

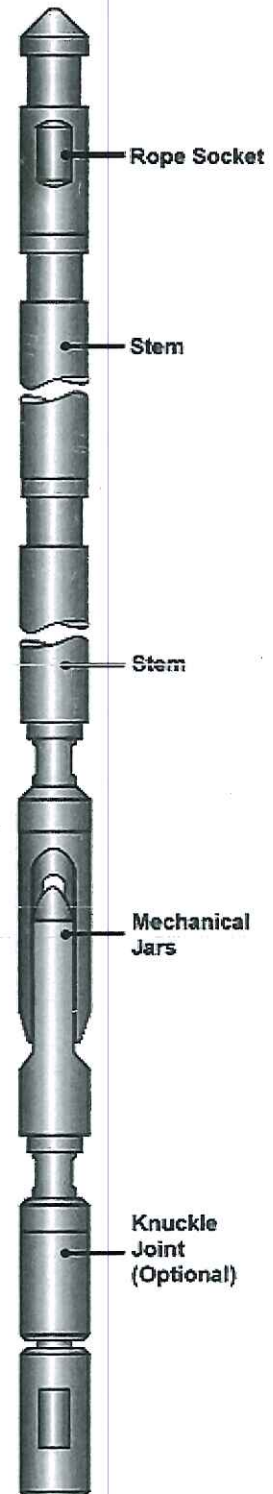

Meysan
 ALLESON AKIN
 DIMENSION BID (M) SDN BHD
 East Malaysia Operation

Primary Wireline Tool-string

Tool-string configuration according to requirement. Introduction to

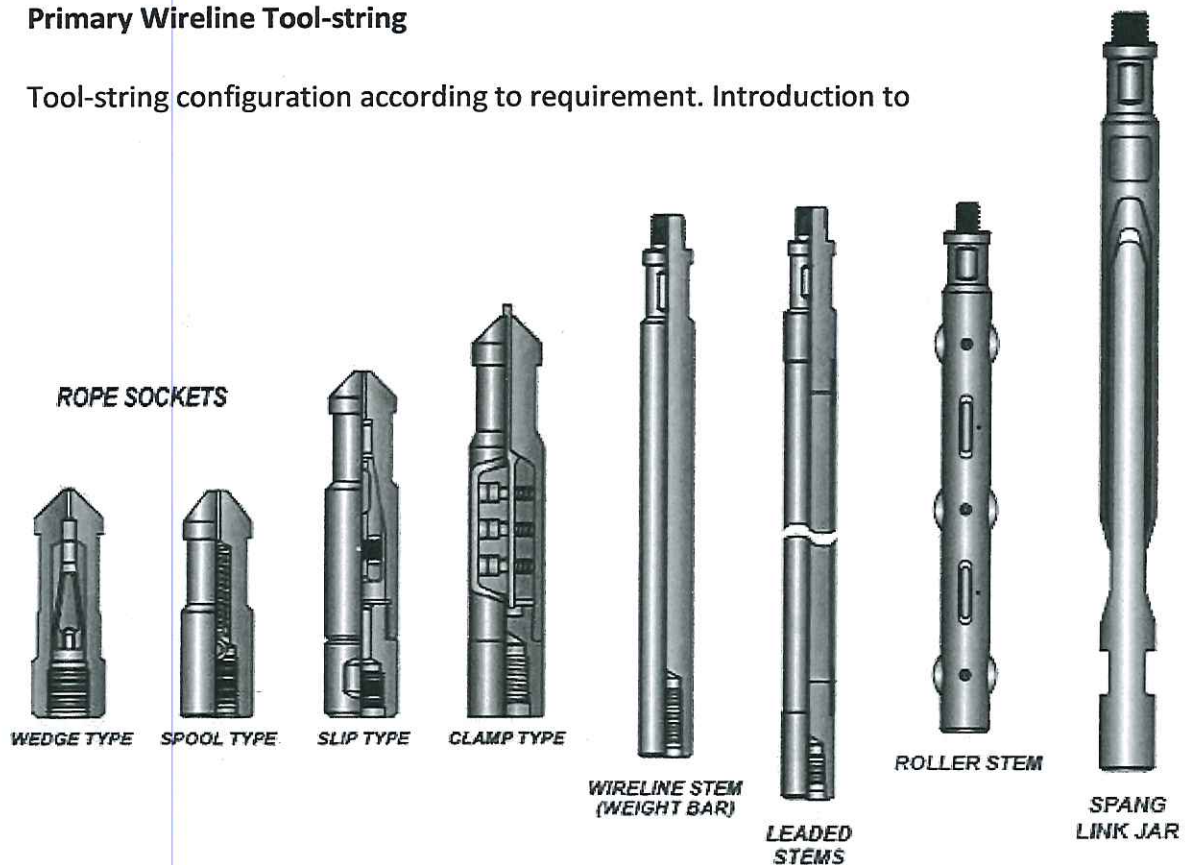

a) rope sockets

The rope socket is required to make the connection between the wireline and toolstring.

b) stem lead

The stem provides weight to the toolstring to enable the wire to run into the well against well pressure and stuffing box friction.

c) tungsten stem

To provide greater weight for the same diameter and length. This stem is used primarily to run flowing pressure survey to obtain maximum weight and maximum cross-sectional area to protect against 'floating' or being blown up.

d) roller stem

The roller stem is valuable, sometimes essential, addition to toolstring for deviated wells to reduce the frictional losses against the tubing wall.



e) jars

Act as a downhole hammer and provide impact force to operate
Set and retrieve / downhole equipment.

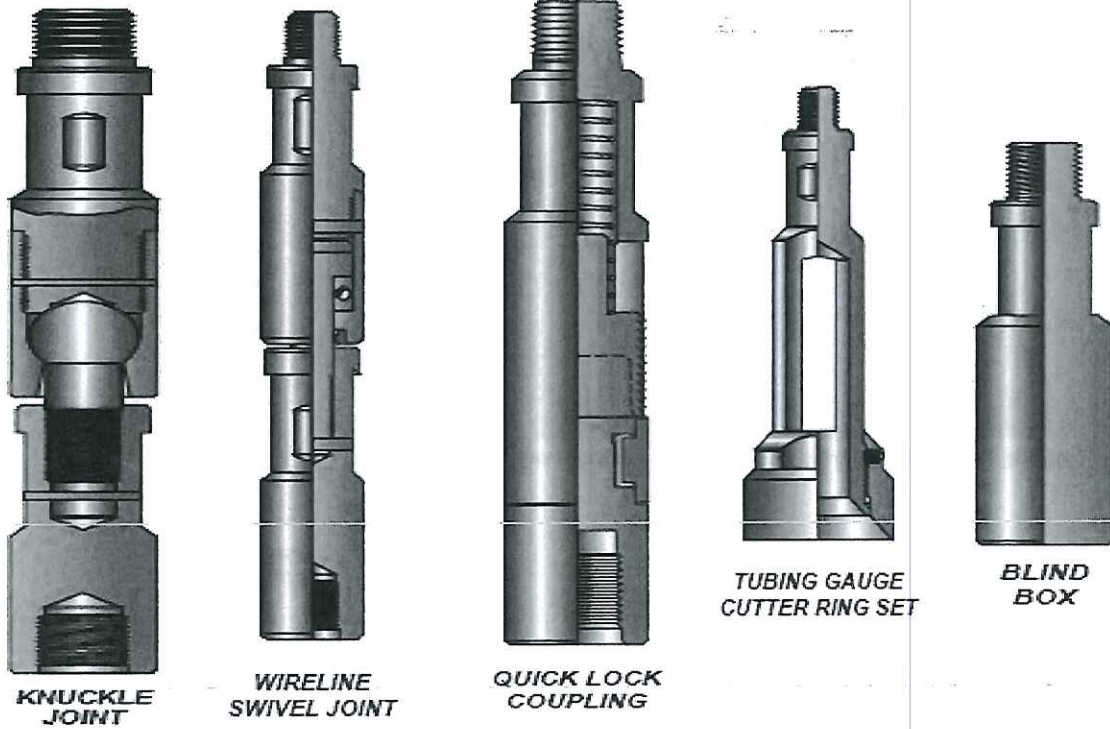

f) knuckle joints,

used to add flexibility to the toolstring and should be used in deviated
wells.

g) swivel joints,

The swivel joints is designed with a bearing to permit the easy
rotation of the toolstring, even under loads as tools move in/out
of the well. Swivel joint also essential to use between rope socket
and stem to prevent twisting of the line.

h) quick-lock coupling

A faster method connecting toolstring component is available using
the 'quick lock connection'. Advantages, speed of the toolstring
assembly.



F. What do we need to do if the tool is damage or lost in hole?

- 1/ Report wireline Supervisor / town.
- 2/ Prepare fishing plan and tool.
- 3/ Stop work.

G. What do we need to do if equipment failed to work?

- 1/ Report to town
- 2/ minor - troubleshoot
- 3/ major - Request mechanic from town / technician
- Request new equipment / Spare part

Alexson
ALEXSON AKIN
DIMENSION BID (M) SDN BHD
East Malaysia Operation



D. Rig up Wireline Surface Equipment

a. List out all surface equipment (Surface and Pressure Gauge)

1.	Power pack ✓
2.	Hydraulic mast ✓
3.	Reel skid unit (RSU) ✓
4.	Single well control panel (SWCP) ✓
5.	Genset ✓
6.	Air compressor ✓
7.	Huckel pump / Test pump ✓
8.	Recorder chart ✓
9.	Lubricator ✓
10.	Blow out Preventer (BOP) ✓
11.	Quick test Sub (QTS) ✓
12.	Ball valve ✓
13.	Crossover ✓

b. Describe how to connect lubricator section

Meysan
ALLEYSON AKIN
DIMENSION BID (M) SDN BHD
East Malaysia Operation

i) Horizontal

Lay down use trolley & stand ✓

ii) Vertical

Align the pin to box perfectly to avoid damaging the O-ring



Note: Provide drawing and parts description on separate paper/page

c. Sketch the equipment required while rigging up from x-mas tree until stuffing box

1mms

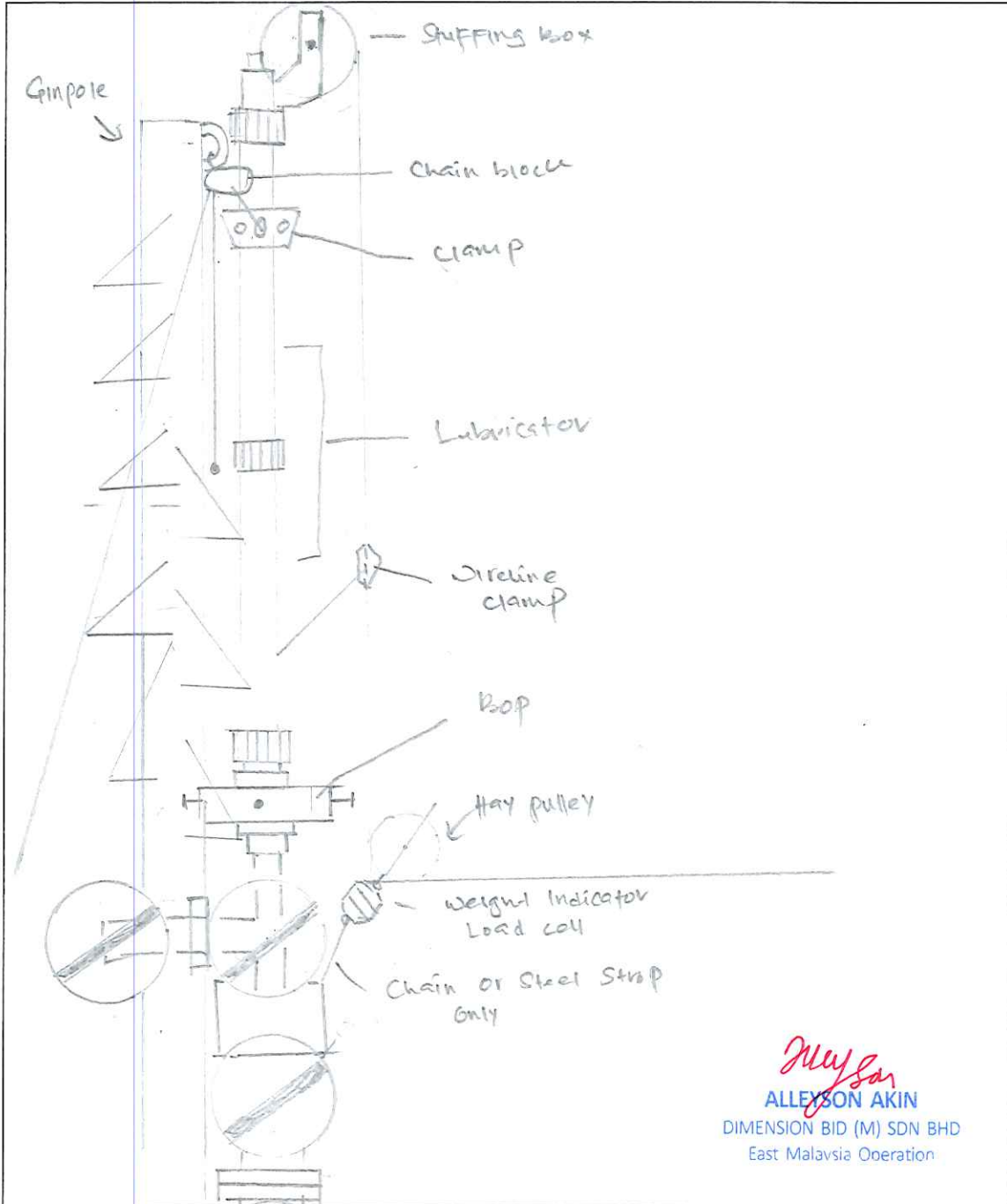

July 2011
ALLEYSON AKIN
DIMENSION BID (M) SDN BHD
East Malaysia Operation

Note: Provide drawing and parts description on separate paper/page

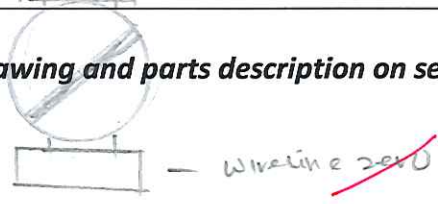



d. What should weight indicator attached with?

Key pulley / load cell ✓

e. What is the meaning of rigging up and rigging down?

Rig up: Assemble, connect PCE / Surface equipment

Rigging down: Disconnect / packing all PCE / Surface equipment ✓

f. What is power pack hose size used at Dimension Bid?

1" - supply $\frac{3}{4}$ 1 1/2" return ✓

g. What are the safety precautions required upon completed hook up hydraulic hose to RSU

- Install whip check at hose ✓
- Ensure no leak at hose ✓
- Double check connection hose ✓

h. List out the safety precaution while rigging up and rigging down

- USING full PPE ✓
- Read manual ✓
- Follow procedure ✓
- use correct lifting technique ✓

Note: Provide drawing and parts description on separate paper/page

Alleynson
ALLEYSON AKIN
DIMENSION BID (M) SDN BHD
East Malaysia Operation



RSu ✓
AN ✓
PP ✓
Huskel ✓
CP ✓
Specials device ✓