



SLICKLINE ASSISTANT WORKBOOK

IMPORTANT NOTE:

1. Your point of reference to complete this workbook may be obtained from the following
 - Training Manual and any other training materials provided together with this workbook
 - Your Trainer, Assessor (Slickline Operator), Verifier (FSM) or senior colleagues
 - SOP / Quality Procedures & Processors
2. The completion of this Workbook is a joint effort and responsibility between you and your assessor therefore you have the obligation to request from your assessor to be assessed upon your completion of each topic
3. The completion of this Workbook is part of the MANDATORY requirements which you must fulfill to qualify for a promotion
4. Your training program is mostly self-driven, including this Workbook. It requires individual initiatives, dedication and commitment to complete the process.

NAME	SELVESTER SILO ANAK KELLY	 GAZALI MEHRY Operation Manager Dimension Bid (M) Sdn Bhd Labuan Warehouse Slickline Services 28/2/25
DATE OF JOIN	02.09.2024	
CONTACT NO.	01117594205	
RECEIVED DATE	05.02.2025	
DATE COMPLETED	23.02.2025	



B. SURFACE EQUIPMENT

B.1. STUFFING BOX

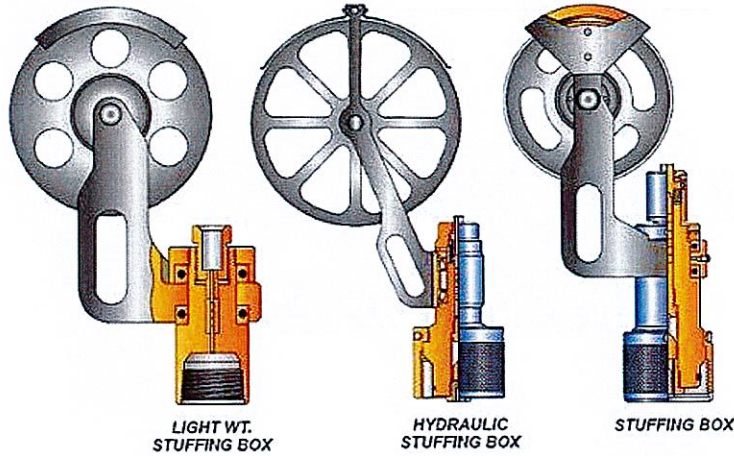

What is Stuffing Box

Stuffing box is a primary barrier that positioned at the uppermost point of the PCE string. ✓

What is the purpose of stuffing Box

To allows the wireline to enter the well under pressure and provide a seal should be wireline break and be blow out of packing. ✓

How to operate Stuffing Box

Stuffing box can be operated either manually or hydraulically which when hydraulic pressure is applied to area above piston, piston is forced downward against force of spring. ✓

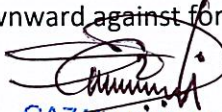
GAZALI MEHRY
 Operation Manager
 Dimension Bid (M) Sdn Bhd
 Labuan Warehouse
 Slickline Services

28/2/25



What is maintenance required for Stuffing Box

- Packings is not worn out ✓
- Use the correct sheave size for the line ✓
- Check upper and lower packing gland condition ✓
- Check BOP plunger for wear & freedom of vertical movement ✓
- Check sheave staff for freedom of swivel movement ✓
- Tighten sheave guard and adjust close to the sheave to ensure it will trap the line ✓

What is safety precaution required for Stuffing Box

Check for the packing whether worn out or in good condition and make sure using the correct size of sheave. ✓

What is potential hazard during handling Stuffing Box

- Drop object ✓
- Pinch point ✓
- Human error ✓
- Body position ✓

GAZALI MEHRY
Operation Manager
Dimension Bid (M) Sdn Bhd
Labuan Warehouse
Slickline Services

26/2/25



Draw & name each part of stuffing box

GAZALI MEHRY
Operation Manager
Dimension Bid (M) Sdn Bhd
Labuan Warehouse
Slickline Services



B.2. LUBRICATOR

What is Lubricator

Lubricator are a series of interconnected length of pipe and also known as risers.

What is the purpose of Lubricator

To provide a space for the tool to be contained in under pressure, when opening and closing the wellhead.

How to operate Lubricator

Connect lubricator section using chain block, wireline mast, crane or gin pole.

What is maintenance required for Lubricator

Check for general damage and corrosion, condition of the needle valves on the lower sections, visual inspection of the internal bore for corrosion and 'wire tracking' wear grooves. ✓

What is safety precaution required for Lubricator

Lubricator should be x-rayed
One of the lubricator must have a port to bleed of pressure ✓



GAZALI MEHRY
Operation Manager
Dimension Bid (M) Sdn Bhd
Labuan Warehouse
Slickline Services

28/10/18

What is potential hazard during handling Lubricator

Drop object
Pinch point
Back injury

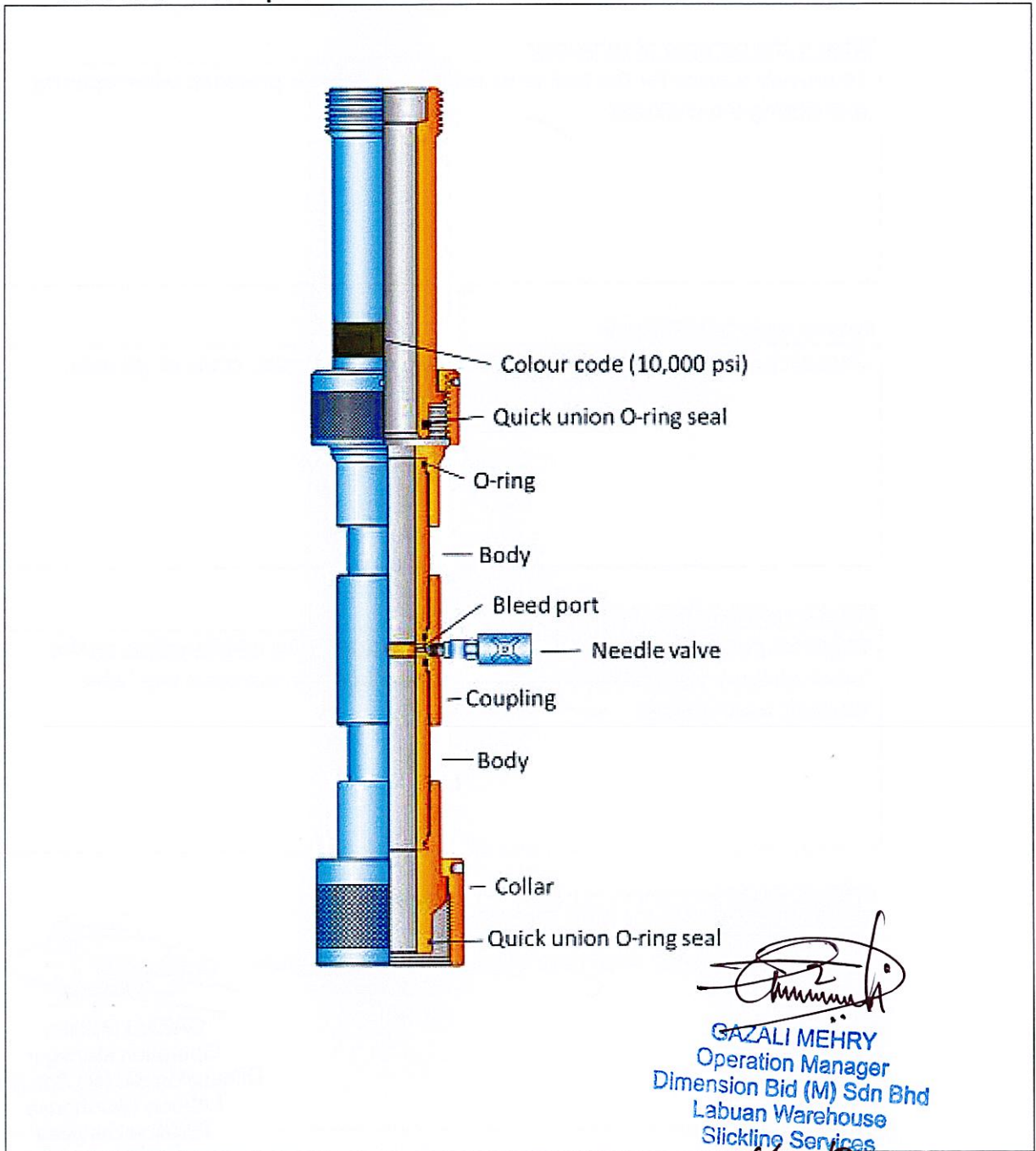
Draw & name each part of Lubricator



[Handwritten Signature]
GAZALI MEHRY
 Operation Manager
 Dimension Bid (M) Sdn Bhd
 Labuan Warehouse
 Slickline Services
 26/2/25



What is maintenance required for BOP

Must be service and need to be pressure tested ✓
Level 1 Service - To be carried out after every job ✓
Level 2 Service - To be carried out once a year ✓
Level 3 Service - To be carried out every 5 years ✓

What is safety precaution required for BOP

Ensure the rod has enlarged diameter below the ram to prevent it being blown out during testing. ✓

What is potential hazard during handling BOP

High pressure ✓
Back injury ✓
Human error ✓

GAZALI MEHRY
Operation Manager
Dimension Bid (M) Sdn Bhd
Labuan Warehouse
Slickline Services

26/2/25



B.3. BLOWOUT PREVENTER (BOP)

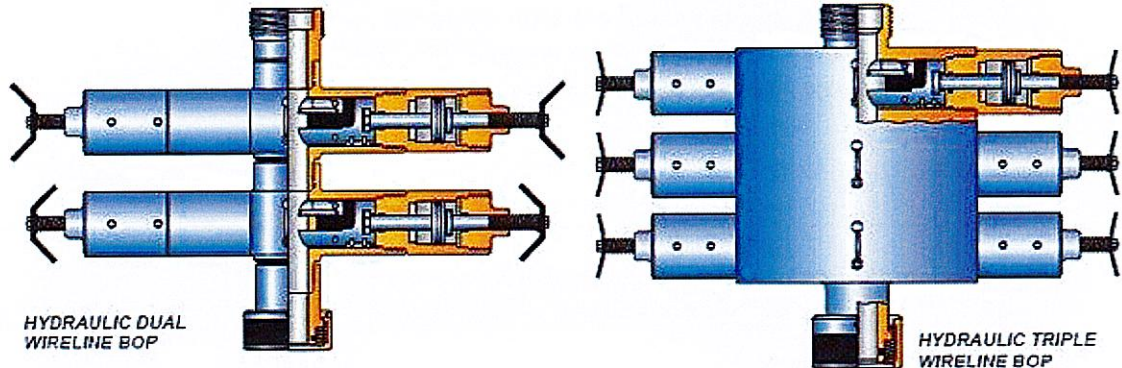

What is BOP

Blow out preventer or BOP is known as wireline valve which installed between the tree connection and lower lubricator section.

What is the purpose of BOP

- To enable the well pressure to be isolated without cutting the wire by closing the master valve
- Permit the assembly of the wireline cutter above the BOP rams and dropping it if the toolstring becomes stuck in the well
- Allow slickline work to be conducted while containing the well pressure on surface with wire in the wellbore

How to operate BOP

- Hydraulically
- Using RSU, control panel

[Signature]
 Operation Manager
 Dimension Bid (M) Sdn Bhd
 Labuan Warehouse
 Slickline Services

[Handwritten Signature]



Draw & name each part of BOP

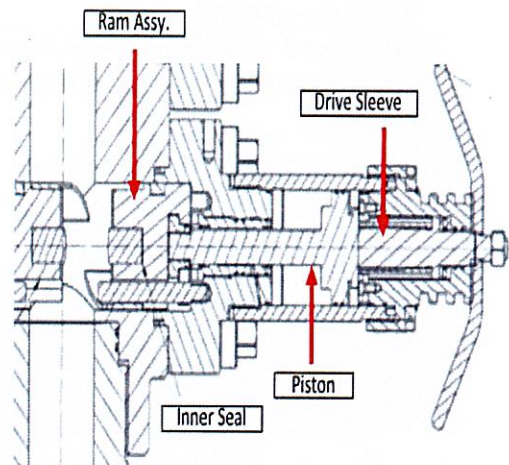
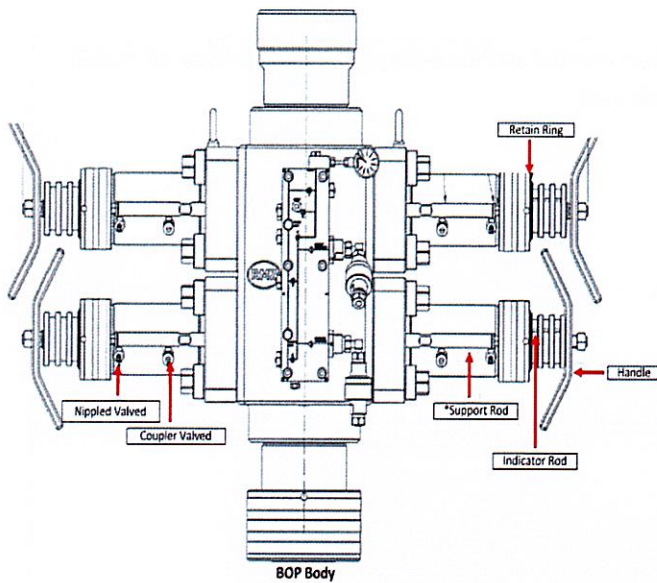

BOP Cylinder Body

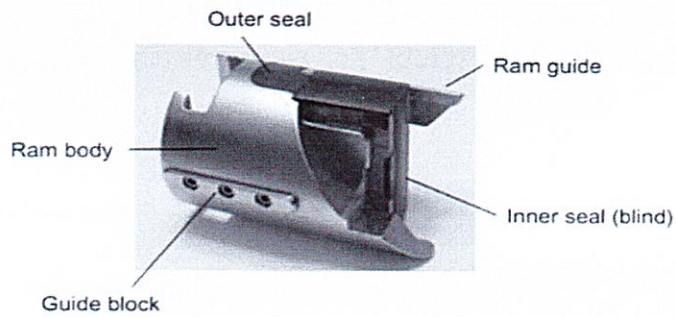
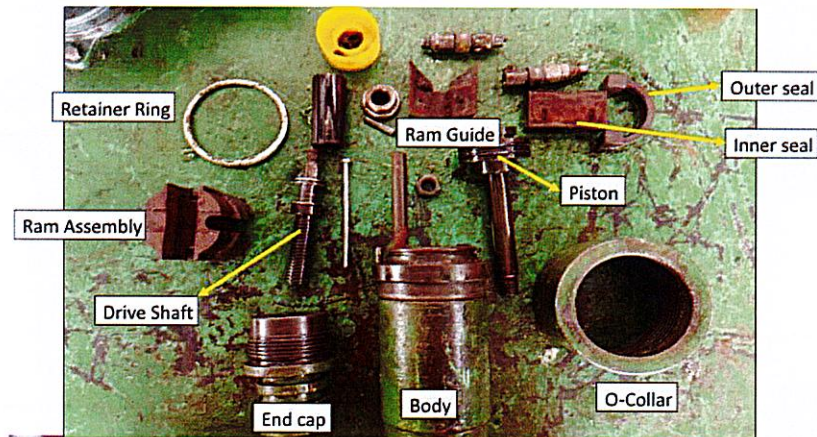

(Signature)
GAZALI MEHRY
 Operation Manager
 Dimension Bid (M) Sdn Bhd
 Labuan Warehouse
 Slickline Services
 26/2/25



B.4. X-MAS TREE

What is x-mas tree

Xmas tree is a series of valves installed on the wellhead to control the flow of fluids from the well. Located on top of wellhead.

What is the purpose of x-mas tree

Christmas trees are a vertical assembly of valves with gauges and chokes that allow for adjustments in flow control as well as injections to stimulate production

How to operate x-mas tree

The valves that comprise some of the decorations on the Christmas tree are opened when the oil or gas well is ready to produce and the processing and storage facilities are ready to receive.

What is maintenance required for x-mas tree

Inspect and replace any damaged component

Clean X-mas tree

Do Critical Device Function Test (CDFT) on X-mas tree (check all valves)

What is safety precaution required for x-mas tree

- Make a count during opening and closing the swab valve.
- Do not overtightened the valves during operation and closing
- Never use master valve to shut in the flowing well, except in an emergency situation. (use swab or wing valve)

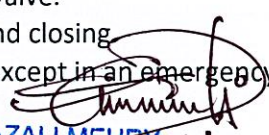
GAZALI MEHRY
Operation Manager
Dimension Bid (M) Sdn Bhd
Labuan Warehouse
Slickline Services

28/2/25



What is potential hazard during handling x-mas tree

- Pinch Point
- High Pressure
- Suspended Load
- Line of Fire

Draw & name each part of x-mas tree

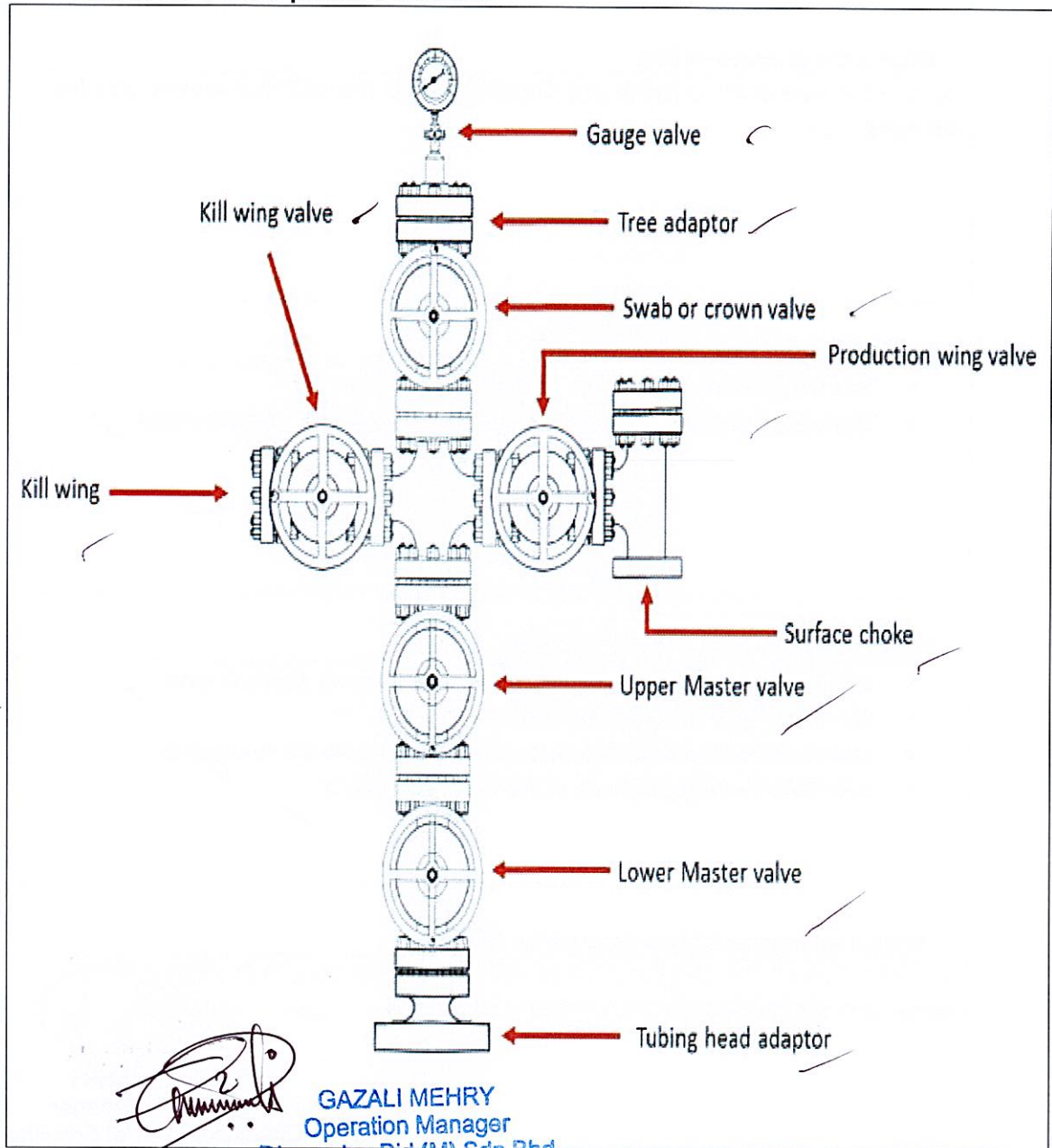

GAZALI MEHRY
Operation Manager
Dimension Bid (M) Sdn Bhd
Labuan Warehouse
Slickline Services

26/2/25

B.5. WIRELINE REEL SKID UNIT (RSU) / WINCH – SINGLE DRUM AND DOUBLE DRUM

What is RSU

RSU also known as wireline unit or winch ✓

What is the purpose of RSU

To turn the wire drum to lower and rise toolstring in the well that require wireline servicing ✓

How to operate RSU

- By using power pack and winch hydraulic system ✓
- Transmission of hydraulic hole via hole between power pack / RSU ✓

What is maintenance required for RSU

- Inspect hydraulic hoses, connections, and seals for leaks or wear. ✓
- Check the winch and wire drum for damage. ✓
- Ensure safety systems and emergency shutdowns are functional. ✓
- Lubricate moving parts and components regularly. ✓

What is safety precaution required for RSU

Wear full PPE and be careful with the wire / rotating drum winch when running because it might break and may cause injury

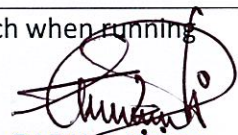
GAZALI MEHRY
Operation Manager
Dimension Bid (M) Sdn Bhd
Labuan Warehouse
Slickline Services

28/2/25



What is potential hazard during handling RSU

- Moving Parts ↗
- Heavy Equipment ↗
- Slips, Trips, and Falls ↗
- Personnel Injury ↗
- Pinch Point ↗

Draw & name each part of RSU

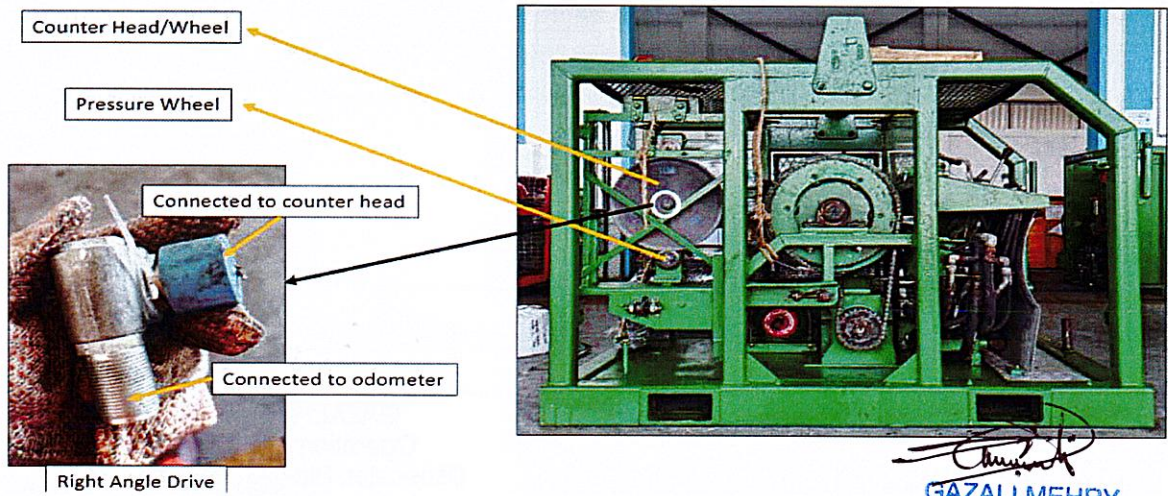
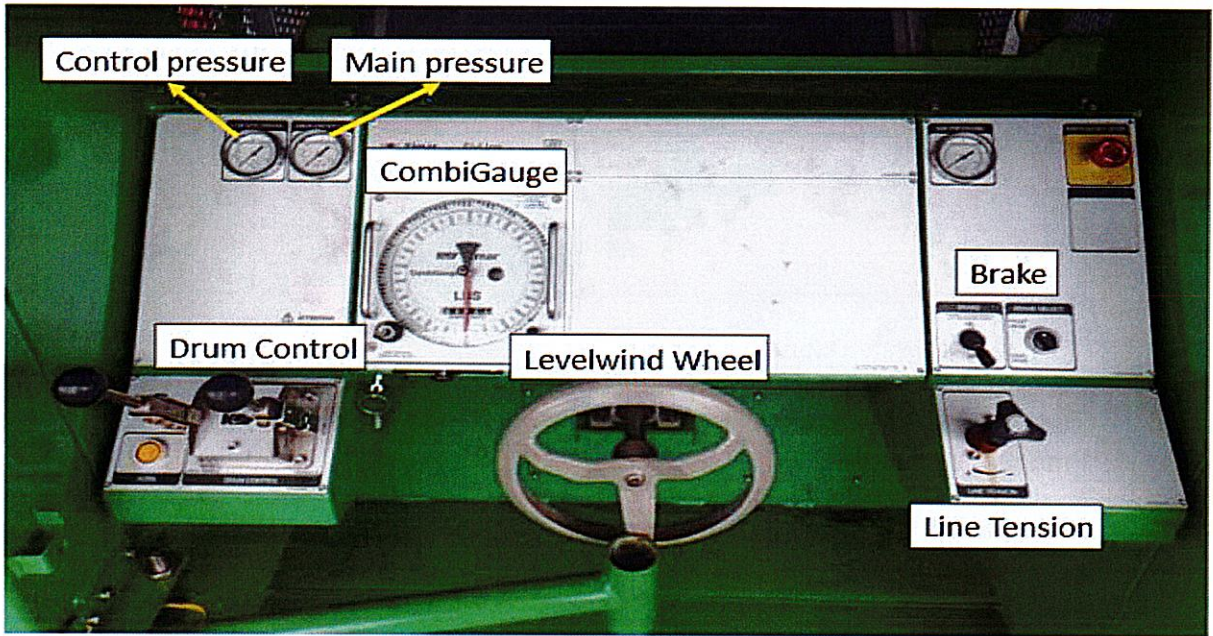

GAZALI MEHRY
GAZALI MEHRY
Operation Manager
Dimension Bid (M) Sdn Bhd
Labuan Warehouse
Slickline Services

5/10/2018



B.6. ODOMETER

What is Odometer

Odometer also known as Depth Counter / Depth Measuring device ✓

What is the purpose of Odometer

To indicate the depth of slickline toolstring hanging in a tubing string in feet or meters ✓

How to operate Odometer

Prior to operation, this device should be manually set to zero and start reading from tubing hanger. Connect hose to right angle drive and put odometer to RSU for monitoring puposes. ✓

What is maintenance required for Odometer

Maintenance for an odometer includes regular calibration to ensure accuracy, cleaning to remove dirt or moisture, inspecting for physical damage, and check if counter head is free to rotate. ✓

GAZALI MEHRY
Operation Manager
Dimension Bid (M) Sdn Bhd
Labuan Warehouse
Slickline Services



What is safety precaution required for Odometer

- Avoid physical impacts to prevent internal damage. ✓
- Handle the device carefully to avoid injury from moving parts. ✓
- Regularly check calibration for accurate readings. ✓
- Keep the odometer clean and free from dirt, moisture, or chemicals. ✓

What is potential hazard during handling Odometer

- Sharp Edges ✓
- Pinch Point ✓

Draw & name each part of Odometer

Set Knob: Use to reset measurement

Connected to counter head

Connected to odometer cable

Right Angle Drive

Available in feet-reading and meter-reading.

Connected to odometer

Connected to 1:2 right angle drive

Counter cable

(Handwritten signature)
GAZALI MEHRY
 Operation Manager
 Dimension Bid (M) Sdn Bhd
 Labuan Warehouse
 Slickline Services



B.7. WEIGHT INDICATOR (2000 LBS AND 4000 LBS)

What is Weight Indicator

Weight indicator is a device to measure weight of tools in tubing string. The device is connected to load cell using a rubber hose filled with hydraulic hose.

What is the purpose of Weight Indicator

To determine the total weight of tools hung in tubing string

How to operate Weight Indicator

The weight indicator (located at RSU) is connected to the load cell using a rubber hose filled with hydraulic oil. Load cell is attached to heavy-duty hose carries the pressure generated to the weight indicator gauge calibrated in lbs. It is using hydraulic system

What is maintenance required for Weight Indicator

It is necessary to completely flush and re-charge the unit at least once per month. Having recharged the unit, a specific gap should be set between load plate and load cell retaining ring.

- Check for leaks around the hose and priming check valve assembly.
- If additional "W-15" fluid is required, fill through the small port on the upper side of the gauge housing.

What is safety precaution required for Weight Indicator

Do not crash the hose
Secure gauge and fittings because the load cell is made of aluminum alloy and reasonably strong rough handling can damage it.

GAZALI MEHRY
 Operation Manager
 Dimension Bid (M) Sdn Bhd
 Labuan Warehouse
 Slickline Services

B.8. SPOOLING DEVICE

What is Spooling Device

Generally, one configured with removable drum that allow transport spools to be inserted, allowing the new string to be spooled into reel ✓

What is the purpose of Spooling Device

To hold the reel drum during spooling process
Control the tension of the line as it is spooled ✓

How to operate Spooling Device

Assemble the reel. The setup is almost the same with normal operation, which weight indicator and hay pulley are needed
Brake level will help to control the line tension ✓

What is maintenance required for Spooling Device

Brake maintenance
Always check the hydraulic system ✓

What is safety precaution required for Spooling Device

Make sure to check the glass in good condition before start the job
Bolts and nuts (shaft) are in good condition ✓

GAZALI MEHRY
Operation Manager
Dimension Bid (M) Sdn Bhd
Labuan Warehouse
Slickline Services

26/21/25



What is potential hazard during handling Spooling Device

- Pinch point ✓
- Rotating device ✓

Draw & name each part of Spooling Device

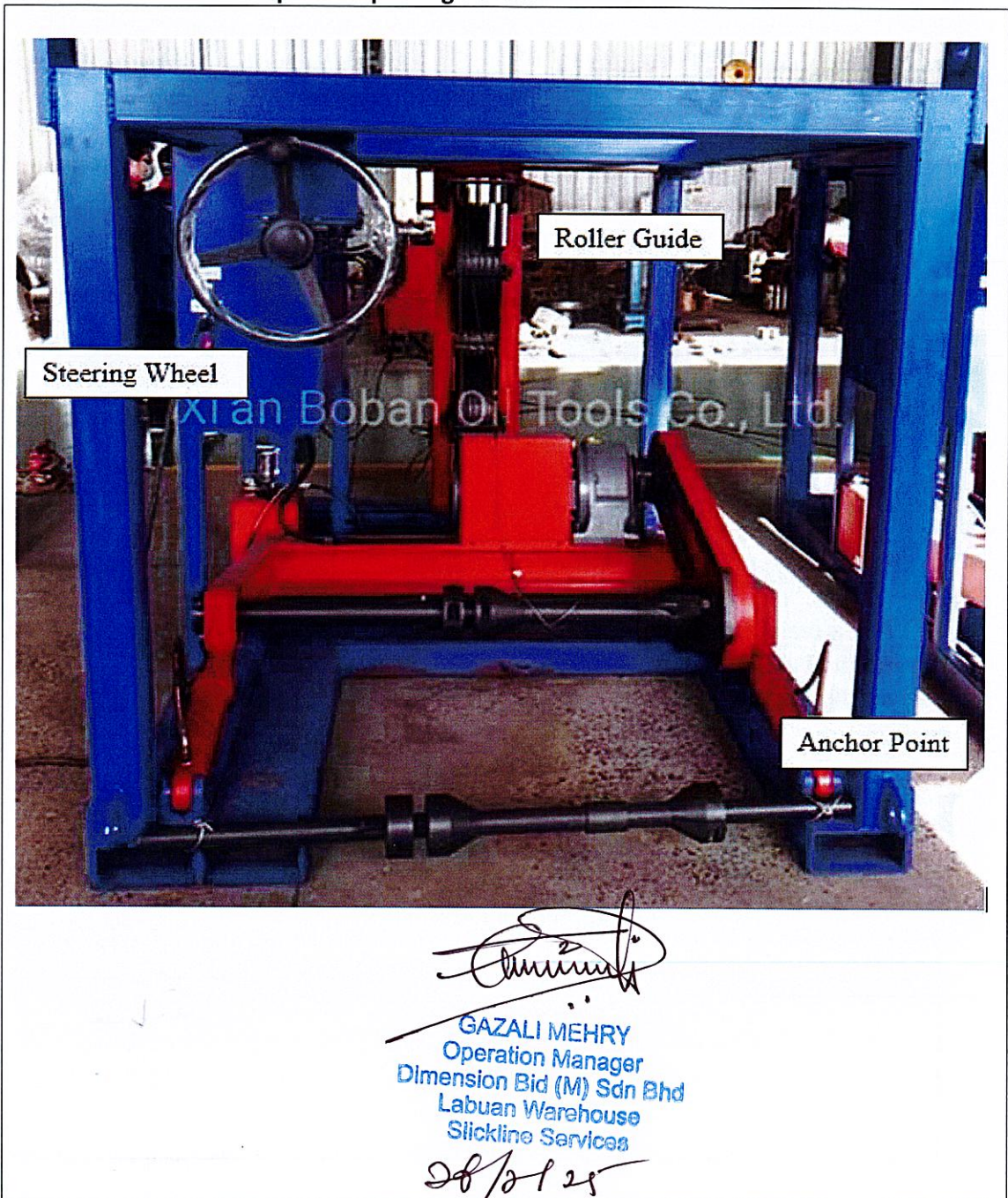



B.9. CONTROL PANEL

What is Control Panel

Control panel are used to operate a number of valves normally operated in slickline operations. ✓

What is the purpose of Control Panel

To operate BOP rams and provide a high pressure oil output from a low pressure air or gas input. ✓

How to operate Control Panel

Connect the control line to the equipment
Open air supply, use regulator to control pump out pressurized the line. ✓

What is maintenance required for Control Panel

Check the fluid level of hydraulic oil
Check the hydraulic hoses for any sign of leakage or damage. ✓

What is safety precaution required for Control Panel

Do not tighten or loose the connection when under pressure
Beware of trapped pressure by bleed off fully before open connection ✓



What is potential hazard during handling Control Panel

- Falls, Slips and Trips from hose and fluid leaks. ✓
- Hose burst due to working with high pressure ✓
- Personnel injury due to lose connections ✓

Draw & name each part of Control Panel

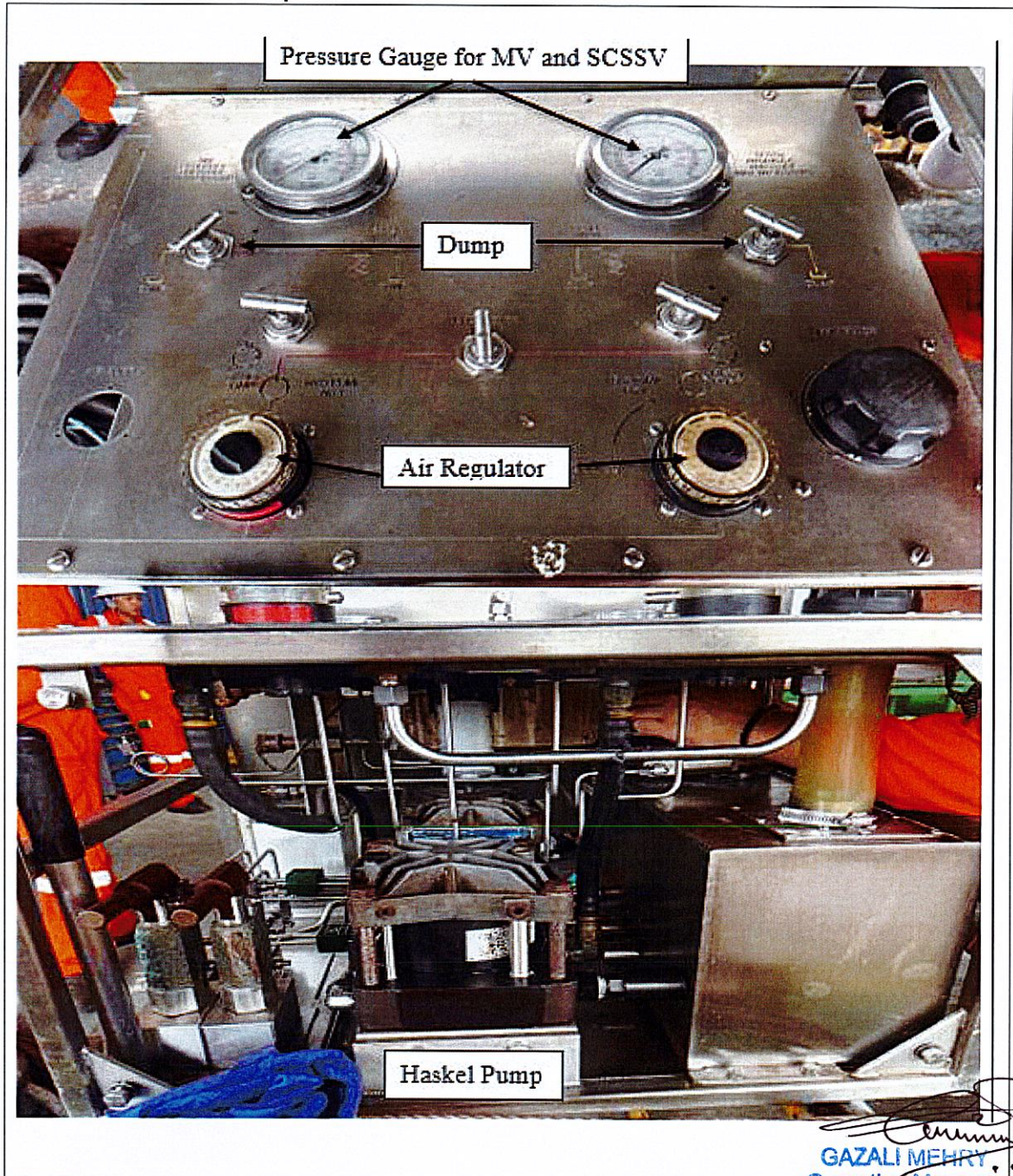

[Signature]
GAZALI MEHRY
Operation Manager

Dimension Bid (M) Sdn Bhd
Labuan Warehouse
Slickline Services

28/2/25



B.10. HUSKEL DRUM

What is Huskel Drum

Is an air driver pump ✓

What is the purpose of Huskel Drum

To drive the hydraulic or water in control panel or test pump ✓

How to operate Huskel Drum

Operate from the knob or regulator of the panel ✓

What is maintenance required for Huskel Drum

Check the condition of the O-ring ✓
Service huskel pump ✓
Hydraulic check valve and liquid seal repair ✓

What is safety precaution required for Huskel Drum

Check O-ring condition ✓
Make sure connection tubing is in good condition ✓

GAZALI M. ...
Operation Manager
Dimension Bid (M) S.
Labuan Warehouse
Slickline Services



What is potential hazard during handling Huskel Drum

Pinch point ✓
Tubing burst

Draw & name each part of Huskel Drum

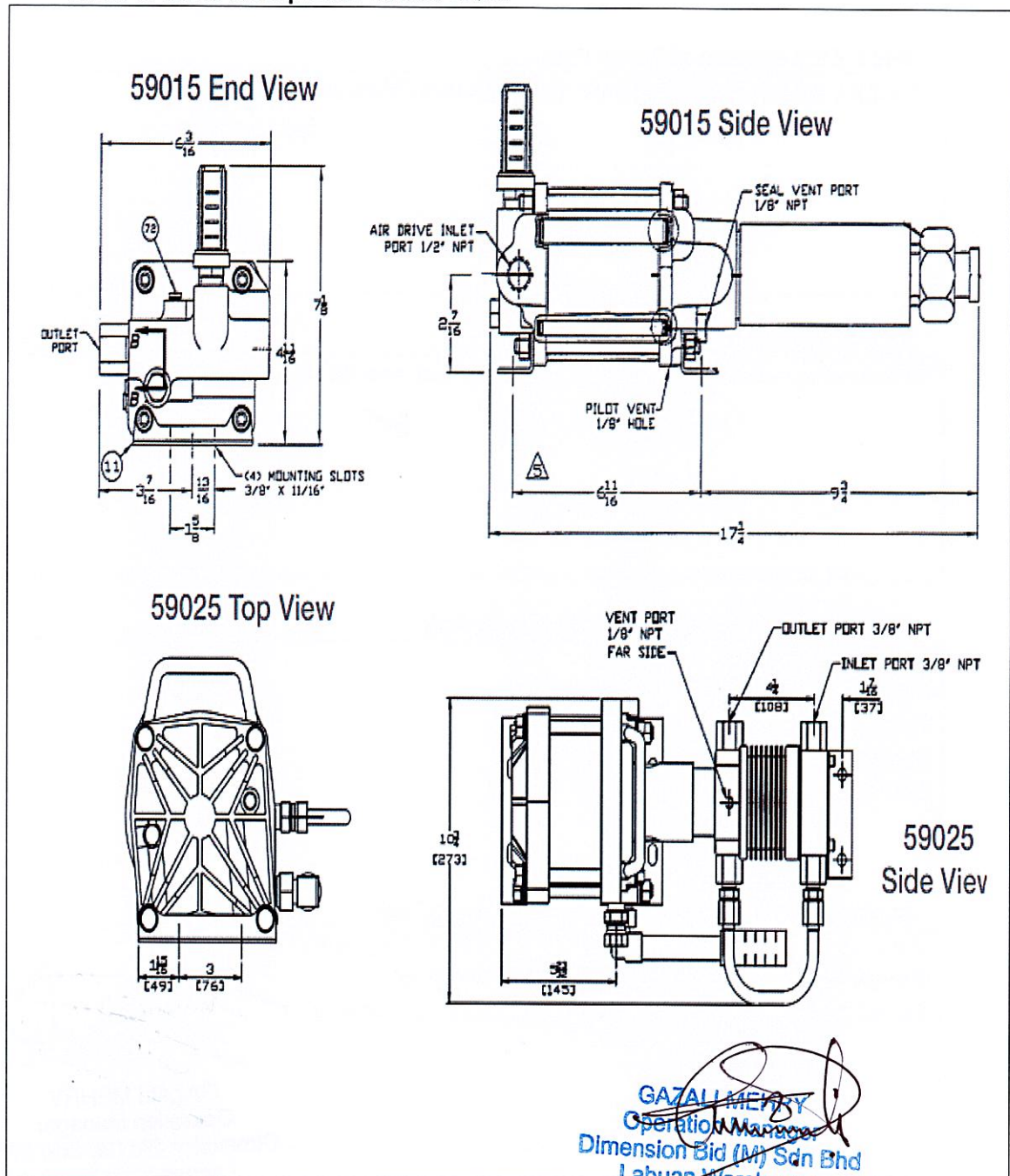

26/2/25

B.11. POWER PACK (ELECTRICAL & DIESEL)

What is Power Pack

Power pack is a single piece configuration, skid mounted with integral crash frame, constructed in carbon steel with single point lifting ✓

What is the purpose of Power Pack

To supply driving hydraulic power to equipment (Mast and RSU) ✓

How to operate Power Pack

By operating several valves, adjust speed, power and rotation of drum ✓

What is maintenance required for Power Pack

- Check oil level ✓
- Check water level ✓
- Check diesel level ✓
- Check condition of belting ✓
- Check any leaking ✓

What is safety precaution required for Power Pack

- Wear appropriate PPE when changing hydraulic oil/ engine oil ✓
- Beware of rotating fan when engine is running ✓
- Do not open radiator cap while power pack is still running ✓

GAZALI MEHRU
Operation Manager
Dimension Bid (M) Sdn Bhd
Labuan Warehouse
Slickline Services

28/2/25



What is potential hazard during handling Power Pack

- Hose burst ✓
- Hand injury ✓
- Rotating fan ✓

Draw & name each part of Power Pack

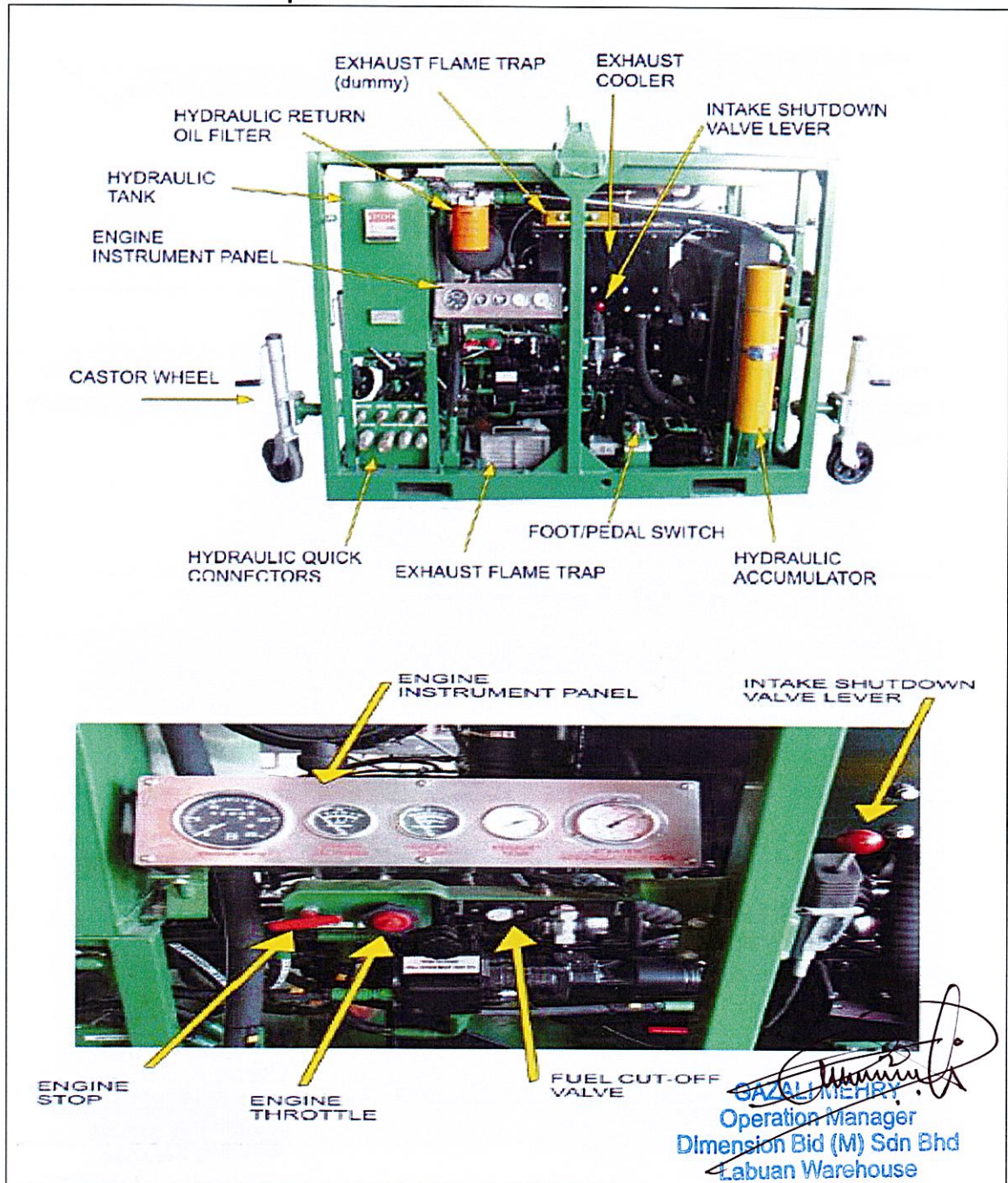

26/10/18

B.12. AIR COMPRESSOR

What is Air Compressor

Air compressor is an open loop hydraulic system unit which is used to supply compressed air to Control Panels when there is no supply on site ✓

What is the purpose of Air Compressor

To supply compressed air for control panel, test pump and air stater engine ✓

How to operate Air Compressor

Starting procedure is almost the same with power pack. The air compressor usually use spring starter. To crank the starter, rotate the shaft clockwise until indicator turn red. Replace spring to start the engine ✓

What is maintenance required for Air Compressor

Change filters ✓
Change oil compressor ✓
Check fan belting condition ✓

What is safety precaution required for Air Compressor

Make sure all hoses connection no leaking ✓
Make sure fan is covered ✓

GAZALI MEHRY
Operation Manager
Dimension Bid (M) Sdn Bhd
Labuan Warehouse
Stickline Services

26/2/25



What is potential hazard during handling Air Compressor

- Hose burst ✓
- Pinch point ✓
- Hot surface ✓

Draw & name each part of Air Compressor

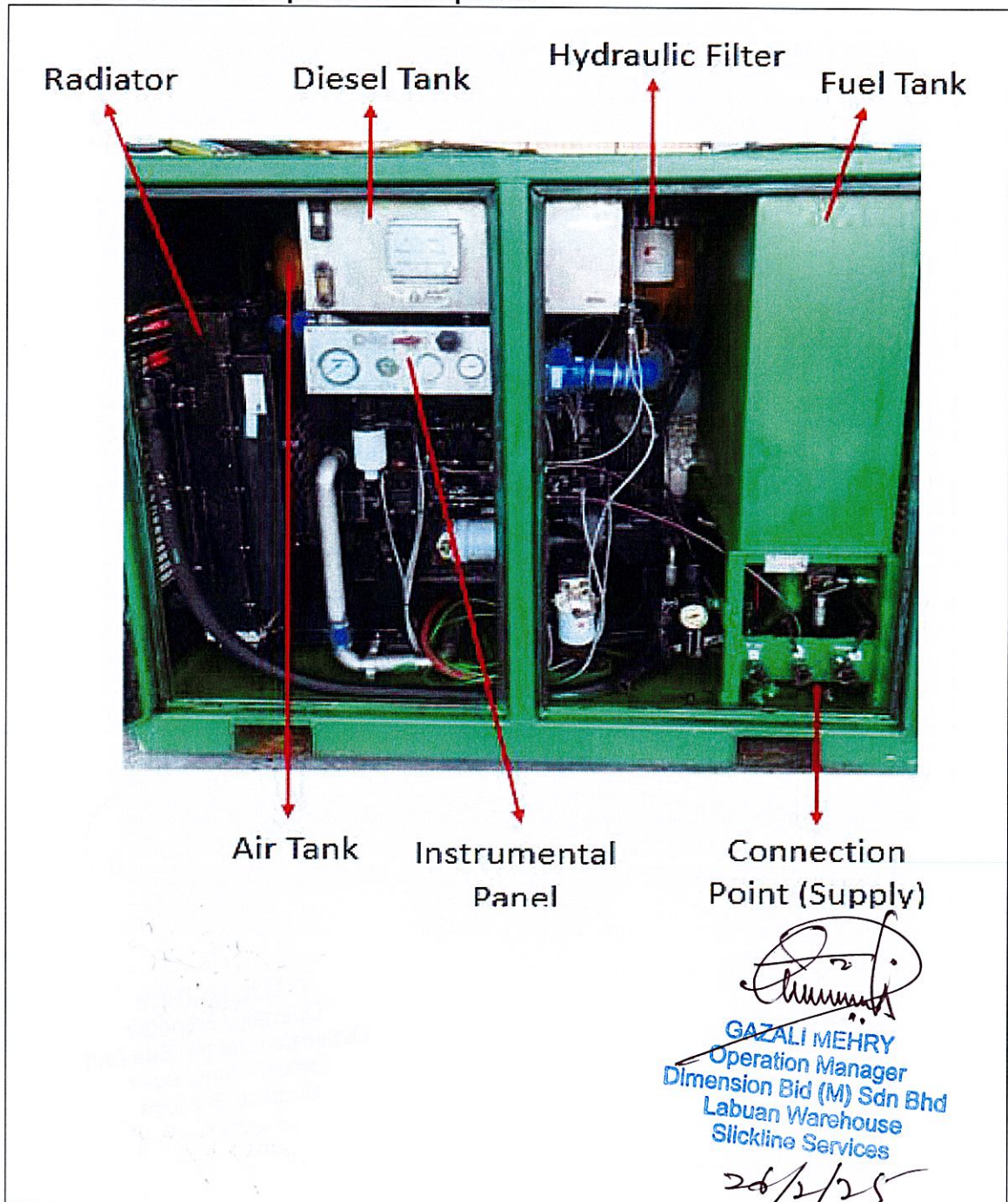

B.13. DRUM

What is the purpose of Drum

To spool the wireline wire ✓

Draw the right and wrong wire arrangement from drum to hay pulley

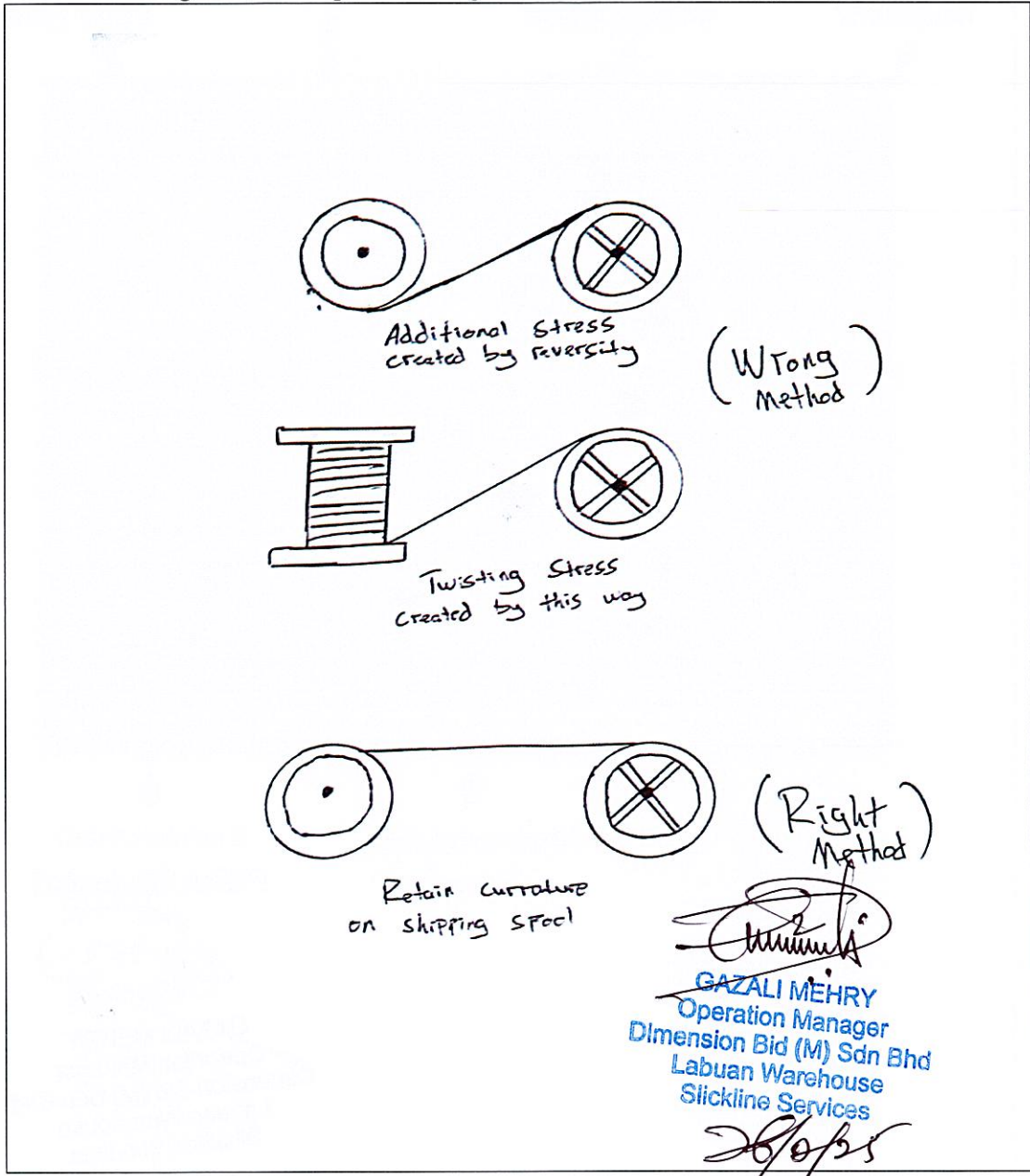



What is maintenance required for Drum

Make sure to service and always check the drum bearing, change if there have any broken or damage ✓

What is safety precaution required for Drum

Use tag line or push pull stick ✓
Make sure using the safety glasses and appropriate PPE ✓

GAZALI MEHRY
Operation Manager
Dimension Bid (M) Sdn Bhd
Labuan Warehouse
Slickline Services

26/2/25



What is potential hazard during handling Drum

- Rotating device ✓
- Pinch point ✓
- Back injury ✓

Please draw/sketch the toolstring configuration for:

- 1) Drift run/tubing clearance check ✓
- 2) Sinker bar run ✓
- 3) Set and retrieve plug ✓
- 4) Set and retrieve insert valve ✓

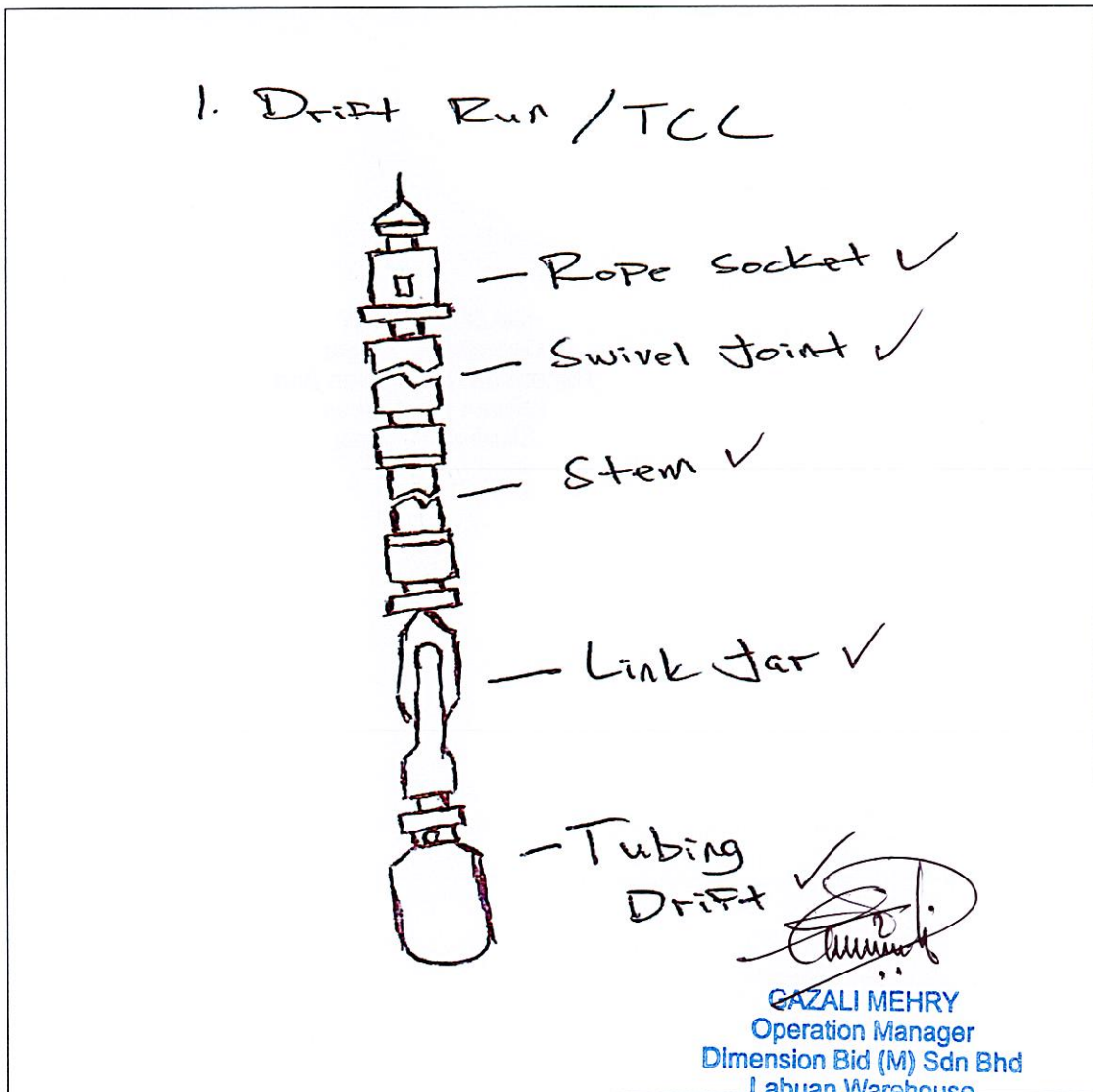

20/2/25



2. Sinker Bar Run

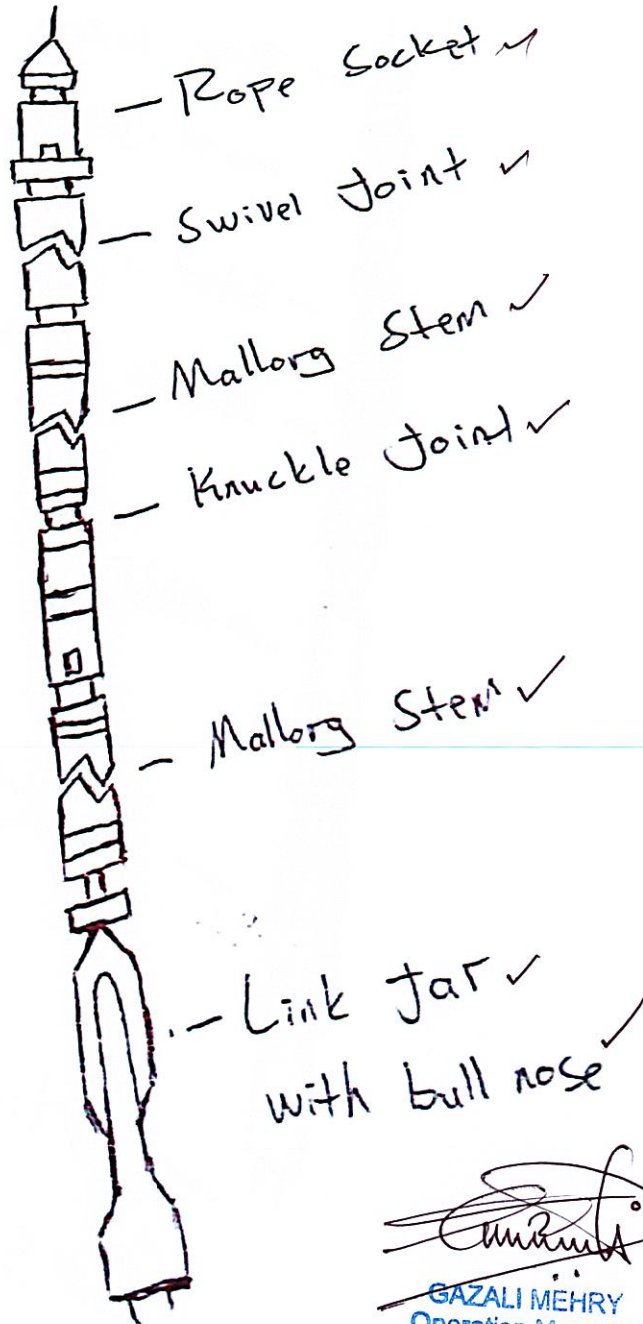

GAZALI MEHRY
Operation Manager
Dimension Bid (M) Sdn Bhd
Labuan Warehouse
Slickline Services

28/2/25



3. Set / Retrieve Plug

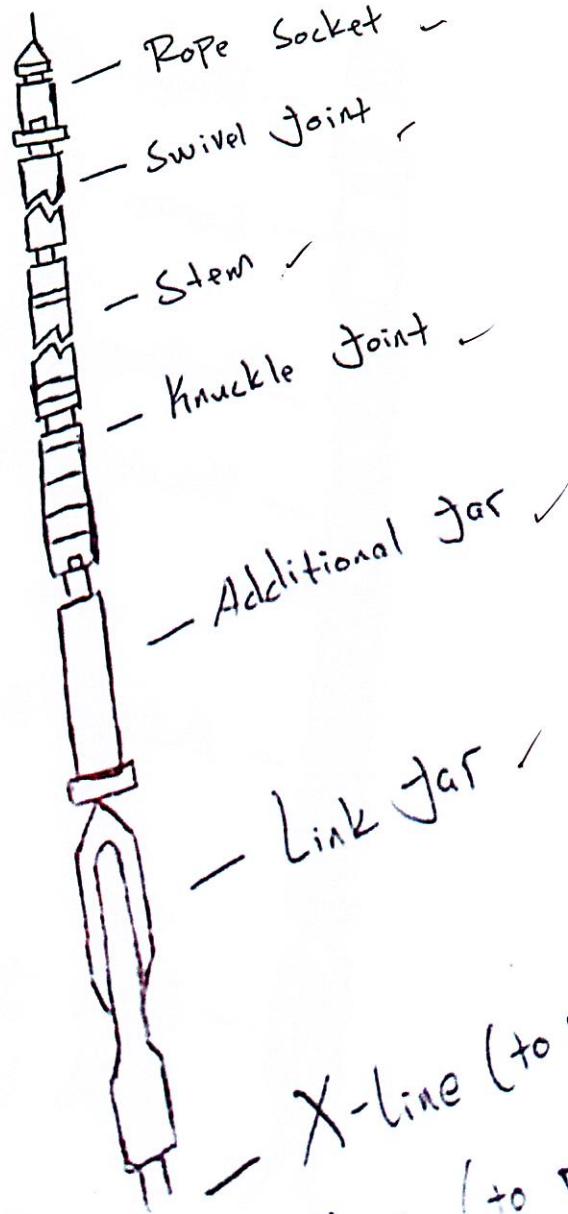

GAZALI MEHRY
Operation Manager
Dimension Bid (M) Sdn Bhd
Labuan Warehouse
Slickline Services

[Handwritten signature]
28/1/2018



4. Set / Retrieve Insert Valve



- Rope Socket

- Swivel Joint

- Stem

- Link Jar

- X-Line + Prong
(to set)

- GSL + Prong
(to retrieve)

GAZALI MEHRY
Operation Manager
Dimension Bid (M) Sdn Bhd
Labuan Warehouse
Slickline Services

